

FOR USE WITH 1E AD&D FOR UP TO 6 CHARACTERS LEVELS 8-10

The Demon's Eye



This six part adventure pits the player characters against sinister demons, foul undead, and multiple deadly puzzles and traps, all with the goal of escaping the dungeon alive with treasure intact. A collaborative effort, The Demon's Eye was created specifically for the CAFCON 2019 gaming convention located in Morganton, North Carolina!

Wizard of The Ozarks
CAFCON 2019

The Demon's Eye

A collaborative dungeon module by the ingenious minds of Anthony Meder, Brandon Gallant, Chris Larr, Chuck Green, & Daniel Etheridge. All friends and members of the one and only **1st Edition Advanced Dungeons & Dragons Uncensored Facebook Page**.

This module was designed exclusively for play by VIPs of the 2019 CAFCON Gaming Convention in Morganton, North Carolina April 6-7, 2019, written by the above mentioned, and edited by the illustrious up-and-coming game publisher **Wizard of the Ozarks**. If you enjoy this adventure, check out some of their other titles as well! You can find more information at www.cafconrpg.net and www.facebook.com/ozarkwizard respectively.

The Demon's Eye module is designed for the 1st Edition AD&D rules system or similar "old school" RPG game systems.

TABLE OF CONTENTS

| | | |
|--------------------|---|---------|
| Story lead in | - | Page 2 |
| Main Chamber | - | Page 3 |
| 1 Dragon Skull | - | Page 5 |
| 2 Medusa Garden | - | Page 8 |
| 3 Mirror Quandary | - | Page 12 |
| 4 Fun House | - | Page 14 |
| 5 Pumpkin Patch | - | Page 22 |
| 6 Blood Stone | - | Page 24 |
| Aftermath | - | Page 27 |
| Magic Items | - | Page 28 |
| Bestiary | - | Page 29 |
| Pre-Gen Characters | - | Page 32 |

The beautiful cover art is drawn and colored by the talented Joseph Garcia.

You can find more of his work at

www.facebook.com/artofjosephgarcia



Story lead in –

On a previous adventure, the party discovered an old weathered scroll which described an epic dungeon filled with mysterious wonders, powerful artifacts, and loads of treasure. It gave a brief description of its whereabouts and something about an entombed sorcerer. To be exact, it spoke of an ancient necromancer called Vladimir the Dark, a wicked man who did vile unspeakable things...unnatural. After a small but vivid conversation on the matter, it was decided that this dungeon would be explored and relieved of its valuable contents. Of the necromancer, if need be, that would be dealt with if the complication presented itself. Supplies are filled, armor is repaired, and weapons are double-checked. It's time to adventure!

This module is recommended for six characters of level 8-10. Because of the presence of a necromancer, it is recommended that the party includes at least one or even two clerics with the ability to turn or otherwise battle the undead.

Included in this module are six pre-generated characters, two of which are clerics. A paladin might also suffice, but this is up to the players/DM.

Upon finding the location of the dungeon, known by the locals as the "Onyx Slab", the adventurers discover a rectangular slab of black granite roughly 5' x 7' sunk down into the side of a hillside of light grey sandstone. Carved upon the surface of the granite slab are strange markings written in the language of ancient elves. Anyone who is semi-fluent in Elven can roughly translate the markings written a thousand years ago saying,

"WITHIN THIS TOMB ARE THE REMAINS OF A VILE HUMAN WIZARD KNOWN AS VLADIMIR. TREAD WITH CARE."

With a combined d20 roll of 62, the heavy slab can be opened, releasing 1000-year-old poisoned air. Anyone within 6' must save versus poison or take 1-4 damage.

"The party successfully cracks open the seal to the mysterious dungeon! You watch cautiously as air screams from the seam, air that has been trapped for a thousand years!!! Once the high-pitched whistle recedes, you discover dark granite steps leading down deeper into the earth."



These steps carry the party down for roughly 200 feet, through an archway and into the main chamber.

The Main Chamber –

Walking through the archway, the party finds themselves in a massive six-sided room dominated by a gigantic statue in the likeness of a horned demon. Upon the chest of the statue, a skeleton is crucified, giant iron nails driven through its wrists and ankles. Hanging from its corpse are the remnants of tattered robes. A strange bit of detail, two small horns poke from the top of its skull. Upon closer inspection of the statue, of its two eyes represented by large red gemstone, one of them is missing! Centered on each of the six walls are black granite doors. Each door bears a number 1-6.

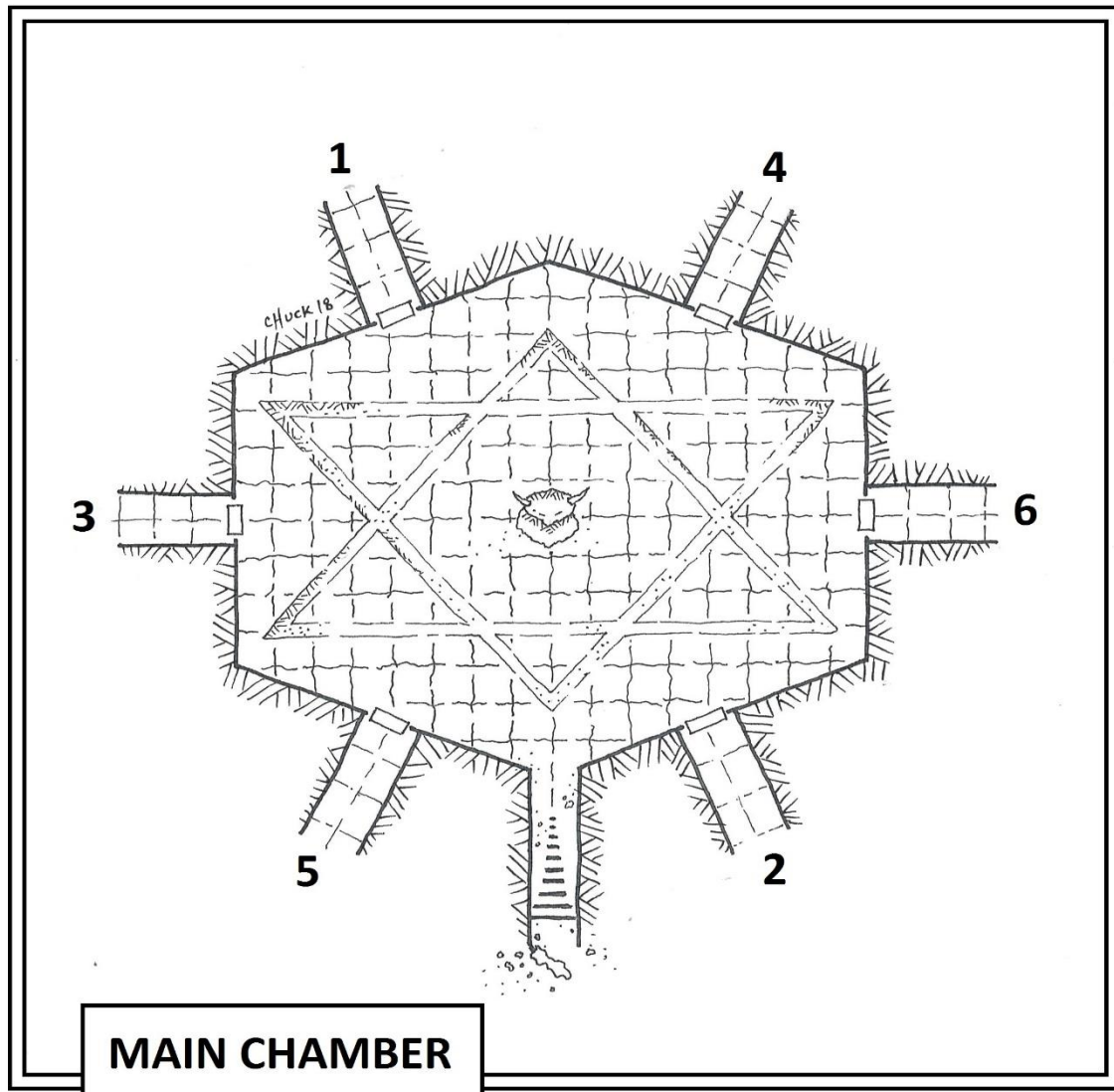

As the party approaches the skeleton, its eye sockets glow with an eerie red light. Its hands and feet are nailed to the demon statue, but its mouth opens and speaks...

"Greetings young mortals! I smell the sweet blood inside your veins! I am Vladimir the Dark, Master of Death, victim of the gods, FALSELY IMPRISONED!!! Free me and I shall grant you your greatest wish!!!"
After a short pause, he continues

"Somewhere in this dungeon is the demon's missing eye. Find it and replace it and you shall set me free!
At the end of each section of this dungeon is an iron handle. Pull this handle down and it shall open a door here in this chamber, unlocking another section, but MAKE HASTE!! The clock is ticking!"

Suddenly, the door marked with a 1 opens with a grind revealing a dark corridor beyond.

"Make HAAAAAAASTE!!" hisses the skeleton, just before the light from its eyes wink out and its head slumps to its chest.

DMs Note: At this point, roll a d6 to determine which dungeon section contains the statue's missing eye. If a 1 is rolled, reroll for a different result or choose a section yourself. At the CAFCON convention, the allotted time for this module was 4 hours. If similar time constraints are applied, make adjustments as needed.

Besides the stairs leading back to the surface, statue, the skeleton, and the six different doors, there is nothing else of interest in the main chamber.

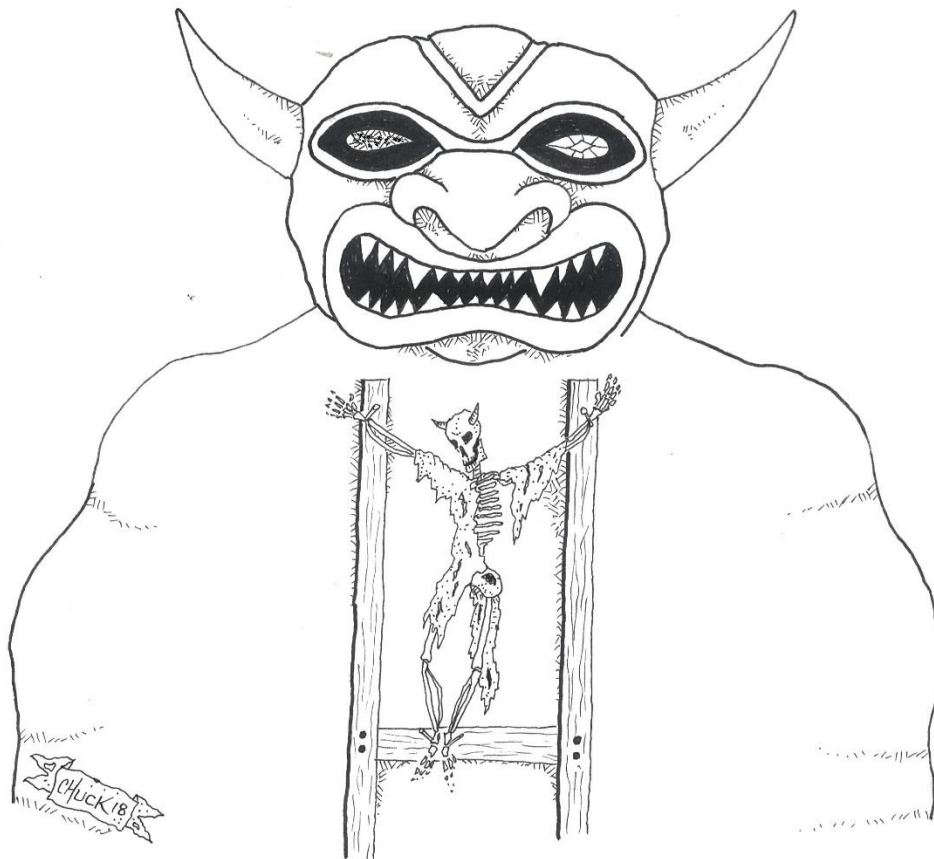

Early concept art
for the module
cover

Dragon Skull –

Written by Chuck Green

1- THE GREAT PIT

Once the animated skeleton finishes his speech and returns to lifeless bone, the stone door marked with a 1 grinds open, revealing a wide corridor leading into a dark tunnel. As you venture in, you find a hall that is only 25' long ending abruptly at a wide deep chasm. Looking down you see that some light illuminates the bottom of the pit, some 250' down or so. On either side of the end of the hall there are stone reliefs in the shape of a grinning gargoyle head. Both have long horns and small beady eyes.

DMs Note: Each of the gargoyle heads will hold up to 300 pounds if a rope is secured to them.

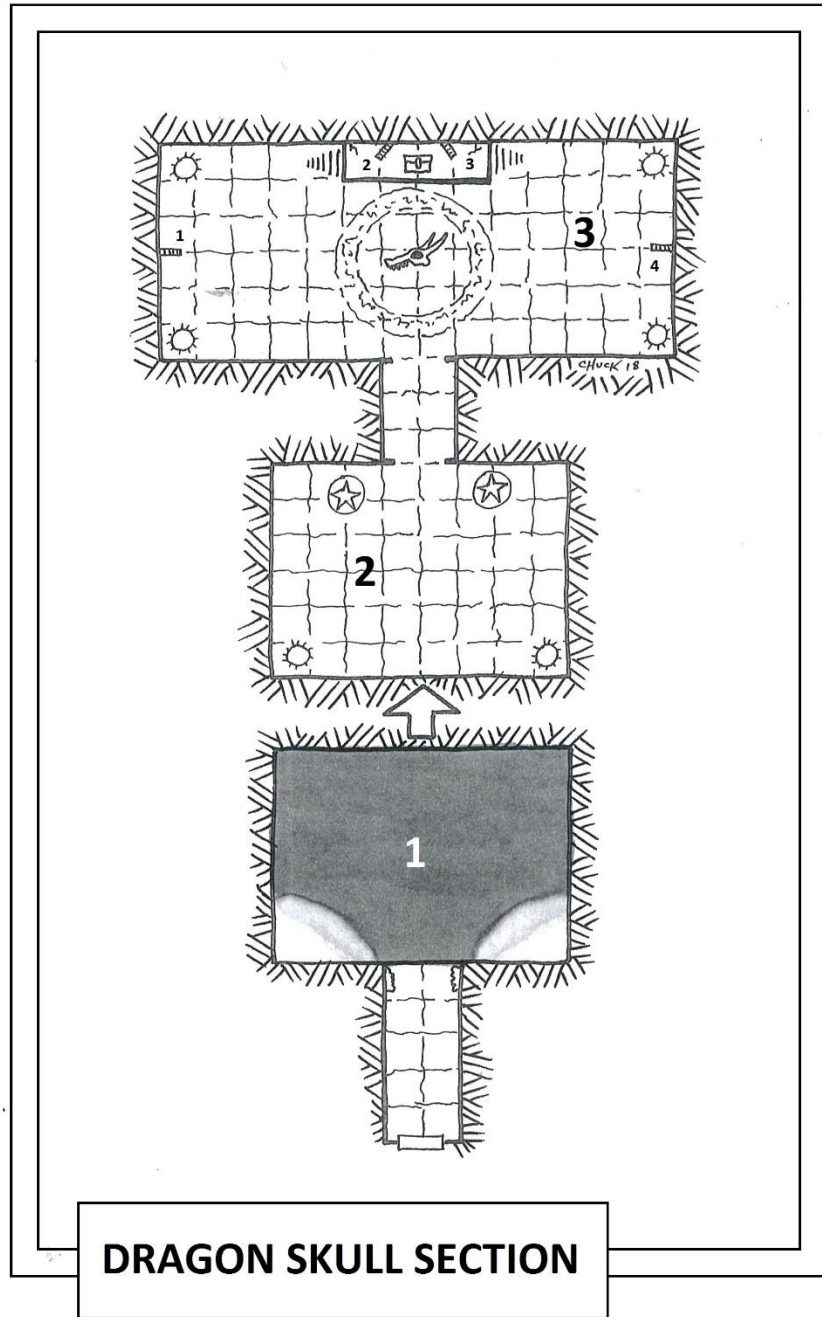

2 – CHAMBER OF ANGELS

Making it to the floor of the chasm, you find yourselves in a 30' x 40' room of dark grey smooth polished stone. The two nearest corners contain large braziers with coal burning brightly while the other side of the room holds a large archway. Flanking the archway are two tall stone statues, some 6 ½ feet tall, in the likeness of serene winged angels. Their hands cover their eyes as if they are weeping for the fate of the necromancer above.

DMs Note: For every turn that the PCs are in this room/are visible to the angels, each player must make a save versus breath weapon. Any character who fails this save has blinked their eyes or looked away from the statues and has allowed them to move closer. The angels' movement rate is 25' per round and they will race to the nearest target that has looked away or blinked. Once an angel is within 10' of their target, their appearance becomes more feral and they will appear to have gnashing fangs and razor-sharp claws!

(2) Weeping Angels: MV 25, AC -2, HD 9, HP 54,61, #ATK 2, DMG 1-4/1-4, SA quantum-port person, MR 55%



Quantum-port person: If a weeping angel makes a successful attack on its target, the angel quantum-ports its prey. Normally, this would immediately teleport the target, completely naked, 1d20+99 years into the past, in a random location 1d20+99 miles away, and gain that angel hit points equal to the total number of years its prey was teleported divided by 2. For this module's purposes, instead, the effect of quantum-port will immediately teleport the target back to the main chamber, all of their possessions intact, and the angel gains 2d10 hit points in health. Once quantum-ported, that particular player character gains a +2 bonus to their saving throws versus any and all weeping angels in the future.

3 – ARCANE SANCTUARY

Entering the large archway, a short corridor brings you to another archway, and a large great room some 70' x 30' in size with a vast ceiling that is more than 25' high. The four corners all have coal burning braziers. The far wall contains a raised dais accessible by two different staircases, that display two long iron levers, and a large iron chest. Centered in the middle of the room, on the floor, is a massive circular arcane etching, of which a large gnarled dragon skull sits. The wall to the far left has another iron lever, while the wall to the far right also has an iron lever. All four walls of this room are covered in wall painting depicting various acts of necromancy, creatures rising from their graves, hordes of zombies plowing into an army of armored soldiers, even an undead troll devouring a group of halflings.

DMs Note: Though there are no traps anywhere in this room, each iron lever has a different function. Each lever is marked with a number on the corresponding map.

Lever 1 – Pulling this lever down causes the dragon skull in the center of the room to quickly transform into a Bone Dragon amidst a billowy cloud of green and blue eldritch light! Pulling the lever back up has no effect.

Lever 2 – Pulling this lever down causes a random door to grind open in the Main Chamber. Pulling this lever back up causes the same door to grind close again.

Lever 3 - Pulling this lever down causes the dragon skull in the center of the room to quickly transform into a Bone Dragon amidst a fiery cloud of red and orange eldritch light! Pulling the lever back up has no effect.

Lever 4 – Pulling this lever down causes the iron chest on the dais to creak open, revealing its contents. Pulling the lever back up has no effect.

Green/Blue Bone Dragon: MV 12, AC 2, HD 8, HP 61, #ATK 3, DMG 1-6/1-6/3-24, SA breath weapon bolt of lightning 10' long, SZ L (40' long)

Red/Orange Bone Dragon: MV 9, AC -1, HD 10, HP 78, #ATK 3, DMG 1-8/1-8/3-30, SA breath weapon cone of fire 9' long 3' at base, SZ L (45' long)

The iron chest contains:

200 copper coins

275 silver coins

304 gold coins

75 electrum pieces

50 platinum pieces

2 Heal Potions

Potion of Levitation

Sylamore's Gentle Caress – a single thin green malachite glove, grants the wearer +2 against petrification, attracts a swarm of gnats



Medusa Garden – Written by Anthony Meder

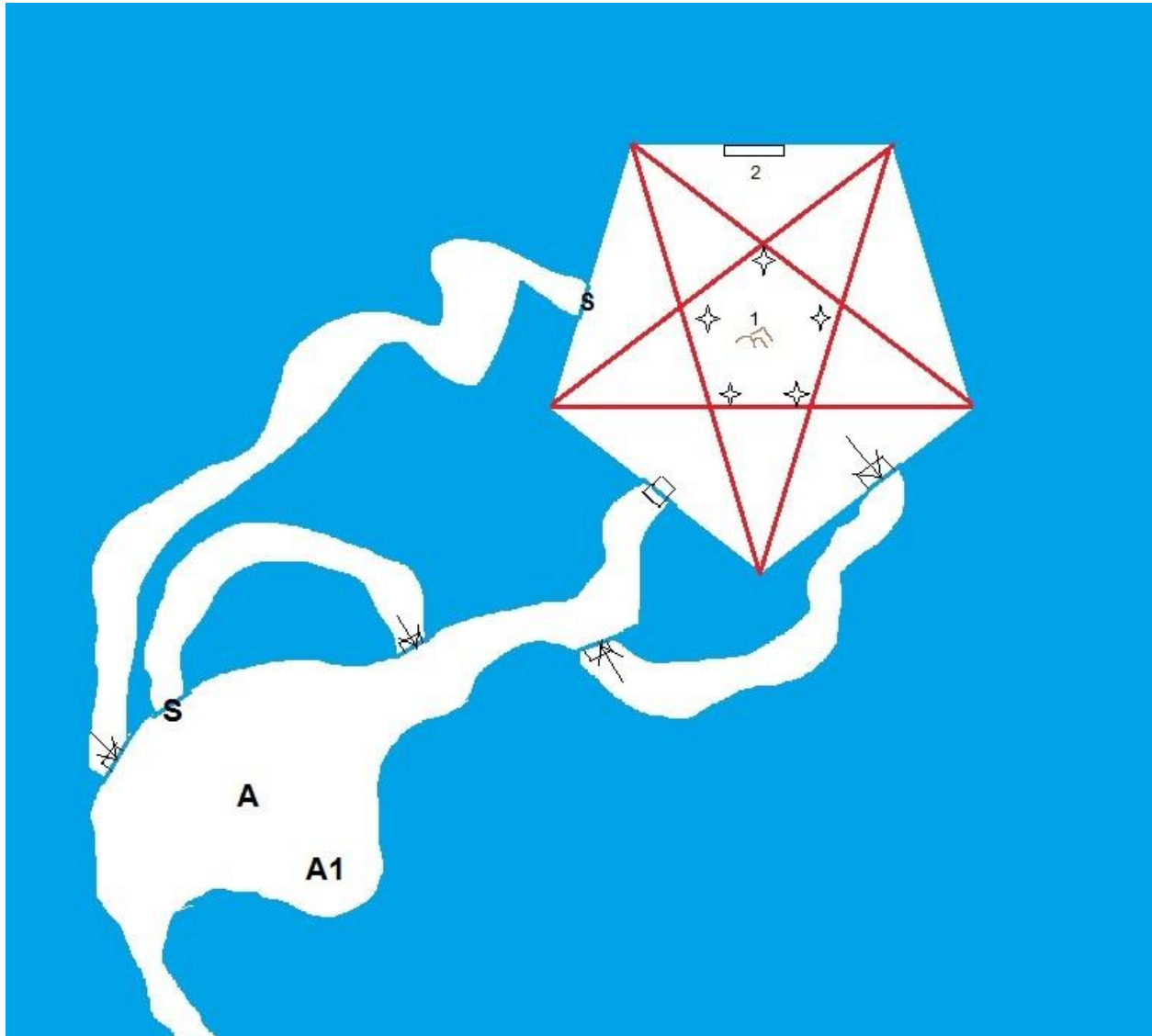

Chamber A

Chamber A is almost wholly non-descript. An irregular cavern, approximately 50' across with a bit of normal debris and detritus scattered about. The ceiling is lost to the shadows about, about 25' above their heads. NOTE: in the NW-ish wall is a well-made secret door. Also, there are 2 one-way doors leading into the chamber and the path leading to the pentagon room.

However, at about A1, the group will notice a bit of nearly disintegrated rags and a bit of remains of... something. They have been there a LONG time and it really isn't to discern much other than human... or humanoid. This poor soul has been decades dead. However, there is a pristine mace among the remains.

The Mace is magical and was once known as the *Mace of Malarthi*. It is a Mace +2, +3 vs. undead. Even more important, it is intelligent.

- INT: 13; communicates via telepathy with its wielder (the wielder just hears the mace in their mind).
- In addition to +2, +3 vs undead, the mace can Detect Magic in a 1" radius. The wielder must draw the weapon and concentrate on Detecting Magic (cannot attack, defend, or otherwise be engaged or the Detect is broken)
- It is also a Slayer of Evil... a successful 'to hit' roll against an evil opponent will paralyze the opponent for D4 rounds.
- NOTE: The mace will let the wielder know of its detect magic powers as well as its special foes of undead and evil in general
- The mace is NG alignment. It has an ego of 24. It will cooperate with any good aligned character. If it is used in a manner contrary to good, there is a test of wills between the wielder and mace (see DMG about intelligent swords). This is where the mace's ego comes into play



BUT... the mace has been in 'Demon's Eye' for decades. The evil of the place has begun to corrupt the mace. The corruption is imperceptible but irreversible. When first used in combat, the Mace has a 2% chance to Gate in a Type II Demon (Hezrou). The probability aggregates for each encounter (NOTE: the intent is not +2% every swing or foe, but every encounter... basically whenever drawn for a battle). So, the second encounter, there is a 4% chance, 6% on the third, etc. As the potential increases, good-aligned characters will sense the trouble

At 10% (5th encounter) LG characters will feel unease with the Mace. Once the probability exceeds 20%, the LG character will realize what is happening and can abandon the Mace without penalty, if they choose. If they continue to use the mace, the DM should consider alignment shift over time.

For NG and CG characters, the unease sets in at the 18% probability and they become sure once the probability exceeds 28%. If they continue to use, similar penalties may apply.

If a Type II Demon is gated in, the Mace shifts to CE alignment. The character wielding the mace will feel the flood of evil and discord. If the PC announces immediately dropping the mace, let them do so with perhaps some small penalty (-2 to hit due for d4 rounds to the trauma of it... temporary -1 to an attribute perhaps)

If any good-aligned character continues to use the mace once its corruption is known by a successful gate, continued use should be considered the PC using a cursed weapon. Also, there could be alignment shifts and there will certainly be contests of will between the mace and wielder.

Pentagon Chamber

Upon entering the chamber, the first thing noticed will be the sickly yellow light that illuminates the chamber. In that light, the party notices a room quite different from the last in that the walls are very straight and deliberate. (The party may, if they have a strong mapper and want to do it, notice the room is pentagon-shaped). Looking from the entry in the SW corner, a number of red brick paths (about 5' wide) are set into a flagstone floor. (This is obviously a constructed and maintained chamber, unlike the cavern prior... why?) The paths connect the 5 corners of the room. At each corner, set into the wall about

6 feet up, are the candles responsible for the sickly yellow light. The candles are quite large and look like they could last for a day or more... but where is the wax that should be gathered below?

Other than the entrance just used, there is a secret door in the NW wall that leads to a passage back to the first cavern. Also, a 1-way door from the SE wall section that leads to the 1-way door leading into the tunnel that the party just came through.

At point 2. there is a lever protruding from the wall about 4' up from the floor. It seems to be in the neutral position, meaning it could be moved to the left or right.

Point 1 may be what draws the party's eye though. In the center of the chamber is a small mound of disturbed dirt... the flagstones have been pried up and set aside. Next to the mound is a small spade shovel and surrounding the mound at intersection points of the red brick paths (as indicated on the map) are 5 statues. Two are humanoid, about 7' tall, bloated looking but with a lizard-like head (These are Type II demons (Hezrou). Another is a beautiful woman, tall (6') but, instead of hair, has a head of snakes (Medusa). The 4th is a wizened looking slight man (about 5' 6" tall) (a Wight). The 5th is a non-descript looking man of nearly 6' in height.

NOTE: The first 4 statues... the Hezrous, Medusa, and Wight are actually creatures that have been turned to stone by the Medusa (at some point, she saw her own reflection). The 5th is just a statue. I leave it to the DM to decide which statues are located where.

Near the turned dirt lies an easily seen highly polished silver mirror (value 200 gp). It is about 2x the size of a person's hand. If the party digs in the turned dirt, it takes 3 or 4 scoops to find a small chest. A total of 1 turn of digging will uncover the chest enough to open it. The chest is neither trapped nor locked. The contents of the chest: 4,124GP, a ruby that looks remarkably like the eye in the demon statue (value 1,000 GP, may or may not be the missing eye), a potion (cure poison), and a scroll (Prot. From Demons... 10' radius, 5d4 rounds duration. This is a power scroll and takes 1 full round to read. But it does protect against all Demons, even Princes.

The Shovel

If the party did NOT use the found shovel to dig, they should have no troubles. However, the shovel has an undetectable enchantment on it... it is an 'anti-gorgon' shovel. If the shovel is used to dig, the enchantment will de-petrify the creatures. It is suggested that the creatures are fully flesh as the party finishes unearthing the chest. If the party is being attentive to their surroundings, they will likely notice the change in the 4 statues. If not, they transformation is



quiet enough that it will not be noticed over the sounds of digging. It is suggested that 2d6 rounds after their transformation, the creatures are ready to engage (of course, the DM may choose which creatures are ready at which point in time as well). The party finds themselves up against a Medusa, 2 Hezrou, and a Wight. It is entirely possible for the Medusa to, either willfully or accidentally, gaze upon any of the creatures and have a chance to again turn them to stone.

Hezrou (Type II Demon): AC: -2; MV 6'/12" swim; HD 9 (49, 44hp); AT 3; Dmg: 1-3/1-3/4-16; Magic resistance: 55%. Special: **Darkness** at will 5' radius. One at a time, at will: **Cause Fear** (per the wand: causes a cone 6" long with 2" base diameter of amber light to flash for 1 segment. Anyone touched must Save vs. Wand or run from the Hezrou at 2x speed for 6 rounds), **Levitate** as an 8th level MU (Range 16", duration 8 turns, levitate (raise up, no horizontal movement) up to 8,000cn (800 lbs.), if on itself can move up 20' per round. If cast on another, the Hezrou can levitate that person up to 10' per round), **Detect Invisibility**, **Telekinesis** (3,000 cn), **Gate** (gate in Type II demon with 20% probability of success)

Medusa: AC 5, MV 9", HD 6 (30 hp), At: Special, LE. Attack... prefers to Gaze with 3" range. If successful, save vs. petrification or turn to stone. If the target averts their eyes, the Medusa rushes up. The asps that are her 'hair' will bite (if within 1 foot). A hit means the target saves vs poison or dies.

Wight: AC 5, HD 4+3 (hp 27), At 1, Dmg 1-4 + special, MV 12". Upon a successful hit, the Wight drains 1 level. Magic or silver weapons required to hit the Wight. It is immune to sleep, charm, hold, or cold spells. Poison and paralyzation have no effect. A Raise Dead spell will destroy the Wight. A vial of holy water does 2d4 damage (thrown, typically).

Mirror Quandary – Written by Brandon Gallant

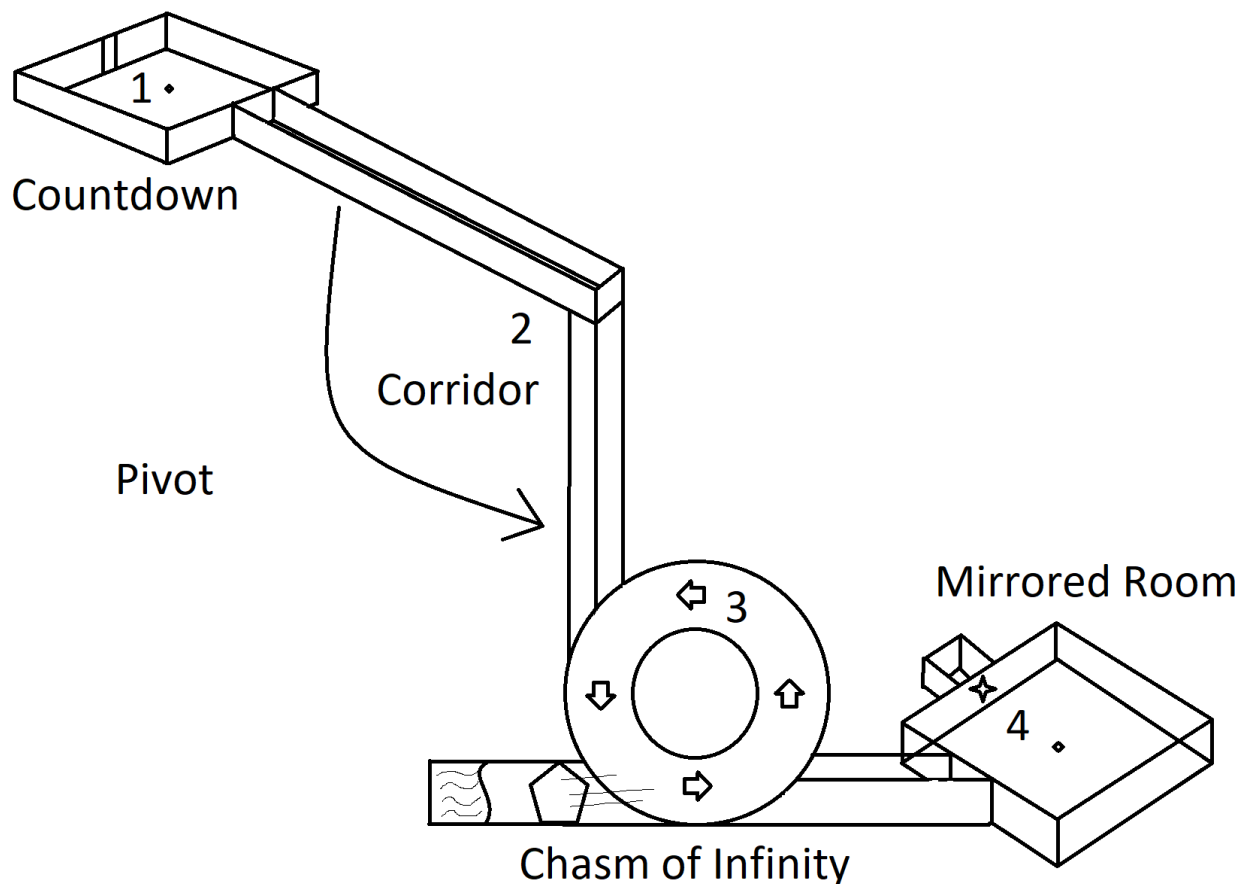

1 - Countdown

The door opens into a large square room completely devoid of character. The walls are smooth and everything – walls, floor, and ceiling - glows a soft white. In the exact centre of the room is a 3-foot-tall pedestal with a button on top. The room is 50' square, and nothing happens until the last PC enters the room. At that time, the door slides closed silently behind them, sealing everyone inside. At this time, the DM – in their most booming voice - begins to count down in real time from 20.

Allow the PCs to panic and decide what to do in real time during the count down. NOTE: The only real option is to press the button on the pedestal. Doing this resets the clock to 20, allowing the group more time to argue and plan. When the timer hits '0', there is a hissing sound, and the wall on the opposite side of the room opens, allowing the PCs to exit the room.

2 - Corridor

The door slides closed behind the last PC, plunging everyone into magical darkness. Dark vision is of no use, and the PCs are forced to move along the corridor blindly. The 200' corridor ends at a dead end. The wall at the end of the corridor, however, is covered in ancient runes that begin to glow menacingly once the PCs are within 10 feet. A successful Read Magic will reveal the translation:

This is the end of your journey, yet only the beginning.

The finite becomes infinite and all points forward lead the way back, and down. Goodbye.

Reading this aloud causes the trap mechanism to engage, at which point gravity seemingly shifts and the PCs feel themselves being pulled away from the runes (which stop glowing as the group moves 10 feet away). In reality, the entire 200' corridor is pivoting, with the dead end acting as the pivot point, turning the entire corridor into a vertical shaft. All of this is being done in magical darkness.

3 - Chasm of Infinity

At the end of the corridor / shaft's new position is a large circular tube with smooth edges and nothing to allow an arrest of movement. A large wind turbine, powered by forces unknown, keeps a steady air current flowing around the tube fast enough to keep the party in the air and circulating around the tube.

The magical darkness is still in effect and it should feel to the PCs, for all intents and purposes, that they are falling down a seemingly bottomless pit. The same booming DM voice returns, laughing menacingly.

"Welcome to the Chasm of Infinity. Do you fall forever? Or to your doom? There is but one way out. Solve my riddle and pay the consequences. 'You see me in water, but I never get wet. What am I?"

The answer is 'a reflection'. Allow for up to 5 to 10 minutes of real time puzzling (depending on how much time is left in the session) and if there is no answer forthcoming from the group, allow the players to make intelligence checks. The answer reveals itself to anyone passing the check. In either event, once the answer is given, the tube rapidly fills with water and a trap door opens to another horizontal corridor, plunging the party harmlessly into a fast-moving river, sweeping them into the Mirrored Room.

4 - Mirrored Room

The floor of this room is a completely made of grate, and the river deposits the party into the room before disappearing down the grate. The door behind them closes, again plunging the party into complete darkness for a moment, at which time the ceiling starts glowing a soft white light. The party find themselves in another 50' square room, but the walls are completely mirrored, giving the effect of infinity in all directions. Within one mirror is an IRON CHEST, which exists only within the mirror, and not in the room itself. At this point, have the party roll for initiative as an exact copy of each PC steps out of various mirrors and attack their counterparts. The mirrors cannot be destroyed.

DM NOTE: These mirror copies are identical to each PC in every way, with the exception that they have exactly HALF the hit points of their copy and when killed, they shatter as glass, doing 2D6 damage to all within 10 feet of the shattering figure. Mirror images will attack their own PC only but can be harmed by any and all PCs. Once all mirror images have been destroyed, a 2-foot section in the middle of the floor grate opens up and THE LEVER lifts out of the floor. In addition, the mirror with the IRON CHEST shatters (doing 2D6 damage to all within 10 feet) and reveals a small 5' square room containing the IRON CHEST. Pulling the lever in any direction opens a random door in the Main Chamber.

THE DEMON'S EYE - Funhouse

Written & Designed by Chris Larr

Demon's Eye - The Funhouse (map)

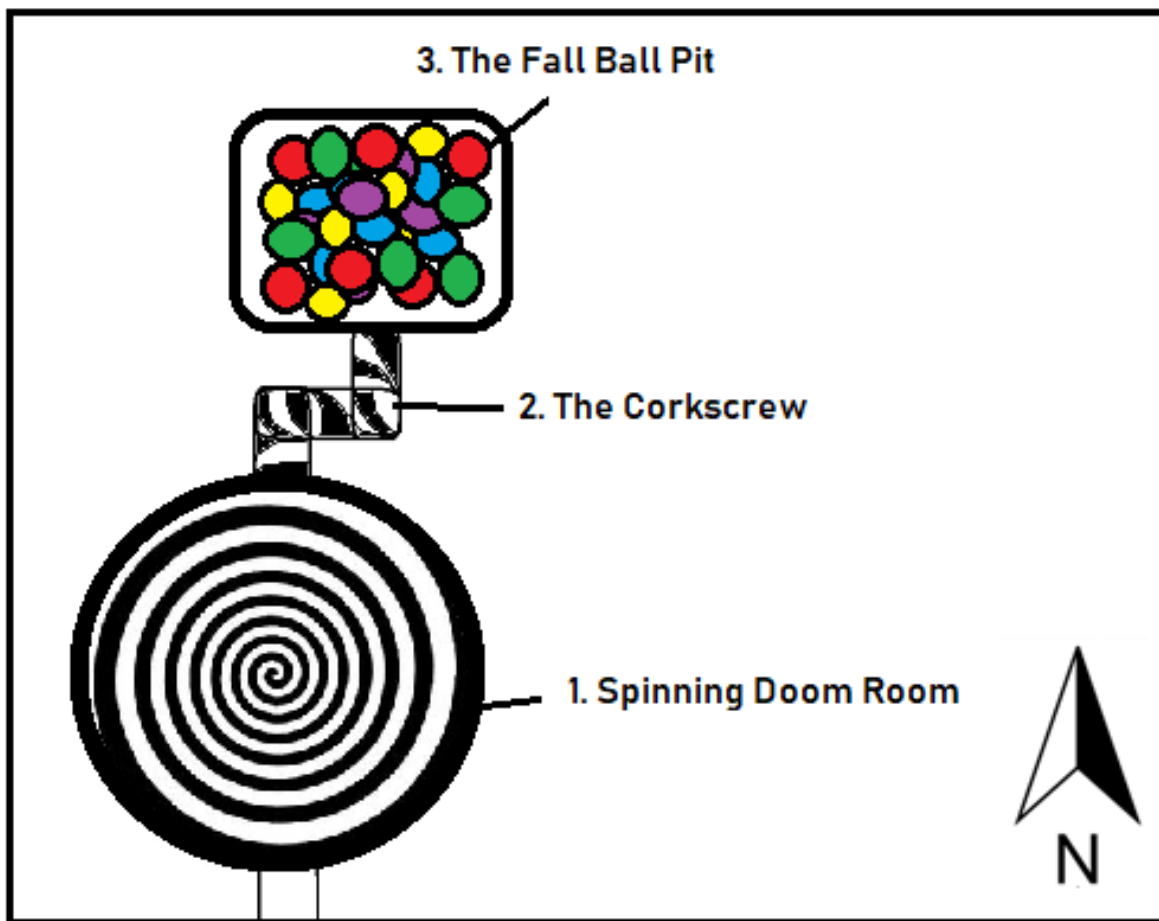

Dungeon features: Floor to ceiling is 10 feet. The walls, ceiling, and floors are made out of what appears to be cobblestones, each being a differently vibrant color. The cobblestones are arranged in an almost mosaic-like pattern with the result being a mixture of chaotic spirals and random spirals – almost like what would be seen in a circus or funhouse. Music, similar to a circus organ, plays incessantly in the background. As one progresses through this section of *Demon's Eye*, the music gets louder until reaching area 3.

1. **Spinning Doom Room:** This is a large circular room with a large disc hovering in the center of the room. Everything else is void (falling into the void would result in certain death). The disc is stationary, level, but spinning very fast in a counter-clockwise direction. No spell or magic-item can affect the structure or function of the disc. Spells, however, will function normally in other parts of the room. The disc has a bright red spiral painted throughout it, adding to the bizarre randomness of the room.

Unless aided by spells (such as *Fly* or *Jump*) or magic items (such as *Boots of Striding and Springing*), players will need a successful dexterity roll to leap over the void onto the disc. Players who are heavily armored (or otherwise encumbered) will receive a -2 to -4 penalty (based on the level of encumbrance and at the discretion of the DM).

Characters who stand on the spinning disc will receive -2 penalty on all melee attacks and -4 on all missile attacks. Furthermore, **every round** a character remains on the disc, a successful DEX roll will need to be made or the character will be flung off the disc by centrifugal force, smashed into a wall for 6d4+6 points of damage, and then fall into the void (at the DM's discretion, characters can make a single attempt to reach out and grab hold of the disc as they fall). *Spider Climb* or similar magics will allow a character to prevent from being flung from the disc, but penalties to attack will still apply.

Atop the disc are **12 Pierrotoxi [AC 1, HD 4+4, HP 27, 25, 24, 22, 21, 21, 20, 19, 19, 16, 15, 14; ATK 2, DAM 2-8/2-8, SA: Confusion, SD: Half-damage from lightning, fire, cold, gas attacks; MR 15%]** These horrid sub-demons can move effortless and freely on the spinning disc (including moving to the other side of the disc, only to run back to the original side at a different location). They suffer no penalties to attack. If somehow flung off the disc, they can adhere to the walls, climb easily up them, and then jump back onto the disc to continue the attack.

The moment the PCs enter the room, the Pierrotoxi will spread out, with some of them leaping from the disc towards the PCs (either using the disc to fling themselves directly at the PCs or leaping to a wall and running along it towards them) while others will begin their dance in an attempt to confuse the intruding characters.

The Pierrotoxi will attack until slain. If the characters escape the room, any surviving Pierrotoxi will pursue them relentlessly.

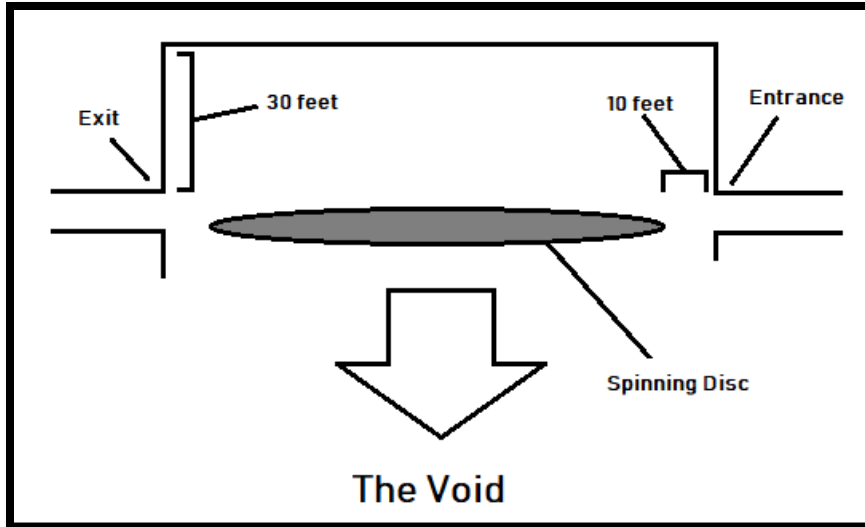

Cross Section of Room 1 (Spinning Room)

2. **The Corkscrew:** This section of the hallway is a circular tunnel (instead of a square) and the walls are incredibly smooth and slick. The tunnel has a black/white spiral design throughout it. The strange music is louder and echoes chaotically in this area.

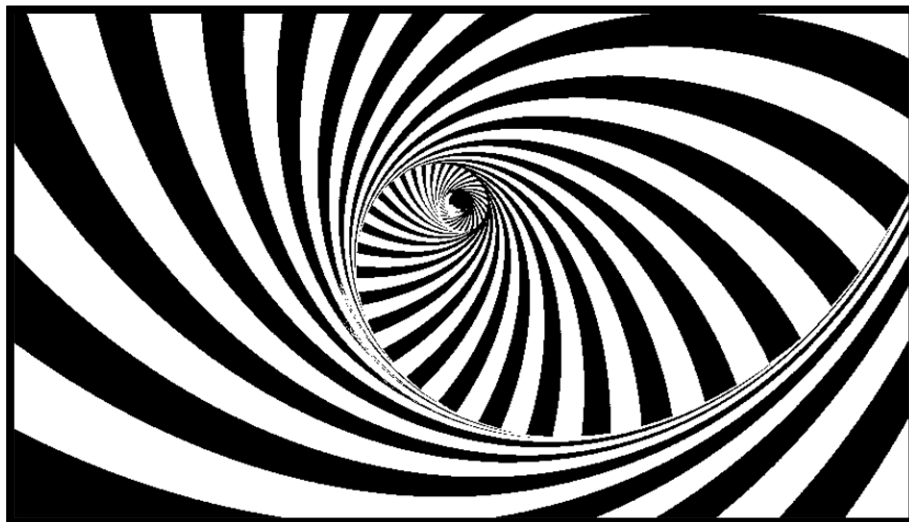

A strange, transparent, oily-substance lines the entire surface of the tunnel making it slippery and slick (it cannot be removed, burned away, etc. It is an innate part of the material that makes up the tunnel). It is near impossible to remain standing in the tunnel without slipping and falling down (in fact, a successful DEX roll at -4 must be made each round to remain standing [or stand up if fallen]). Magical means of adherence, such as *Spider Climb* spell will function normally.

The tunnel drops into a steep spiral descent for almost 300 feet. It takes 30 melee rounds to descend at full speed. If descending at full speed, characters will spin uncontrollably in throughout the tunnel via centrifugal force. The following effects will be in effect:

- **Spellcasting:** Any spells involving material components will automatically fail. Any spells involving just somatic and/or verbal components will have a 50% chance of failure (penalty reduced by 10% for each point of DEX over 15).
- **Scrolls:** There is a 70% chance the spell will be ruined (penalty reduced by 10% for each point of DEX over 15).
- **Potions:** There is 70% chance potions will be dropped during the descent (penalty reduced by 10% for each point of DEX over 15).
- **Wands/Rods/Staves:** There is 50% chance wands/rods/staves will be dropped during the descent (penalty reduced by 10% for each point of DEX over 15).
- **Missile attacks (bow, crossbow, slings):** Attacks are made at -4.
- **Melee attacks:** Attacks are made at -4 for large melee weapons (longswords, pole arms, battle axes, etc.). Attacks with small melee weapons (such as short swords, daggers, hand axes, etc.) are penalized at -2.
- **Armor class:** There is a base AC penalty of +4 (reduced by magic armor, dexterity, etc.).

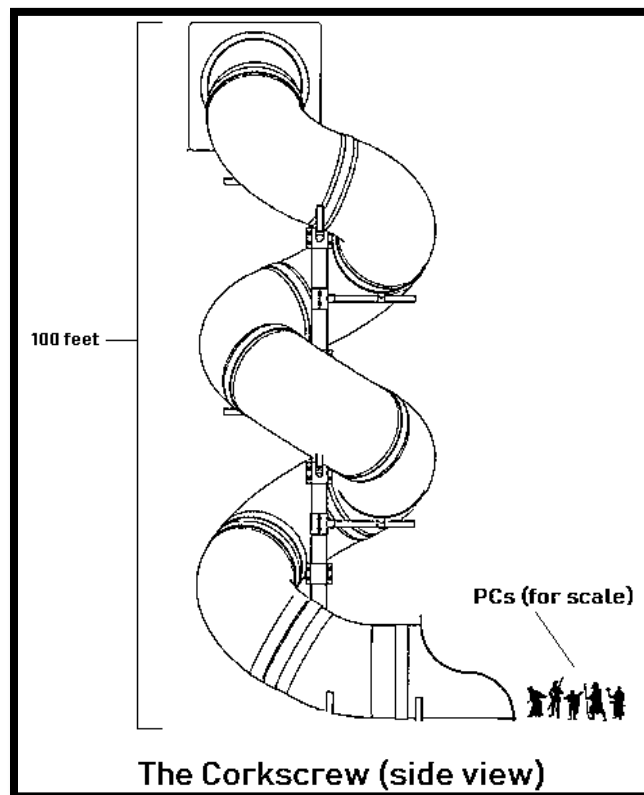

Dwelling in The Corkscrew are 9 Pierrotoxi [AC 1, HD 4+4, HP 36, 34, 31, 29, 29, 28, 21, 19, 17; ATK 2, DAM 2-8/2-8, SA: Confusion, SD: Half-damage from lightning, fire, cold, gas attacks; MR

15%] who will attack the characters as they descend. Due to their supernatural contortion and climbing abilities, they receive no penalties whatsoever to their AC, magical abilities, or attacks. Furthermore, the Pierrotoxi can effortlessly slide down the Corkscrew, control their descent, and stop at will, but they cannot use their dance ability while actively descending. They will use the features of the Corkscrew to their greatest advantage.



3. The Fall Ball Pit: The corkscrew slide empties into a giant (300 ft tall by 200 ft wide) pit filled with thousands of multi-colored balls. The music is loudest in this room, an organ-grinder sounds emanating from all directions. No damage is sustained from the fall. The balls are made of some strange, flexible material similar to rubber. There is nothing unique or extraordinary about the balls. However, when in the pit, the following penalties apply (negated by spells such as *Spider Climb* or magic items like a *Ring of Free Action*):

- **Armor class:** There is a base AC penalty of +2 (reduced by magic armor, dexterity, etc.).
- **Melee attacks:** Attacks are made at -4 for large melee weapons and -2 for small melee weapons.
- **Missile attacks:** Surface attacks are made at -6 (when sinking, covered by balls, missile attacks will automatically fail unless magically guided [such as a *Javelin of Piercing*]).
- **Movement & Vision:** Movement is reduced by 75%. Characters will slowly sink towards the bottom of the pit (taking 20 melee rounds to sink to the bottom). When inside the pit, vision is obstructed which will make reading scrolls more difficult [reading time is tripled]).

At the ceiling are 5 multicolored boxes (red, orange, yellow, green, purple). They are firmly affixed to the ceiling and cannot be peered into (short of a *Wish* spell). Each box is sturdy and can sustain 100 HP damage before being shattered. Should a box sustain 100+ HP damage, the box will shatter, and the contents will spill down into the room.

At the bottom of the pit are 5 levers (red, orange, yellow, green, purple). When a lever is pulled, the contents of the corresponding box will open and fall into the pit. The contents of each box are as follows:

- **RED:** 6 Pierrotoxi [AC 1, HD 4+4, HP 35, 32, 30, 29, 23, 14; ATK 2, DAM 2-8/2-8, SA: Confusion, SD: Half-damage from lightning, fire, cold, gas attacks; MR 15%], contorted into the box, are released, will fall into the pit, and will begin to work their way down to attack the PCs. The Pierrotoxi suffer no penalties with regards to movement, AC, or attacks. They will attack viciously, yet intelligently, until slain.
- **ORANGE:** 5 items spill out of the box and fall into the pit:
 - *Wand of Magic Missiles* (13 charges).
 - *Potion of Extra Healing* (4 doses).
 - Scroll [bone scroll case] I – *Clerical* (level 9): *Cure Critical Wounds, Neutralize Poison, Dispel Magic, Spiritual Hammer, Bless.*
 - *Iron Stone* (pale green): Adds 1 level of experience.
 - **Sustainer:** +1 *Longsword* (when wielded, acts as a *Ring of Protection +1* [AC + saving throws] and reduced any damage taken by 1 HP per attack [so if hit for 6 points of damage, the wielder only takes 5 points of damage]).
- **YELLOW:** 4 *Bloodworms (Fiend Folio p15)* [AC 4, HD 6, HP 40, 35, 31, 22; ATK 1, DAM: 1-8 + Blood Drain, SA: Nil, SD: Nil; takes double-damage from all fire attacks and saves at -2 against magical fire] fall into the pit and will immediately swim towards the first living thing they sense. They are ravenous and will attack viciously and unceasingly. Their attacks, AC, and movement are not penalized by the pit.
- **GREEN:** A small, wooden chest falls into the ball pit (the chest is not damaged in the descent as the balls will break the fall). The chest is locked and has 2 traps that must be disarmed to safely unlock and open the chest - If a thief/assassin attempts to use *Open Locks* and/or *Find/Remove Traps* skills while IN the pit, then there is a 25% penalty applied. Traps are as follows:
 - Trap #1: Poison needle trap (save vs poison at -2 or lose 50% of HP each round until dead).
 - Trap #2: Poison gas bladder (sprays poison gas into the area. All within a 20 foot radius of the chest must save vs poison at -1 or lose 2 points STR, DEX, CON for the remainder of the adventure).If the traps are successfully disarmed and the lock opened (if the chest is simply smashed or opened by brute force, then there is a 85% chance that each item will be destroyed). The contents of the chest are as follows:
 - *Scroll* [silver scroll case] – *Magic User* (level 11): *Monster Summoning III, Polymorph Self, Blink, Strength, Enlarge.*
 - *Potion of Hill Giant Strength* (1 dose).

- **Forsaker:** *Magic Dagger* (when wielded, if the wielder is willing to sacrifice 2hp, then a +1 additional bonus 'to hit' is afforded. Each round, up to 6hp can be sacrificed [+3 'to hit' bonus]).
 - 4 gemstones: Diamond (2500gp), Ruby (1750gp), Amethyst (900gp), Topaz (450gp).
 - *Ring of Free Action.*
- **PURPLE:** The box will open and confetti will shower out. The confetti is golden and silvery in color, very reflective, and will coat everything they adhere to. The glitter makes it easier for enemies to hit (+1 bonus 'to hit') and will also confound a thief's/assassin's ability to *Hide in Shadow* by -25%. However, this is also **the lever** which will open a random door in the dungeon, allowing players to progress.

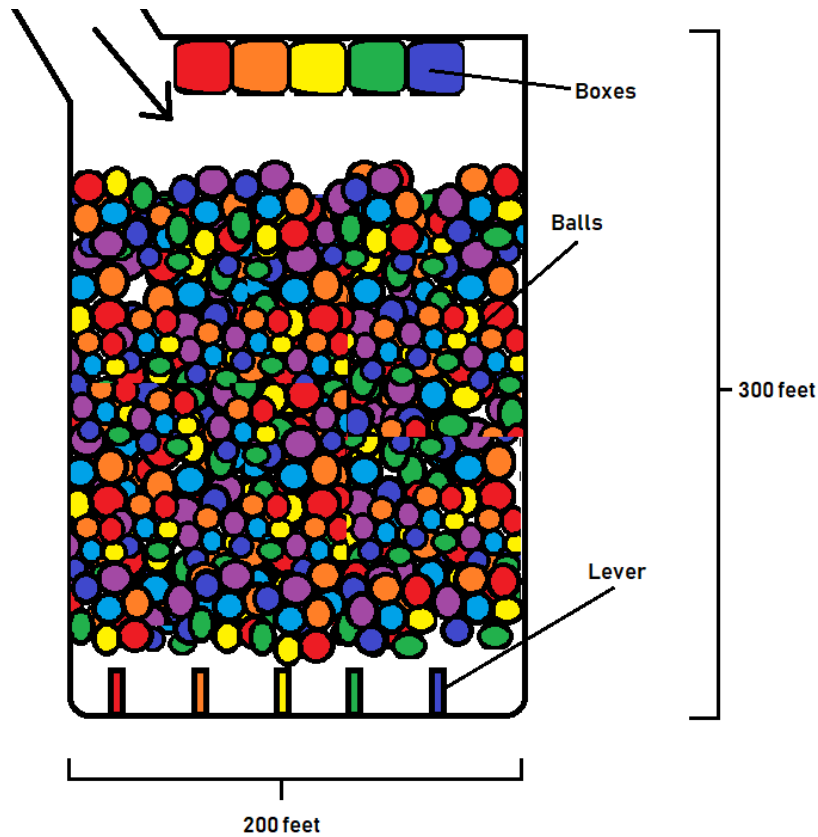

Appendix (new monsters)

PIERROTOXI (sub-demon)

FREQUENCY: Very rare
NO. APPEARING: 4-16
ARMOR CLASS: 1
MOVE: 15" + special
HIT DICE: 4+4
% IN LAIR: 100%
TREASURE TYPE: B
NO. OF ATTACKS: 2
DAMAGE/ATTACK: 2-8/2-8
SPECIAL ATTACKS: Confusion
SPECIAL DEFENSES: Special
MAGIC RESISTANCE: 15%
INTELLIGENCE: Low
ALIGNMENT: Chaotic Evil
SIZE: M
PSIONIC ABILITY: Nil
Attack/Defense Modes: Nil



Pierrotoxi are a particularly horrid variety of sub-demon that are "employed" by Demon Lords (and sometimes loaned to valued servants) to serve as guardians of tombs and treasure. Pierrotoxi are extraordinarily fast and agile (which accounts for their low armor class) and able to run up walls and ceilings similar to a *Spider Climb* spell with no loss of speed or momentum. While possessing a humanoid form, Pierrotoxi can bend their joints in any direction they desire, allowing them to contort into unnatural positions (and can pass through narrow openings and corridors that would normally be impossible for the normal humanoid frame). It is impossible to successfully grapple a Pierrotoxi.

Pierrotoxi attack twice per melee round with claw attacks, each doing 2-8 points of damage upon a successful hit. Alternatively, Pierrotoxi can forfeit their attacks and dance (which involves bizarre and disturbing movements using their contortion abilities) – the effect of which can cause *Confusion* (similar to the 7th level Druid spell of the same name, but at 4th level ability). Victims must be able to see the dance to be affected by it... save are vs petrification/polymorph (as opposed to spells).

Pierrotoxi, like all demons, receive only half damage from lightning, fire, cold, and gas attacks.

Description: Pierrotoxi appear as slender, gaunt, humanoids with alabaster skin, jet black facial outlines, and long, multi-jointed fingers ending in claws. The mouth of a Pierrotoxi is twisted into thin, insane smiles lined with thin, needlelike teeth.

Pumpkin Patch — Written by Daniel Ethridge

Chest Room

Entering through the door from the Main Chamber, a short corridor leads the party to another iron door. Unlocked and not trapped, entry here brings the group to the Pumpkin Patch. As the party opens the door to this room, they first notice that it does in fact look like a pumpkin patch, dozens of gourds, tendrils, and vines growing everywhere. Dark rough-



cut grey walls create an environment that is both spooky and mysterious. The ceiling is roughly 15' above their heads. In the center of the room sits an iron chest trimmed in copper on a raised 4-point star dais. Note: A closer inspection of the room uncovers another door on the opposite side of the room but nothing else out of the ordinary.

Inside the Iron Chest: A large red crystal in the shape of an eye (Fake but made to resemble the real thing). Approaching (within 10') the chest causes a magical trap to activate, animating 6 pumpkins and transforming them into monsters.

(6) Pumpkin Nightmares (demon) – MV 12, AC 2, HD 4+2, HP 21, 21, 23, 24, 25, 25, # ATK 1, DMG 1-8 vine whip (save vs poison against grapple), SA hurl flaming gourds for 4-10 damage, SZ M, 3 of the Nightmares contain a 100gpv gem



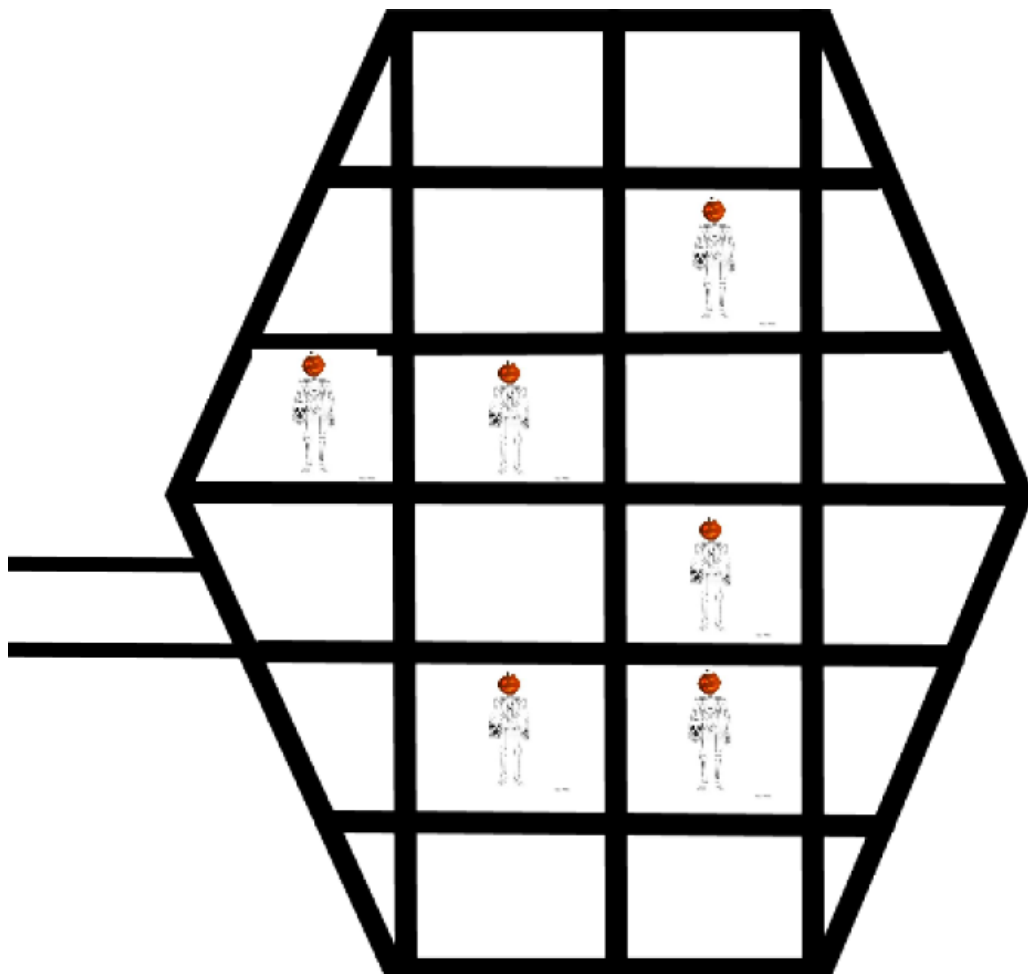

Decoration Room

Entering through the other door the party enters a room that looks like an oversized storage area, an assortment of bits, baubles, and decorations litter the entire area, most notably are a handful of strange pumpkin-headed skeletons.

Note: Most of the items in the rooms are worthless, however an extensive search of the room reveals a total of 50gp buried underneath a pile of rotting cotton and satin fabric and an iron lever against the wall opposite of the entrance door. (Pulling the lever down causes a random door in the Main Chamber to open while pulling the lever up closes the same random door.)

Touching or moving any object in the room causes the 6 of the creepy ass desiccated skeletons to spring to life and immediately attack the party!

(6) Jack-o-Bones (undead / ghoulish level in terms of turning) – MV 8, AC 5, HD 4, HP 24, 24, 24, 25, 26, 29, # ATK 1, DMG 1-6 rusty short sword, SD +1 or better to hit, silver weapons deal double damage, never groups together, always stay spread out, SZ M

Blood Stone – Concept by Michael Pritchard, Written by Chuck Green

1 – The Black Hall

Through the main chamber doors, the party finds themselves delving down a stone staircase into a wider hallway. This wide hall winds its way around the dark black stone eventually finding a large square room roughly 35' by 35'.

2 – Room of Levers

Three iron levers can be seen on the far wall while the floor is covered in both dust and debris. In the far corner are what looks like the remains of some giant winged beast, possibly a griffon or a manticore? An iron door on the south wall leads to another section of the dungeon. An extensive search of the room, specifically near the skeleton, reveals a single silver coin. The face of the coin shows it comes from an ancient civilization long gone from this world.

*Pulling down the lever on the right opens a random door in the Main Chamber. Pulling it up closes the same door.

*Pulling the lever in the middle up or down

opens the iron door on the south wall and releases a toxic smelling fume into the room. The door cannot be re-closed.

*Pulling down the lever on the left causes a whirling sound to emanate from the doorway on the south wall. Pulling the lever up causes the whirling sound to stop. If the south door is still closed, the whirling sound is more of a hum.

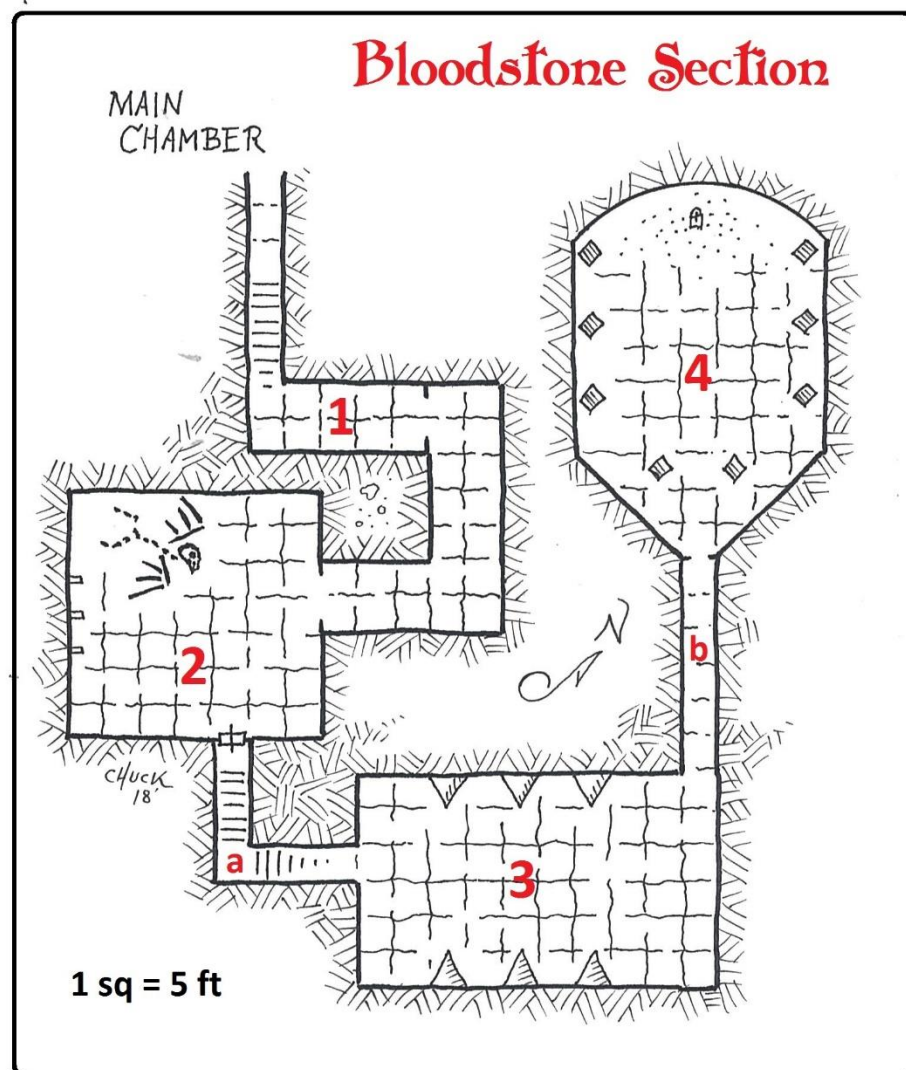

3a – Stairway to Death

Through the iron door the party finds themselves descending a steep set of stairs roughly 45° angle made entirely of black granite. The toxic fumes have not dissipated much and if nothing was done to prevent breathing them in, 1 point of damage is inflicted to all persons. The first set of steps end at a small landing where you find a large leathery-skinned grey egg. Past the egg are another set of steps leading you down into room 3.

If the egg is left alone, nothing happens, and everyone can go on their merry way. If the egg is touched, poked, or in any way bothered, it immediately hatches, the tip of the egg peels back like a series of flower petals, and a grotesque demonic creature immerses hellbent on tasting humanoid flesh!

Tiny Blood Demon – MV 16, AC 4, HD 4, HP 30, # ATK 2, DMG 1-4/1-4 claw/claw, SD immune to fire and acid damage, SZ S (3' tall)



3 – Blade Trap Room

Stepping down from the staircase the group finds themselves in a long room created from the same black stone. The ceiling in this room is nearly 20' high. On the left and right walls are what looks like steel spikes.

If the lever in room 2 was pulled down causing the whirling sound, these spikes are both spinning and thrusting out into the room. If the lever was not pulled down, the spikes are stationary. If spinning, each character must make a dexterity check to negotiate the blade trap and reach the other side.

3b – Dark Corridor

The party treks through a long and narrow corridor. Halfway down the hall they come upon another mysterious leathery egg. The same rules apply for the egg but if a demon emerges from it, it is a tad bit more powerful than the last...

Blood Demon – MV 15, AC 2, HD 6, HP 45, # ATK 2, DMG 1-6/1-6 claw/claw, SD immune to fire and acid damage, SZ M (5' tall)

4 – Mother's Nursery

The party enters a vast room full of dark and light-colored stones. The most vibrant room so far, square stone columns dot the outskirts of the chamber. On the far side of the room sits an iron chest. Its edges are trimmed in what looks like a blood red color. Five leathery eggs dot the room sporadically and centered among them is a tall female figure. Long black hair, cool pale skin, and vivid bright blue eyes, she holds an exotic type of sexual beauty. As you enter the room her face lights up with a warm smile.

“Greetings! I am very happy to see you! Welcome to my little nursery!” her sweet voice purrs.

Immediately, a wave of mystical energy erupts from the seductive female and stretches out in a sphere. All characters in the room must save versus spell or fall under her Hold Person spell. Regardless of result, three of her leathery eggs peel open and out of each emerge a foul sticky demon! Once reaching the ground, they instantly sprout up into formidable monsters!

(3) Large Blood Demon – MV 12, AC 1, HD 7, HP 49, 50, 51, # ATK 2, DMG 1-8/1-8 claw/claw, SD immune to fire and acid damage, SZ L (7' tall)

If any of the characters get within 20' of the mysterious female temptress, she will force three more of the leathery eggs to hatch, summoning three more large blood demons. If combat is forced on her, she will transform into her true likeness, a demonic tentacle beast, and she will attack!

Tentacle Mother Blood Demon – MV 18, AC -2, HD 8, HP 61, # ATK 4, DMG 1-4/1-4/1-4/1-4 spiked tentacles, SA can cast Hold Person every third turn effecting up to 6 persons, SD immune to fire and acid damage, SZ L (8' tall)

Inside the red trimmed iron chest, you find 250 silver coins and a small fist sized red stone.

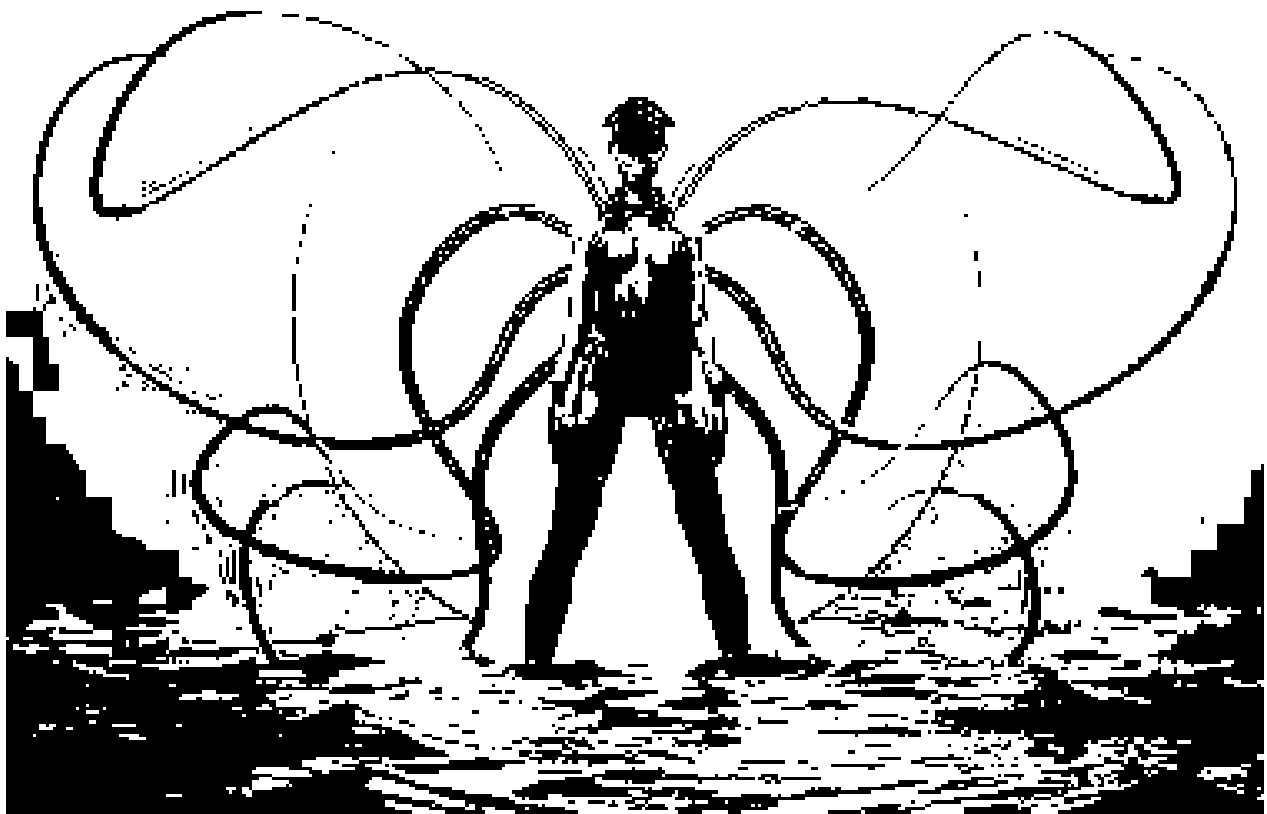

Aftermath –

Back in the Main Chamber, large red eye-shaped gemstone in hand, nothing seems out of sorts. It is an easy feat to climb up the giant demon statue, suspend just above the creepy crucified skeleton, and place the gem into the statue's eye socket. Once done, one of two things will happen...

*If the false eye from the Pumpkin Patch is placed into the eye socket, the skeleton bursts into animation screaming "YOU FOOLSSSSS!!! THAT IS THE WRONG GEMMMMMM!!!!!"

Immediately after, a black tar-like substance will ooze up out of the floor blocking access to the stairwell to the surface. Quickly, the tar takes shape and materializes into a humanoid shaped figure, bulging muscles, and flaming bright red eyes! Its mouth opens revealing nothing but emptiness...though it spits balls of sticky black burning tar!

Tar Elemental – MV 0, AC -2, HD 12, HP 92, # ATK 1, DMG 2-16 fist, SA a successful bite forces save vs paralysis or be disintegrated, spitting ball of tar deals 2-20 damage or save vs poison for half, SD immune to fire and acid damage, SZ L (9' tall)

If defeated, the ooze disappears, and the way is open.

*If the correct gem is inserted, the skeleton animates and laughs a maniacal laugh. He slides off of the nails holding him crucified to the statue, landing softly onto the stone. Slowly right before your eyes, his flesh returns to his withered bones. Also, his hair, a coal black color, grows out, his robes become whole again, a shimmering black and gold silk and satin material. He stretches his muscles in absolute ecstasy, tears of joy stream down his pale face. Once he recovers from his resurrection, he cuts his eyes at the group, flicks one hand, and a long sinewy staff made from humanoid bone appears in his hands.



"Thank you, friends. You have freed me from my false prison. This I will not soon forget. Alas, I must bid you farewell..." he hisses before bursting into a fiery smoke. When the smoke clears, he has vanished.

On the ground, where he vanished, you find a small onyx ring marked with a



NEW MAGICAL ITEMS (in alphabetical order)

Blood Stone – a small fist sized blood red stone. This stone has a small pulsing vibration like a heartbeat. If it is buried in soil, some scholars believe that something may grow...Found in the Blood Stone section.

Forsaker - Magic *Dagger* (when wielded, if the wielder is willing to sacrifice 2hp, then a +1 additional bonus 'to hit' is afforded. Each round, up to 6hp can be sacrificed [+3 'to hit' bonus]). Found in the Fun House section.

Mace of Malarthi - this mace is magical and was once known as the **Mace of Malarthi**. It is a Mace +2, +3 vs. undead. Even more important, it is intelligent. Found in the Medusa Garden section.

- INT: 13; communicates via telepathy with its wielder (the wielder just hears the mace in their mind).
- In addition to +2, +3 vs undead, the mace can Detect Magic in a 1" radius. The wielder must draw the weapon and concentrate on Detecting Magic (cannot attack, defend, or otherwise be engaged or the Detect is broken)
- It is also a Slayer of Evil... a successful 'to hit' roll against an evil opponent will paralyze the opponent for D4 rounds.
- NOTE: The mace will let the wielder know of its detect magic powers as well as its special foes of undead and evil in general
- The mace is NG alignment. It has an ego of 24. It will cooperate with any good aligned character. If it is used in a manner contrary to good, there is a test of wills between the wielder and mace (see DMG about intelligent swords). This is where the mace's ego comes into play

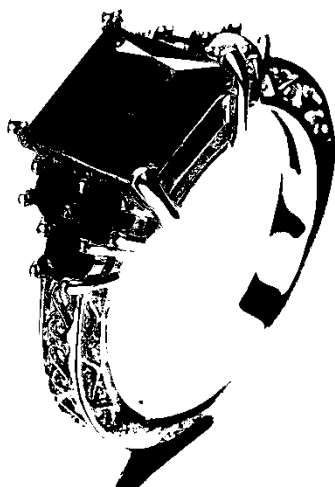

Sylamore's Gentle Caress – a single thin green malachite glove, grants the wearer +2 against petrification, attracts a swarm of gnats. Found in the Dragon Skull section

Vladimir's Onyx Ring – a small enchanted ring, crafted in silver, set with a small onyx stone. The wearer of this bauble can feel the general cardinal direction where the necromancer can be found. This ring is acquired in the Main Chamber after Vladimir is freed from his prison.

NEW MONSTER BESTIARY (in alphabetical order)

Blood Demon – these foul creatures come in different shapes and sizes though all of them are evil and nasty. Fighting with a claw/claw combination, they love to draw blood, and feast from their prey. They are all immune to fire and acid damage, their skin is a rough slimy scale similar to brimstone and have wicked sharp claws and teeth. They will always attack until either they are dead, or their prey has been slain. The three types of Blood Demons are:

Tiny Blood Demon – MV 16, AC 4, HD 4, # ATK 2, DMG 1-4/1-4 claw/claw, SD immune to fire and acid damage, SZ S (3' tall)

Blood Demon – MV 15, AC 2, HD 6, # ATK 2, DMG 1-6/1-6 claw/claw, SD immune to fire and acid damage, SZ M (5' tall)

Large Blood Demon – MV 12, AC 1, HD 7, # ATK 2, DMG 1-8/1-8 claw/claw, SD immune to fire and acid damage, SZ L (7' tall)

Tentacle Mother Blood Demon – MV 18, AC -2, HD 8, # ATK 4, DMG 1-4/1-4/1-4/1-4 spiked tentacles, SA can cast Hold Person every third turn effecting up to 6 persons, SD immune to fire and acid damage, SZ L (8' tall)

This version of the Blood Demon is unique. She can take the shape of a comely female to better lure in her prey. In her real form she has numerous spiked tentacles and a voracious appetite. She lays roughly 2-3 eggs per month though they do not hatch without her command.

Jack-o-Bones – these strange undead demon hybrids are sinister. Usually guardians of a tomb or library, they attack with their rusty swords or sometimes flails. Turned by a cleric like a ghoul, they are the body of a skeleton but the head of a jack-o-lantern. They are especially damaged by silver weapons.

Jack-o-Bones (undead / ghoul level in terms of turning) – MV 8, AC 5, HD 4, # ATK 1, DMG 1-6 rusty short sword, SD +1 or better to hit, silver weapons deal double damage, never groups together, always stay spread out, SZ M



PIERROTOXI **(sub-demon)**

FREQUENCY: Very rare
NO. APPEARING: 4-16
ARMOR CLASS: 1
MOVE: 15" + special
HIT DICE: 4+4
% IN LAIR: 100%
TREASURE TYPE: B
NO. OF ATTACKS: 2
DAMAGE/ATTACK: 2-8/2-8
SPECIAL ATTACKS: Confusion
SPECIAL DEFENSES: Special
MAGIC RESISTANCE: 15%
INTELLIGENCE: Low
ALIGNMENT: Chaotic Evil
SIZE: M
PSIONIC ABILITY: Nil
Attack/Defense Modes: Nil



Pierrotoxi are a particularly horrid variety of sub-demon that are “employed” by Demon Lords (and sometimes loaned to valued servants) to serve as guardians of tombs and treasure. Pierrotoxi are extraordinarily fast and agile (which accounts for their low armor class) and able to run up walls and ceilings similar to a *Spider Climb* spell with no loss of speed or momentum. While possessing a humanoid form, Pierrotoxi can bend their joints in any direction they desire, allowing them to contort into unnatural positions (and can pass through narrow openings and corridors that would normally be impossible for the normal humanoid frame). It is impossible to successfully grapple a Pierrotoxi.

Pierrotoxi attack twice per melee round with claw attacks, each doing 2-8 points of damage upon a successful hit. Alternatively, Pierrotoxi can forfeit their attacks and dance (which involves bizarre and disturbing movements using their contortion abilities) – the effect of which can cause *Confusion* (similar to the 7th level Druid spell of the same name, but at 4th level ability). Victims must be able to see the dance to be affected by it... save are vs petrification/polymorph (as opposed to spells).

Pierrotoxi, like all demons, receive only half damage from lightning, fire, cold, and gas attacks.

Description: Pierrotoxi appear as slender, gaunt, humanoids with alabaster skin, jet black facial outlines, and long, multi-jointed fingers ending in claws. The mouth of a Pierrotoxi is twisted into thin, insane smiles lined with thin, needlelike teeth.

Pumpkin Nightmare – an enchanted gourd, usually these creatures are the result of a powerful summoning spell, sometimes crafted by evil wizards or druids. Once activated, the gourd in question will pop up off of the ground demon possessed and grow an instant body from soil, vine, and magic. They try to grapple and strangle its prey when in close quarters but from a distance they prefer to hurl flaming gourds for more damage!

Pumpkin Nightmare (demon) – MV 12, AC 2, HD 4+2, # ATK 1, DMG 1-8 vine whip (save vs poison against grapple), SA hurl flaming gourds for 4-10 damage, SZ M

Tar Elemental – a very rare creature, these monsters are strictly created by powerful beings to protect or guard very dangerous or powerful magics. Immune to fire and acid damage, some scholars believe that inside its mouth is a true legit sphere of annihilation. Good luck.

Tar Elemental – MV 0, AC -2, HD 12, # ATK 1, DMG 2-16 fist, SA a successful bite forces save vs paralyzation or be disintegrated, spitting ball of tar deals 2-20 damage or save vs poison for half, SD immune to fire and acid damage, SZ L (9' tall)

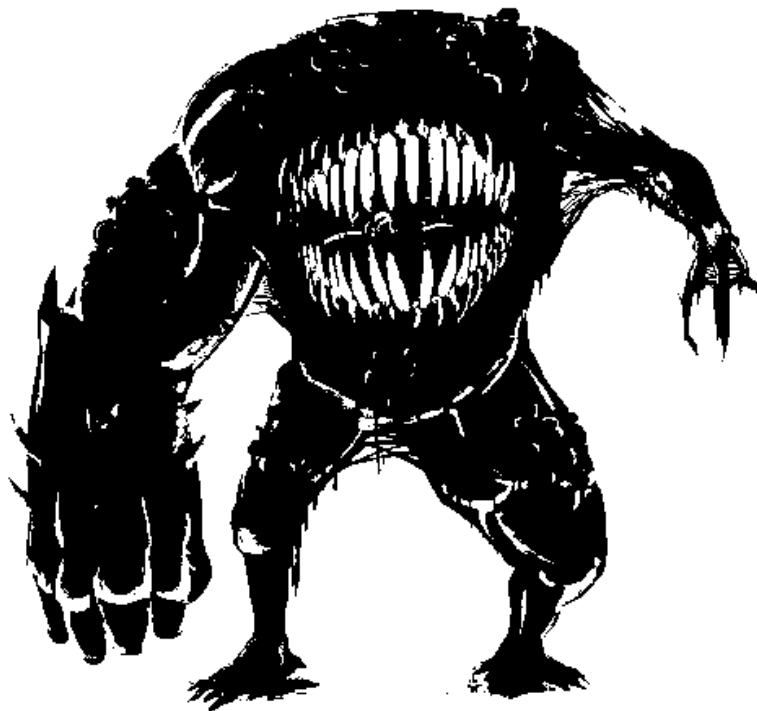

WEEPING ANGEL (Type II demon variation)



Stats by Chuck Green

| | |
|-------------------|---------------------|
| FREQUENCY: | Very rare |
| NO. APPEARING: | 2-5 |
| ARMOR CLASS: | -2 |
| MOVE: | 25" |
| HIT DICE: | 9 |
| TO HIT AC 0: | 12 |
| % IN LAIR: | 10% |
| TREASURE TYPE: | V |
| NO. OF ATTACKS: | 2 |
| DAMAGE/ATTACK: | 1-4/1-4 |
| SPECIAL ATTACKS: | Quantumport person |
| SPECIAL DEFENSES: | +1 or better to hit |
| MAGIC RESISTANCE: | 55% |
| INTELLIGENCE: | Low |
| ALIGNMENT: | Chaotic evil |
| SIZE: | M (6½' tall) |

"Whatever you do don't turn away, don't close your eyes, don't even blink! May the gods save us!"
-Sally Ninetails, lv8 magic-user

Classified as a unique type of demon, the Weeping Angel is one of the most frightening creatures a party can come across.

At first glance, they appear to be a standard statue of a serene angel, six and a half feet tall, and made of light grey stone. As they come closer, they take on a more feral appearance with sharp fangs and long talons.

Their main weakness is that they cannot move as long as someone is looking directly at them. This is called *quantum-lock*. Each turn that a PC is visible to the angel, they must save versus breath weapon or else blink/look away. If their prey looks away or even blinks, they move with amazing speed, attacking with their claws. On any successful hit, its victim must save versus petrification or be randomly *quantumported* into the past (1d20+99 years). All clothing, gear, and magic items drop to the ground as they disappear. Once destroyed, the Weeping Angel crumbles to a fine dust. One little known fact: If two or more angels are facing each other they become *quantum-locked*.

| | | |
|--|-------------------------------|---|
| Character Name: Sir Brandon the Gallant | |  Player Character Sheet for CAFCON 2019 www.cafconrpg.net |
| Class: Paladin | Level: 8 | |
| Race: Human | Alignment: Lawful Good | |
| Vision: Normal | Detections: None | |
| Racial Bonus: None | | |

| ABILITIES | | | | | | | | | | SAVING THROWS | | | | | |
|------------|-----------|----------------------------|----|-----------------------|----|------------|----------------------|----------------------|-----|-------------------------------|-----------|--------------------------------|-----------|-----------------------|-----------|
| STR | 17 | HIT ADJ | +1 | DMG ADJ | +1 | OPEN DOORS | 1-3 | Bend Bars/Lift Gates | 13% | Paralysis/Poison/Death | 10 | | | | |
| INT | 12 | | | | | | | | | | | Petrification/Polymorph | 11 | | |
| WIS | 15 | MENTAL SAVES | +1 | | | | | | | | | | | Rod/Staff/Wand | 12 |
| DEX | 17 | REACTION/ATTACK ADJUSTMENT | | +2 | | | DEFENSIVE ADJUSTMENT | | -3 | | | Breath Weapon | 12 | | |
| CON | 17 | HP ADJ | +3 | SYSTEM SHOCK SURVIVAL | | 97% | | RESURRECT SURVIVAL | | 98% | | Spells | 13 | | |
| CHA | 18 | | | | | | | | | | | | | | |

| | | | |
|-------------------|--------------------|--|--|
| HIT POINTS | ARMOR CLASS | ARMOR WORN | MODIFIERS |
| 76 | -6 | +3 Plate Mail, +2 Shield, Helmet (great), Boots (high, hard) | Shieldless AC: -3 Back AC: -3 |

WEAPON PROFICIENCIES: Broadsword, Hammer, Dagger, Spear, Battle Axe

| WEAPON | BASE DAMAGE (S or M/L) | NOTES |
|-----------------------------------|------------------------|---------------------------------|
| <i>Retributor</i> (Broadsword +3) | 2-8/2-7 | |
| <i>Evil's Eclipse</i> (Spear +2) | 1-6/1-8 | Double damage dealt when thrown |
| Battle Axe +1 | 1-8/1-8 | |
| Dagger +2 | 1-4/1-3 | |

| MAGIC ITEMS | EQUIPMENT |
|--|--|
| <p>Retributor: +3 lawful good Holy broadsword that (when wielded by a Paladin) grants total immunity to all forms of fear (magical or otherwise). When within a 25' radius of any chaotic evil creature or character, <i>Retributor's</i> blade will glow a brilliant white that is equivalent to daylight (and is powerful enough to overcome magical darkness, effectively dispelling it). Furthermore, Retributor is an intelligent sword with an INT 18, EGO 20 with a special purpose of slaying chaotic evil creatures (and will have no qualms about forcing its user to fulfill this objective).</p> <p>Once per day, the following Clerical spells can be cast when wielding <i>Retributor</i> (at 12th level Clerical ability): <i>Detect Charm</i>, <i>Detect Lie</i>, <i>Dispel Evil</i>, <i>Know Alignment</i>, and <i>Light</i>.</p> <p>Evil's Eclipse: +2 spear that deals base damage when used in melee, but double-damage when thrown.</p> | 10 spikes Mallet Large belt pouch Leather backpack 4 oil flasks |
| <p>+3 Plate Mail +2 Shield +2 Dagger</p> | <p>+1 Battle Axe Potion of Stone Giant Strength (1 dose = 5 turns) [Weight allow +5000gp, Damage bonus +9, BB/LG 60%, Rock hurling 16" range + 1-12 base damage]</p> |

| CLASS ABILITIES | |
|--|---|
| <ul style="list-style-type: none"> ▪ Detect evil (60' distance – must concentrate on determining the presence of evil) ▪ +2 on ALL saving throws ▪ Immunity to ALL forms of disease ▪ <i>Lay on Hands</i> (heals 2 hp/level – only once per day) ▪ <i>Cure disease</i> (twice per week) | <ul style="list-style-type: none"> ▪ Can turn undead as a 6th level Cleric ▪ If wielding a "Holy Sword", when unsheathed and held, projects a 1" diameter projection that can dispel magic at a level equal to the experience level of the Paladin. ▪ Continual <i>Protection from Evil</i> emanation – 1" radius |

| CLASS NOTES |
|--|
| <ul style="list-style-type: none"> ▪ May possess no more than 10 magic items (1 suit armor, 1 shield, 4 weapons, 4 other magic items). ▪ If Paladin should ever knowingly and willingly perform an evil act, all benefits of being a Paladin are lost and the Paladin is treated as a fighter (this can never be restored by any means). |

| | | |
|--|-------------------------------|--|
| Character Name: Ethridgian the Wise | |  DEMON'S EYE Player Character Sheet for CAFCON 2019 www.cafconrpg.net |
| Class: Cleric | Level: 9 | |
| Race: Human | Alignment: Lawful Good | |
| Vision: Normal | Detections: None | |
| Racial Bonus: None | | |

| ATTRIBUTES & ABILITIES | | | | | | | | | | SAVING THROWS | | |
|------------------------|-----------|----------------------------|------|-----------------------|----|----------------------|--------------------|----------------------|-----|-------------------------------|--------------------------------|-----------|
| STR | 16 | HIT ADJ | None | DMG ADJ | +1 | OPEN DOORS | 1-3 | Bend Bars/Lift Gates | 10% | Paralysis/Poison/Death | 7 | |
| INT | 10 | | | | | | | | | | Petrification/Polymorph | 10 |
| WIS | 16 | MENTAL SAVES | +2 | SPELL FAILURE | 0% | BONUS SPELLS | 2x1st, 2x2nd | | | Rod, Staff, Wand | 11 | |
| DEX | 16 | REACTION/ATTACK ADJUSTMENT | | +1 | | DEFENSIVE ADJUSTMENT | | -2 | | | Breath Weapon | 13 |
| CON | 18 | HP ADJ | +2 | SYSTEM SHOCK SURVIVAL | | 99% | RESURRECT SURVIVAL | 100% | | | Spells | 12 |
| CHA | 13 | | | | | | | | | | | |

| HIT POINTS | ARMOR CLASS | ARMOR WORN | MODIFIERS |
|------------|-------------|--|--|
| 60 | -2 | +1 Plate Mail, +1 Shield, Helmet (small), Boots (high, hard) | Shieldless AC: 0 Back AC: 0 |

| WEAPON PROFICIENCIES: Mace, Flail, Staff, Hammer | | |
|---|------------------------|--|
| WEAPON | BASE DAMAGE (S or M/L) | NOTES |
| Demon's Bane (Mace +2/+4 vs Demons) | 2-7/1-6 | Footman's mace (see <i>Magic Items</i>) |
| Hammer +1 | 2-5/1-4 | |
| | | |
| | | |

| MAGIC ITEMS | EQUIPMENT |
|--|---|
| Demon's Bane: Mace +2/+4 vs Demons; if a Demonic creature (excluding full-fledged Demon Lords) is hit on a natural 18-20, the Demon must save vs Rod/Staff/Wand or be instantly banished back to the Abyss. <i>Demon's Bane</i> also grants its wielder 25% magic resistance against all spells cast by demons. | Silver holy symbol 4 vials holy water 50-foot rope Tinder Box & Flint 6 Torches Leather backpack Silver scroll case 2 oil flasks |
| +1 Plate Mail | |
| +1 Shield | |
| +1 Hammer | |
| Potion of Flying (1 dose = 6 turns) [Allows flight as the 3 rd level magic-user spell, <i>Fly</i>] | |
| Scroll (Cleric – 13th level): <i>Animate Object, Blade Barrier, Conjure Animals, Cure Critical Wounds</i> | |

| MEMORIZED SPELLS | | |
|------------------|---|--|
| LEVEL 1 | 6 | <i>Bless, Command, Cure Light Wounds, Protection From Evil, Remove Fear, Resist Cold</i> |
| LEVEL 2 | 6 | <i>Chant, Find Traps, Hold Person, Resist Fire, Spiritual Hammer (x2)</i> |
| LEVEL 3 | 3 | <i>Animate Dead, Cure Disease, Prayer</i> |
| LEVEL 4 | 2 | <i>Cure Serious Wounds, Sticks To Snakes</i> |
| LEVEL 5 | 1 | <i>Flame Strike</i> |

| CLASS ABILITIES |
|---|
| Undead turning: The ability to turn away (or possibly destroy) the undead and less powerful demons and devils |

| | | |
|---|---------------------------|--|
| Character Name: Gazlix the Green | |  DEMON'S EYE Player Character Sheet for CAFCON 2019 www.cafconrpg.net |
| Class: Magic-User | Level: 11 | |
| Race: Human | Alignment: Neutral | |
| Vision: Normal | Detections: None | |
| Racial Bonus: None | | |

| ABILITIES | | | | | | | | | | SAVING THROWS | |
|------------|-----------|----------------------------|----|-----------------------|----|------------|----------------------|----------------------|-----|--------------------------------|-----------|
| STR | 4 | HIT ADJ | -2 | DMG ADJ | -1 | OPEN DOORS | 1 | Bend Bars/Lift Gates | 0% | Paralysis/Poison/Death | 11 |
| INT | 18 | MIN SPELLS/LEVEL | | 9 | | | MAX SPELLS/LVL | | 18 | Petrification/Polymorph | 9 |
| WIS | 15 | MENTAL SAVES | +1 | | | | | | | Rod/Staff/Wand | 7 |
| DEX | 18 | REACTION/ATTACK ADJUSTMENT | | +3 | | | DEFENSIVE ADJUSTMENT | | -4 | Breath Weapon | 11 |
| CON | 11 | HP ADJ | 0 | SYSTEM SHOCK SURVIVAL | | 70% | RESURRECT SURVIVAL | | 75% | Spells | 8 |
| CHA | 9 | | | | | | | | | | |

| | | | |
|-------------------|--------------------|---|--|
| HIT POINTS | ARMOR CLASS | ARMOR WORN | MODIFIERS |
| 33+3 | 1 | +3 Ring of Protection, Staff of Sorcery | Shieldless AC: 1 Back AC: 1 |

| WEAPON PROFICIENCIES: Dagger, Staff | | |
|--|------------------------|-------|
| WEAPON | BASE DAMAGE (S or M/L) | NOTES |
| Dagger +2 | 1-4/1-3 | |
| Staff of Sorcery (+2 staff) | 1-6/1-6 | |

| MAGIC ITEMS | EQUIPMENT |
|--|--|
| <p>Staff of Sorcery: [22 charges] This potent staff contains many spell powers and functions so as to be a powerful arsenal in a single device. The staff can cast the following spells at 12th level ability (each spell can be used once per round):</p> <ul style="list-style-type: none"> 1 charge: <i>Affect Normal Fires, Dancing Lights, Enlarge, Mending, Shield</i> 2 charges: <i>Fear, Gust of Wind, Protection from Normal Missiles, Water Breathing</i> 3 charges: <i>Fire Shield, Lightning Bolt, Minor Globe of Invulnerability</i> <p>Furthermore, when held, the staff grants the following bonuses and powers:</p> <ul style="list-style-type: none"> +2 weapons to hit/damage in melee combat +2 bonus towards armor class +2 bonus to all saving throws <p>Once all of the charges are expended, the item depowers into a normal staff until recharged.</p> <p>Scroll (Magic User – 14th level): <i>Airy Water, Dig, Disintegrate, Hold Monster, Monster Summoning III, Shatter, Teleport</i></p> <p>Dagger +2</p> <p>Ring of Protection +3: +3 towards armor class and saving throws</p> <p>Potion of Extra Healing: [3 doses] Restores 3d8 +3 (or 1d8 for a 3rd of the potion)</p> | Metal scroll case Belt pouch (small) Cloak Boots (high, soft) Cap (wizard's cap) Robe Bullseye Lantern |

| MEMORIZED SPELLS | |
|------------------|---|
| LEVEL 1 | <i>Detect Magic, Identify, Magic Missile (2)</i> |
| LEVEL 2 | <i>Invisibility, Knock, Strength, Web</i> |
| LEVEL 3 | <i>Dispel Magic, Fireball, Haste, Slow</i> |
| LEVEL 4 | <i>Dimension Door, Polymorph Self, Wizard Eye</i> |
| LEVEL 5 | <i>Cone of Cold, Telekinesis, Wall of Force</i> |

| FAMILIAR | |
|-------------|--|
| CROW | AC: 7, HP: 3, affords "excellent vision" (refer to page 66 of the <i>Players Handbook</i> . When within 12' of its master, the Familiar's HP is added to Gazlix's (if slain, then Gazlix permanently loses double that number of HP). 100% faithful. |

| | | |
|---|-------------------------------|--|
| Character Name: Larrias the Lawful | |  Player Character Sheet for CAFCON 2019 www.cafconrpg.net |
| Class: Cleric | Level: 9 | |
| Race: Human | Alignment: Lawful Good | |
| Vision: Normal | Detections: None | |
| Racial Bonus: None | | |

| ABILITIES | | | | | | | | | | SAVING THROWS | | | |
|------------|-----------|----------------------------|------|-----------------------|------|--------------|----------------------------|----------------------|-----|-------------------------------|-----------|--------------------------------|-----------|
| STR | 15 | HIT ADJ | None | DMG ADJ | None | OPEN DOORS | 1-2 | Bend Bars/Lift Gates | 7% | Paralysis/Poison/Death | 7 | | |
| INT | 13 | | | | | | | | | | | Petrification/Polymorph | 10 |
| WIS | 18 | MENTAL SAVES | +4 | SPELL FAILURE | 0% | BONUS SPELLS | 2x1st, 2x2nd, 1x3rd, 1x4th | | | Rod/Staff/Wand | 11 | | |
| DEX | 17 | REACTION/ATTACK ADJUSTMENT | | +2 | | | DEFENSIVE ADJUSTMENT | | -3 | Breath Weapon | 13 | | |
| CON | 14 | HP ADJ | None | SYSTEM SHOCK SURVIVAL | | | 88% | RESURRECT SURVIVAL | 92% | Spells | 12 | | |
| CHA | 15 | | | | | | | | | | | | |

| | | | |
|------------|-------------|---|--------------------------------------|
| HIT POINTS | ARMOR CLASS | ARMOR WORN | MODIFIERS |
| 49 | 0 | +1 Splint mail, helm (small), boots (low, hard) | Shieldless AC: 0 Back AC: 0 |

WEAPON PROFICIENCIES: Flail, Club, Hammer, Staff

| WEAPON | BASE DAMAGE (S or M/L) | NOTES |
|---|------------------------|--|
| <i>Thean's Guardian</i> (Flail +1/+2 vs Undead) | 2-7/2-8 | Footman's flail |
| <i>Club of Righteous Bludgeoning</i> (Club +1) | 1-6/1-3 | Natural 20 to hit = victim must save vs Rod/Wand/Staff or lose 1 point of INT. |

| MAGIC ITEMS | EQUIPMENT |
|---|---|
| <p><i>Thean's Guardian</i>: +1 Flail (+2 vs Undead). When fighting undead, the weapons has the following powers:</p> <ul style="list-style-type: none"> The spiked-ball at the end of the flail glow's green (equal to a torch) when within 30' of any undead. Acts as a holy symbol and permits the wielder to turn undead as if 2 levels higher. | Iron holy symbol Large belt pouch 6 vials Holy water Silver scroll case Bone scroll case 1 oil flask 10-foot pole |
| <p><i>Club of Righteous Bludgeoning</i>: +1 club. On a natural 20 'to hit', the victim must save vs Rod/Staff/Wand or lose 1 point of INT.</p> | |
| <p><i>Potion of Diminution</i>: [1 dose] Can shrink up to 5% of normal size. Lasts 6 turns + 2-5 turns (d4+1)</p> | |
| <p><i>Scroll (Protection from Magic)</i>: Invokes an invisible anti-magic globe in a 5' radius around the reader. The globe moves with its invoker. Prevents magic from passing into or out of its confines. Any magical item which touches the globe must be saved for with a 50% likelihood of the object being drained of all magic from the power of the globe. The protection lasts for 5-30 (5d6) rounds.</p> | |
| <p><i>Scroll (Cleric – 17th level)</i>: Heal, Holy Word, Part Water, Resurrection</p> | |
| <p><i>Scroll (Cleric – 11th level)</i>: Create Water, Cure Light Wounds, Cure Serious Wounds, Lower Water, Raise Dead</p> | |
| +1 Splint Mail | |

| MEMORIZED SPELLS | | |
|------------------|---|---|
| LEVEL 1 | 6 | <i>Bless, Cure Light Wounds [2], Detect Evil, Protection from Evil, Sanctuary</i> |
| LEVEL 2 | 6 | <i>Augury, Chant, Find Traps, Know Alignment, Silence 15' Radius, Slow Poison</i> |
| LEVEL 3 | 4 | <i>Cure Blindness, Dispel Magic, Prayer, Remove Curse</i> |
| LEVEL 4 | 3 | <i>Cure Serious Wounds, Divination, Neutralize Poison</i> |
| LEVEL 5 | 1 | <i>Commune</i> |

| CLASS ABILITIES |
|--|
| Undead turning: The ability to turn away (or possibly destroy) the undead and less powerful demons and devils |

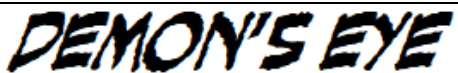
| | | | |
|--|-------------------------------|---|--|
| Character Name: Pritchamik the Wily | |  Player Character Sheet for CAFCON 2019 www.cafconrpg.net | |
| Class: Assassin (posing as a Thief) | Level: 9 | | |
| Race: Half-Orc | Alignment: Lawful Evil | | |
| Vision: Infravision 60' | Detections: None | | |
| Racial Bonus: +1 to STR, +1 to CON, -2 to CHA | | | |

| ABILITIES | | | | | | | | | | SAVING THROWS | |
|-----------|----|----------------------------|------|-----------------------|----|----------------------|--------------------|--------------------------|------|-------------------------|----|
| STR | 17 | HIT ADJ | +1 | DMG ADJ | +1 | OPEN DOORS | 1-3 | Bend Bars/ Lift Gates | 13% | Paralysis/Poison/Death | 11 |
| INT | 16 | | | | | | | | | Petrification/Polymorph | 10 |
| WIS | 14 | MENTAL SAVES | None | | | | | | | Rod/Staff/Wand | 10 |
| DEX | 14 | REACTION/ATTACK ADJUSTMENT | | None | | DEFENSIVE ADJUSTMENT | | None | | Breath Weapon | 14 |
| CON | 19 | HP ADJ | +3 | SYSTEM SHOCK SURVIVAL | | 100% | RESURRECT SURVIVAL | | 100% | Spells | 11 |
| CHA | 6 | | | | | | | | | | |

| | | | |
|------------|-------------|------------------|--------------------------------|
| HIT POINTS | ARMOR CLASS | ARMOR WORN | MODIFIERS |
| 59 | 7 | +1 Leather Armor | Shieldless AC: 7 Back AC: 7 |

WEAPON PROFICIENCIES: Short Sword, Long Sword, Dagger, Short Bow, Jo Stick

| WEAPON | BASE DAMAGE (S or M/L) | NOTES |
|-----------------------------|------------------------|---|
| Dagger of Venom (+1 dagger) | 1-4/1-3 + Poison | Hit on a score of 20 injects fatal poison (save applicable) |
| Short Sword +2 | 1-6/1-8 | |
| Short Bow | 1-6/1-6 (arrow) | Rate of fire = 2 arrows/round |

| MAGIC ITEMS | EQUIPMENT |
|---|--|
| Dagger of Venom: +1 dagger. Hilt can hold 6 doses poison. (can be refilled). Hit on a score of 20 injects fatal poison into opponent unless a saving throw vs poison is successful. | Thieves' picks & tools 3 Oil Flasks Small belt pouch Tinder box + flint/steel 6 torches Metal flask Quiver |
| Ring of Invisibility: The wearer can become invisible at will (as per the magic-user spell <i>Invisibility</i>). | |
| Bag of Holding: Weight=15 pounds, weight limit=500 pounds, volume limit=70 cubic feet. | |
| Amulet of Proof Against Detection and Location: Prevents all divination and mental/magical location and detection (including <i>clairaudience</i> , <i>clairvoyance</i> , <i>ESP</i> , <i>telepathy</i> , <i>crystal ball</i> , or any other scrying devices). No aura is discernable on the wearer. | |
| Poison: [8 doses] Injection-type (introduced through break in skin). Potent. Save -4 or die. | |
| Poison: [4 vials] Gas-type (in glass vials; disperses 20' radius cloud; persists x 1 turn; odorless.). Save -2 or die. | |
| Necklace of Adaptation: Ignore gasses of all sorts which affect creatures through respiration, breathe underwater, or even exist in airless space for up to 7 days. | |
| Quiver: Contains the following: +2 Arrows [5] +1 Arrows [11] Normal Arrows [18] | |
| +1 Leather Armor | +2 Short Sword |

| CLASS ABILITIES |
|---|
| Thieves Abilities (level 7 ability + Half-Orc modifiers): <ul style="list-style-type: none"> ▪ Pick Pockets: 55% ▪ Open Locks: 57% ▪ Find/Remove Traps: 55% ▪ Move Silently: 55% ▪ Hide in Shadows: 43% ▪ Hear Noise: 30% ▪ Climb Walls: 99% ▪ Read Languages: 25% |
| Backstabbing: Striking from behind. Damage per hit is TRIPLE DAMAGE. Striking by surprise from behind also increase the hit probability by 20% (+4 on the assassin's 'to hit' die roll). |
| Assassination: If an assassin surprises the victim, they may attack on the ASSASSINATION TABLE. This gives a roughly 50% chance of immediately killing the victim; and if this fails, normal damage according to the weapon type and strength ability modifiers. If a poisoned weapon is used, the victim must roll a saving throw. The assassin decides which attack mode will be used: assassination, back stabbing, or normal melee combat. |
| Alignment Languages: Chaotic Good, Chaotic Neutral |
| Disguise: Can disguise to appear human, semi-human, or humanoid creature of either sex. Can lower height by 2-3 inches or raise it by 4-5 inches. Can appear slimmer or heavier. Can appear as virtually any class of character. Refer to page 29 of <i>Players Handbook</i> for chances of discovery (and associated modifiers). |

| | | |
|--|--------------------------------|---|
| Character Name: Redem Ynohtna | |  Player Character Sheet for CAFCON 2019 www.cafconrpg.net |
| Class: Fighter | Level: 10 | |
| Race: Elf | Alignment: Chaotic Good | |
| Vision: Infravision 60' | | |
| Detections: Secret doors: 1-in-6 chance of detection within 10ft of passing or 2-in-6 if actively searching); Concealed portals: 3-in-6 chance. | | |
| Racial Bonus: +1 "to hit" with short/long sword or bow; 90% resistant to <i>sleep</i> and <i>charm</i> spells; +1 to DEX, -1 to CON. | | |

| ABILITIES | | | | | | | | | | SAVING THROWS | | | | | |
|------------|-----------|----------------------------|--------|-----------------------|----|------------|----------------------|----------------------|-----|-------------------------------|----------|--------------------------------|-----------|-----------------------|-----------|
| STR | 16 | HIT ADJ | Normal | DMG ADJ | +1 | OPEN DOORS | 1-3 | Bend Bars/Lift Gates | 10% | Paralysis/Poison/Death | 8 | | | | |
| INT | 16 | | | | | | | | | | | Petrification/Polymorph | 9 | | |
| WIS | 11 | MENTAL SAVES | None | | | | | | | | | | | Rod/Staff/Wand | 10 |
| DEX | 19 | REACTION/ATTACK ADJUSTMENT | | +4 | | | DEFENSIVE ADJUSTMENT | | -5 | | | Breath Weapon | 9 | | |
| CON | 15 | HP ADJ | +1 | SYSTEM SHOCK SURVIVAL | | 91% | RESURRECT SURVIVAL | | 94% | | | Spells | 11 | | |
| CHA | 15 | | | | | | | | | | | | | | |

| | | | |
|-------------------|--------------------|--|----------------------------------|
| HIT POINTS | ARMOR CLASS | ARMOR WORN | MODIFIERS |
| 88 | -5 | Elven Chain Mail +5, Slippers of Spider Climbing | Shieldless AC: -5 Back AC: -5 |

| WEAPON PROFICIENCIES: Long bow, Short bow, Scimitar, Short sword, Dagger, Javelin, Throwing axe | | |
|--|------------------------|---|
| WEAPON | BASE DAMAGE (S or M/L) | NOTES |
| <i>Eibbid's Longbow</i> (+1 long bow) | 1-6/1-6 (arrow) | Rate of fire = 4 arrows per round |
| <i>Niugnep's Bite</i> (+2 scimitar) | 1-8/1-8 | Successful hit = Victim must save vs Death or lose an additional 1d4 hp for 1d4 rounds |
| <i>Dagger +2</i> | 1-4/1-3 | |
| <i>Throwing Axe +1</i> | 1-6/1-4 | Will return to thrower if target is missed. Takes 1 melee round to return. |
| <i>Javelin of Piercing</i> (7) | 7-12 | +6 to hit, good for 1 throw, can fly horizontally/vertically or any combination to the full extent of its range |

| MAGIC ITEMS | EQUIPMENT |
|--|--|
| <i>Eibbid's Longbow</i> : +1 longbow (both 'to hit' and 'to damage'). When in the hands of an Elf, the rate of fire is doubled from 2 arrows/round to 4 arrows/round. | Leather backpack 3 Oil flasks Tinder box + flint 4 torches Silver mirror Quiver |
| <i>Niugnep's Bite</i> : +2 scimitar. In addition to base damage dealt by the blade, victims hit by <i>Niugnep's Bite</i> must save vs Death or lose an additional 1d4 hit points per round for 1d4 rounds. | |
| <i>Slippers of Spider Climbing</i> : Allows the wearer to walk at 6" rate on curved or vertical surfaces such as walls or cliffs. Upside down movement is possible. Extremely slippery surfaces such as ice or oiled surfaces make these slippers useless. | |
| <i>Elven Chain Mail +5</i> : Weightless, incredibly durable, but thin as cloth. Does not add to encumbrance or bulk. | |
| <i>Throwing Axe +1</i> : Will return to thrower if target if missed. Takes 1 melee round to return. | |
| <i>Potion of Extra Healing</i> : [2 doses] Restores 3d8 +3 (or 1d8 for a 3rd of the potion) | |
| <i>Javelin of Piercing</i> : [7 javelins] +6 to hit, good for 1 throw, can fly horizontally/vertically or any combination to the full extent of its range | |
| <i>+2 Dagger</i> | |
| <i>Quiver</i> : Contains the following arrows: Arrow of Demon Slaying (+3) [1] | |
| +3 Arrows [4] +2 Arrows [8] +1 Arrows [16] Normal Arrows [20] | |

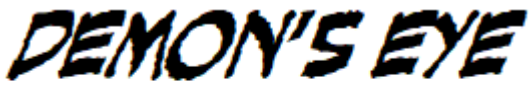
| | | |
|-----------------|------------|--|
| Character Name: | |  Player Character Sheet for CAFCON 2019 www.cafconrpg.net |
| Class: | Level: | |
| Race: | Alignment: | |
| Vision: | | |
| Detections: | | |
| Racial Bonus: | | |

| ABILITIES | | | | | | | SAVING THROWS | | |
|-----------|----------------------------|-----------------------|------------|--------------------------|--|--|----------------------------|--|--|
| STR | HIT ADJ | DMG ADJ | OPEN DOORS | Bend Bars/ Lift Gates | | | Paralysis / Poison / Death | | |
| INT | MIN SPELLS/LEVEL | | | MAX SPELLS/LVL | | | Petrification/Polymorph | | |
| WIS | MENTAL SAVES | SPELL FAILURE | | BONUS SPELLS | | | Rod, Staff, Wand | | |
| DEX | REACTION/ATTACK ADJUSTMENT | | | DEFENSIVE ADJUSTMENT | | | Breath Weapon | | |
| CON | HP ADJ | SYSTEM SHOCK SURVIVAL | | RESURRECT SURVIVAL | | | Spells | | |
| CHA | | | | | | | | | |

| | | | |
|------------|-------------|----------------|-------------|
| HIT POINTS | ARMOR CLASS | Shieldless AC: | Armor Worn: |
| | | Back AC: | |

| WEAPON PROFICIENCIES: | | |
|-----------------------|--------|-------|
| WEAPON | DAMAGE | NOTES |
| | | |
| | | |
| | | |
| | | |

| MAGIC ITEMS | EQUIPMENT |
|-------------|-----------|
| | |
| | |
| | |
| | |

| MEMORIZED SPELLS | |
|------------------|--|
| LEVEL 1 | |
| LEVEL 2 | |
| LEVEL 3 | |
| LEVEL 4 | |
| LEVEL 5 | |

Dungeon Master's Notes

