



Operation Unfathomable

Player's Guide

Jason Sholtis





READ THIS BEFORE ENTERING

In this slim volume you'll find:

- **Unfathomable Comics!**
 - **Two playable races: Underworld Otter and Woolly Neanderthal**
 - **Two character classes, the Citizen lich and the Underworld Ranger**
 - **Unsavory new spells**
 - **Weird new items**
 - **Background materials**
 - **A partial, probably faulty map of the Underworld**
 - **Rumors and semi-helpful tips**
-



HYDRA
COOPERATIVE
hydraco-op.com

**OPERATION
UNFATHOMABLE**

OPERATION UNFATHOMABLE



CREDITS

By Jason Sholtis

Additional material by Robert Parker, Paolo Greco,
Bobby Martin

Illustrations by Jason Sholtis

Cover design by Trey Causey

Players' Map by Karl Stjernberg

Layout and design by Regina Shelley

Copyright 2018 Jason Sholtis

Published by Hydra Cooperative

<http://hydraco-op.com/>

Swords & Wizardry, S&W, and Mythmere Games are trademarks of Matthew J. Finch,™ and that Hydra Cooperative and Jason Sholtis are not affiliated with Matthew J. Finch, Mythmere Games™, or Frog God Games

OPERATION UNFATHOMABLE





INTRODUCTION

WELCOME, PLAYERS!

In this slim volume you'll find two character classes, a pair of playable races, an assortment of spells PCs might come across over the course of play (or that your DM might allow from the outset, depending upon their policies), background information pertaining to the initial Operation Unfathomable scenario, Underworld information survival tips, and a players' map.

But first, check out this short comic set in the Underworld. The first two pages were created in homage to the old TSR-era D&D ads that ran in American comic books starting in 1981 (I loved them as a kid, sometimes more than the comics in which they appeared), then the story continues for six more pages calculated to convey the feel of the Operation Unfathomable setting in the most painless way possible.

OPERATION UNFATHOMABLE

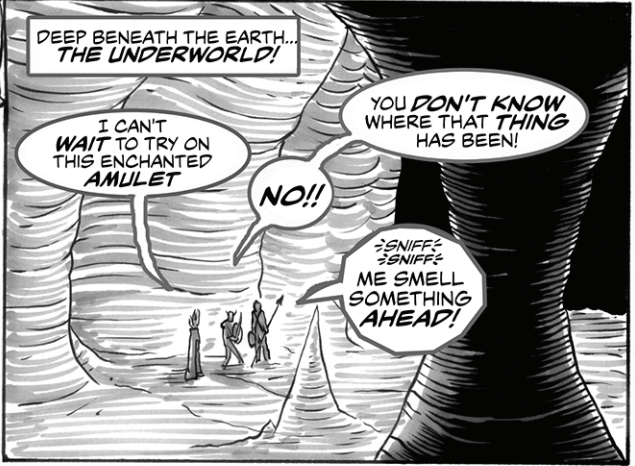

TO BE CONTINUED
IN
OPERATION UNFATHOMABLE

CHAPTER TWO!

An **OPERATION UNFATHOMABLE** CHAPTER 2 Adventure

DUE TO THE PROPERTIES OF A MYSTERIOUS ENCHANTED AMULET, ULIGI'S DISEMBODIED HEAD FLOATS FREELY AROUND THE UNDERWORLD...

WE WATCH BODY, ME GUESS.
WONDERFUL! I SHALL SCOUT AHEAD.

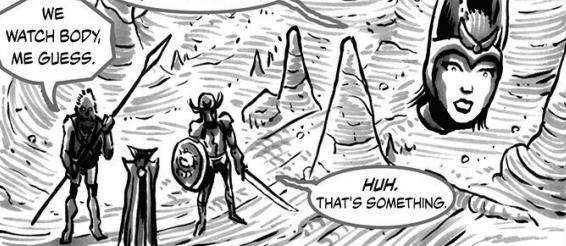

SOON..

HEAVY FUNGAL GROWTH AHEAD. KEEP BACK, I'LL CHECK IT OUT.



GREETINGS, HEAD-BEING! YOU AND YOUR FRIENDS HAVE NO NEED TO FEAR! WE ARE SCIENCE FUNGOID RESEARCHERS AND SEEK YOUR PARTICIPATION IN AN EXCITING EXPERIMENT!



JUST SIGN THIS WAIVER AND NON-DISCLOSURE AGREEMENT AND WE'LL GET STARTED!

SORRY BUT I DON'T SEE THAT HAPPENING, FUNGOID.



HUMANOID! SO CHARMING! PLEASE, YOU'LL BE PERFECT SUBJECTS.

NO. I BID YOU GOOD DAY.

BUT--

I SAID GOOD DAY!

WE GO BACK OTHER WAY?



REALLY?

ABSOLUTELY. THOSE SCIENCE FUNGOIDS ARE EVIL INCARNATE!

LOOK, IT'S TIME I LEVELED WITH YOU TWO ABOUT MY PURPOSE DOWN HERE...



YOU SEE...

ZOOOPP!

SAY... WHAT'S THAT RED GLOW?



WHA?

OPERATION UNFATHOMABLE
CHAPTER THREE!

OPERATION UNFATHOMABLE

An OPERATION UNFATHOMABLE Adventure

HIRELINGS NEVER LAST
LONG IN THE UNDERWORLD.

LIGHTNING BOLT,
NOW!!

WHERE THE HELL
IS SHE?

HER GONE!

FIGHT
NOW!

THE WARRIOR YURL AND GLAAK,
HIS WOOLLY NEANDERTHAL
HENCHMAN, WERE A CUT ABOVE
THE TYPICAL SCUM HANGING
AROUND FORT ENTERPRISE...

EXPENSIVE, TOO.

WELL, THEY GOT ME THIS FAR.

GLEEEFARRGH!!

THE SHAGGY CAVEMAN WAS LOYAL LIKE A
FAITHFUL HOUND. ALMOST NOBLE...
FOR A BESTIAL SUBHUMAN.

OH
NO!

ME KILL!

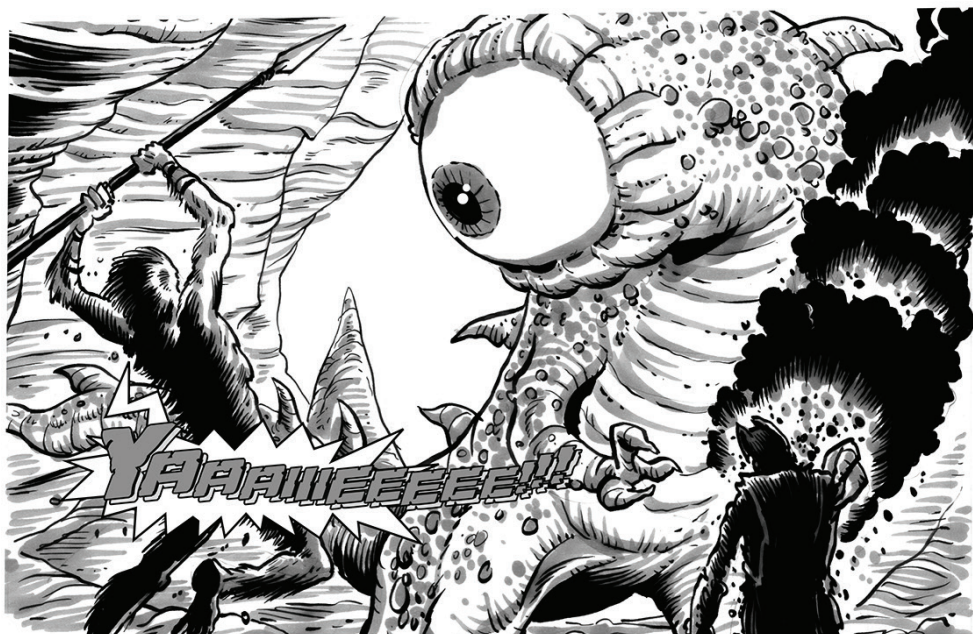

OPERATION UNFATHOMABLE

I AM **ULISI**, SORCERER OF THE 8TH RANK, **UNAFFILIATED**.

IF THERE'S **ANYTHING** I'VE LEARNED OVER THE **YEARS...**

IT'S THAT IT PAYS TO KNOW WHEN TO BE **INVISIBLE**.

THE **TYRANNOCLOPS** MOVED OFF... BUT IN **EXACTLY** THE DIRECTION I **DIDN'T** WANT IT TO GO.

USING THE **AMULET OF ADVANTAGEOUS AUTO-DECAPITATION**, I FOLLOWED EFFORTLESSLY, UNENCUMBERED BY MY **EXHAUSTED** BODY.

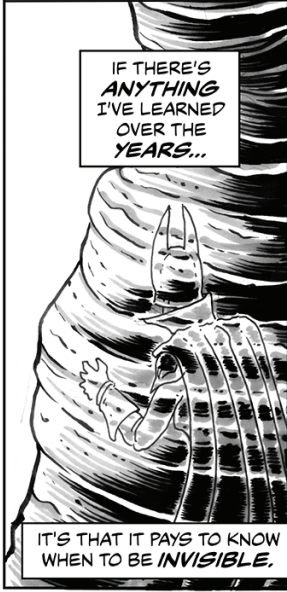

AT LONG LAST I WOULD KNOW THE **SECRETS** OF **KA**, CITY OF THE **EXTINCT** **BEETLE** CIVILIZATION!

OPERATION UNFATHOMABLE

I BEHELD MANY WONDERS
AS I SURVEYED KA'S
PALEOGEAN BYWAYS...

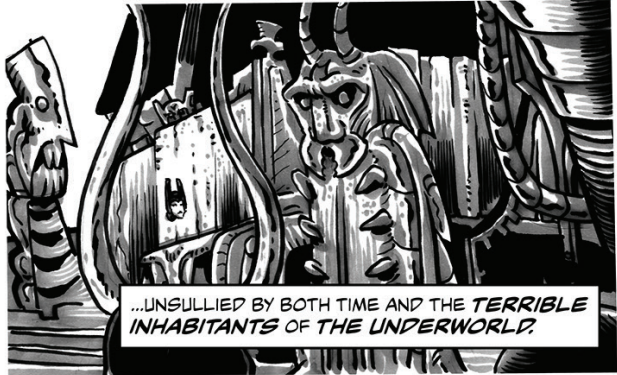

...UNSULLIED BY BOTH TIME AND THE TERRIBLE
INHABITANTS OF THE UNDERWORLD?

MANY TIMES, I HAD NO INKLING
OF WHAT WAS BEFORE ME.



WHEN I REACHED THE UNIVERSITY DISTRICT, I SPOKE
MY FINAL SPELL OF AUGURY.

I SAW **PRIMAL CHAOS** SEETHING AT THE **CENTER OF THE UNIVERSE**, SLOUGHING OFF THE STUFF OF **WORLDS AND STARS** IN ITS **SLOW DECAY**.



I WITNESSED THE **BETLES** IN THEIR EARLIEST EPOCHS OF **SWORDS AND SORCERY!**

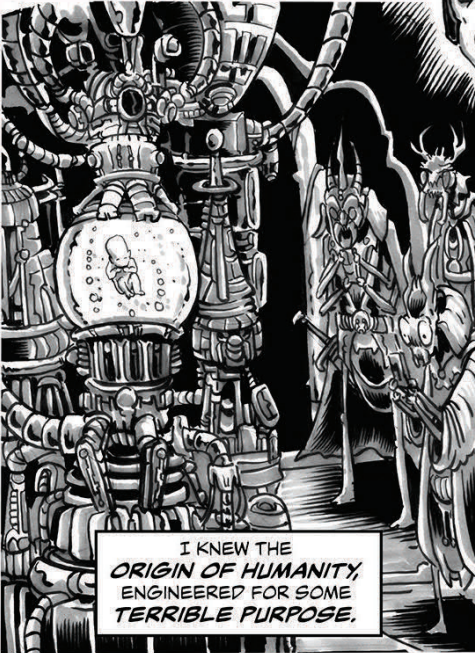

I KNEW THE **ORIGIN OF HUMANITY**, ENGINEERED FOR SOME **TERRIBLE PURPOSE**.



AND I WATCHED THE **WORM BROTHERS** IN THEIR **FRATRICIDAL STRUGGLE**, WHEN MIGHTY **SHAGGATH** DEVoured **KA**.

OPERATION UNFATHOMABLE

SHAKEN, I DEPARTED TO RECORD THESE REVELATIONS BEFORE THEY FADED FROM MY MIND.



IT WAS ONLY THEN THAT I REMEMBERED MY BODY.



BLIND ANTLER MEN!!



GAK!



END?

UNDERWORLD OTTERS

These beings descended from giant river otters and were genetically manipulated to grow to a maximum height of 6', develop fully opposable thumbs, and heighten their maximum intelligence to human-like levels. Underworld otters speak Underworld common with moist, growly voices and are equally comfortable ambulating in bipedal and quadrupedal modes. They have no material culture.

Generations ago, the magic user responsible for their creation (Zaracanth, a noted Underworld celebrity) released the otters into the Black Ooze river valley, and callously washed his hands of all responsibility for their fate. The otters quickly adapted to their environment, dwelling in shore caverns and subsisting upon various river oozes and young basking sharks native to the Black Ooze river. Otters, strict carnivores, can and do enjoy the flesh of most animals, including those creatures warped by Chaos and those in an advanced state of decomposition.

Underworld otter PCs may choose from the fighter or thief (otter thieves receive 1d8 hp at first level, 1d4 for subsequent) classes but can only begin to use human-style weaponry after attaining level 2, provided a patient human instructor is available. Underworld otter fighters choose a single human weapon type for each level (ex. sword at level 2, bow at level 3), thieves may learn one at level two (chosen from the thief list) and one every second level thereafter.

Underworld otters produce an oil in their skin and coats that protects them from the digestive attacks of oozes, slimes, jellies, and puddings. When in combat with these creatures, the black otter has an effective AC of 0. Black otter urine is a powerful ooze repellent.



- Strength: 6+2d6
- Dexterity: 12+1d6
- Wisdom: 6+ 1d6
- (Natural AC: 6 (modified by Dex bonus)
- Attacks: 2 claws (1d3) or bite (1d6)
- Starting monies and equipment: none
- Otters can only wear custom made armor (exorbitant cost determined by DM)

SAVE VERSUS FUN

Though deadly fighters, otters retain the fun-loving frivolity of their earthly analogs. An otter should never miss an opportunity to propel itself down an Underworld waterfall, douse itself in the foulest smelling swamp sloughs, or sample the flavor of monster meats in advanced states of decay. However, when such a course of action would obviously imperil itself or its comrades (in the middle of combat or when pursued by dangerous enemies, for example), the player must make a saving throw to avoid shirking its duty and indulging its powerful play impulses. DMs should impose this roll at their discretion and never fail to lavish approbations upon the player that reminds them of this potentially hazardous characteristic.

WOOLLY NEANDERTHAL

Native to the chilly northern lands of Mastodonia, the woolly Neanderthals abide in small, physically isolated clans, often making their homes in and among great piles of huge glacially deposited stones. They subsist upon a variety of mastodon meats and have refined the arts of drying, smoking, curing, and barbecuing this sole source of nutrition to a high level of sophistication. Gourmands from civilization have been known to risk travel through the savage provinces to feast among the Woollies.

Their material culture remains at a Stone Age level, despite (generally unwanted) contact with humans and other cultures.

Woolly Neanderthals average around 6 ½ feet in height, and weigh in at an average 250 lbs of lean, wiry muscle. They are completely hirsute, and eschew clothing beyond mastodon leather action harnesses.

These mighty hominids are typically shy and retiring, and in general go to great lengths to avoid encounters with human beings. Nevertheless, unusual individuals sometimes join adventuring parties and are prone to forming strong, Chewbacca-like bonds with single human beings.



WOOLY NEANDERTHAL

Woolly Neanderthals PCs may become fighters with the following racial adjustments:

- Roll 2d6+6 for constitution
- Roll 1d6+12 for strength
- Roll 2d6+1 for intelligence
- Starting money: 0d6 x 0
- Starting equipment: Stone-tipped axe and spear (break on an attack roll of 1), water bladder, 1d6 weeks worth of mammoth-jerky, stone knife
- Unarmored woolly neanderthals have a natural AC of 6 (adjusted by Dex bonus) owing to their thick, matted fur and thick skins.

Woollies possess an animal cunning that belies their generally low level of human-style intellect. They aren't great with abstract concepts, but they aren't complete idiots. Even at maximum intelligence, woolly neanderthals speak in an old school Tarzan/Frankensteen/Tonto style dialect.

Due to their exceptional size, both armor and weapons cost 50% more than normal from human purveyors. In the wild, woolly neanderthals have not developed metallurgy and resort to stone age weapons and leather armor.

DM option: In my campaign, I do not employ level limits for these demihumans, but if so desired I suggest using dwarf limits for woollies and halfling limits for otters.

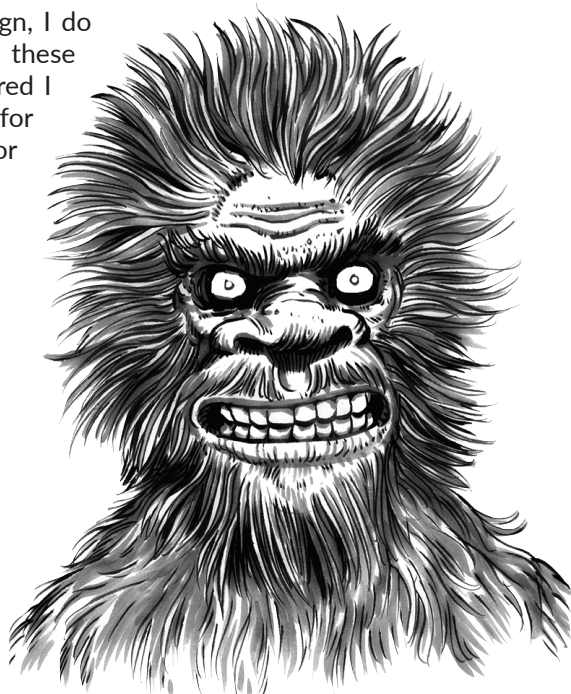

NEW CLASSES

CITIZEN LICH

- Prime Attribute: Intelligence 13+ (5% XP bonus)
- Hit Dice: 1 hp at first level, d4-1 thereafter
- Fights: As Magic User
- Saves: As Magic User (+2 bonus to roll against spells, Chaos exposure)
- Armor/Shield permitted: none
- Weapons permitted: dagger, staff
- Race: Humans only
- Minimum stats required: Int 13

In civilized areas of Planet Uluros, where magocracy remains the predominant form of government, magic-users frequently attempt to extend their lives by making a transition to an undead condition. These attempts succeed often enough, but more commonly end in the magic-user's destruction, or, more rarely, in a transformation to a lesser form of lich called a citizen lich. As the name implies, citizen liches are recognized members of their communities (though true liches regard them as second class).

The citizen lich enjoys a limited immortality (See Hard to Kill, below) at the expense of whatever physical beauty they enjoyed in life and, most distressingly, their previous mastery of magic. While their features shrivel into hideousness, citizen liches retain their memories and personalities, but must completely retrain themselves in the use of enchantments, starting again at level 1. To add insult to injury, citizen liches also must completely restore themselves to material wealth, having liquidated all assets in their attempt at true lichhood.

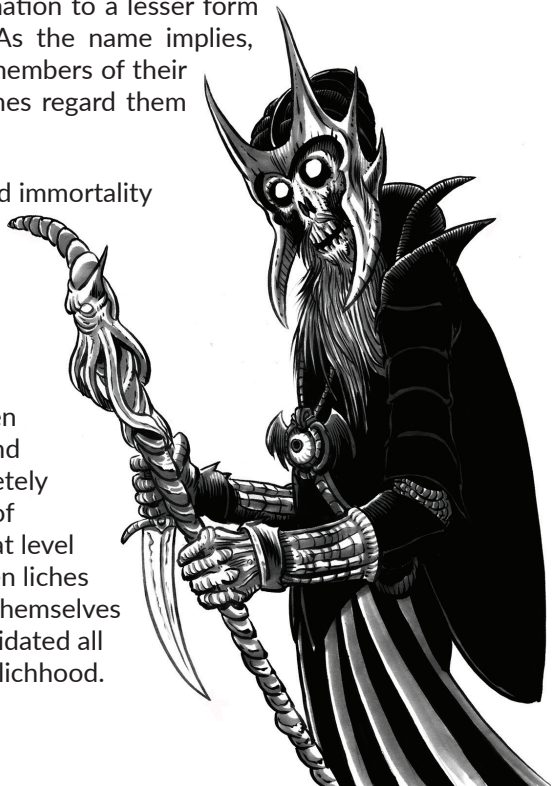

Similar in most respects to the magic-user class, citizen lichs differ in the following ways:

UNDEAD (QUASI-LIVING)

In civilized areas, citizen lichs enjoy the same rights (or lack thereof) and status as most humans. Barbarians (and the near-human hominids native to Mastodonia) lack this basic decency, however, and many will not hesitate to express their disdain for lichs of any stripe. The wise citizen lich makes a policy of disguising their features when abroad in remote wildernesses.

Citizen lichs may be turned by a cleric equal to their level and are affected by anti-undead weapons, items, and spells.

HARD TO KILL (PERMANENTLY)

Citizen lichs lack the phylacteries so prevalent among traditional lichs, but the entirety of their physical bodies, wracked by the painfully eldritch rites of their creation, serve a similar purpose.

Due to the total systemic meltdown triggered in the transition from a living to an undead condition the citizen lich begins with only 1 hp. When reduced to 0 or fewer hit points, the citizen lich collapses into a lifeless heap. However, citizen lichs can only be permanently destroyed by forces like fire, acid, disintegration, “D” results on the Clerical Turning Table, holy water/weapons, and any other circumstance deemed suitable by the DM. If any part of the lich body remains, it will slowly regenerate back to its full form and strength at the rate of 1 hp/day. The citizen lich may resume normal activities when it returns to 1 hp.

This power of regeneration increases to 2 hp/day at level 6 and to 3 hp/day at level 12. Citizen lichs take damage from magical healing and do not recover additional hit points through rest.

LICH'S DUNGEON

At level 12, the citizen lich earns the title “Lich” (though it remains only nominally similar to the classic monster) and can build a dungeon containing all the strange and terrible accommodations the lich desires. The “Lich” automatically attracts a random assortment of lesser undead to its service, all compelled to loyalty by the Lich’s preternatural anti-charisma.

If it so chooses, the Lich may simply choose to overtake and occupy a previously existing dungeon, provided it sees to the destruction/removal of any denizens.

TRUE LICH

At level 13, ensconced in its fabulous lair, the citizen lich may attempt to attain the status of true lich. To do so, the candidate must research (time and expense to be determined by the DM) and cast the spell Contact Outer Lich. Successfully contacting this singular being will trigger either the caster's instant destruction by *fully automatic fireball* or some equally lethal super-sorcery (a roll of 1-4 on 1d6) or an instant ascension to the desired status (a roll of 5 or 6).

Special Abilities	HD (d4)	Level/Rank	XP
Regeneration 1hp/day spells as per Magic Users	1hp	1	0
	1d4-1	2	2,500
	2d4-2	3	5,000
	3d4-3	4	10,000
Regeneration 2 hp/day	4d4-4	5	20,000
	5d4-5	6	35,000
	6d4-6	7	50,000
	7d4-7	8	75,000
	8d4-8	9	100,000
	9d4-9	10	200,000
Regeneration 3 hp/day	10d4-10	11	300,000
	11d4-11	12	400,000
	+hp	13	600,000

UNDERWORLD RANGER

- Prime Attribute: Constitution 13+ (5% XP bonus)
- Hit Dice: d6
- Fights: As Cleric
- Saves: As Cleric (+2 bonus to roll against Chaos exposure)
- Armor/Shield permitted: any
- Weapons permitted: any
- Race: Humans only
- Minimum stats required: Str 12+, Con 12+

Underworld Rangers begin their training in early childhood after selection by secret agents who carefully monitor institutions of learning, comb poor neighborhoods, and lurk around the playgrounds of the rich. Subjects who score in the exceptional range in a battery of blood tests and Chaosometer readings (to ensure resistance to Underworld corruption) are whisked away from their homes to the nearest training facility.

These secret protectors of humanity wage a perpetual, mostly unseen war against Chaos in the Underworld below the civilized southlands. The Underworld Ranger Service operates independently of any government, keeps watch on known Underworld entrances from subterranean fortifications, maintains demilitarized zones deep into the Underworld, and engages in various operations in response to known and emergent threats.

While Ranger stations dot the semi-pacified southern reaches of the Underworld, there are none known in the area of the Underworld described in the Operation Unfathomable book, though there may well be a secret base or two, at the DM's discretion.

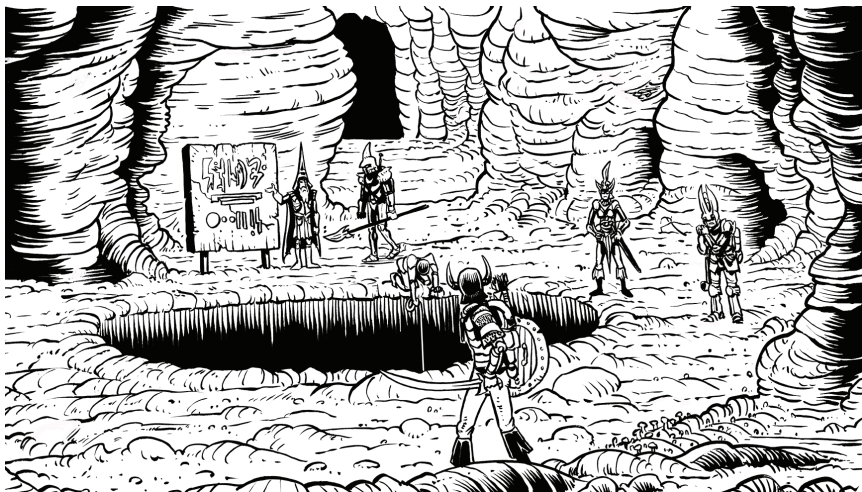



UNDERWORLD RANGER CLASS ABILITIES

UNDERWORLD SURVIVAL

In the Underworld wilderness, Rangers may forage for food and water sources with a 4-in-6 chance of success per day (over the course of an adventuring day, or for a two-hour period of uninterrupted foraging). Successful foraging results are determined by a roll on the table below (provided for color, DMs should adjudicate results based upon local environment):

UNDERWORLD FORAGING SUCCESS

A successful check also indicates a source of potable moisture capable of sustaining the party indefinitely in that location.

d12 Underworld Foraging Success

- | | |
|----|---|
| 1 | 2d4 plump and juicy rats (single meal for up to 8 humans) |
| 2 | 2d6 delicious bats (single meal for up to 12) |
| 3 | d6 blind cave fish (single meal for up to 12) |
| 4 | Several handfuls of glutinous fungi (single meal for party) |
| 5 | Small sack full of edible lizards (party eats for 1 day) |
| 6 | Huge blob of life-sustaining pool algae (party eats for 1d2 days) |
| 7 | 1d3 giant rock snails (party eats for 1d3 days) |
| 8 | A dozen giant lizard eggs (party eats for 1d4 days) |
| 9 | 2d20 giant spider hatchlings (party eats for 1d4 days) |
| 10 | Large sack full of giant insect larvae (party eats for 1d4 days) |
| 11 | Bushel of nutritious lichen (party eats for 2d4 days) |
| 12 | 2d4 cave cephalopods (party eats for 2d4 days) |

UNDERWORLD TRACKING

In the Underworld (and nowhere else), the basic chance for successful tracking (on a day-to-day basis) is 90%, modified by -10% for each day since the tracks were made and modified by -10% (for the entire effort thereafter) for circumstances such as Underworld weather or any other phenomena that could obscure the trail.

SPECIAL EQUIPMENT

Upon completion of basic training, the Underworld Ranger is entrusted with the following special items of equipment:

Badge of Service: Most Underworld sentients (science fungoids, white and gray humanoids, et al.) recognize the Underworld Ranger Service and will avoid hostilities whenever possible. Exceptions abound, specifically the cults and other forces of most known godlings, and these may be provoked into the use of lethal force against the URS where others might be treated with clemency. Alien beings such as the blind antler men do not recognize any human/humanoid authority.

Light-intensifying goggles: grant the user low-light vision as per infravision

Issued at 2nd level:

Service Blade: a short sword enchanted with a permanent anti-Chaos ward that provides a damage bonus equal to +1 against creatures of Chaos (magical beasts, constructs, "demons," etc. at the DM's discretion) and may hit creatures that otherwise require an enchanted weapon of up to +2.

Issued at 3rd level

ZR1 sidearm (see below)

Items lost or destroyed may only be replaced by visiting a ranger station and filling out the requisite paperwork.

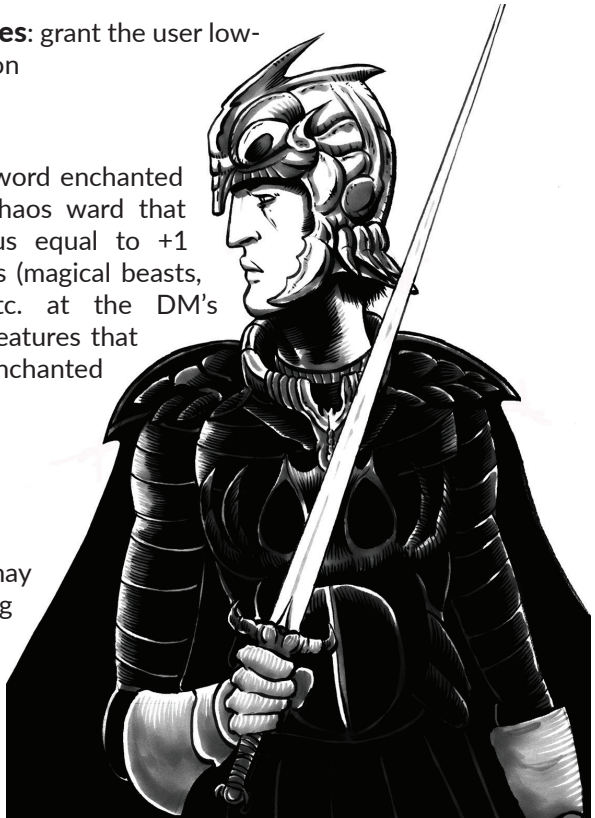

STANDARD ITEMS

Underworld Rangers begin play with any number of mundane dungeoneering items approved by the DM.

MONETARY POLICIES

While members of the URS enjoy any XP earned through the acquisition of treasure, Rangers are obliged to attempt to return acquired wealth to the Ranger Service, keeping only what they may need in the performance of their duties. Paperwork must be filed for such allocations at the nearest URS station.

SAVING THROW BONUS

Underworld Rangers receive a +2 bonus to saving throws against magic spells and other effects directly related to Chaos (such as long-term Underworld exposure, proximity to Primal Chaos, etc. at the DM's discretion)

- Healing balms (restores 1d6+1 HP when applied topically)
- Light-intensifier goggles (see in the dark up to 60')
- ZR1 "Dissuader"
- ZR2 Lightning Gun (plan for use must be submitted for approval, adds 1d4 days to approval process)
- Chaosometer
- Chaos-dampener, man-portable
- Standard-issue potions, DM adjudicates availability which is limited in all cases

REQUISITION ITEM

Starting at level 4 (Ranger), Underworld Rangers receive authority to requisition a number of items equal to their level from the nearest ranger station. The UR must complete a pain-in-the-ass bit of paperwork specifying the items and describing the need for each, then wait for approval for 2–8 days of idleness. Lost or damaged items provoke a formal investigation, additional pain-in-the-ass paperwork, and possible disciplinary action up to and including dismissal from the URS.

RETIREMENT OPTIONS

Unlike most classes, members of the URS do not attract retainers or establish strongholds of any kind. While it is possible for high-ranking Rangers to apply for positions with High Command (handled at the DM's discretion), more commonly Rangers facing retirement will instead outfit themselves for a final descent into the Underworld to smash Chaos in its stinking nest until strength and life fail at last.

SPECIAL EQUIPMENT

Special Equipment	HD (d6)	Level/Rank	XP
LI goggles	1	1/Greenhorn	0
Service blade	2	2/Guard	4,000
ZR 1	3	3/Guard First Class	8,000
Req. Item	4	4/Ranger	16,000
	5	5/Ranger II	32,000
	6	6/RangerIII	64,000
	7	7/Ranger VI	120,000
	8	8/Subcommander	240,000
	9	9/Commander	360,000
	9+2	10/Underwarden	480,000

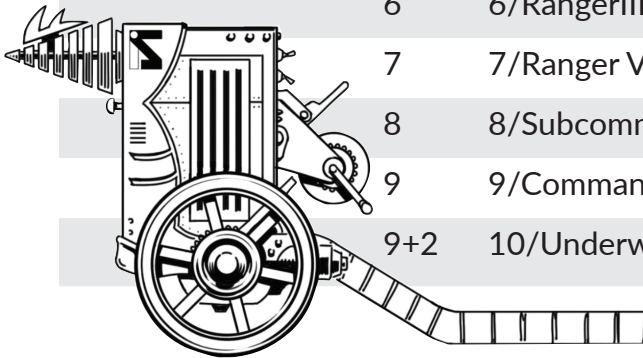

ITEMS AVAILABLE:

For complete item descriptions, see below.

Chaos Dampener, man-portable

These miniature obelisks of an unknown black stone stand 2½ feet high and weigh 50 pounds. When placed and activated by a secret command word, Chaos dampeners reduce the level of Chaos within 120' by a single rank (see Chaosometer) for one hour before requiring a recharge (available only at Underworld Ranger stations).

Chaosometer

Chaosometers measure the amount of Chaos in a 120' radius and indicate this using a needle meter with four basic readings:

1: Typical ambient Chaos

2: Above average but still essentially harmless: could indicate the approach of a Chaos Godling or the proximity of a Chaotic feature of the Underworld (such as a Chaos storm)

3: Dangerous levels: prolonged exposure (more than a turn) provokes a roll on the **Effects of Long-Term Exposure to the Underworld table**

Skull: Lethal levels: evacuate immediately; save vs. death every turn.

Note: Chaos-exposure hazards are beyond the scope of this adventure. PCs who come to possess a chaosometer have essentially granted the DM license to mess with their minds. DMs are encouraged to do so at every opportunity.

Zaracanth Industries ZR-2 Lightning Gun

A bulky, heavy siege weapon on two wheels with a large double-crank apparatus for charging, the lightning gun requires at least 2 human types to move at half their normal movement rate (worse over rough terrain). This field piece, designed for ooze control on the Black Ooze River, discharges a 60' lightning bolt (3d6 damage) once every three rounds if two crewmen are cranking, once every six if only one.

The manufacturer strongly recommends one-hour cooling period following any discharge; attempting to discharge more than twice without cool down voids the warranty and provokes a 1-in-6 chance of destroying the gun in a violent electrical eruption (2d6 damage to all within 30') with each subsequent use.

Anyone attempting to examine the weapon's inner workings by opening the crankcase must make a saving throw or sustain a substantial electric shock (2d6 damage). Only costly research could possibly shed any meaningful light on the mechanisms at play within.

Zaracanth Industries ZR-1 "Dissuader"

The standard field sidearm (sometimes called a "bug zapper") for Underworld Rangers delivers a ball of electricity effective up to 60' (3 settings: 1, 1d3, or 1d6 damage, to-hit roll required). The weapon recharges every other round with vigorous winding of key mechanism. Discharging more than twice before a ten-minute cooling period is highly discouraged and can result in damage to the weapon and operator; subsequent uses provoke a 1-in-6 chance per use of an electrical eruption that destroys the gun and does 1d6 damage to the user.

SPELLS

Magic Missive

Spell Level: Magic-User, 1st level

Range: Unlimited

Duration: Instantaneous

Designed for communication between wizards' towers, this spell enables the caster to unerringly transmit a letter or other document across any distance, so long as the location of the recipient is known (also see reveal location). The letter materializes on the person of the designated recipient in a relatively secure area (under the hat, inside the underpants, etc.). Missives sent to those whose location is no longer correctly known end up in the cosmic dead-letter office and are subject to reading by outer beings.

Create Newt-Man

(Paolo Greco)

Spell Level: Magic-User, 2nd level

Range: Touch

Duration: Instantaneous

This spell accelerates spontaneous generation in any kind of moist filth, mire, morass, bogwater, or slough and creates 1d4 puny, indifferent newt-men magically bound to obey their creator.

Newt-men are kind of shitty servitors who can live indefinitely long, boring lives as lab workers, torchbearers, etc. They will comply with any order from their creator (save to resist at -2). When called upon for use in battle, they obey as reliably as ever, but the emotional shock of even one battle is too much for their frail constitutions. From this point forward the hapless newt-men actively seek oblivion in whatever fashion is most convenient. They might attack one another, fling themselves from the nearest cliff, or engage in any self-destructive, counterproductive behavior the DM can concoct.

Newt-Men are treated as "Special Hirelings", and if there are more than the maximum number allowed the PC, the extra Newt-Men must save each day (at sunset) or will pursue death-defying thrills like they're going out of style.

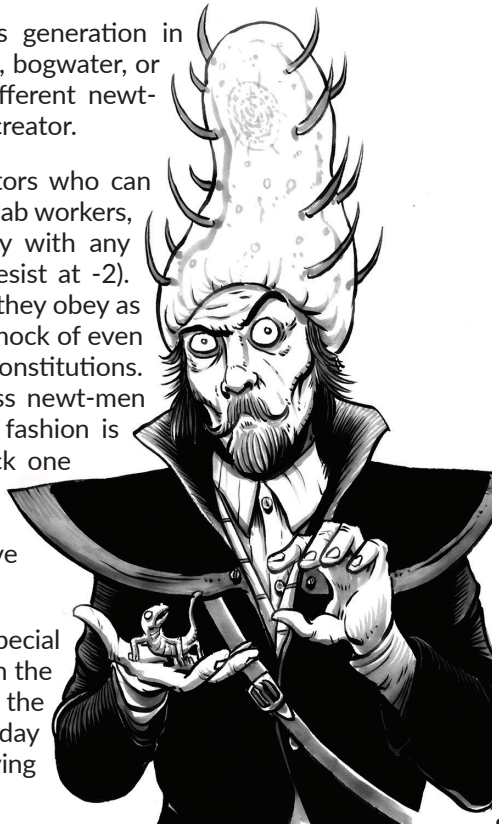

Enthrall Dim

Spell Level: Magic-User, 2nd level
 Range: Touch
 Duration: Lifetime of dim

Available only from magic-users in the employ of dim dealers in Slugtown on the Black Ooze River, this enchantment creates a bond of servitude between a dim and its master. Once enthralled, the dim will endeavor to obey its master's every command as best it can (given its limited intelligence).

Membranous Inconvenience

Spell Level: Magic-User, 2nd level
 Range: 30 feet
 Duration: 1 turn/level

The target (medium size or smaller) of this spell finds itself temporarily encysted in a slimy globule of dense protoplasm and in danger of suffocation (a successful saving throw allows the victim to sense the nascent reality breach and leap clear). The inconvenienced party can be freed by comrades or from within, provided the victim has a minimum STR of 14 or has a one-handed edged weapon. Either way, escape requires 2d6 rounds; saves vs. suffocation begin after a number of rounds equal to the victims CON.

Reveal Location

Spell Level: Magic-User, 2nd level
 Range: Unlimited
 Duration: Instantaneous

Magic-users (and others) use this enchantment primarily to transmit their current location to other magic-users in order to facilitate exchange of magic missives (q.v.). The spell may also be used to notify a single recipient of the caster's location in the form of an intrusive psychic vision that encompasses the caster and anything visible within 20 feet. If the location is unfamiliar to the recipient, they must infer what they can from the vision if they hope to ascertain the caster's whereabouts.

Decapitate

Spell Level: Magic-User, 3rd level
 Range: Touch
 Duration: Permanent

A surgical spell of the Nul cult, when cast upon a sleeping (or otherwise unconscious) subject decapitate painlessly removes the head, which dies while the body remains alive. Generally followed by an install antenna spell (q.v.).

Intervention in the form of a cure light wounds spell can reattach the head if applied within 10 minutes.

Diet of the Worm

Spell Level: Magic-User, 3rd level
 Range: 120 feet
 Duration: 1 turn/level

This spell continuously fills the belly of the target with rocks and soil, rendering the wretch a writhing, miserable heap capable only of vomiting up (or otherwise expelling) unbelievable volumes of earthy debris for the duration of the spell. Once the spell ends, the victim lies exhausted and likely weeping, able only to tremble and sweat for an additional 1d4 turns. A successful saving throw negates the major effects but leaves the target with a mouthful of mud and pebbles.

Hell's Mandibles

Spell Level: Magic-User, 3rd level
 Range: 60 feet
 Duration: 2 rounds/level

This spell conjures a set of fearsome spectral insect jaws and projects them toward an adversary of the caster's choice, whom they commence to bite like hell, attacking as a 4th-level fighter for 1d8+1 damage. Attacks continue automatically, allowing the magic-user liberty to pursue other interests. The caster can change the target of the mandibles by concentrating for one round, but can take no other action while doing so.

Install Antenna

Spell Level: Magic-User, 3rd level
 Range: Touch
 Duration: Permanent

Usually cast by a Nul surgeon-priest just after the application of a decapitate spell or ritual beheading, install antenna grafts a small processor box behind the breastbone of the subject, from which extends an aerial rod, thus creating a decapitante. The control box sends and receives telepathic messages and effects a complete metabolic restructuring, obviating the need for respiration and digestion (all nutrition and oxygenation of the blood provided by daily intravenous procedures).

Issha's Carapace of Corpulence

(Bobby Martin)

Spell Level: Magic-User, 4th level

Range: Self

Duration: 2d12 hours or until discharged

Issha's Carapace of Corpulence creates a magical, subdermal barrier beneath the skin of the caster which, to a casual observer, will appear as a thick layer of human fat.. For the duration of the spell (or if discharged; see below), any physical blow that deals a single point of damage is ignored, having failed to penetrate the sorcerous blubber.

Any blow that deals more than 1 point of damage causes the blubber to harden into an unbreakable shell, leaving the caster unable to move for 1 round while also rendering her invulnerable to any physical or magical harm for the remainder of the round. At the beginning of the following round, the layer turns into a disgusting yellowish slime and sloughs to the ground, the spell discharged.

Worm's Breath

Spell Level: Magic-User, 4th level

Range: 60' cone, 30' at end; forms 30' stationary cloud

Duration: 1 hour

This spell causes the caster to exhale a cone of fetid putrescent gas, like the unholy stench of 1,000 freshly opened graves on a hot summer day, except blasted straight up the nostrils with gale force. This cone lingers as a surging and heaving gray-green cloud. Characters and creatures caught in the area of effect must make a saving throw at -2 to avoid being immobilized by writhing and retching for the spell's duration or until physically removed from the area by unaffected associates. Nothing short of a strong wind will disperse the cloud before this time.

An unintended side effect of the spell is that it grants the caster immunity to gas effects, drowning, or anything that might compromise respiration as the spell renders the lungs metabolically inert for the duration (with none of the seemingly dire implications of this circumstance).

The spell has no effect on undead, shoggoths, otyughs, demons, or any creature already accustomed to living in shit, death, decay, and similarly horrible conditions.

Casters may wish to have a breath mint at hand once the spell concludes.

PLAYER BACKGROUND

If you love your DM, read this before play begins. If you lack basic human decency, your DM will summarize the basic information given here at the beginning of the session. But here it is. Save everyone some time.

Sorcerer-King Syantides, autocrat of the ancient city-state Mur, has made a terrible blunder. The fabulous Nul Rod (an anti-magical artifact of mythic proportions), long kept safely locked away in his Tower Impregnable, has been taken by one of Syantides' sons, the gallant Prince Eyraen.

Unable to master the mystic arts and doomed to obscurity in the shadows of his nine (confirmed) siblings, the Prince dedicated himself to mastering the arts of the war and became a mighty fighting-man and prominent explorer. While outfitting himself for an expedition, Eyraen discovered the Nul Rod among his father's substantial treasure hoard and appropriated the relic for use on a suicidal errand into the unfathomable Underworld.

At some point in their delve, the Prince's party met with a terrible fate from which only a single porter escaped. This young man, his hair prematurely white from terror, was able to offer very little in the way of coherent testimony before breaking free of his restraints and throwing himself into Stonespear River. The authorities found a rough map from the expedition in the youth's tattered sack, along with a small golden idol depicting a little-known godling, Shaggath-Ka the Worm Sultan. Former associates of the Prince confirmed that Eyraen had long a terrible vengeance upon the Worm Sultan, to whom one of the Prince's most ardent lovers was sacrificed in an unspeakable rite.

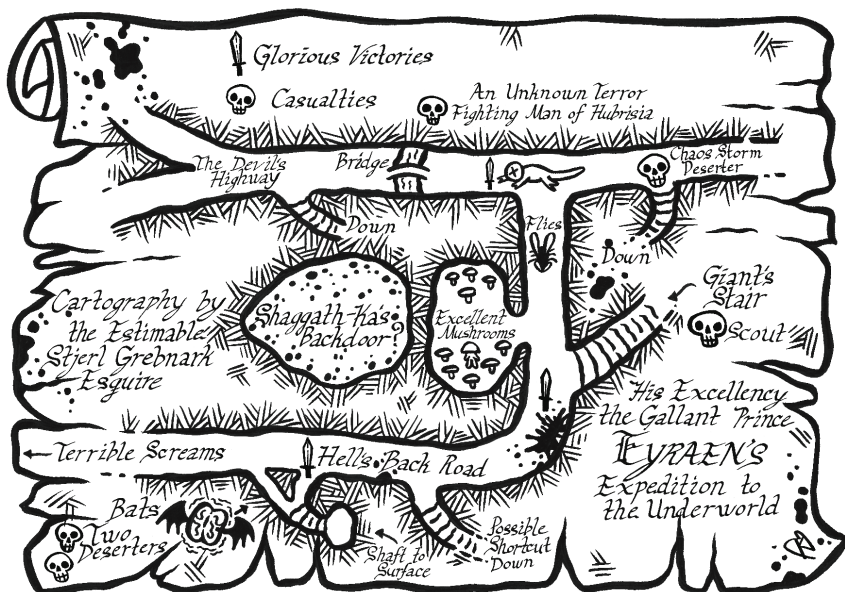

PLAYER BACKGROUND

According to the map, Shaggath-Ka's realm lies somewhere beneath the frontier territories to which your group has traveled in search of adventure. Just yesterday, the local captain attempted to plumb these depths with a sizable force of soldiers. A half-insane survivor, before renouncing his citizenship and disappearing into the night, reported that the war band attracted so much attention they were drawn into a series of nonstop battles. The captain and his remaining stalwarts fell in an encounter with a singular horror that the surviving man-at-arms was either unable or unwilling to describe. The agents of the Sorcerer-King hope that a smaller expedition, proceeding stealthily and choosing their battles wisely (this cannot be overemphasized), might have a better chance of success. The section of the Underworld visited by the Prince's party was at least partially pacified, and many horrors were destroyed. Certainly, whatever wiped out the party remains at large, but with care, planning, and stealth, the Nul Rod may still be recoverable. The further opportunity to reclaim any treasures procured by the Prince before fate overtook him should not be ignored.

The entrance to the Underworld used by the Prince lies but a few hours' travel into the nearby wilderness. But, with perpetual internecine wars raging on all fronts, most of the greatest heroes in the Sorcerer-King's service are dead, occupied, or very far away. And so in Fort Enterprise, the modest wilderness outpost you have chosen as your base of operations, the Sorcerer-King's regent has determined to press into service whomever he can find who might pass for bold adventurers. Your newly formed company, already planning a career in exploration, treasure hunting, and dungeon delving, will simply have to suffice.

As nominal subjects of the Sorcerer-King, you are officially compelled into service. However, the regent says, there shall no doubt be a princely reward for your efforts, to be determined in a face-to-face meeting with Syantides (a rare privilege indeed), should you succeed.

With only scant clues to follow, an incomplete map of Eyraen's expedition, and a few loaner magic items, your group must find the prince, dead or alive, and return with the relic. To further complicate matters, spies

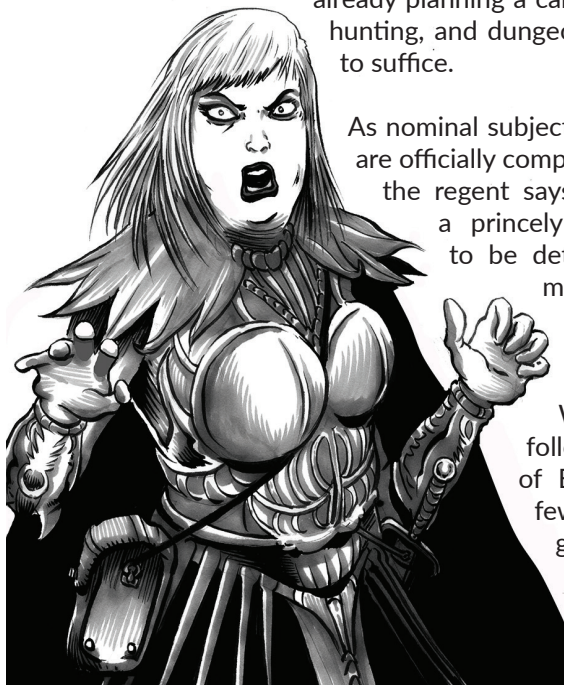

PLAYER BACKGROUND

within the Sorcerer-King's government have probably already reported to their nefarious masters the true nature of the relic and the prince's folly. Even now, other parties may be setting out on the same subterranean path. Time is of the essence!



UNDERWORLD FACTS AND TIPS

Collected bits of common wisdom available to new, native PCs. Visitors from adjacent dimensions will pick up most of this in due time if they hang out with unsavory adventuring types.

Fact: The Underworld is known to all as a vast mythic realm far beneath the world, a place of living legend and the source of nightmares, albeit ones that occasionally intrude into the waking world.

Fact: Most of the entrances to the Underworld in the civilized south are known and carefully watched over. Many were sealed long ago by great works of engineering and sorcery. But when the glaciers retreated during the most recent catastrophe, entrances inaccessible since the onset of the last ice age became usable. Several have been charted, but many more remain unknown.

Fact: Here in Stonespear Province, the primal source of Chaos seems closer at hand than in the south. Consequently, an inexhaustible variety of strange and terrible horrors stalk the local areas of the Underworld, blundering onto the surface from time to time.

Fact: Heroes of this world aspire to one day be masterful enough to pit their strength and fortitude against the horrors of the Underworld. An ancient tradition, still honored in many cultures, encourages aging warriors and adventurers to end their careers by setting off alone into the deeps, smashing Chaos in its nest before succumbing to their inevitable ends. Many religions contain clauses entitling those who perish in the Underworld to exalted status in the afterlife.

Fact: Dead heroes (from every epoch of the world, including those of extinct races) often leave behind fantastic relics and enchanted arms when they perish. Sometimes, in the Underworld, fabulous treasures are just left lying around waiting to be rediscovered by anyone brave or curious enough to look.

Fact: Secrets of the universe, the nature of creation, and other eldritch knowledge can only be had through studies of Primal Chaos and its source in the Underworld, a major draw for power-hungry sorcerers.



UNDERWORLD FACTS AND TIPS

Fact: In the Chaos-rich Underworld, the laws of nature that govern the surface world behave more like loose guidelines, prone to unannounced suspensions or inversions. You can trust gravity, for instance, most of the time.

Tip: Underworld groups and factions tend to hate each other much more passionately than you, whatever your crimes. Pit them against one another!

Tip: If you encounter surface folk, they are probably treasure hunters like yourselves, possibly vicious, likely treacherous, and might have already struck it rich. Consider robbing them.

Tip: Your intimate knowledge of *Monster Manuals* and *Fiend Folios* can avail you nothing here! Approach all creatures with due caution, sometimes the tiniest ones are the most lethal.

Tip: Find somewhere safe to stash treasure. If your DM is kind-hearted, this should count toward XP.

Tip: Sometimes even terrifying creatures just want a nice chat and might want to impart some of their Underworld wisdom. Try talking! From a distance!

Tip: You might find an occasional graven image of the prominent Underworld godlings on the main thoroughfares. A contribution of some small amount of coin might be a good idea.

Tip: When in doubt, seek concealment! Rumor has it there are relatively secure hidey-holes here and there.



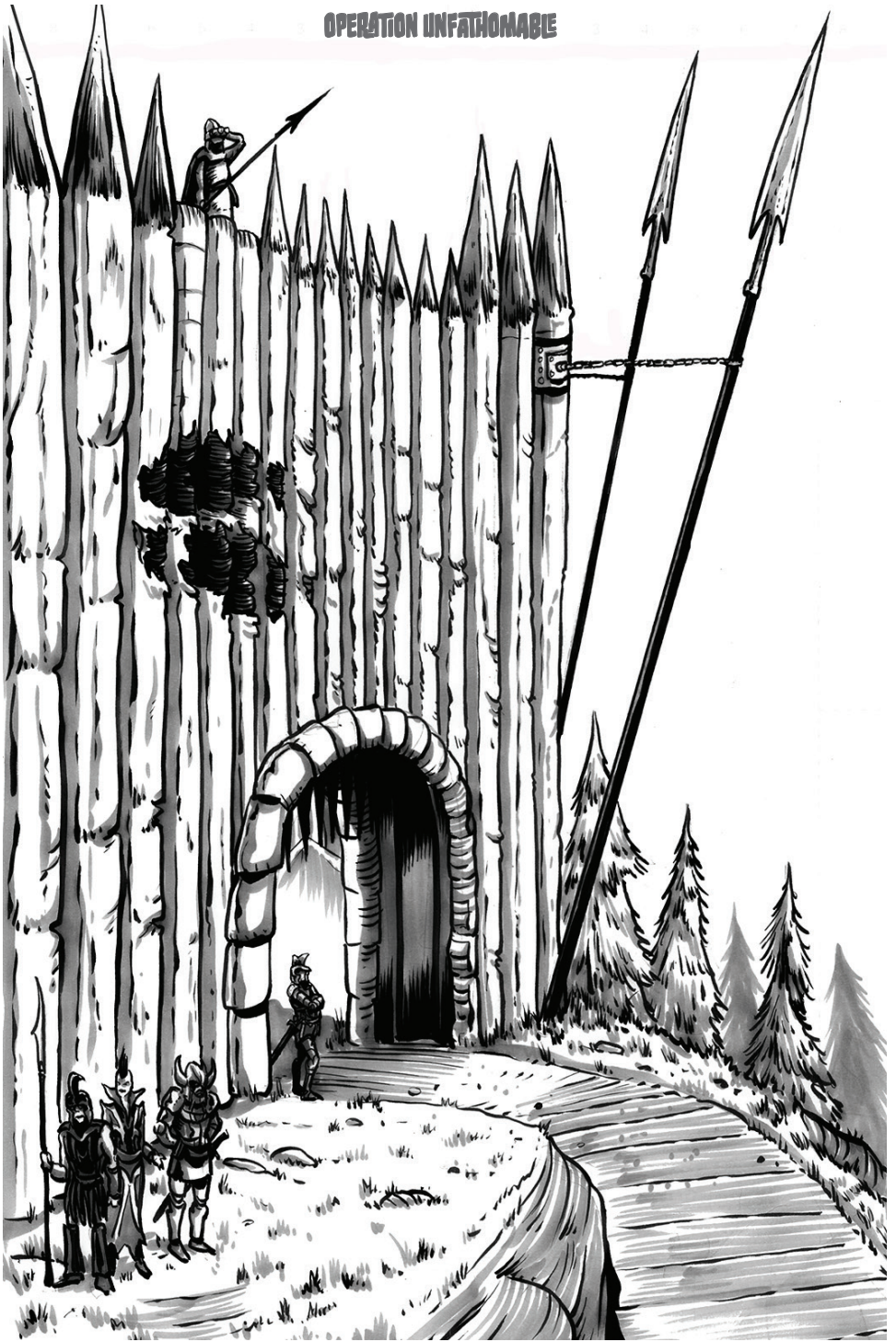

Fort Enterprise, Stonespear Province, Upper Mastodonia



The Fossil Forest, Second Wonder of the Uplands

OPERATION UNFATHOMABLE

[BEGIN OGL NOTIFICATION]

Open Game Content may only be Used under and in terms of the Open Game License Version 1.0a (OGL).

This entire work is designated as Open Game Content under the OGL, with the exception of the trademarks "Swords & Wizardry," "S&W," "Mythmere Games," "Operation Unfathomable" and any and all Operation Unfathomable logos, identifying marks, and trade dress; all proper nouns, monster names, NPC names, geographic terms, capitalized terms, italicized terms, boldfaced terms, artwork, maps, symbols, depictions, and illustrations, except such elements that are derived from the System Reference Document.

These trademarks, and the Trade Dress of this work (font, layout, style of artwork, etc.) are reserved as Product Identity.

OPEN GAME LICENSE Version 1.0a

The following text is the property of Wizards of the Coast, Inc. and is Copyright 2000 Wizards of the Coast, Inc ("Wizards"). All Rights Reserved.

1. Definitions: (a) "Contributors" means the copyright and/or trademark owners who have contributed Open Game Content; (b) "Derivative Material" means copyrighted material including derivative works and translations (including into other computer languages), potation, modification, correction, addition, extension, upgrade, improvement, compilation, abridgment or other form in which an existing work may be recast, transformed or adapted; (c) "Distribute" means to reproduce, license, rent, lease, sell, broadcast, publicly display, transmit or otherwise distribute; (d) "Open Game Content" means the game mechanic and includes the methods, procedures, processes and routines to the extent such content does not embody the Product Identity and is an enhancement over the prior art and any additional content clearly identified as Open Game Content by the Contributor, and means any work covered by this License, including translations and derivative works under copyright law, but specifically excludes Product Identity. (e) "Product Identity" means product and product line names, logos and identifying marks including trade dress; artifacts; creatures characters; stories, storylines, plots, thematic elements, dialogue, incidents, language, artwork, symbols, designs, depictions, likenesses, formats, poses, concepts, themes and graphic, photographic and other visual or audio representations; names and descriptions of characters, spells, enchantments, personalities, teams, personas, likenesses and special abilities; places, locations, environments, creatures, equipment, magical or supernatural abilities or effects, logos, symbols, or graphic designs; and any other trademark or registered trademark clearly identified as Product Identity by the owner of the Product Identity, and which specifically excludes the Open Game Content; (f) "Trademark" means the logos, names, mark, sign, motto, designs that are used by a Contributor to identify itself or its products or the associated products contributed to the Open Game License by the Contributor (g) "Use", "Used" or "Using" means to use, Distribute, copy, edit, format, modify, translate and otherwise create Derivative Material of Open Game Content. (h) "You" or "Your" means the licensee in terms of this agreement.

2. The License: This License applies to any Open Game Content that contains a notice indicating that the Open Game Content may only be used under and in terms of this License. You must affix such a notice to any Open Game Content that you Use. No terms may be added to or subtracted from this License except as described by the License itself. No other terms or conditions may be applied to any Open Game Content distributed using this License.

3. Offer and Acceptance: By Using the Open Game Content You indicate Your acceptance of the terms of this License.

4. Grant and Consideration: In consideration for agreeing to use this License, the Contributors grant You a perpetual, worldwide, royalty free, non-exclusive license with the exact terms of this License to Use, the Open Game Content.

5. Representation of Authority to Contribute: If You are contributing original material as Open Game Content, You represent that Your Contributions are Your original creation and/or You have sufficient rights to grant the rights conveyed by this License.

6. Notice of License Copyright: You must update the COPYRIGHT NOTICE portion of this License to include the exact text of the COPYRIGHT NOTICE of any Open Game Content You are copying, modifying or distributing, and You must add the title, the copyright date, and the copyright holder's name to the COPYRIGHT NOTICE of any original Open Game Content you Distribute.

7. Use of Product Identity: You agree not to Use any Product Identity, including as an indication as to compatibility, except as expressly licensed in another, independent Agreement with the owner of each element of that Product Identity. You agree not to indicate compatibility or co-adaptability with any Trademark or Registered Trademark in conjunction with a work containing Open Game Content except as expressly licensed in another, independent Agreement with the owner of such Trademark or Registered

Trademark. The use of any Product Identity in Open Game Content does not constitute a challenge to the ownership of that Product Identity. The owner of any Product Identity used in Open Game Content shall retain all rights, title and interest in and to that Product Identity.

8. Identification: If you distribute Open Game Content You must clearly indicate which portions of the work that you are distributing are Open Game Content.

9. Updating the License: Wizards or its designated Agents may publish updated versions of this License. You may use any authorized version of this License to copy, modify and distribute any Open Game Content originally distributed under any version of this License.

10. Copy of this License: You MUST include a copy of this License with every copy of the Open Game Content You Distribute.

11. Use of Contributor Credits: You may not market or advertise the Open Game Content using the name of any Contributor unless you have written permission from the Contributor to do so.

12. Inability to Comply: If it is impossible for you to comply with any of the terms of this License with respect to some or all of the Open Game Content due to statute, judicial order, or governmental regulation then you may not Use any Open Game Material so affected.

13. Termination: This License will terminate automatically if you fail to comply with all terms herein and fail to cure such breach within 30 days of becoming aware of the breach. All sublicenses shall survive the termination of this License.

14. Reformation: If any provision of this License is held to be unenforceable, such provision shall be reformed only to the extent necessary to make it enforceable.

15. COPYRIGHT NOTICE

Open Game License v 1.0a Copyright 2000, Wizards of the Coast, Inc. System Reference Document Copyright 2000-2003, Wizards of the Coast, Inc.; Authors Jonathan Tweet, Monte Cook, Skip Williams, Rich Baker, Andy Collins, David Noonan, Rich Redman, Bruce R. Cordell, John D. Rateliff, Thomas Reid, James Wyatt, based on original material by E. Gary Gygax and Dave Arneson.

Swords & Wizardry Core Rules, Copyright 2008, Matthew J. Finch

Bardolph's Commentary copyright 2017 Barry Blatt

Create Newt-man copyright 2017 Paolo Greco

Issha's Carapace of Corruptence copyright 2017 Bobby Martin

Operation Unfathomable, Copyright 2017, Jason Sholtis

END OF LICENSE

