

Fifth Edition Compatible

Deadly Dungeon Doors

The Dungeon Door Handbook

From *Dreadful Dungeons*



Version 1.03

Deadly Dungeon Doors



Written by: Glen Cooper

Credits

Proof Readers: Jeff Stevens, Ken Carcas

Artists: Glen Cooper & Neil Jary

Cover Illustration: Shutterstock.com

Feedback/Playtesting from: Adam Burchett, Joseph Antonie, Jeff Stevens, Trav Cramb, Jesse Dalton Robert-Edwards, James Baxter, Steve Barr, Jak McCoy, Peter Silver, David Richey, Thomas Engel, Seth Keown, Frito Garza Jr., Goraxe Meridian, Aaron Ash, Mertynas, Zelvys, Cory Ravn Green, James Glassbrook, Richard Penwarden, Anne Thornton, Rob Wunderlich, Joost Souffriau, Jak McCoy, Matt Quevillon, Matt Taylor, Curt Simcox.

Deadly Dungeon Door Competition Winners: Joseph Michael Stash III & Paul Brown.

Table of Contents

Foreword	3	Chapter 3 - 'Doors Happen' Tables.	22
Chapter 1 - The Past and Future.	4	Introduction	22
Introduction	4	Death Trap Dungeon	23
5e Rules - A Quick Glance	4	Mines Dungeon	25
Damage Severity	5	Tomb Dungeon	26
Skill Checks	5	Treasure Vault Dungeon	27
Toughness is New AC	5	The Volcano Dungeon	28
Toughness is Hit Points	5	Appendix A - Random Door Flowchart	29
How to Use this Resource.	6	Appendix B - Door Record Sheet I.	32
Chapter 2 - Random Dungeon Doors.	7	Appendix C - Door Record Sheet II	33
Complete Mayhem.	7	Appendix D - Glossary	34
Dungeon Door Materials	8	Appendix E - Legendary Deadly Dungeon Doors	39
Dungeon Door Types	9	Appendix F - Worked Example.	54
Secret Dungeon Doors	11	Appendix G - Trap Check List	55
Hidden Dungeon Doors	12	Appendix H - Monsters.	56
Locked Dungeon Doors	13	Appendix K - Addendums & Revisions	60
Trapped Dungeon Doors	14		
Dungeon Door Oddities	20		



DUNGEONS & DRAGONS, D&D, Wizards of the Coast, Forgotten Realms, the dragon ampersand, *Player's Handbook*, *Monster Manual*, *Dungeon Master's Guide*, D&D Adventurers League, all other Wizards of the Coast product names, and their respective logos are trademarks of Wizards of the Coast in the USA and other countries. All characters and their distinctive likenesses are property of Wizards of the Coast. This material is protected under the copyright laws of the United States of America. Any reproduction or unauthorized use of the material or artwork contained herein is prohibited without the express written permission of Wizards of the Coast.

©2016 Wizards of the Coast LLC, PO Box 707, Renton, WA 98057-0707, USA. Manufactured by Hasbro SA, Rue Emile-Boéchat 31, 2800 Delémont, CH. Represented by Hasbro Europe, 4 The Square, Stockley Park, Uxbridge, Middlesex, UB11 1ET, UK.

All other original material in this work is copyright [2017] by Glen Cooper and published under the Community Content Agreement for Dungeon Masters Guild

Dreadful Dungeons

FOREWORD

Hi! I'm excited to present to you my very first 5th Edition Dungeon Master's handbook and Player's guide. From the feedback already received, I know you are going to enjoy owning this supplement for many years to come.

Why did I write a guide on dungeon doors?

I guess I can track the idea back to a D&D session I was running, when our group of intelligent players fell foul of a rather nondescript and quite harmless door... this was right after defeating a troll and sneaking up on a fortified castle. The whole encounter seemed to be unbalanced and ridiculous - although very stressful at the time, we laughed about it afterwards. No one died, praise Sune!

Afterwards, I sketched out the offending door so that my players could see how ridiculous the encounter was and I suddenly found a hidden talent for drawing doors. I continued drawing more doors and eventually began creating backstories and rules for them. The rest, as we say, is history.

When I finally decided to write this supplement for us to enjoy I carried out A LOT of research on the current rules for opening doors, disarming door traps and of course random roll tables for their generation. I didn't want to change much of what was already out there - just tweak it and provide an explanation of some of the lesser known rulings. I found that it was a long and drawn out process skipping around the Dungeon Masters Guide. Also, I knew the information would be of great interest to certain players (thieves).

Finally, my intention was to get this whole process started with an offering which you could find a use for and inspire you to take use doors as encounters. I have heard many horror stories where DM's have pushed players beyond their limits and now consider doors to be a royal pain in the bottom.

Eventually, with your feedback, ideas, and additions, this PDF will grow and evolve into a much needed and valuable resource.

Please enjoy and be inspired by this resource.
See you in the dungeon soon!

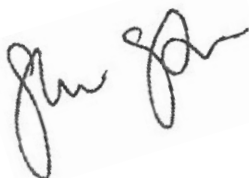

Glen Cooper (Dreadful Dungeons)

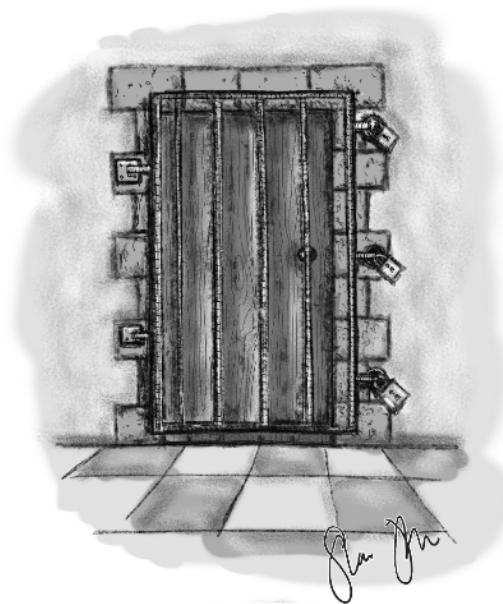

Chapter 1 - THE PAST AND FUTURE

If it doesn't open, it's not your door"
- Unknown

INTRODUCTION

This is our introduction to a slightly new way of thinking about dungeon doors in 5th Edition Dungeons & Dragons.

The DMG does have rules for breaking, opening, and disarming trapped doors, but the rules are found in several different chapters. We have nothing against the DMG. It's a GREAT book! However, if you have a dungeon door fetish like us... then it leaves too much to the imagination.

First, let us recap what we already know about dungeon doors from the DMG, with our notes attached. It won't take long, here goes.

5e RULES - A QUICK GLANCE

First of all, there is a random dungeon door table in the DMG on page 291. It's basic, but very quick and easy to roll a random door on the fly. No trapped doors though. So, stop looking for them.

Now if you want to determine the toughness or Armour Class of a door, you will need to turn to page 246 for a table of basic objects. These include wood, bone, stone, iron, etc. Now to find how many hit points, turn to next page and hey presto - you have a standard set of hit points for each door determined by its size (tiny/small/medium/large). A normal, resilient (medium) wooden door would have an AC of 15 and Hit Points of 18(4d8). Not rocket science, but just a bit awkward jumping around to find all this out.

We now have the basic door but what of secret doors, concealed doors, portcullises, locks, reinforced bars or traps?

For these we can find details in the dungeon features section of the DMG on pages 103-104.

This part covers skill checks for locked doors (lock picking), barging through stuck doors by use of Strength (Athletics) checks with a Difficulty Class (DC) as found in Chapter 8, "Running the Game".

Secret doors and concealed doors are very similar, but the latter involves rummaging about in a room and moving furniture to expose the hidden portal. The former involves detecting a door via a Wisdom (Perception) check with an appropriate DC set by the DM, OR perhaps the person who wrote the adventure modules you are running. Again turn to Chapter 8 for DCs.

Once a secret door is discovered then a new skill check is used, this time Intelligence (Investigation) to determine if they can figure out how to open it without having to break it through.

Thus, bringing us on to the final part - Traps. First of all, there is a rather useful Random Traps generator on page 297 of the DMG. It covers all the common parts of a dungeon; walls, floor, ceiling, chests and of course doors. But the situations are all merged into one. The tables allow for the random generation of the trigger for a trap, the severity of the damage and finally the 'Trap Effects'.. which is of course the real crowd pleaser. Inside all of these tables you can cobble together a trapped door by carefully choosing your options. Once you have the damage severity (Setback/Dangerous or Deadly), then you need to turn back to page 120 of the DMG for saving throw DCs and actual damage done in good old d10s.

Our supplement uses most of these rules but then builds upon them. You're welcome.

DAMAGE SEVERITY

Well, you can rest assured that we have used as much of the 5th Edition system as possible. HOWEVER, we did some things to the Armor Class and the Hit Point situation which we hope you'll love.

With regards to how dangerous each door is, this mechanic all hinges on the amount of damage which can be dealt to an adventuring party in a single turn.

All you do is select the level of the party as a whole, and then choose or roll randomly on how severe the damage will be - will it be a **Setback**? Or **Dangerous**? Or will it be **Deadly**? You simply cross reference the severity with the level of the adventuring party. 'Et voila', you have the damage dice needed. We kept that mechanic. We like that mechanic. Here's that mechanic again:

DAMAGE SEVERITY

1d20 1st - 4th LEVEL

1-9 Setback - 1d10

10-17 Dangerous - 2d10

18-20 Deadly - 4d10

SKILL CHECKS

A door's Difficulty Class (DC) is used to determine if a secret door can be spotted, or a lock can be picked, or perhaps even how easy is it to escape a trap once it's set off. There are many saving throws and skill checks which need determining so that you can negotiate your way past a challenging door situation.

Our dungeon door supplement doesn't mess with the original mechanic. It merely helps you by giving you a DC value for a given situation and door.

We have covered all the skill check explanations, and saves in the **Glossary Section in Appendix D**.

Think you're getting the hang of this now... so lets move on to our biggest offering which we have for dungeon doors. This is **Toughness**.

TOUGHNESS IS THE NEW AC

We love **Armor Class**, hence why we reference it so much, but **Toughness** is the new AC when we speak in door terminology. Or **Doorminology**. No?

This is how it works. Every door has been built in a certain way from particular materials (mostly from one simple material). Some doors are weaker than others, some have been damaged and other were poorly constructed. When you roll a door's **Toughness** this number represents its AC for hitting it. Toughness also represents its resistance to being barged open if it is heavy, big or just jammed closed. For the latter, simply use the door's Toughness as the DC to force it open. Found a gold door? Unlucky! A full list of materials can be found in the **Glossary Section in Appendix D**.

If you roll to hit a door and you miss, you only bounce off the surface or frame, doing cosmetic damage: scratches, scuffs, small dents.

TOUGHNESS IS HIT POINTS

Told you this was going to be easy. Yes, a door has a base Toughness which may be augmented up or down by its special construction. This is determined during the random generation of the door. The Toughness figure which you finally land upon is its Hit Points too.

This means a toughened door is heavy, robust and hard to 'kill'. Seriously... why did we even bother writing a supplement? We could have just Tweeted that.

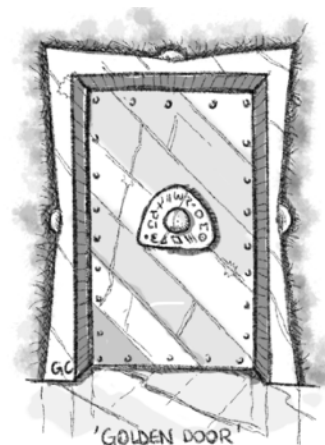

HOW TO USE THIS RESOURCE

Before you obtained your copy of Deadly Dungeon Doors (DDD) you may not have given doors a lot of thought. In truth, maybe all this talk about doors scared you and your players a little?

It is not our intention to inundate you with lots of new mechanics to worry about, or present a plethora of new ways to kill unprepared adventurers... even though that all sounds lovely. The intention of this resource book is to inspire you all. We want to awaken your mind to imaginative encounters involving doors.

Imagine, you're an adventurer slowly making your way up a set of dusty stone steps to a giant ivory door. It is engraved with runes around a central door handle, and menacing scratches are etched deep into its surface. You know that behind the door is what you came here looking for. The end game, the treasure room.

Here are a few scenario ideas on how to best make use of DDD.

THE FINAL ROOM

Even though there are many random door types which can be generated in tables later, by deciding that a door encounter will involve a trap and lock reduces down the options significantly for you.

Prior to game night, roll on the Door Materials table, or perhaps choose an exotic one ;). Then roll once on locks and once on traps. After randomly rolling the Difficulty Class of the doors attributes (unlock, spot, disarm etc), if you're feeling a bit frisky add a Door Oddity from Chapter 3 Table G.

There you have it, your end of dungeon door just got interesting.

RANDOM MAYHEM

Ah yeah, my favourite. This takes time and you should roll each door as part of your preparation for a dungeon adventure. If you have 20 doors to roll then you will need a good hour and a half to do this. You will get faster though, trust us.

Of course the result will be a dungeon madder than a box of Bullywugs. Doors of all sizes, types and materials bundled into one death trap dungeon.

THEMED DUNGEONS

What if you have a particular dungeon theme in mind and wish to control what materials make up the doors? If you have a Dwarven Mines idea for a dungeon, then simply make sure that 60-80% of all your dungeon doors are of a particular material and size. Or you could roll on the pre-generated dungeon doors in Chapter 2.

PRE-GENERATED DOORS

There are already a few tables to pre-generate your doors for a particular theme of dungeon. You may wish to create more of your own tables from the random tables provided. Perhaps you have a dungeon adventure which requires only silver doors? Then all you need do is create a table of random doors which are ready and waiting for you on game night.

If you do decide to create your themed dungeon tables please send them into us and we'll publish them if they are cool!

IMPROVISE

In the middle of a dungeon room encounter, the adventurers collapse a portion of the room, and now they are stuck!

You can easily pick up Chapter 3 and roll a secret/hidden door as they begin to search for a way out. The tables will talk you through its creation in no time at all.

Finally, you can have a lot of fun with rolling doors on the fly. One suggestion was to have an encounter with a Thieves Guild, who pit parties of adventures against one another in a time trial. They have a corridor each with 5 doors between them and freedom. All randomly rolled on the fly of course ;)

Please send to us your ideas and comments to [@DreadfulDungeon](#)

Chapter 2 - RANDOM DUNGEON DOORS

Anyone wanna play Dungeons & Dragons for the next quadrillion years?"
- Gary Gygax

COMPLETE MAYHEM

This section is for more advanced dungeon creators. Using the following tables in conjunction with the **Random Dungeon Door Flowchart** in **Appendix A** and the **Worked Example** in **Appendix F**, a dungeon designer can create over 6 million combinations of doors.

They will range from the mundane to the fantastical and beyond... but together they make no sense at all.

So please combine the following tables with your natural dungeon designers sensibility. If you wish to use them to create a new terror in the dark for an evenings roleplaying, then perhaps try using the themed and pre-generated doors in **Chapter 3** first.

We have received feedback that the random generator contained here is the source of much fun and inspiration. After rolling hundreds of doors ourselves we agree fully with the feedback. Rolling several doors definitely does inspire us to keep on rolling.

IT'S YOUR GAME

Finally, before you print off a few of the **Dungeon Door Record Sheets** in **Appendix B & C**, please remember that you can reject rolls or chose the results to suit your needs when designing a new dungeon adventure. Be flexible.

Also, don't forget to share some of your insidious creations with us on Twitter **@DreadfulDungeon**. We will look at them with our dungeon designer's goggles on and add the very best, funniest or most deadly to this supplement on regular supplement updates.

Remember to refer to the **Glossary Section** in **Appendix D** for more in depth explanations of terms and rulings.

You are going to enjoy what happens next... so get a nice cup of hot cocoa, your favourite pen and begin rolling your d20's.

Dungeon Doors just got nasty again...

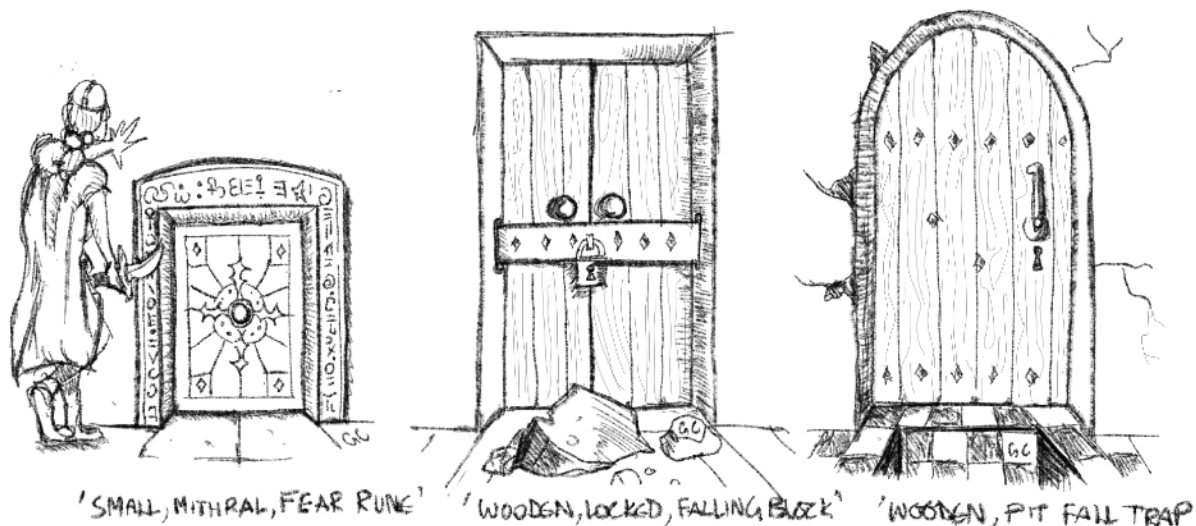

A - DUNGEON DOOR MATERIALS

The doors will be opened to those bold enough to knock.”
- Unknown

A1. DUNGEON DOOR MATERIAL TABLE

1d20	Door Material
1-2	Bone/Ivory (max Toughness = 15)
3-12	Wood (max Toughness = 20)
13-15	Stone (min Toughness = 10)
16-18	Iron (min Toughness = 10)
19	Exotic (roll on Exotic Door Material table A2)
20	Deadly Dungeon Door (roll on Deadly Dungeon Door table in Appendix E)

A2. EXOTIC DOOR MATERIAL TABLE

1d20	Door Material
1-6	Gold/Silver/Platinum (roll on door strength table, min Toughness 15, min jammed DC20, DC10 STRENGTH check to open)
7-12	Mithral (roll on door strength table and +5 to Toughness, min 20 Toughness)
13-17	Adamantine (roll on door strength table and +10 to Toughness, min 25 Toughness)
18-20	Crystal (roll on door strength table and -5 to Toughness, max 20 Toughness)

A3. DUNGEON DOOR TOUGHNESS TABLE

1d20	Door Toughness
1-3	Weak/Fragile (Toughness = 10)
4-12	Regular/Undamaged (Toughness = 15)
13-16	Strong/Robust (Toughness = 20)
17-20	Armoured/Toughened (Toughness = 25)

A4. DUNGEON DOOR SIZE TABLE

1d20	Door Size
1-4	Small
5-15	Regular
16-18	Large (+5 Toughness, DC10 STR check to open)
19-20	Huge/Giant (+10 Toughness, DC15 STR check to open)



B. DUNGEON DOOR TYPES

We keep moving forward, opening new doors, and doing new things, because we're curious and curiosity keeps leading us down new paths"
- Walt Disney

B1. BONE/IVORY DUNGEON DOORS

1d20 Door Properties/Type

1-10	Regular Door
11-13	Locked (roll on table E1)
14-16	Trapped (roll on table F1)
17-18	Trapped & Locked (roll on table E1 & F1)
19-20	**Special (roll on table B9)

B2. WOODEN DUNGEON DOORS

1d20 Door Properties/Type

1-10	Regular Door
11-13	Jammed (use Toughness as DC for STRENGTH check)
14	Barred (+3 Toughness unless removed)
15	Locked (roll on table E1)
16	Barred & Locked (+3 Toughness unless removed, roll on table E1)
17	Trapped (roll on table F1)
18	Barred & Trapped (+3 Toughness unless removed, roll on table F1)
19	Trapped & Locked (roll on table E1 & F1)
20	**Special (roll on table B9)

B3. STONE DUNGEON DOORS

1d20 Door Properties/Type

1-10	Regular Door
11-13	Jammed (use Toughness as DC for STRENGTH check)
14	Barred (+3 Toughness unless removed)
15	Locked (roll on table E1)
16	Barred & Locked (+3 Toughness unless removed, roll on table E1)
17	Trapped (roll on table F1)
18	Barred & Trapped (+3 Toughness unless removed, roll on table F1)
19	Trapped & Locked (roll on table E1 & F1)
20	**Special (roll on table B9)

B4. IRON DUNGEON DOORS

1d20 Door Properties/Type

1-10	Regular Door
11-13	Jammed (use Toughness as DC for STRENGTH check)
14	Barred (+3 Toughness unless removed)
15	Locked (roll on table E1)
16	Barred & Locked (+3 Toughness unless removed, roll on table E1)
17	Trapped (roll on table F1)
18	Barred & Trapped (+3 Toughness unless removed, roll on table F1)
19	Trapped & Locked (roll on table E1 & F1)
20	**Special (roll on table B9)

B5. GOLD/SILVER/PLATINUM DUNGEON DOORS

1d20 Door Properties/Type

1-10	Regular Door
11	Barred (+3 Toughness unless removed)
12	Locked (roll on table E1)
13	Barred & Locked (+3 Toughness unless removed, roll on table E1)
14	Trapped (roll on table F1)
15	Barred & Trapped (+3 Toughness unless removed, roll on table F1)
16	Trapped & Locked (roll on table E1 & F1)
17-20	**Special (roll on table B9)

B6. MITHRAL DOORS

1d20 Door Properties/Type

1-10	Regular Door
11	Barred (+3 Toughness unless removed)
12	Locked (roll on table E1)
13	Barred & Locked (+3 Toughness unless removed, roll on table E1)
14	Trapped (roll on table F1)
15	Barred & Trapped (+3 Toughness unless removed, roll on table F1)
16	Trapped & Locked (roll on table E1 & F1)
17-20	**Special (roll on table B9)

B7. ADAMANTINE DOORS

1d20 Door Properties/Type

1-10	Regular Door
11	Barred (+3 Toughness unless removed)
12	Locked (roll on table E1)
13	Barred & Locked (+3 Toughness unless removed, roll on table E1)
14	Trapped (roll on table F1)
15	Barred & Trapped (+3 Toughness unless removed, roll on table F1)
16	Trapped & Locked (roll on table E1 & F1)
17-20	**Special (roll on table B9)

B8. CRYSTAL DUNGEON DOORS

1d20 Door Properties/Type

1-10	Regular Door
11-12	Locked (roll on table E1)
13-14	Trapped (roll on table F1)
15-16	Trapped & Locked (roll on table E1 & F1)
17-20	**Special (roll on table B9)

B9. **SPECIAL DOORS

1d20 Door Properties/Type

1-2	Sliding door or Portcullis (made from iron or stone, Toughness is Strength DC for sliding/lifting)
3-4	Locked Sliding or Portcullis (made from iron or stone, roll on random Strength Table for DC of sliding/lifting, roll on table E1)
5-6	False Door (regular size, cannot break through, Spot DC10)
7	Trapped False Door (regular size, cannot break through, roll on table F1)
8-9	Hidden Door (roll on Hidden Door table D1)
10	Locked Hidden Door (roll on Hidden Door table D1, roll on locks table E1)
11	Trapped Hidden Door (roll on Hidden Door table D1, roll on traps table F1)
12-14	Secret Door (roll on table C1)
15-16	Locked Secret Door (roll on table C1, roll on locks table E1)
17-18	Trapped Secret Door (roll on table C1, roll on traps table F1)
19-20	Mimic (see Appendix H: Monsters)

C. SECRET DUNGEON DOORS

Still round the corner there may wait, A new road or a secret gate.”
- J. R. R. Tolkien

SECRET DOORS ‘THE DEFINITION’

Secret doors are disguised to look like the wall/floor/ceiling of the room in which they are found. These doors need to be spotted in order to find them.

C1. SPOT DC

1d20 Spotting DC

1-2 The door is obvious (DC13)

3-5 Easy (DC14)

6-10 Moderate (DC15)

11-14 Well Hidden (DC18)

15-18 Hard (DC20)

19 Very Hard (DC25)

20 Nearly Impossible (DC30)

C2. OPEN DC

1d20 Opening DC

1-2 Very Easy (DC5)

3-6 Easy (DC10)

7-10 Moderate (DC15)

11-16 Hard (DC20)

17-18 Very Hard (DC25)

19-20 Nearly Impossible (DC30)



D. HIDDEN DUNGEON DOORS

Everything we see hides another thing, we always want to see what is hidden by what we see.”
- Rene Magritte

HIDDEN DOORS ‘THE DEFINITION’

Hidden doors are doors obscured by another object in a room/corridor. Once the object is moved then the position of the door becomes obvious.

D1. SPOT DC

1d20 Spotting DC

1-3 Moderate (DC15)

4-15 Hard (DC20)

16-17 Very Hard (DC25)

18-20 Nearly Impossible (DC30)

D2. FURNITURE HIDDEN BEHIND

1d20 Furniture

1-2 Behind or under a rug/tapestry/curtain on the wall.

3-4 Behind or under a large wardrobe/cupboard.

5-6 Behind a mirror/painting.

7-8 Behind or under a bookcase/throne/table

9-10 Buried behind or under a slight cave in/ceiling collapse.

11-12 Disguised by an illusionary segment of the wall.

13-14 Behind a statue or suit of armour.

15-16 Behind a weapon rack.

17-18 Under or behind some garbage/litter.

19-20 Behind or under a stack of barrels.

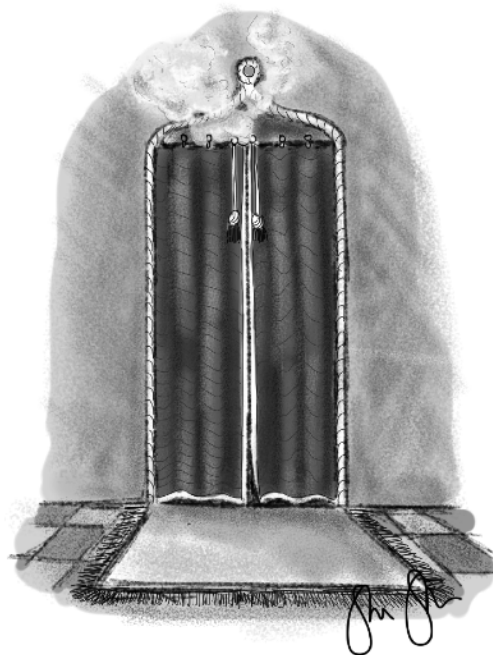

E. LOCKED DUNGEON DOORS

An unlocked door means that, occasionally, you might get a devil come in, but a locked door means you have thousands of angels just walk by.”
- Ian MacKaye

E1. LOCK TYPE

1d20 Lock Properties/Type

1-10	Sliding bolt with iron padlock (Toughness 15)
11-12	Rim lock (Toughness 20)
13-14	Mortice lock (Toughness 25)
15-16	Sliding bolt on opposite side (same toughness as door, +10 to Spot DC)
17	Rim lock on opposite side (same toughness as door, +5 to Spot DC)
18-19	Arcane Lock (+10 to the Toughness of Door, can be dispelled with DC15, If Arcane Lock is rolled again then re-roll unless the door has multiple locks. In which case, apply Arcane Lock to the door again.)
20	Multiple locks (extra locks are always sliding bolts with iron padlocks, re-roll on the table to determine the first lock once again. If multiple locks are rolled again, then add another sliding bolt with iron padlock and roll again).

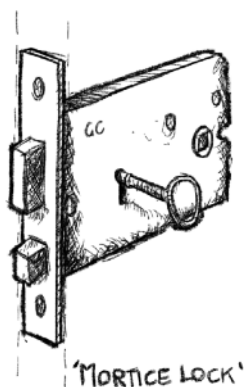

E2. SPOT DC

1d20	Spotting DC
1-10	Lock is obvious (N/A)
11-14	Very Easy (DC5)
15-16	Easy (DC10)
17	Moderate (DC15)
18	Hard (DC20)
19	Very Hard (DC25)
20	Nearly Impossible (DC30)

E3. UNLOCK DC

1d20	Lock Picking DC
1	Very Easy (DC5)
2-3	Easy (DC10)
4-10	Moderate (DC15)
11-16	Hard (DC20)
17-18	Very Hard (DC25)
19-20	Nearly Impossible (DC30)

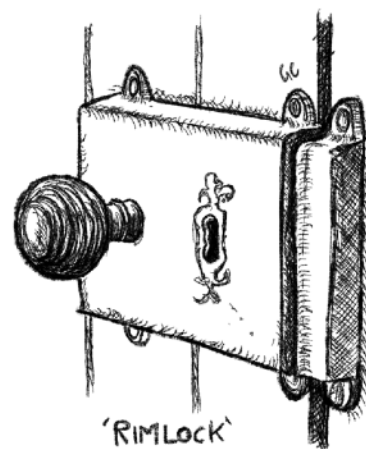

F. TRAPPED DUNGEON DOORS

Short cuts make long delays.”
- J. R. R. Tolkien

F2. SPOT DC

1d20 Trap Spotting DC

1-2 Trap is obvious (N/A)

3-6 Very Easy (DC5)

7-10 Easy (DC10)

11-14 Moderate (DC15)

15-18 Hard (DC20)

19 Very Hard (DC25)

20 Nearly Impossible (DC30)

F3. DISARM DC

1d20 Trap Disarming DC

1-2 Very Easy (DC5)

3-6 Easy (DC10)

7-10 Moderate (DC15)

11-16 Hard (DC20)

17-18 Very Hard (DC25)

19-20 Nearly Impossible (DC30)

F4.1 DAMAGE SEVERITY

1d20 1st - 4th LEVEL

1-9 Setback - 1d10

10-17 Dangerous - 2d10

18-20 Deadly - 4d10

F4.2 DAMAGE SEVERITY

1d20 5th - 10th LEVEL

1-9 Setback - 2d10

10-17 Dangerous - 4d10

18-20 Deadly - 10d10

F4.3 DAMAGE SEVERITY

1d20 11th - 16th LEVEL

1-9 Setback - 4d10

10-17 Dangerous - 10d10

18-20 Deadly - 18d10

F4.4 DAMAGE SEVERITY

1d20 17th - 20th LEVEL

1-9 Setback - 10d10

10-17 Dangerous - 18d10

18-20 Deadly - 24d10

F5.1 SAVE DC & ATTACK BONUS

1d20 Damage Severity - Setback

1-6 DC10, Attack Bonus +3

7-12 DC10, Attack Bonus +4

13-17 DC11, Attack Bonus +4

18-20 DC11, Attack Bonus +5

F5.2 SAVE DC & ATTACK BONUS

1d20 Damage Severity - Dangerous

1-6 DC12, Attack Bonus +6

7-12 DC13, Attack Bonus +7

13-17 DC14, Attack Bonus +7

18-20 DC15, Attack Bonus +8

F5.3 SAVE DC & ATTACK BONUS

1d20 Damage Severity - Deadly

1-6 DC16, Attack Bonus +9

7-11 DC17, Attack Bonus +10

12-15 DC18, Attack Bonus +11

16-18 DC19, Attack Bonus +11

19-20 DC20, Attack Bonus +12

F1. TRAP TYPE

1d20 Trap Properties/Type

- 1 **Poison Darts** - (mechanical trap) use **Spot DC WISDOM** (Perception) to detect holes which fire a swarm of darts from the walls or alcove. Anyone within a 15ft radius of the door will be attacked by 1d4 darts. Each dart must roll to hit on a d20 using their attack bonus. Each dart causes 1d4 piercing damage adding the **Damage Class** damage dice also (as a poison attack). A passed CONSTITUTION save using the **Save DC** will halve the damage. If the trap is spotted and then INTELLIGENCE (Investigation) check is made using **Disarm DC**, then a PC will find that the trap is triggered by a pressure plate (20lbs of weight sets it off). The trap can be disarmed by blocking all the holes using wax or some other substitute (no check needed), OR by spiking the pressure plate (DEXTERITY check using **Disarm DC**). A failed check activates the trap.
- 2 **Explosive Fireball** - (magic trap) use **Spot DC WISDOM** (Perception) to detect strange runes inscribed around the stem of the door handle and/or scorch marks around the door frame and on the threshold. Anyone within a 20ft radius of the door will be hit by a fireball exploding from the centre of the door, should it be triggered. It causes the damage as stated in **Damage Class** PLUS any creature within 5ft of the door will be blown back 10ft if they fail a STRENGTH (Athletics) save. Being blown back 10ft results in 1d6 bludgeoning damage as they hit the floor/wall. A DEXTERITY (Acrobatics) save will prevent them from being knocked prone. A DEXTERITY (Acrobatics) save with **Save DC** will halve the overall damage of the trap. If a trap is spotted and then INTELLIGENCE (Arcana) check is passed using **Disarm DC**, then a PC will find that the trap is triggered by moving the handle/latch one particular way. The trap can only be temporarily disarmed by using a dispel magic spell, OR by moving the door handle/latch the opposite way. Disarming the trap lasts for 1d10 minutes.
- 3 **Lightning Bolt** - (magic trap) use Spot DC WISDOM (Perception) to detect 3 white ceramic tiles hidden in the door frame design, plus soot marks on the grout of each tile. Should the trap be triggered by simply touching the door handle a trio of lightening bolts converge on the creature standing closest to the door but no further than 10ft away. It causes the damage as stated in the Damage Class. Damage is doubled for anyone wearing metal chain, splint or plate armour. A passed DEXTERITY (Acrobatics) save with Save DC will halve the damage. If the trap is spotted then INTELLIGENCE (Arcana) check is made using Disarm DC, then a PC will find that the trap is probably triggered by touching the handle. The trap can only be temporarily disarmed by using a dispel magic spell, OR by opening the door from a distance with say 'mage hand' or something similar. Disarming the trap lasts for 1d10 minutes.
- 4 **Pit Fall** - (mechanical trap) use Spot DC WISDOM (Perception) to a slightly out of level threshold for the door. Stamping on the threshold (trap door) will reveal a hollow sound and a cavity beneath. The depth of the pitfall will directly coincide with the Damage Class. 1d10 = 18ft, 2d10 = 36ft, 4d10 = 72ft, 10d10 = 72ft + spikes. A passed DEXTERITY save using the Save DC will halt their fall by bracing themselves against opposite walls (advantage for huge creatures and disadvantage for small creatures) after sliding 1d10ft past the floor level. Then a STRENGTH (Athletics) check is required each 10ft to climb out of the pit. Failing a STRENGTH check will make the creature to slip a further 1d10ft downwards and force another DEXTERITY save or they will drop the rest of the distance to the bottom of the pit. If the trap is spotted and then INTELLIGENCE (Investigation) check is made using Disarm DC, then a PC will find that the trap is triggered by a pressure plate (20lbs of weight sets it off). The trap can be disarmed by spiking the pressure plate in 2 separate locations (DEXTERITY check using Disarm DC). A failed check sets it off and anyone standing on the plate will fall in as before.
- 5 **Poison Needle** - (mechanical trap) use Spot DC INTELLIGENCE (Investigation) to reveal that the locking/opening mechanism has been adjusted to make space for a needle trap. Anyone attempting to open the door via the handle/latch/lock will be stabbed by a 3 inch long poisoned needle. The needle causes 1 piercing damage added to the Damage Class (as a poison). A passed CONSTITUTION save using the Save DC will halve the poison damage. If the trap is spotted then a DEXTERITY check using Disarm DC is required to open the door/lock without setting off the needle trap. Failing to remove the needle in time will set off the trap.

F1. TRAP TYPE

1d20 Trap Properties/Type

- 6 **Flame Thrower** - (magic trap) use Spot DC WISDOM (Perception) to detect scorch marks around the mouth of 2 of the many small painted faces on the door. Anyone within a 30ft cone of the door will be hit by a flamethrower jetting from the 2 faces, should it be triggered. It causes the damage as stated in Damage Class. A passed DEXTERITY (Acrobatics) save with Save DC will halve the damage. If the trap is spotted and then INTELLIGENCE (Arcana) check is made using Disarm DC, then a PC will find that the trap is triggered by a pressure plate in the floor (20lbs of weight sets it off). The trap can be disarmed by spiking the pressure plate in 1 location (DEXTERITY check using Disarm DC) OR casting dispel magic (Disarm DC). A failed check sets it off and anyone standing on the plate and within the 30ft cone will automatically be hit by the flames. If the trap is disarmed by dispel magic, this lasts for 10 minutes.
- 7 **Acid Spray** - (mechanical trap) use Spot DC WISDOM (Perception) to detect an elongated hole, halfway up the door pointed towards anyone who approaches it. The hole is encircled with a metal rim. The door is also slightly discoloured below the hole and in various places - like splash marks. The floor is worn away on the threshold. Anyone within a 10ft cone of the door will be hit by a spluttering jet of strong acid, should the trap be triggered. It causes the damage as stated in Damage Class. A passed DEXTERITY (Acrobatics) save with Save DC will halve the damage. The damage will continue into the next turn if their clothes/armor are not partially removed in time. On the second turn, a successful DEXTERITY save will allow the PC to remove the affected items enough to only take half damage (this may be quarter damage if they already succeeded on the first DEX save). This trap permanently reduces the AC of any non-magical armor by -2 until the armor is repaired. If a trap is spotted and then INTELLIGENCE (Investigation) check is made using Disarm DC, then a PC will find that the trap is triggered by a pressure plate in the floor (20lbs of weight sets it off). The trap can be disarmed by spiking the pressure plate (DEXTERITY check using Disarm DC). A failed check sets it off and anyone standing on the plate and within the 10ft cone will automatically be hit by the acid spewing forth. The trap can be disarmed for 3 turns by plugging the hole with something which does not corrode too quickly (like metal or stone).
- 8 **Cone of Cold** - (magic trap) use Spot DC WISDOM (Perception) to detect tiny little cold fractures around a series of small white gems set into the door. If activated, anyone within a 30ft. cone of the door will be hit by a subzero blast of cold air emanating from the white gems. It causes the damage as stated in Damage Class PLUS the creatures speed is reduced to half for 3 turns as their clothes, armor and skin are partly frozen. Any undrawn non-magical weapons will require thawing out for at least 3 turns before they can be drawn from their scabbards or sleeves. A passed CONSTITUTION save with Save DC will halve the cold damage. If a trap is spotted and then INTELLIGENCE (Arcana) check is made using Disarm DC, then a PC will find that the trap is triggered by a pressure plate in the floor (20lbs of weight sets it off). The trap can be disarmed by spiking the pressure plate in a single location (DEXTERITY check using Disarm DC) OR casting dispel magic (using Disarm DC). A failed check sets it off and anyone standing on the plate and within the 30ft cone will automatically be hit by the icy blast. If the trap is disarmed by dispel magic, this lasts for 10 minutes. Special note: If a creature is hit twice with a cone of cold and fails the CONSTITUTION save twice in a row, then a 3rd CONSTITUTION save is required to avoid being turned into a solid block of ice. They are immediately unconscious, and they will begin suffocating until thawed out by some manner of heat or magic.
- 9 **Sleep Gas Cloud** - (mechanical trap) use Spot DC WISDOM (Perception) to detect the smell of ammonia. On the floor are raised brass bulges the size of large fists, which if you fell on them they probably would make a big dent in your head. Anyone within a 20ft radius of the door will be hit by a gaseous cloud of ammonia, if the trap is triggered. Roll the Damage Class damage dice as usual. Any creature within the 20ft radius which has less hit points than the dice rolled will automatically fall asleep for 1 minute and take 1d6 bludgeoning damage as they helplessly collapse onto the brass bulges on the floor. If a trap is spotted and then INTELLIGENCE (Investigation) check is made using Disarm DC, then a PC will find that the trap is triggered by a pressure plate in the floor (20lbs of weight sets it off). The trap can be disarmed by spiking the pressure plate (DEXTERITY check using Disarm DC). A failed check sets it off and anyone standing on the plate and within the 20ft radius will automatically be hit by the cloud of gas. A creature who covers their mouth or holds their breath can survive the cloud of sleep gas with a successful CONSTITUTION save.

F1. TRAP TYPE

1d20 Trap Properties/Type

- 10 **Poison Gas Cloud** - (mechanical trap) use Spot DC WISDOM (Perception) to detect a pair of hidden vents, one either side of the door. Anyone within a 20ft radius of the door will be hit by a cloud of poisonous gas, if the trap is triggered. Roll the Damage Class dice as usual but halve this damage on a successful CONSTITUTION save. If trap is spotted and then INTELLIGENCE (Investigation) check is made using Disarm DC, then a PC will find that the trap is triggered by a trip wire across the door. The trap can be disarmed by cutting the wire (DEXTERITY check using Disarm DC). A failed check sets it off and anyone standing within the 20ft radius will automatically be hit by the cloud of gas. A creature who covers their mouth or holds their breath can survive the cloud of sleep gas with a successful CONSTITUTION save.
- 11 **Collapsing Roof / Falling Block** - (mechanical trap) use Spot DC WISDOM (Perception) to detect a slight depression in the floor, plenty of cracks and a slight discolouration to the ceiling. Anyone standing in front of the door will be hit and possibly crushed by a block falling or part of the ceiling collapsing, if the trap is triggered. Roll the Damage Class dice as usual but halve this damage on a successful DEXTERITY save. If trap is spotted and then INTELLIGENCE (Investigation) check is made using Disarm DC, then a PC will find that the trap is triggered by a pressure plate in the floor (20lbs of weight sets it off). The trap can be disarmed by spiking the pressure plate (DEXTERITY check using Disarm DC). A failed check sets it off and anyone standing directly on the plate will suffer the damage as described above. Special Note: IF a creature fails their DEXTERITY save by more than 10 or roll a natural 1, then they need to save versus STRENGTH to avoid being pinned by the blocks and will suffer half damage each and every turn until they escape by successfully passing a STRENGTH (Athletics) check. This check can be assisted (advantage) if friends choose to help move the biggest block(s).
- 12 **Psychic Blast** - (magic trap) use Spot DC WISDOM (Perception) to detect strange runes inscribed around the stem of the door handle/latch and a very low humming sound. Should the trap be triggered by simply touching the door handle/latch a painful blast of psychic energy enters their mind. A passed INTELLIGENCE save with Save DC will halve the damage. If the trap is spotted then INTELLIGENCE (Arcana) check is made using Disarm DC, then a PC will find that the trap is probably triggered by touching the handle/latch. The trap can only be temporarily disarmed by using a dispel magic spell, OR by opening the door from a distance. IF however, a PC uses magic, with say 'mage hand' or something similar the psychic blast will still travel into the mind of the PC opening the door. Disarming the trap lasts for 1d10 minutes.
- 13 **Guillotine / Scythe Blade** - (mechanical trap) use Spot DC WISDOM (Perception) to detect a razor thin slot above the door and a chopped and worn groove on the bottom door frame. If the trap is set off, a super fast blade of steel springs down from the frame to slash into anything below it for the Damage Class damage. First check to see if it hits using the to hit bonus. A passed DEXTERITY save using the Save DC will halve the damage. If trap is spotted and then INTELLIGENCE (Investigation) check is made using Disarm DC, then a PC will find that the trap is triggered by a trip wire across the door. The trap can be disarmed by cutting the wire (DEXTERITY check using Disarm DC). A failed check sets it off and anyone passing through the door will get hit.
- 14 **Steel Maw** - (mechanical trap) use Spot DC WISDOM (Perception) to detect a slightly lower floor threshold, a joint along the centre of the door. Anyone standing in front of the door when it is opened will automatically be attacked as it folds down the centre long ways and attempts to grapple and crush the creature. Roll first to see if it hits using the attack bonus. If it hits, then roll the Damage Class dice as usual but halve this damage on a successful STRENGTH save (disadvantage for small creatures and advantage for large creatures) . A second successful STRENGTH save will enable the creature to free itself with no more damage. This save can be assisted by 2 other creatures pulling the jaws away in opposite directions. If the 2nd STRENGTH save is unsuccessful then the creature suffers half damage again and has another opportunity to escape next turn. If trap is was spotted and then INTELLIGENCE (Investigation) check is made using Disarm DC, then a PC will find that the trap is triggered by swinging open the door. The trap can be disarmed by jamming the mechanism on both the door hinges using a pair of iron spikes (DEXTERITY check using Disarm DC). A failed check sets it off and anyone standing directly in front of the door suffers the damage as described above. If the door grapples 2 creatures at once, they count as one large creature.

F1. TRAP TYPE

1d20 Trap Properties/Type

- 15 **Rune of Confusion** - (magic trap) use Spot DC WISDOM (Perception) to detect strange runes inscribed around the frame of the door which are part hidden into the ornate stonework. Should the trap be triggered by simply walking through the door with eye open then the trap's rune begins to effect the creature(s) in 1d4 rounds. A passed CHARISMA save with Save DC will resist the runes effects and they will immediately feel that something had just invaded their mind for a moment before dispersing. If the trap is spotted then INTELLIGENCE (Arcana) check is made using Disarm DC, then a PC will find that the trap is triggered by walking through the door, but they will not know that by closing their eyes the effects will be dispelled for that creature. The trap can also be temporarily disarmed by using a dispel magic spell, OR closing the door and casting Arcane Lock. Disarming or Arcane Locking the door lasts for 1d10 minutes before it resets. If a creature fails it's CHARISMA saving throw, then roll 1d8: 1-4 the creature does nothing and stands still, dribbling or looking vacantly into the distance, 5-6 the creature takes no action but uses all it's movement to move in a random direction, 7-8 the creature makes one melee attack against a random (closest) creature or does nothing if no creature is within reach.
- 16 **Rune of Fear** - (magic trap) use Spot DC WISDOM (Perception) to detect strange runes inscribed around the frame of the door which are part hidden into the ornate stonework. The trap can be triggered by simply standing 10ft in front of the door. A passed WISDOM save with Save DC will resist the runes effects. If the trap is spotted then INTELLIGENCE (Arcana) check is made using Disarm DC, then a PC will find that the trap is triggered by being in close proximity to the door. The trap can only be temporarily disarmed by using a dispel magic spell, OR closing the door and casting Arcane Lock. Disarming or Arcane Locking the door lasts for 1d10 minutes before it resets. If a creature fails it's WISDOM save, it will immediately be fearful of the door. They will not move towards the door until they successfully make the saving throw, EVEN if the alternative is harm from another creature or encounter in the same room. The only other way to undo the effects of the fear rune is that if another source of fear forces the creature to run away from it through the door.
- 17 **Teleporter Crystal** - (magic trap) No perception check is needed here. A huge golden coloured crystal (parent crystal) adorns the centre of the door that match many other crystals of the same colour which are embedded into the door threshold (floor). The trap can be triggered by simply walking onto the threshold in front of the door, any creatures who do this, will automatically disappear - no save. A passed INTELLIGENCE save with Save DC will guide the body of the teleported creature back to the same point of teleportation in 1d10 minutes. A failed save will send them immediately to one of a random set of locations (set by DM) or perhaps a predetermined location. Returning to the same door again is impossible without the parent door crystal. If the trap is spotted then INTELLIGENCE (Arcana) check is made using Disarm DC, then a PC will find that the trap is triggered by being in close proximity to the door - 5ft. The trap can only be temporarily disarmed by using a dispel magic spell. Disarming the trap lasts for 1d10 minutes before it resets.
- 18 **Magic Missile Trap** - (magic trap) No perception check is needed here. The door is decorated with as many arrow heads as d10's in the Damage Class of the trap. The arrow heads point out of the door and into the room. The trap can be triggered by touching the door handle/latch. When activated each arrow head fires a magic missile at the occupants of the room. It will spread the missiles evenly amongst all the rooms occupants, but any odd missiles left over will all hit ONE creature at random. A passed DEXTERITY save will reduce the damage by a half by offering up a less critical part of the body to take the missile. If the trap is spotted then an INTELLIGENCE (Arcana) check is made using Disarm DC, then a PC will find that the trap is triggered by touching the door. The trap can only be temporarily disarmed by using a dispel magic spell. Disarming the trap lasts for 1d10 minutes before it resets. Also a creature with the shield spell will automatically catch any missiles fired at it as a reaction.

F1. TRAP TYPE

1d20 Trap Properties/Type

- 19 **Electrified Floor-tile / door-handle** - (magic trap) use Spot DC WISDOM (Perception) to detect the metal nature of the threshold and scorch marks around the door handle/latch. The trap is triggered by standing on the metal threshold and touching the handle/latch at the same time. Should the trap be triggered then a powerful shock passes through the creature. Use the Damage Class damage and the creature is immediately stuck to the handle/latch. Each turn that the creature is 'stuck' to the handle/latch another Damage Class damage is passed through the creature. A passed CONSTITUTION save with Save DC will halve the damage (disadvantaged if wearing metal armour). A passed DEXTERITY save will enable the creature to avoid being stuck by pulling back from the latch/handle before it fully takes hold BUT they will automatically drop one item they may have in their free hand... perhaps lock picks? A potion? Or a weapon? If the trap is spotted then INTELLIGENCE (Arcana) check is made using Disarm DC, then a PC will find that the trap is probably triggered by touching the handle/latch whilst standing on the floor plate. The trap can only be temporarily disarmed by using a dispel magic spell, OR by opening the door from a distance. Disarming the trap by magic lasts for 1d10 minutes. Opening the door severs the traps trigger too. If a creature is electrified, then by removing them from the door will halt the damage, but anyone grabbing the electrified creature risks being stuck themselves. Use the same saves as before. 2 creatures will share the damage equally each turn. The sticking effects of the electrocution can be broken using a STRENGTH check using the Disarm DC.
- 20 **Sonic Attack** - (magic trap) use Spot DC WISDOM (Perception) to detect small fragments of glass laying on the floor in the vicinity of the door plus the odd damp patch. The trap will be triggered by opening the door. Once triggered a high pitched squeal will become audible to all those within 60ft of the door. A passed DEXTERITY save with Save DC will allow creatures to quickly cover their ears with their hands (dropping a single loosely held item of their choosing to do so), this will halve the Damage Class damage. In addition, a passed CONSTITUTION save will also halve the damage (creatures which have advantage to perception checks by using their ears, are deafened for 1d4 minutes). The sonic blast will continue to sound so long as the door is left open. If the trap is spotted then INTELLIGENCE (Arcana) check is made using Disarm DC, then a PC will find that the trap is triggered by opening it. The trap can only be temporarily disarmed by using a dispel magic spell, OR closing the door. Disarming or closing the door lasts for 1d10 minutes before it resets. If the sonic blast is allowed to continue for a 3 turns, then any non-magical glass or crystal items must save versus shattering using an unmodified roll against the trap save roll.

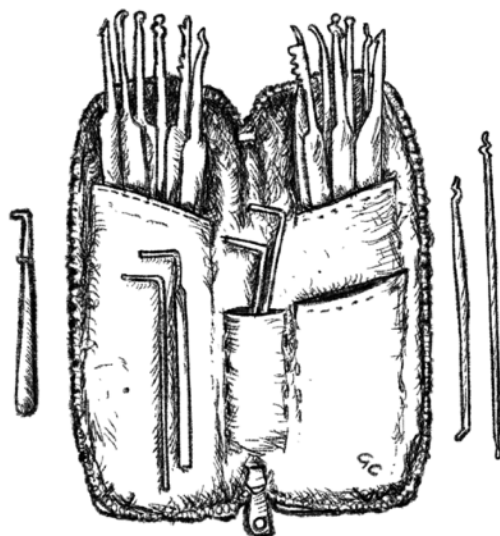

'LOCK PICKS'

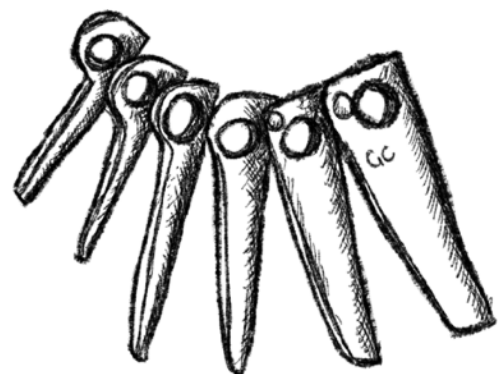

'PITONS'

G. DUNGEON DOOR ODDITIES

nature hath framed
strange fellows in her
time.”
- William Shakespeare

G1. STRANGE PROPERTIES

1d20 Number of Properties

1-14 None

15-17 Roll once on oddity table

18-19 Roll twice on oddity table

20 Roll 3 times on oddity table

G2. STRANGE PROPERTIES

1d100 Oddity Type

1-2 Slightly damp / condensation / wet

3-4 Rusty / tarnished / mouldy / minor fractures / pock marks

5-6 Recently repaired

7-8 Odd colour / painted / stained / mottled / cloudy

9-10 Grooves / Claw marks / Scratches

11-12 Charred marks / soot / melted patches

13-14 A faint glow / minor magic signature

15-16 Door handle/latch and frame made of a particular material (roll on materials table)

17-18 Door is split in 2 in the middle horizontally. Each with it's own properties! **Stop** here immediately and roll a brand new door to be the top half of the door.

19-20 Door is slightly ajar. Then closes shut as they approach to within 10ft.

21-22 Has a slightly higher than usual threshold. (DEX save with DC10 to run into and out of room via this door)

23-24 Missing it's latch/handle. Needs breaking down or picking with DC10.

25-26 Cracked right through it. -5 Toughness.

27-28 Door slightly too short for frame, and provides a half inch gap at the bottom.

29-30 Broken throwing axe embedded into the now split wooden door frame.

31-32 Has a lock (roll for one) but it is unlocked. Scrape marks on the lock.

33-34 A hastily painted face is on the front of the door (Roll 1d6: 1-2. A dragon, 3. A goblin, 4. A beholder, 5. An orc, 6. A demon)

35-36 Knock-Knock is engraved in (1d6: 1-Elvish, 2-Dwarvish, 3-Arcane, 4-Thieves Cant, 5-Druidic, 6-Abyssal) onto the door.

37-38 A chain with a broken manacle hangs down from the wall to the right of the door.

39-40 Cob webs cover the door...

41-42 Door is spiked closed from this side (remove or DC25 to barge open).

43-44 Peephole (able to roll a 'sight' perception check to next room with a disadvantage).

45-56 **Knocker** (see Knockers Table G3)

57-58 Doorknob falls off as it is touched (see 15-16 on this Table).

59-60 Thing(s) nailed/attached to the door/door frame (1d6: 1-small animal pelts, 2- trinket (roll on Trinkets p.160 PHB), 3- iron bucket, 4-dead flowers, 5-broken flute, 6-mirror)



G2. STRANGE PROPERTIES (CONT.)

1d100 Oddity Type

61-62 A brass bell (ringing it alerts inhabitants of next room that PC's are coming).

63-64 Iron chain which hangs down beside the door (use it to open door upwards like a portcullis).

65-66 1d4 Unlocked sliding door bolts/latches.

67-68 Door is decorated with an open curtain either side (1d4: 1-blue, 2-red, 3-yellow, 4-green).

69-70 Sticky. The door is covered with a sticky residue (light items will stick to it - like lock picks and daggers. Dexterity/Strength DC5 to remove).

71-72 Door is hinged at the bottom (to avoid falling through it when opening, pass a Dexterity Save DC15, or land prone 5ft on the other side of the door as the PC trips up).

73-74 Door has silence cast on it (it makes no sound, not even if they break it through. It can be dispelled with DC10).

75-76 Door has many (1d10) magnetic studs in it (any light metal items are immediately attracted to it. Spot DC25, Dexterity/Strength DC10 hold onto or to remove anything loose which is attracted to it).

78-80 Green ooze dripping down from the top (this is acid and easily avoidable. If touched then take 1d4 Acid Damage).

81-82 The door has 1d4 lighted torches on the wall next to it. Easily removable.

83-84 The door frame is wooden and 1d4 rotten arrows are sticking out of it.

85-86 The door has tiny vents/holes in it (Spot DC 10).

87-88 Door is spiked closed from the other side (remove or DC25 to barge open, Spot DC15).

89-90 Door or wooden frame is smouldering and blackened. Warm to the touch.

91-92 **Knocker** (see Knockers Table G3)

93-94 Door handle is a carved dragon.

95-96 Door handle is a carved ogre hand.

97-98 1d4 bones of a human are nailed to it.

99-00 1d4 bones of a dwarf are nailed to it.

G3. DOOR KNOCKERS

1d20 Knocker Type

1-11 Iron ring with a heavy ball to strike another metal plate. Knocking will alert anything in the next room.

12-13 A black dragon's head door knocker. It is sticky with acid (1d4 acid damage if touched). The acid will eat away at anything which touches it unless it is doused in water to dilute it in 1d4 rounds.

14-15 A knocker in the shape of a fist, rapping the door. Made from a hollow crystal. It will shatter if used and cause 1d4 piercing damage to bare skin. Lightly tapping will do nothing.

16 A bronze genie's lamp hangs by it's spout. If anyone knocks the lamp against the door have all PC's roll a Wisdom Save. To the lowest scoring PC whisper to them "*Your wish, has been granted...*". That's it. The effect can be dispelled with DC15.

17 A gold leaf (worth 60gps) hinges from the door. Knocking it will immediately begin the growth of vines and roots from the cracks in the walls, floor and ceiling. The surfaces are now rough terrain. After 1d4 turns the vines will grow around the door and jam it shut with a Strength check DC20 required to open it.

18 Invisible door knocker. Dispel will reveal it for 1d10 turns. If the PC's knock it, then it will heal that PC for 1d10 hit points. Once healing has been cast, it disappears for a day. Spot DC20 whilst opening the door will reveal a slight unbalancing. A heavy swing will generate an audible slam sound. The knocker will remain until a creature uses it.

19 A marble angel's face. This is an animated door knocker. If a PC opens the door and is **evil** or **chaotic** in alignment, then it will begin rapping itself many times every few seconds for 1d10 minutes. Alerting the next room of their presence. If a good or lawful PC uses the knocker then it will cast bless on them for the next hour (once per day).

20 Magical. This silver knocker looks like an old bearded half-elf. Knocking on it 2 times in quick succession will unlock all of the doors locks. Knocking 3 times (1 extra time), will disarm any magical traps. Taking it from the door will remove all it's powers, but it is worth 40gp.

Chapter 3 - 'DOORS HAPPEN' TABLES

If anyone locked me in a dungeon, there'd be screams."
- Terry Pratchett

INTRODUCTION

Designing dungeons can be a long and tortuous process. We have found some cool tables in the DMG which begin on page 73, 'Dungeon Goals'. There is some great content there which could easily inspire you to begin building your very own dungeon.

Next up, if you turn to page 99-101, you will find some fantastic little random dungeon design tables. They deal with questions like; Who created the dungeon? What alignment were they? What was their class? And the purpose for the dungeon's creation and its history.

If you are just starting out as a DM in Dungeons & Dragons then we whole heartedly recommend you roll a few dungeon's goals for inspiration. Also this process helps for the next part of this dungeon door supplement.

Example: *Your adventuring party discover the nature of and origin of a strange dungeon nearby - a tomb built to preserve the remains of all the heroes slain by a lawful evil Lich who was once a local forest Druid. He still presides over his tomb, slowly filling the dark space deep underground with more dead bodies of treasure hunting adventurers.*

We created the above dungeon backstory based completely on rolls made from tables found in the DMG. We can now select the Tomb 'theme' on table 2.3 and use the pre-generated doors there.

In **Chapter 2** we presented a scratch built dungeon door system. But quite often the doors generated do not make much thematic sense. Plus designing each and every door can take a while. So we have put together 5 dungeon themed tables with pre-generated doors for speedy use.

Our dungeon themes include:

1. Death Trap Dungeon (tables 2.1 & 2.2)
2. The Mines (tables 2.3 & 2.4)
3. The Tomb (tables 2.5 & 2.6)
4. Treasure Vault (tables 2.7 & 2.8)
5. The Volcano (tables 2.9 & 3.0)



'WOODEN, MIMIC'

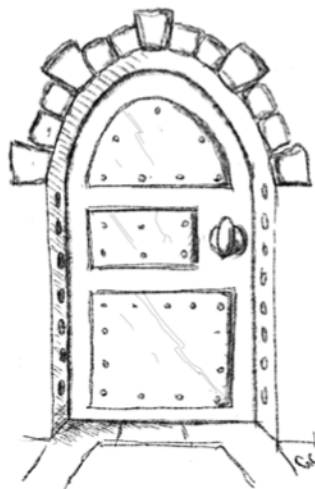

'IRON, POISON DARTS'

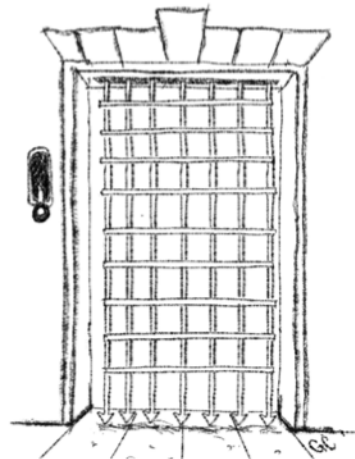

'SILVER, PORTCULLIS'

THE DEATH TRAP DUNGEON

News of the now famous deadly dungeon filters through the adventurer's rumour mill in the big city. It becomes a matter of pride amongst the 'green horns' to find the entrance and defeat the dungeon. Veterans know better though.

"No one ever returns. No maps exist. Death awaits the ill-prepared."

2.1 DUNGEON DOOR TYPE AND PROPERTIES

1d20 DOOR TYPE

1-8 **Standard Dungeon Door** - Wooden, undamaged (Toughness 15), regular size, no traps, not locked.

9 **Falling Block Trap!** Wooden, undamaged (Toughness 15), regular size, Falling Block trap (see table F1), Spot DC15, Disarm DC25, Damage Severity - Deadly, Save DC 17)

10 **Locked!** Wooden, strong (Toughness 20), regular size, Rim lock on opposite side of door (Toughness 20), Spot DC15, Unlock DC20, Cobwebs over the door...

11 **False Door and Electrified.** Cannot be broken through, Iron, strong (Toughness 25), large size (Strength check with DC10 to realise it is false), Electrified trap (see table F1), Spot DC20, Disarm DC30, Damage Severity - Deadly, Save DC 18)

12 **Barred & Locked.** Stone, undamaged (Toughness 18), regular size, Sliding bolt with iron padlock (Toughness 15), Spot DC10, Unlock DC5, Claw marks over the door...

13 **Small, jammed, wooden door.** Wooden, undamaged (Toughness 15), small size, Jammed shut (Strength check DC15), Missing handle (break down door or pick with DC15), sliding bolt on other side of door (unlocked).

14 **Trapped & Locked.** Iron, weak (Toughness 15), large size (Strength check with DC10 to realise it is false), Sliding bolt (Toughness 15), Spot (obvious), Unlock DC20, Rune of Confusion (see table F1), Spot DC20, Disarm DC15, Damage Severity - Deadly, Save DC16), Scratch marks, Knock-Knock in Thieves Cant is engraved into the iron door.

15 **Trapped, Barred Door.** Wooden, undamaged (Toughness 18), regular size, Barred, Poison Gas Cloud (see table F1), Spot DC10, Disarm DC5, Damage Severity - Deadly, Save DC 16,

2.1 DUNGEON DOOR TYPE AND PROPERTIES (CONT)

1d20 DOOR TYPE

16 **Trapped and Locked Adamantine Door** - Adamantine, undamaged (Toughness 35), regular size, Sliding bolt (Toughness 15), Spot (obvious), Unlock DC20, Arcane lock, Sliding bolt (Toughness 25), Spot DC5, Unlock DC15, Cone of Cold trap (see table F1), Spot DC5, Disarm DC15, Damage Severity - Deadly, Save DC20, charred marks all over it (see table G2).

17 **Trapped and Locked Mithral Door** - Mithral, undamaged (Toughness 20), regular size, Rim lock (Toughness 20), Spot (obvious), Unlock DC10, Steel Maw trap (see table F1), Spot DC20, Disarm DC20, Damage Severity - Deadly, Save DC16 (Atk +9).

18 **Small Wooden Door** - Wooden, undamaged (Toughness 18), small size, Barred, recently repaired, slightly ajar (see table G2).

19 **Pit Fall, Iron Door Trap** - Iron, undamaged (Toughness 15), regular size, Pit Fall trap (see table F1), Spot DC10, Disarm DC30, Damage Severity - Deadly, Save DC17, door slightly too short providing half inch gap at bottom.

20 **Locked Bone Door** - Bone, undamaged (Toughness 15), regular size, sliding bolt on opposite side of door (Toughness 15), Spot (obvious), Unlock DC25, slightly wet, red, fractured.

Design Notes:

- All traps are automatically 'deadly'.

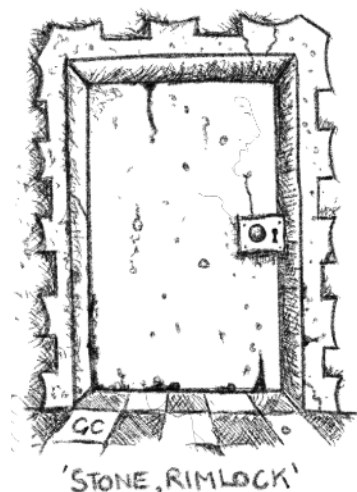

2.2 SPECIAL DUNGEON DOOR TYPE AND PROPERTIES

1d20 SPECIAL DOOR TYPE

1-4 **Door Behind a Throne** - Wooden, undamaged (toughness 15), regular size, hidden behind throne, Spot DC20, rim lock (toughness 20), Spot (obvious), Unlock DC15, mouldy.

5-8 **Stone Portcullis** - Stone, undamaged (toughness 15), regular size, portcullis (Strength check DC25), unlocked sliding bolt, has a faint green glow and faint aura of magic.

9-12 **Small Wooden Door** - Wooden, undamaged (Toughness 18), small size, Barred, recently repaired, slightly ajar (see table G2).

13-16 **Secret Bone door with Trap** - Bone, undamaged (toughness 15), large (strength check DC10 to open), secret door, Spot DC20, Open DC10, Lightning Bolt trap (see table F1), Spot DC20, Disarm DC10, Damage Severity - Deadly, Save DC16, Attack Bonus +9, cracked right through it.

17-20 **Split Door - Door 1** (top) Iron, undamaged (toughness 15), regular size, Mimic (see Appendix H: Monsters). **Door 2** (bottom), Iron, weak (toughness 13), barred, rim lock on opposite side of door (toughness 13), Spot DC5, Unlock DC20, cob webs cover door.

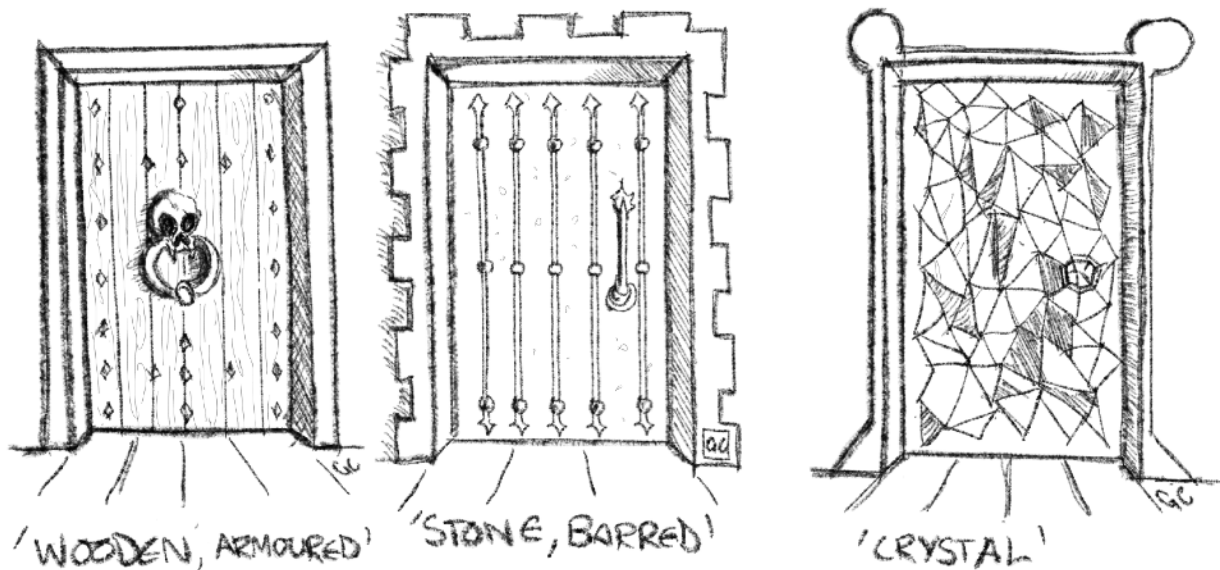

THE MINES DUNGEON

In the Underdark, a Dwarvern mine twists back and forth, driving its way deep into the mountainside. The rooms are damp and fashioned from the same stone taken from the many hard-worked rock faces.

2.3 DUNGEON DOOR TYPE AND PROPERTIES

1d20 DOOR TYPE

1-8 **Standard Dungeon Door** - Stone, undamaged (Toughness 15), regular size, no traps, not locked.

9 **Jammed Large Stone Door** - Stone, strong (toughness 25), large, jammed, (Strength check DC25 to open), soot marks.

10 **Trapped Golden Door** - Gold (Strength check DC10 to open), undamaged (toughness 15), regular size, Psychic Blast trap (see table F1), Spot DC25, Disarm DC10, Damage Severity - Dangerous, Save DC12, +6 Attack.

11 **Small Bone Locked Door** - Bone, strong (toughness 20), small size, sliding bolt (toughness 15), Spot DC5, Unlock DC25, magical aura, broken throwing axe in wooden frame, missing its door handle (Unlock DC10)

12 **Wooden Trapped Door** - Wood, undamaged (toughness 18), regular size, barred, sleep gas cloud trap (see table F.1), Spot DC10, Disarm DC30, Damage Severity - Dangerous, Save DC15, Attack +8, has hastily painted goblin face on it.

13 **Trapped Iron Door** - Iron, strong (toughness 23), regular size, barred, Acid Spray trap (see table F1), Spot DC10, Disarm DC10, Damage Severity - Setback, Save DC10, +3 Attack, cob webs across door, rusty.

14 **Small Locked Iron Door** - Iron, strong (toughness 33), small size, barred, Arcane (Dispel DC15).

15 **Trapped Stone Door** - Stone, Armoured (toughness 25), regular size, Guillotine trap (see table F1), Spot DC15, Disarm DC20, Damage Severity - Dangerous, Save DC12, +6 Attack, handle and frame made from iron.

16 **Large Locked Wooden Door** - Wood, undamaged (toughness 23), large size, barred, rim lock on opposite side of door (toughness 23), Spot DC10, Unlock DC15, half inch gap at bottom of frame.

2.3 DUNGEON DOOR TYPE AND PROPERTIES (CONT)

1d20 DOOR TYPE

17 **Trapped Giant Wooden Door** - Wood, strong (toughness 30), giant (DC15 Strength check to open), sliding bolt (toughness 15), Spot (obvious), Unlock DC15, Magic Missile trap (see table F1), Spot DC10, Disarm DC15, Damage Severity - Setback, Save DC10, +3 Attack.

18 **Yellow Wooden Door** - Wood, undamaged (toughness 15), regular size, Jammed (DC10 strength check to open), stained yellow, unlocked sliding bolt on opposite side of door.

19 **Large Trapped Iron Door** - Iron, strong (toughness 25), large size (Strength DC10 check to open), sonic attack trap (see table F1), Spot DC25, Disarm DC15, Damage Severity - Setback, Save DC10, Attack +4.

20 **Crystal Wooden Door** - Crystal, undamaged (toughness 13), regular size, barred, Explosive Fireball trap (see table F1), Spot DC20, Disarm DC10, Damage Severity - Setback, Save DC11, +5 Attack.

2.4 SPECIAL DUNGEON DOOR TYPE AND PROPERTIES

1d20 SPECIAL DOOR TYPE

1-4 **Locked Iron Door** - Iron, undamaged (toughness 15), regular size, Secret Door, Spot DC15, Open DC15, sliding bolt (toughness 15), Spot (obvious), Unlock DC15.

5-8 **Wood Mimic** - Wood, armoured (toughness 25), small size, Mimic (see Appendix H: Monsters).

9-12 **Iron Portcullis** - Iron, undamaged (toughness 15), regular size, Portcullis (Strength check DC15 to lift), a chain with a broken manacle hangs down from the wall to the right of the door.

13-16 **False Stone Door** - Stone, undamaged (toughness 20), large size, False Door (cannot be broken through), handle and frame made from crystal.

17-20 **Secret Trapped Wood Door** - Wood, armoured (toughness 25), regular size, Secret Door, Spot DC30, Open DC20, Teleporter Crystal (see table F1), Spot DC10, Disarm DC30, Damage Severity - Setback, Save DC10, Attack +3.

THE TOMB DUNGEON

A short journey away from a busy metropolis, a cold and dusty tomb has attracted tomb robbers for years. Its maze like complex of rooms is guarded by strange beasts. Doors of bone and iron keep them trapped inside for all of eternity.

2.5 DUNGEON DOOR TYPE AND PROPERTIES

1d20 DOOR TYPE

- 1-5 **Standard Dungeon Door** - Bone, undamaged (Toughness 15), regular size, no traps, not locked.
- 6-10 **Standard Dungeon Door II** - Iron, undamaged (Toughness 15), regular size, no traps, not locked.
- 11 **Trapped Bone Door** - Bone, undamaged (Toughness 15), regular size, Poison Darts trap (see table F1), Spot DC5, Disarm DC20, Damage Severity - Deadly, Save DC20, +12 Attack.
- 12 **Large Bone Locked Door** - Bone, undamaged (Toughness 20), large size (Strength DC10 check to open), rim lock (Toughness 20), Spot (obvious), Unlock DC20, higher than usual threshold (see table G2)
- 13 **Iron Locked Door** - Iron, strong (Toughness 18), regular size, barred, sliding bolt (Toughness 15), Spot (obvious), Unlock DC15, cracked right through it.
- 14 **Stone Door** - Stone, armoured (Toughness 28), regular size, barred, charred marks, condensation.
- 15 **Trapped Wood Door** - Wood, strong (Toughness 25), large size (Strength DC10 check to open), sliding bolt on reverse side of door (Toughness 25), Spot DC20, Unlock DC20. Falling Block trap (see table F1), Spot DC10, Disarm DC20, Damage Severity - Setback, Save DC10, Attack +4.
- 16 **Trapped Adamantine Door** - Adamantine, undamaged (Toughness 25), regular size, Flame Thrower trap, Spot DC10, Disarm DC25, Damage Severity - Setback, Save DC11, Attack +4.
- 17 **Small Iron Door** - Iron, undamaged (Toughness 15), small size, jammed (Strength DC15 to open), unlocked sliding bolt with padlock.

2.5 DUNGEON DOOR TYPE AND PROPERTIES (CONT)

1d20 DOOR TYPE

- 18 **Locked Bone Door** - Bone, undamaged (toughness 15), regular size, Lock 1 - Sliding lock (toughness 15), Spot (obvious), Unlock DC15, Lock 2 - Sliding lock (Toughness 15), Spot DC5, Unlock DC20, hastily painted on face of a demon in blood.
- 19 **Large Trapped Locked Bone Door** - Bone, undamaged (Toughness 20), large size (Strength DC10 to open), Sliding bolt on opposite side of door (Toughness 20), Spot DC15, Unlock DC15, Acid Spray trap, Spot DC20, Disarm DC10, Damage Severity - Dangerous, Save DC12, Attack +6.
- 20 **Large Stone Door** - Stone, undamaged (Toughness 15), Large size, Jammed (Strength DC15 to open), soot marks, missing its door knob (requires Unlocking DC10).

2.6 SPECIAL DUNGEON DOOR TYPE AND PROPERTIES

1d20 SPECIAL DOOR TYPE

- 1-4 **Skin of Sin** - See Legendary Deadly Dungeon Doors in Appendix E!
- 5-8 **Split Door** (table G2). **Door 1 (upper)** - Stone, undamaged (Toughness 15), regular size, false door (cannot break through), Spot DC10. **Door 2 (lower)** - Stone, weak (Toughness 10), regular size, sliding lock and padlock (Toughness 15), Spot DC5, Unlock DC20.
- 9-12 **Hidden Bone Door** - Bone, undamaged (Toughness 15), regular size, hidden door, Spot DC20, behind bookcase/throne/table.
- 13-16 **Secret Mithral Door** - Mithral, undamaged (Toughness 15), regular size, Secret door, Spot DC15, Open DC20, Psychic Blast trap, Spot DC5, Disarm DC5, Damage Severity - Deadly, Save DC18, Attack +11.
- 17-20 **Hidden Trapped Iron Door** - Iron, undamaged (Toughness 15), regular size, hidden door, Spot DC25, behind rug/tapestry/curtain, Poison Darts trap, Spot DC15, Disarm DC20, Damage Severity - Dangerous, Save DC13, Attack +7.

THE TREASURE VAULT DUNGEON

Rumours of a dungeon packed to the rafters with fantastic treasures has reached the town. Many have tried to plunder it's vaults, but very few ever return to confirm its existence. Time to get those lock picks clean again. Let's go adventuring.

2.7 DUNGEON DOOR TYPE AND PROPERTIES

1d20 DOOR TYPE

- 1-7 **Standard Dungeon Door** - Iron, strong (Toughness 20), regular size, no traps, not locked.
- 8-10 **Standard Dungeon Door II** - Wood, strong (Toughness 20), regular size, no traps, not locked.
- 11 **Small Trapped Locked Iron Door** - Iron, Strong (Toughness 20), small size, Sliding bolt and padlock, Spot DC20, Unlock DC10, Sliding bolt and padlock, Spot (obvious), Unlock DC5, Flame Thrower trap, Spot DC5, Disarm DC20, Damage Severity - Dangerous, Save DC15, Attack +7.
- 12 **Large Trapped Locked Iron Door** - Iron, Strong (Toughness 25), large size (Strength DC10 to open), Rim lock (toughness 20), Spot (obvious), Unlock DC20, Cone of Cold trap (see table F1), Spot DC20, Disarm DC10, Damage Severity - Setback, Save DC13, Attack +7.
- 13 **Large Trapped Wood Door** - Wooden, Strong (Toughness 25), large size (Strength DC10 to open), sliding bolt and padlock (Toughness 15), Spot DC10, Unlock DC15, Lightning Bolt trap, Spot DC15, Disarm DC15, Damage Severity - Dangerous, Save DC15, +8 Attack.
- 14 **Locked Wood Door** - Wooden, Strong (Toughness 20), regular size, Sliding bolt and padlock (Toughness 15), Spot (obvious), Unlock DC10, damp, Knock-knock engraved in Elvish.
- 15 **Giant Barred Iron Door** - Iron, Strong (Toughness 33), giant size (Strength DC15 to open), barred, missing it's handle (needs unlocking DC10), charred marks.
- 16 **Trapped Wood Door** - Wooden, Strong (Toughness 20), regular size, Steel Maw trap (see table F1), Spot (obvious), Disarm DC15, Damage Severity - Deadly, Save DC19, Attack +11.

2.7 DUNGEON DOOR TYPE AND PROPERTIES (CONT)

1d20 DOOR TYPE

- 17 **Arcane Locked Stone Door** - Stone, Strong (Toughness 33), regular size, barred, Arcane Lock (DC15 to dispel).
- 18 **Barred Wood Door** - Wooden, Strong (Toughness 23), regular size, Barred.
- 19 **Giant Trapped Silver Door** - Silver, Strong (Toughness 33), giant size (Strength DC15 to open), Barred, Teleporter Crystal trap, Spot DC20, Disarm DC30, Damage Severity - Deadly, Save DC17, Attack +10.
- 20 **Trapped Gold Door** - Gold (Strength DC10 check to open), Armoured (Toughness 25), regular size, Sonic Attack trap (see table F1), Spot DC5, Disarm DC20, Damage Severity - Deadly, Save DC18, Attack +11.

2.8 SPECIAL DUNGEON DOOR TYPE AND PROPERTIES

1d20 SPECIAL DOOR TYPE

- 1-4 **False Iron Door** - Iron, Armoured (Toughness 25), regular size, False door (cannot be broken through, Spot DC10), Rusty.
- 5-8 **Secret Wooden Door** - Wood, Strong (Toughness 20), regular size, Secret Door, Spot DC15, Open DC10, recently repaired.
- 9-12 **Sliding Stone Door** - Stone, Strong (Toughness 15), regular size, Sliding Door (Strength DC20 for sliding), cracked right through it.
- 13-16 **Platinum Portcullis** - Platinum, Strong (Toughness 20), regular size, Portcullis (Strength DC20 to lift), slightly short door with half inch gap at bottom.
- 17-20 **Iron Door Mimic** - Iron, Armoured (Toughness 25), regular size, Mimic (see Appendix H: Monsters), door handle and frame made from wood.

Design Notes:

- All doors are strong (Toughness 20) or tougher.

THE VOLCANO DUNGEON

A fire giant has recently tightened her grip over the local towns and villages. She plans to own all their wealth. So the villagers and townsfolk have gathered together what little they have left to hire a band of adventures to foil her plans.

2.9 DUNGEON DOOR TYPE AND PROPERTIES

1d20 DOOR TYPE

- 1-7 **Standard Dungeon Door** - Stone, undamaged (Toughness 20), large size (Strength DC10 to open), no traps, not locked.
- 8-10 **Standard Locked Dungeon Door** - Stone, undamaged (Toughness 20), large size, Sliding bolt and padlock (Toughness 15), Spot (obvious), Unlock DC10.
- 11 **Locked Wooden Door** - Wooden, undamaged (Toughness 18), regular size, barred, Arcane lock (+10 Toughness, DC15 to dispel), Sliding bolt and padlock (Toughness 15), Spot (obvious), Unlock DC30.
- 12 **Giant Trapped Iron Door** - Iron, Undamaged (Toughness 25), giant size (Strength DC15 to open), Explosive Fireball trap (see table F1), Spot (obvious), Disarm DC5, Damage Severity - Deadly, Save DC16, Attack +9.
- 13 **The Door of Doh's Reach** - See Legendary Deadly Dungeon Doors in Appendix E!
- 14 **Jammed Stone Door** - Stone, undamaged (Toughness 15), regular size, Jammed (Strength DC15 to open).
- 15 **Iron Door** - Iron, undamaged (Toughness 15), regular size, melted patches, scratched unlocked sliding bolt lock on opposite side of door, Spot DC10, Unlock DC20 (when locked).
- 16 **Giant Crystal Door** - Crystal, undamaged (Toughness 20), giant size (Strength DC15 to open), charred marks, minor fractures.
- 17 **Giant Crystal Door** - Crystal, strong (Toughness 25), giant size (Strength DC15 to open), Falling block trap (see table F1), Spot DC25, Disarm DC25, Damage Severity - Dangerous, Save DC12, Attack +6.

2.9 DUNGEON DOOR TYPE AND PROPERTIES (CONT)

1d20 DOOR TYPE

- 18 **Giant Armoured Wood Door** - Wooden, Armoured (Toughness 33), giant size (Strength DC15 to open), Barred, Sliding bolt and padlock (Toughness 15), Spot DC5, Unlock DC15.
- 19 **Giant Trapped Stone Door** - Stone, Strong (Toughness 30), giant size (Strength DC15 to open), recently repaired.
- 20 **Wooden Door** - Wooden, undamaged (Toughness 15), large size (Strength DC10 check to open), Broken throwing axe embedded into the now split wooden door frame.

3.0 SPECIAL DUNGEON DOOR TYPE AND PROPERTIES

1d20 SPECIAL DOOR TYPE

- 1-4 **Large Locked Secret Wooden Door** - Wood, undamaged (Toughness 20), large size (Strength DC10 check to open), Secret door, Spot DC20, Open DC15.
- 5-8 **Hidden Ivory Door** - Ivory, undamaged (Toughness 15), regular size, Hidden Door, Spot DC25, hidden behind a tapestry on the wall.
- 9-12 **The Sun Journey Door** - See Legendary Deadly Dungeon Doors in Appendix E!
- 13-16 **False Stone Door** - Stone, undamaged (Toughness 15), regular size, False Door (cannot break through, Spot DC10), Pock marks, Has a slightly higher than usual threshold, Painted blue.
- 17-20 **Hidden Iron Door** - Iron, Armoured (Toughness 25), regular size, Hidden Door, Spot DC20, hidden behind a bookcase, melted patches.

Design Notes:

- All standard doors are large.
- +5 to rolls for size of doors elsewhere - Table A4.

IS IT GAME NIGHT YET?

HELLISHLY CREEPY ONE-SHOT
ADVENTURES



FIND US @[DreadfulDungeon](https://www.dreadfuldungeons.com)



Dreadful Dungeons

APPENDIX A - RANDOM DOOR FLOWCHART

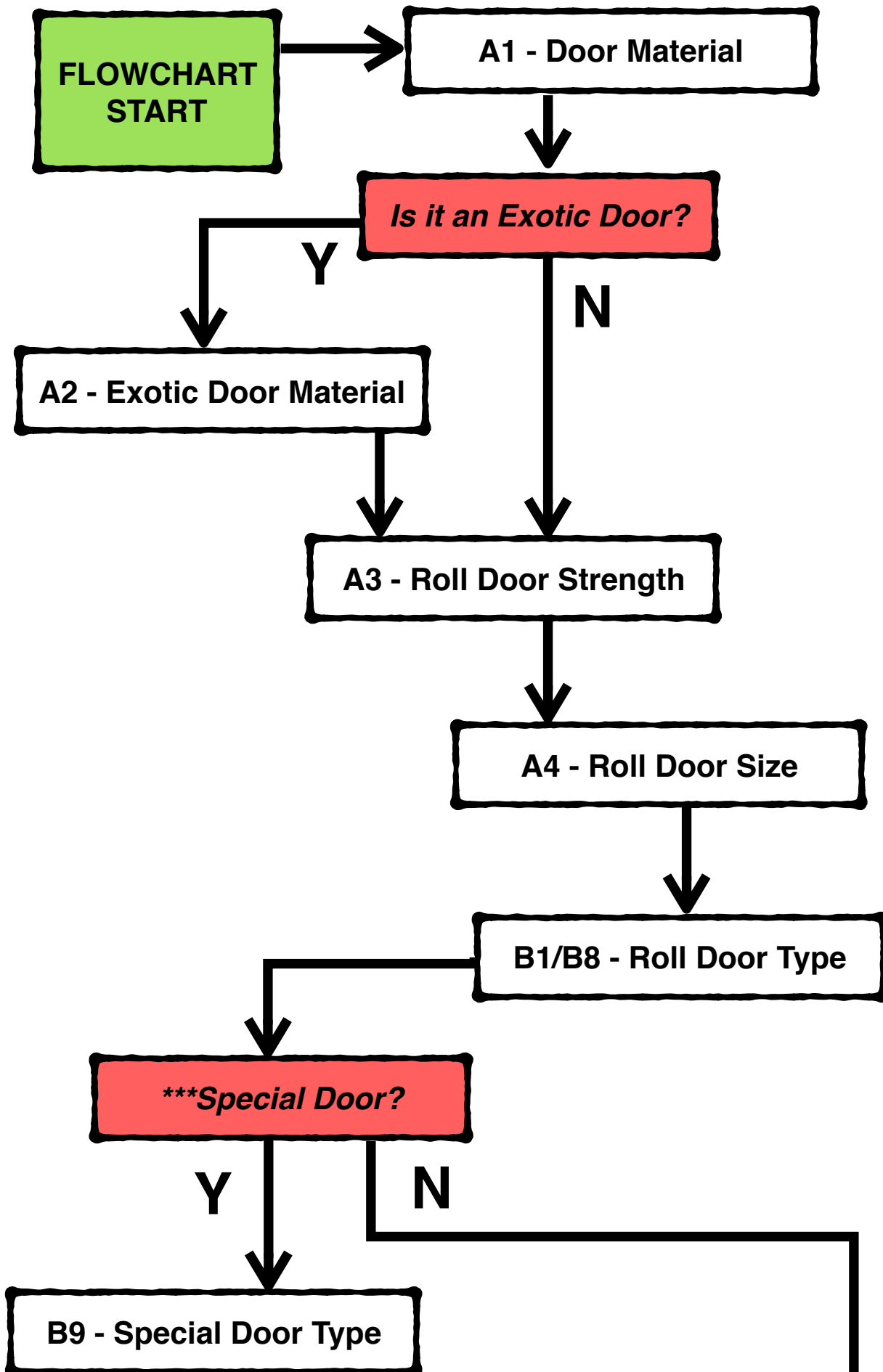

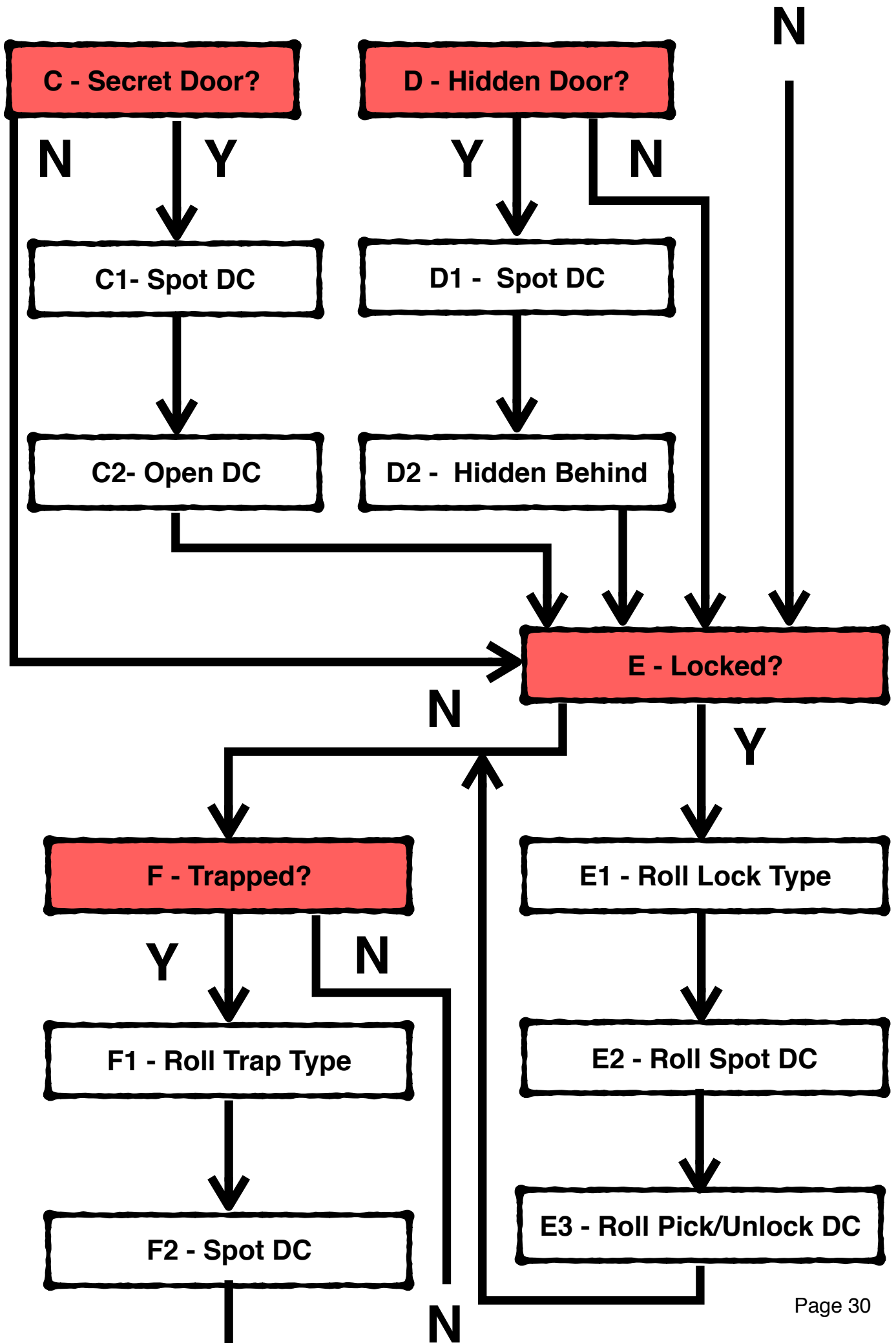

F3 - Disarm DC

F4 - Damage Class

F5 - Escape/Save DC

G - Would you like a Door Oddity?

G1- Roll number of Oddities

Have you got at least one?

G2 - Roll Type of Oddity(s)

THE END....

N

N

Y

Appendix B. DOOR RECORD SHEET I

Door Name / Location:

Material:

Initial Toughness (AC):

Size:

Secret Door:

Spot DC:

Open DC:

Hidden Door Type:

Spot DC:

Lock Type I:

Spot DC:

Pick/Unlock DC:

Lock Toughness (AC):

Lock Type II:

Spot DC:

Pick/Unlock DC:

Lock Toughness (AC):

Trap Type I:

Spot DC:

Disarm DC:

Damage Class:

Escape/Save DC:

Trap Type II:

Spot DC:

Disarm DC:

Damage Class:

Escape/Save DC:

Oddity/Special Features:

- 1.
- 2.
- 3.

Notes (Bars / Jammed etc):

Hit Points

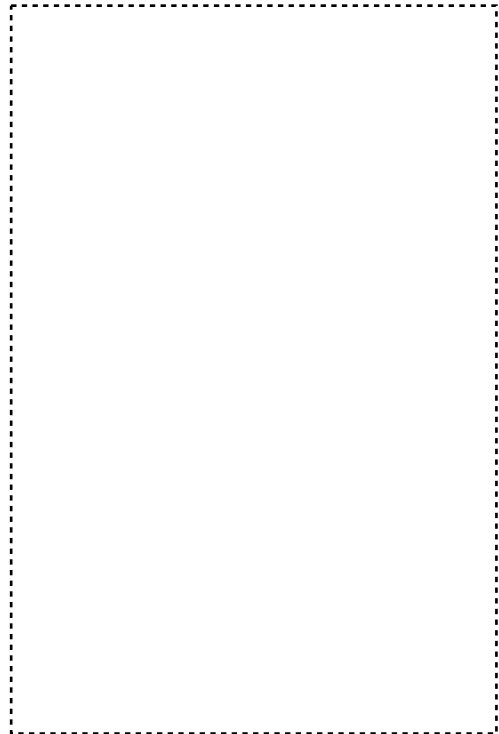

Door Sketch

(for the arty farty)

Send me your designs! I'll update
and publish them

@DreadfulDungeon ;)

Appendix C. DOOR RECORD SHEET II

Door Name / Location:

Material:

Initial Toughness (AC):

Hit Points

Size:

Secret Door:

Spot DC:

Open DC:

Hidden Door Type:

Spot DC:

Lock Type I:

Spot DC:

Pick/Unlock DC:

Lock Toughness (AC):

Lock Type II:

Spot DC:

Pick/Unlock DC:

Lock Toughness (AC):

Trap Type I:

Spot DC:

Disarm DC:

Damage Class:

Escape/Save DC:

Trap Type II:

Spot DC:

Disarm DC:

Damage Class:

Escape/Save DC:

Oddity/Special Features:

- 1.
- 2.
- 3.

Notes (Bars / Jammed etc):

Door Name / Location:

Material:

Initial Toughness (AC):

Hit Points

Size:

Secret Door:

Spot DC:

Open DC:

Hidden Door Type:

Spot DC:

Lock Type I:

Spot DC:

Pick/Unlock DC:

Lock Toughness (AC):

Lock Type II:

Spot DC:

Pick/Unlock DC:

Lock Toughness (AC):

Trap Type I:

Spot DC:

Disarm DC:

Damage Class:

Escape/Save DC:

Trap Type II:

Spot DC:

Disarm DC:

Damage Class:

Escape/Save DC:

Oddity/Special Features:

- 1.
- 2.
- 3.

Notes (Bars / Jammed etc):

APPENDIX D - GLOSSARY OF DOORMINOLOGY

The secret we should never let the gamemasters know is that they don't need any rules.
- Gary Gygax

KNOWLEDGE IS POWER

Contained within this glossary are the in depth rules or ideas you may have missed; and all cross-referenced with the PHB/DMG/MM where appropriate. Warning, this list is NOT in alphabetical order. It's a short list though, and ordered by level of general importance.

If you ever get stuck during a random door generation or cloudy about the rulings for dealing with doors, door locks and door traps then come here.

STORY TELLING

Many of the elements of a randomly generated door will provide you, the DM, with material to improvise with. The newly detailed doors give 'colour' to a normally uninteresting dungeon landscape. They take adventurers by surprise and may promote some strange behaviour from them.

You have been warned. These door could become red herrings, wild-goose chases or false alarms. However, some doors sit there unassuming... with the most deadliest of secrets hidden under it's surface.

As a DM, have fun with the descriptions.

GLOSSARY

Term	Description & Rules	D&D 5e References
Traps	<ol style="list-style-type: none"> All door traps in this supplement are listed in Chapter 3 on table F1 Traps must be 'spotted' before they can be disarmed. Each trap has a Spot DC which requires a successful Passive Wisdom or Wisdom (Perception) check. The Spot DC's of each trap can be found in table F2 of Chapter 3. Once spotted, then a trap requires disarming. This is carried out in 2 steps. The first step is investigating the nature of the trap. Disarm DC's are found in table F3. For this skill check a player needs to roll a check against Intelligence (Investigation) or Arcana in the case of magical traps). Once they have the nature of the trap, they could disarm it without any further checks by good thinking or roleplaying. If a player cannot think of a foolproof way to disarm without a skill check, then they must roll a Dexterity skill check to disarm it safely. A failed check may trigger the trap. Once a trap is triggered and a character is about to feel it's effects a final Save roll can be made. The Save DC's can be found in tables F5.1 to F5.3. But before the damage or save DC can be determined, a roll on table F4.1 to F4.3 to find how severe the damage maybe. This is called Damage Severity, and is a function of the level of the party checking for traps. 	DMG p.120, p. 297. PHB p. 154.
Difficulty Class (DC)	<ol style="list-style-type: none"> Difficulty Class is a number which is used to determine a roll (on 1d20) which is required to match or exceed in order to successfully pass an ability, skill or save roll. Calculating the value of this number is well described in both the Players Handbook and Dungeon Masters Guide. 	PHB p. 7. DMG p.238, p.239.

GLOSSARY

Term	Description & Rules	D&D 5e References
Locks	<ol style="list-style-type: none"> All door locks in this supplement are listed in Chapter 3 on table E1 Locks must be 'spotted' before they can be unlocked/picked. Each lock has a Spot DC which requires a successful Passive Wisdom or Wisdom (Perception) check. The Spot DC's of each trap can be found in table E2 of Chapter 3. Once spotted/identified, then a lock may require picking/unlocking. Unlock DC's are found in table E3. For this skill check a player needs to roll a check against Dexterity. A locks Toughness is also it's Hit Points. 	DMG p.103. PHB p.154,
Armour Class	<ol style="list-style-type: none"> Armour Class is a number which is used to determine how tough and how difficult it is to hit a creature/door is. Calculating the value of this number is well described in both the Players Handbook and Dungeon Masters Guide. This supplements new Toughness stat replaces Armour Class for doors. See Toughness. 	PHB p.7, p.14, p.144, p.177.
Toughness	<ol style="list-style-type: none"> This a new mechanic used to describe the over all Toughness and 'weight' of a particular door. Each door has a Toughness figure and can be found on the Dungeon Door Strength Table A3 in Appendix A. A doors Toughness can be increased or lowered during it's random generation by things like it's size, material type and defects. Toughness also represents it's total Hit Points. When hit points reach 'zero', then the door is destroyed. 	
Size	<ol style="list-style-type: none"> Door Size can be determined during it's creation on table A4 in Appendix A. A small or regular sized door has no additional effects. A large door requires pushing open with a Strength (Athletics) check with a DC10. It also increases in toughness by +5. A giant door requires pushing open with a Strength (Athletics) check with a DC15. It also increases in toughness by +10. 	
Material	<ol style="list-style-type: none"> A door's Materials can be determined during it's creation on table A1 and A2 in Appendix A. Some materials have a maximum or a minimum toughness. This is applied AFTER rolling the doors toughness on table A3. This means that further augmentation can happen due to size and/or special attributes. Each material has it's own resistances, vulnerabilities and invulnerabilities. They are listed in their own glossary entry. 	
Wood	<ol style="list-style-type: none"> Wooden Doors have no special resistances. Wooden doors are invulnerable to the following damage type: poison. They have a maximum toughness of 20. 	
Iron	<ol style="list-style-type: none"> Iron Doors are resistant to the following damage types: lightning, fire. Wooden doors are invulnerable to the following damage type: poison. They have a minimum toughness of 10. 	
Bone / Ivory	<ol style="list-style-type: none"> Bone/Ivory Doors have no special resistances. Bone doors are invulnerable to the following damage type: poison. They have a maximum of 15 Toughness. 	

GLOSSARY

Term	Description & Rules	D&D 5e References
Stone	<ol style="list-style-type: none"> 1. Stone Doors are resistant to the following damage types: lightning, fire, cold, slashing, piercing. 2. Stone doors are invulnerable to the following damage type: poison. 3. Stone doors can be brittle and therefore are vulnerable to the following damage types: force, thunder. 4. They have a minimum toughness of 10. 	
Gold/Silver/ Platinum	<ol style="list-style-type: none"> 1. G/S/P doors are heavy and require a Strength (Athletics) check with a DC10 to open. 2. G/S/P Doors are resistant to the following damage types: lightning, fire, psychic. 3. G/S/P doors are invulnerable to the following damage type: poison. 4. They have a min toughness of 15. 5. Jammed doors have a min DC20 to open. 	
Mithral	<ol style="list-style-type: none"> 1. Mithral Doors are resistant to the following damage types: lightning, fire, psychic, necrotic, radiant. 2. Mithral doors are invulnerable to the following damage type: poison. 3. They have a min toughness of 20. 4. +5 to toughness. 	
Adamantine	<ol style="list-style-type: none"> 1. Adamantine Doors are resistant to all damage types. 2. Adamantine doors are invulnerable to the following damage type: poison. 3. They have a min toughness of 25. 4. +10 to toughness. 	
Material	<ol style="list-style-type: none"> 1. A door's Materials can be determined during it's creation on table A1 and A2 in Appendix A. 2. Some materials have a maximum or a minimum toughness. This is applied AFTER rolling the doors toughness on table A3. This means that further augmentation can happen due to size and/or special attributes. 3. Each material has it's own resistances, vulnerabilities and invulnerabilities. They are listed in their own glossary entry. 	
Themematic	<ol style="list-style-type: none"> 1. This is a term applied to elements of the dungeon which fit with the natural 'theme' of the dungeon. For example: stone doors in a stone mine, or perhaps crystal doors in an ice dungeon. 	
Feedback	<ol style="list-style-type: none"> 1. Please send all feedback to us @DreadfulDungeon on Twitter or avatar.ieng@gmail.com 	
Exotic Materials	<ol style="list-style-type: none"> 1. They are rare materials used in the construction of doors. They are found on table A2 in Chapter 3. 	
Jammed Door	<ol style="list-style-type: none"> 1. Some doors swell up or rust/warp and become jammed in the frame. 2. To move a jammed door, take the Toughness of the door and use this as the DC to roll a Strength (Athletics) check against. 	
Barred Doors	<ol style="list-style-type: none"> 1. Barred doors have a single flat bar made from the door material or iron on the reverse side of it. It can be removed easily by lifting it from it's braces. 2. A barred door has a +3 to Toughness to represent it's new enhanced sturdiness. 	

GLOSSARY

Term	Description & Rules	D&D 5e References
Sliding Door	<ol style="list-style-type: none"> 1. A sliding door rolls back and forth on casters or a rail in the floor. 2. It requires a Strength (Athletics) check using the door's toughness as the DC to slide open. 	
Portcullis	<ol style="list-style-type: none"> 1. A portcullis door operated by raising up and lowering down. Quite often, they are counter balanced with weights - which lower the difficulty in moving them. 2. It requires a Strength (Athletics) check using the door's toughness as the DC to lift them up. They drop back down in a single turn if dropped. 	
False Door	<ol style="list-style-type: none"> 1. A false door is simply that, a small amount of fake material attached to the face of a wall or floor and disguised to look like a fully operational door. 2. They cannot be broken through like a door. They can only be broken through as a wall. 3. Each false door can be spotted when up close with a Spot DC10 (see Spotting Traps/Locks). 	
Hidden Door	<ol style="list-style-type: none"> 1. Hidden doors are doors obscured by another object in a room. 2. You can try to find a hidden door by being close and rolling the Spot DC as found in table D1 in Chapter 3. 3. The object which obscures the door can also be rolled on table D2, Chapter 3. 4. A hidden door is 'found' by moving the object obscuring it. Then it becomes a normal door. 	
Secret Door	<ol style="list-style-type: none"> 1. Secret doors are disguised to look like the wall/floor/ceiling of the room in which they are found. 2. The door is made from the same material as rolled when first generating it and NOT the same material as the wall - unless the DM wishes it. 3. A secret door can be 'spotted' using the Spot DC as detailed in table C1, Chapter 3. 4. Once spotted, a secret door usually also has a 'secret' way to open it. The difficulty to discover this, also known as the Open DC, is found on table C2, Chapter 3. 	



GLOSSARY

Term	Description & Rules	D&D 5e References
Mimic Door	1. HAHHAHAHAHAH!!! See Appendix H: Monsters for more information.	MM p.220.
Arcane Lock	1. An Arcane Lock spell has enchanted the door. 2. +10 to the toughness of the door, and it is unable to be opened unless it is broken through or the magic is dispelled. 3. Dispelling the Arcane Lock lasts for 10 minutes.	PHB p.215.
Damage Severity	1. Each door trap has set amount of damage it can do in a single 'attack' or turn. 2. To find the severity of the damage, refer to tables F4.1 to F4.3. Dependant on the level of the adventuring party.	PHB p.7, p.12, p.179, p.205.
Save DC	1. Each door trap has a set difficulty class (DC) should an adventurer be caught off guard and sets off the trap. This value can be found on tables F5.1 to F5.3.	PHB p.7, p.12, p.179, p.205.
Door Oddities	1. These are special characteristics of doors which may or may not have any thematic or adventuring meaning. Kind of like a red herring, but they provide an endless source of fun and embellishment to roleplaying.	
Passive Perception	1. Passive Perception is 10 + Wisdom modifier + Proficiency Bonus (if you have the Perception skill). 2. If a Lock or Trap's Spot DC is lower than a characters Passive Perception, then they can be fed all the information relevant without a spot check.	PHB p.178.
Wisdom (Perception)	1. Wisdom (Perception) is a skill check against a Difficulty Class as set by the DM or by the trap/lock which is being searched. 2. This skill check takes a whole ACTION and must be instigated by the character wanting to search.	PHB p.178.
Uncanny Dodge (Rogue)	1. This ability allows Rogues to halve all damage from an attack which they can see. The same applies to damage from traps which cause physical damage.	PHB p.96.



APPENDIX E - LEGENDARY DUNGEON DOORS

Heroes Get Remembered,
Legends Never Die”
- Four Year Strong

PSSSST...

“Who’s that?”

- “Oh he’s that adventurer who survived the dungeon in Whattle Keep... well most of him did anyway.”

“Wow... his comrades must have really loved him to drag his body back to the Inn looking like that!”

- “What? No! HE is all that’s left of his group.”

“How did he get back to the Inn looking like *that?!?*”

- “No one’s sure, but it’s believed that what’s left of him crawled across the Plain of Deelia to reach us...to deliver a message.”

“Dwarves eh!? Why didn’t he just die like anyone else? What a way to live out the rest of your years.”

- “Apparently when he was finally able to speak he began telling the Inn’s patrons about the dungeon they were defeated by... and a single door. One nightmarish door - he described it as an alcove of 7 deaths, or lady pain...?”

“THE LADY OF SEVEN PAINS?!”

- “Yes, I think that’s the door-? Why?”

“Stories have been told of a dungeon door so torturous, so evil that it is said that it’s origins are otherworldly, godly even. But I didn’t know where it resided. So... the legendary, unbeatable door of torture exists... and it’s on our very doorstep! We have to see it in person, we must to test ourselves!”

- “Fine. What’s the worst that can happen?...”

PIÈCE DE RÉSISTANCE

So at long last, we have reached the end game, the end of level boss fight. The following **Legendary Deadly Dungeon Doors** (LDDD’s) are the reasons why we really created this supplement.

If you ever choose to use one of these doors in your adventure or find yourself facing off against one as an adventurer, then we’d love you to tell us what happened on @DreadfulDungeon.

Each LDDD has a history and a very potent set of rules to follow, as they cannot be accidentally rolled in the tables of Chapter 2, Random Dungeon Doors. We hope you’ll love reading all about them and perhaps even have a go at designing one yourself.

ROLL A LEGENDARY DOOR

1d20	Door Type
1-2	The Thief is a Traitor!
3-4	The Door of Doh’s Reach
5-6	The Door Yonder
7-8	The Sun Journey Door
9-10	The Dancing Door
11-12	The Eel Tank
13-14	The Entertainer, Bards Door.
15	Merrshaulk’s Portcullis
16	The Druid Door
17	Skin of Sin
18	Elaacriminalicros’s Halfling Door *
19	The Beholdoor *
20	Door to the Star People

* These doors were designed by the winners of our **Deadly Dungeon Doors Competition** - *Joseph Michael Stash III & Paul Brown.*

THE THIEF IS A TRAITOR!

It's a TRAP!"
- Admiral Akbar

Legend has it that there once was wizard who had been betrayed and stabbed in the back by a thief in her adventuring party. After only just escaping with her life she began building a tower to protect her treasures. Forming the front line of the magical defences was a door she nicknamed 'The Thief is a Traitor!'. Which is said to be inscribed into the face of it's stone threshold.

Material: Strong Wooden

Toughness (AC): 23 (20+3)

Hit Points:23 (20+3)

Size: Regular

Lock I: Barred from other side of door (+3 Toughness)

Lock II: Mortice lock (Toughness 25), **Spot DC15, Unlock DC20.**

Trap: Magic Missiles (red, see damage table) are fired from the key stone above the door at the creature furthest from the door (max range 80 ft), **Spot DC15** will reveal that by stepping onto the threshold a pressure plate (20lbs or more) will trigger *something*. A successful **Intelligence (Arcana) DC10** check will then reveal the the keystone above the door is linked and faintly magical. Also a successful **Intelligence (Investigation) DC20** check will reveal that by 'spiking' the plate on the right-hand edge only will prevent it from triggering. If a player spikes the plate, ask them where they are doing it. Dispeling the trap will work using a **Disarm DC15** and will last for 1d10 turns. Spiking the plates uses



the same disarm DC on a **Dexterity (Acrobatics)** check. An unsuccessful dispel or attempt to spike the plate will set the trap off immediately. Rolling a successful **Save DC16** will reduce the damage by half. OR if the creature is able to cast the **Shield** spell then no damage is done... HOWEVER the next time this creature casts the **Magic Missile** spell it will automatically target the nearest target (friend or foe).

DAMAGE

Level Damage Severity - Deadly

1-4 4d10 force damage (4 missiles)

5-10 10d10 force damage (10 missiles)

11-16 18d10 force damage (18 missiles)

17-20 24d10 force damage (24 missiles)

THE DOOR of DOH'S REACH

The executioner's face is always well hidden."
- Bob Dylan

Legend has it that a portal to the nightmare dimension of 'Doh' the collector demon was made permanent by a mad Warlock. If the rumours are true, then this dimension would surely contain some of the world's most powerful and sought after treasures.

No one knows exactly where the portal was sited. Perhaps it doesn't even exist at all. But keep an eye out anyway... you never know.

Material: Strong Iron (window opening, obscured by iron bars)

Toughness (AC): 20

Hit Points: 20

Size: Regular

Lock: Rim lock on opposite face of door (Toughness 20), **Spot DC15, Unlock DC15.**

Trap: Electric Shock Trap (see Damage Table for damage and Save DC). If a **Spot DC15** is passed then charred skin pieces will be found on the door handle and the smell of ozone and burnt hair is in the air. A successful **Spot DC20** also reveals skin bits on the door.

Touching the door anywhere whilst standing on the metal grate will trigger the trap. If the trap is spotted, then an **Intelligence (Arcana)** check with **DC15** will reveal a faint magical connection between the door and metal grate in the floor. An **Intelligence (Arcana) DC20** check will also reveal that the pit under the grate appears to be magically darkened/obscured and possibly a portal to another dimension. Disarming the trap can be done using **Dispel** with **DC20** and lasts for 1d10 rounds.



Also, an adventure who only touches the door, will not trigger the trap. For example: using levitate, mage hand or building some kind of ad-hoc bridge to insulate them. If the trap is triggered then a **Constitution** save is allowed (see Damage Table) to halve the damage. Once a shock happens, then the creature is forced to drop whatever object(s) they hold or save against a **Dexterity (Acrobatics)** check. If the object(s) dropped are less than 12 inches long and 3 inches wide then the object(s) are lost down the pit. If the object is longer then it has a 25% chance of dropping into the pit. If the object(s) are wider than 3 inches then they just fall onto the grate. The pit is a portal to a pocket dimension.

DAMAGE TABLE

Level	Damage Severity - Setback
1-4	1d10 lighting damage, Save DC16
5-10	2d10 lighting damage, Save DC18
11-16	4d10 lighting damage, Save DC20
17-20	10d10 lighting damage, Save DC25

THE DOOR YONDER

When people show you who they really are, then believe them.”
- Maya Angelou

Legend has it that a goddess named Yondalla who was considered both good and virtuous had a darkness in her past. Before she become the goddess she is known for, she was a halfling. It took many years for her to truly understand why no one would take her seriously in her mortal form. As soon as she ascended to walk alongside the gods; she cursed 12 doors as a parting gift to all mortals.

It was said that each door cursed would take revenge on any mortal who took themselves too seriously...

Material: Wood

Toughness (AC): 25 (15+10)

Hit Points: 25

Size: Small

Lock: Arcane Lock (+10 Toughness, Dispel DC15). Spot DC10 (Arcane/Intelligence), Unlock DC15 (Dispel)

Trap: ‘A Day in the Life of’ Trap (see Save Table for Save DC). If a **Spot DC15** is passed then small chop marks can be seen on the frame only. If the chop marks are spotted, then an **Intelligence (Investigation)** check with **DC15** will reveal that the chop marks do not seem to align with marks on the door, which looks less aged than the frame. Dispelling the Arcane Lock with **DC15** and lasts for 1d10 rounds.

If however the adventurers cannot unlock the door using magic, and choose to bash through the door then this triggers the trap. The first creature to step through the door after it’s destruction will need to succeed with a **Save** or be transformed into one of the creatures in the TRANSFORMATION TABLE for 24 hours. This trap turns the creature into a normal



creature with no character class abilities (see the MONSTER MANUAL). The creature transformed retains its alignment, its Intelligence, its saving throws, and its hit points. It does not gain any bonuses that are offered by the creature it has become. A creature transformed by ‘a day in the life of’ cannot cast spells, although these are not forgotten and can be cast when the creature once again assumes its normal form. Once the 24hrs have passed, the door magically regenerates itself in the same door frame and acts just as before.

TRANSFORMATION TABLE

1d6	Creature Transformed into
1-3	Halfling (re-roll if already one)
4	Gnome (re-roll if already one)
5	Goblin (re-roll if already one)
6	Kobold (re-roll if already one)

SAVE TABLE

Level	Saving DC
1-4	Save DC16 (Charisma or Wisdom)
5-10	Save DC18 (Charisma or Wisdom)
11-16	Save DC20 (Charisma or Wisdom)
17-20	Save DC25 (Charisma or Wisdom)

THE SUN JOURNEY DOOR

Some days you just have to create your own sunshine.”
- Unknown

Not all legends and doors were ever meant to be. But when the Clerics of Pelor; the sun god, built a mechanically locked access door to their most secret chambers in their temples, they never thought that a gnomish artificer would steal their idea and pervert it for his amusement.

There are some Clerics of Pelor who are so offended with the creation of this magical abomination that they seek out the whereabouts of it at any cost. They send bands of adventurers to destroy them. “Do not engage with the door, it is an abomination ...destroy it before it destroys you!”

Material: Stone (armoured)

Toughness (AC): 25

Hit Points: 25

Size: Regular

Lock: Moving the glowing door knob to the right slots in the right combination unlocks the door. A successful **Intelligence (Investigation) DC20** will reveal the first 2 locations to move the door handle to via recognising a pattern in the wearing on the stem of the door knob.

Trap: Combination Lock Trap (see Damage Table for damage and Saves). The combination for this trap is 1, Sun(4), 6, Sun(4). When shifting the door handle forwards it will not progress past the first vertical slot until either position 1 or 2 is chosen. When the right choice is made (1) then position 2 is blocked-off, allowing access to positions Sun(4) and 3. Access to positions 5 and 6 are blocked off until either Sun(4) or 3 is chosen. Then once the right choice is made (Sun) the door knob has access to the final 2 slots and blocks off going backwards again. Finally when the right final slot is chosen (6) then the sun glows and all the other slots are

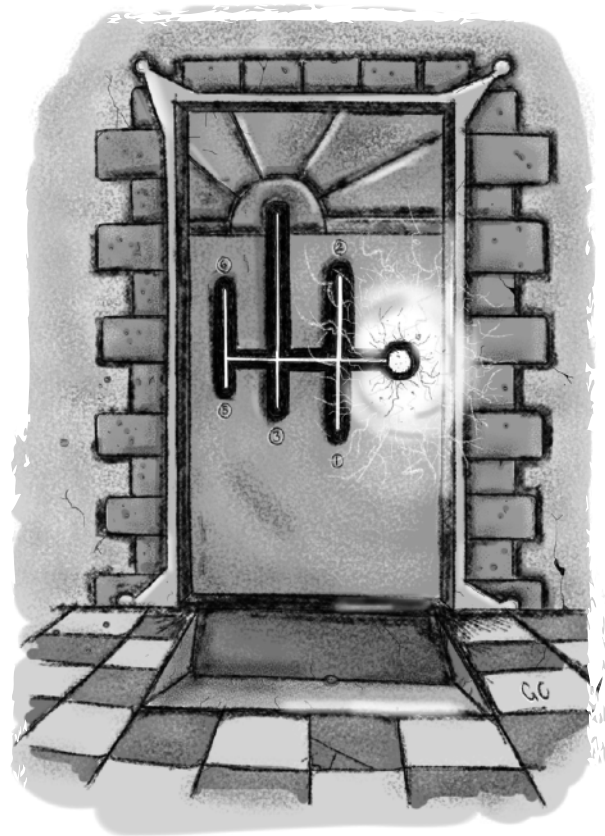

available for choosing. The door handle must be put back into the sun position once more to open the door.

If at anytime, the wrong slot is selected at the wrong time then the following will occur AND the lock and handle will both reset back to where they began:

- Slot 1 - Necrotic Damage (see Table)
- Slot 2 - Fire Damage (see Table)
- Slot 3 - Cold Damage (see Table)
- Slot 5 - Psychic Damage (see Table)

Damage envelops a creature as though being bathed in a light resembling the damage type. A successful Constitution save halves the damage.

DAMAGE TABLE

Level	Damage Severity - Dangerous
1-4	2d10 damage, Save DC12
5-10	4d10 damage, Save DC13
11-16	10d10 damage, Save DC14
17-20	18d10 damage, Save DC15

THE DANCING DOOR

Are we having fun yet?"
- Bill Griffith

The existence of these doors throughout the dungeons of Faerun is a well documented phenomena. Even though they were never considered a particularly deadly door, they were still feared by all who faced them.

The first rule of most successful adventuring parties is "Never split the party.". The second rule is "Never take on a Dancing Door alone."

Material: Wood (strong)

Toughness (AC): 20

Hit Points: 20

Size: Large

Lock: A mortice lock (Toughness 20) protects this door from opening which is obvious to spot. **Unlock DC20.**

Trap: Revolving Door trap (see Damage Table for damage and saves). **Spot DC12** to spot scratches and scuff marks on the semi-circular threshold. An **Intelligence (Investigation)** check with **DC14** is required to determine that the door appears to pivot (rotate) about a central axis. A revolving door. A **Spot DC20** will also reveal that the door is sprung-loaded along with a lock resetting system. A higher **Intelligence (Investigation)** roll with check **DC20** will tell the creature that the whole door and mechanism is trapped to spin once unlocked. Jamming the door in the frame as it spins appears to be the only way to prevent the door from re-locking itself OR by disarming the mechanism with a **DC15 Dexterity** check. If a creature triggers the trap then they are allowed a **Dexterity Save** using the DC as on the Damage Table.

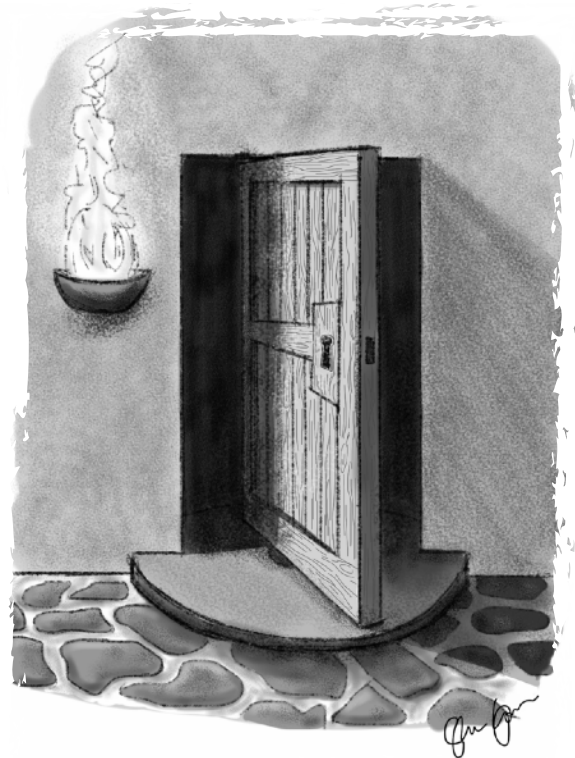

A successful save means that they can attempt to jump free before the door rotates 180 degree and locks them on the opposite side of the door. Jumping free requires a **Dexterity (Acrobatics)** check with same DC. A failed roll and the creature takes full damage AND is trapped between the door frame and the door. A passed check allows the creature to jump free suffering only half the damage, onto either side of the door (their choice).

A creature trapped (grappled) in the door frame requires a **Strength (Athletics)** check to free them or take 1d4 bludgeoning damage each turn they remain there.

When the door completes a 180 degree spin, it immediately re-locks itself.

DAMAGE TABLE

Level Damage Severity - Setback

1-4 1d10 bludgeoning damage, Save DC14

5-10 2d10 bludgeoning damage, Save DC16

11-16 4d10 bludgeoning damage, Save DC18

17-20 10d10 bludgeoning damage, Save DC20

THE EEL TANK

never worry about numbers. Help one person at a time, and always start with the person nearest you.”
- Mother Theresa

The origins of this legendary door can be traced back to a much feared, part-flooded dungeon full of poisonous eels.

It was later said by the wizard who built the original dungeon that the trapped doorways killed more unprepared adventurers than the eels themselves. His deadly legacy continues with these tricky doors to this day.

Material: Wood (strong)

Toughness (AC): 20

Hit Points: 20

Size: Regular.

Trap: Guillotine trap (see Damage table for damage, saving DC and attack bonus). Due to the door's threshold being 3ft above the floor then any checks to spot or disarm this trap are disadvantaged UNLESS the creature is lifted up level with the door somehow. Any creatures less than 4ft tall will not be able to reach the trap mechanism without being lifted up by 3ft. Detecting the trap has a **Spot DC15**, it is well hidden. A failed spot check will still reveal blood dripping down the face of the wall under the door. An **Intelligence (Investigation)** check with **DC16** will reveal that the trap is triggered by climbing onto the pressure sensitive raised door threshold (min 20lbs). Spiking the pressure plate with pitons will disarm the trap with a **Disarm DC12 Dexterity** check. A failed check will set off the trap with no chance of being caught in it.

If a creature is caught in the triggered trap then they will sufferer damage as per the



Damage Table below if the guillotine manages to hit them (use the **Attack** bonus when rolling to hit). A successful **Dexterity** save will halve the damage.

Extra note: Running/jumping through the door requires a successful Dexterity (Acrobatics) check or be knocked prone in the doorway and trigger the trap.

DAMAGE TABLE

Level	Damage Severity - Dangerous
1-4	1d10 slashing dmg, Save DC12, +6 Attack
5-10	2d10 slashing dmg, Save DC13, +7 Attack
11-16	4d10 slashing dmg, Save DC14, +7 Attack
17-20	10d10 slashing dmg, Save DC15, +8 Attack

THE ENTERTAINER, BARDS DOOR

Even the nicest people have their limits.”
- Unknown

Little is known about the origins of this door nicknamed The Entertainer or the Bards Door. Legend has it that it's construction was commissioned by a bards college to train students - without the painful trap of course.

*“Knock knock. Who’s there?
Doris! Doris who?
Doris locked thats why I’m knocking”*

Material: Wood (strong)

Toughness (AC): 30 (20+10)

Hit Points: 30 (20+10)

Size: Regular.

Lock: Arcane Lock (+10 Toughness), Spot DC10 (Arcane/Intelligence), Unlock DC15 (Dispel). The door will not open without engaging with the animated face on the door (see below for details). **This is a roleplaying encounter.**

Trap: If a dispel or ‘knock’ spell is cast on the door, or it’s physically attacked, then the face starts to get **angry** (see below).

Approaching the door from over 20ft away, creatures will see an animated chalky image of a face, crying. Once within a 20ft radius of the door, approaching creatures will be able to hear the door snivelling and crying.

*“Woe is me.... I’m so sad **sobs**”.*

The door needs cheering up, with funny jokes, anecdotes, limericks or stories. The door is to be made **happy** by a combination of the above entertainment. 3 successful **Charisma (Entertainment)** checks in a row must be made for the door to turn his frown upside down and open up wide. Knock-knock jokes get an advantaged roll. Obviously.

An unsuccessful check will depress him and start the happiness level count again.



3 unsuccessful **Charisma (Entertainment)** checks in a row will begin to make the door very **angry**.

The door will know very little about the rooms which follow it, but a successful Charisma check will give the players a fragment of the dungeon’s history, if the DM has it prepared. An **Angry Door** will warn the focus of it’s anger once with *“Well... you’ve made me mad. I double dare you to do it again!”* If a group decides to make him angry again then the nearest creature gets hit with 1 **Scorching Ray** per 1d10 of damage, which shoots from the candle above it’s head (damage as below). Damage is halved with a successful **Dexterity Save**. Making hits with the scorching ray will automatically give the door a single level of happiness as it laughs.

DAMAGE TABLE

Level	Damage Severity - Dangerous
1-4	2d10 fire dmg, Save DC13, +6 Attack
5-10	4d10 fire dmg, Save DC14, +7 Attack
11-16	10d10 fire dmg, Save DC15, +7 Attack
17-20	18d10 fire dmg, Save DC16, +8 Attack

MERRSHAULK'S PORTCULLIS

What was that sound?"
"Sound? What *sound*?"
"EXACTLY! Just..shusshhh..."
- Ini Mettaff (Elven Rogue)

The long lost god of snakes called Merrshaulk sleeps. He no longer demands a blood sacrifice as he became bored of paying attention to all but his most devout followers.

As a tribute to her master, a powerful warlock named Vileshinea wished that Merrshaulk's name be remembered in death. Death by poison and having the life crushed out from inside of you...

Material: Iron Portcullis with Silver Snakes

Toughness (AC): 20

Hit Points: 20

Size: Regular

Description: An iron portcullis adorned with 2 silver ornate snakes. There is no lever and no lock to be seen. From 10ft away, a Wisdom (Perception) check with DC15 will reveal a very quiet hissing sound.

Lock: A Spot check with DC10 will reveal that it is a portcullis which requires lifting. BUT it cannot be lifted until the silver snakes are prised off from the bars, as they impede the bars from moving upwards.

Trap: The trap can be detected using an Intelligence (Arcana) check with a DC12 or by the Detect Magic spell. The faint aura of Transmutation and Conjuraction magic will emanate from the snakes. Any attempt to touch, break or bash the portcullis will bring both the snakes to life! They will drop to the ground, immediately roll for initiative and attack. To proceed past the door, the snakes must be destroyed, then the portcullis will raise for 10 minutes and then close. The 2 snakes will magically reappear on the gate as soon as the gate is closed again.

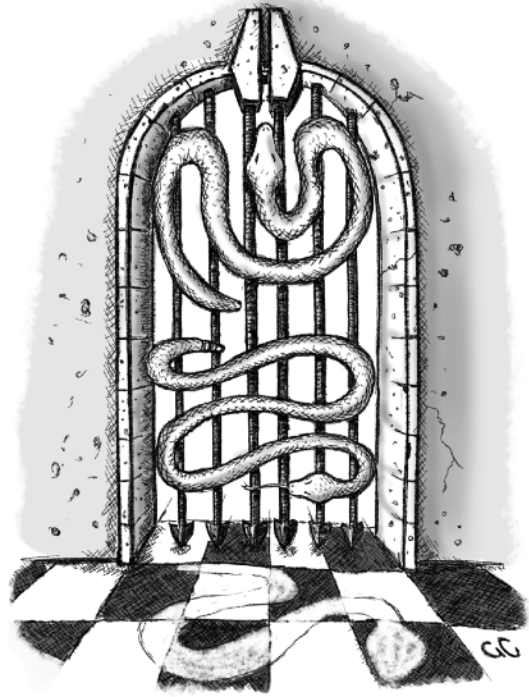

The snakes are a **giant constrictor** and a **giant poisonous snake**. See **Appendix H: Monsters** for their stat blocks.

If Dispel Magic, or Knock are cast on the door, with a DC16, then the trap will be magically disabled for 10 minutes. This also means that the gate can only be raised by an inch with a successful Strength (Athletics) check with a DC30.

The damage caused by each snake is described in **Appendix H**.

Level	Damage Severity - Dangerous
1-4	2d10 poison damage, Save DC12, +6 Attack
5-10	4d10 poison damage, Save DC13, +7 Attack
11-16	10d10 poison damage, Save DC14, +7 Attack
17-20	18d10 poison damage, Save DC15, +8 Attack

THE DRUID DOOR

All you needed to have done is knocked on my door, and I would have let you in..."
- Nereza Sephiran (Dark Druid)

The origins of this legendary door can be traced back to a time when druids were found to be even more secretive than they are now.

It takes powerful magic to keep a druid door's enchantment from not fading over time.

Material: Wood (damaged)

Toughness (AC): 20 (10+10)

Hit Points: 10

Size: Regular.

Description: The door looks weak and damaged. There are roots and branches growing through gaps in the door, and surrounding the portal. No lock or door handle can be seen.

Lock: The door has an Arcane lock (+10 Toughness). A successful Intelligence (Arcane) check with a DC12 will identify the barely noticeable aura of an enchanted door. The door cannot be unlocked without the arcane lock being dispelled first, or Knock/Druidcraft being cast on the door, then it will open it for 10 minutes before closing once again.

Trap: The trap can be detected using a successful Intelligence (Arcane/Nature) check with a DC14. By leaning against the door a PC will notice that some of the roots shift towards them a very small amount. A successful dispel magic with a DC15 will dispel the trap.

If someone tries to break down the door, then grasping vines will reach out and attack any creatures attacking the door for up to 20ft away. It can attack up to 2 creatures at once.



The attack bonus are given below. Once a hit has been successful, then bludgeoning damage is done - halved with a successful Dexterity save. Then a Strength (Athletics) save must be made or the creature is considered 'restrained' and damage is done each turn automatically until a restrained creature has passed the Strength check to escape. If at anytime **Entangle** or **Plant Growth** is cast on the door - use the **DANGEROUS** damage severity table below.

DAMAGE TABLE

Level Damage Severity - Setback

1-4 1d10 bludgeoning damage, Save DC10, +3 Attack

5-10 2d10 bludgeoning damage, Save DC10, +4 Attack

11-16 4d10 bludgeoning damage, Save DC11, +4 Attack

17-20 10d10 bludgeoning damage, Save DC11, +5 Attack

Level Damage Severity - Dangerous

1-4 2d10 bludgeoning damage, Save DC12, +6 Attack

5-10 4d10 bludgeoning damage, Save DC13, +7 Attack

11-16 10d10 bludgeoning damage, Save DC14, +7 Attack

17-20 18d10 bludgeoning damage, Save DC15, +8 Attack

SKIN OF SIN

A ah! Feels like my skin is about to explode.”
- Spawn

Legend has it that a high priest of Orcus name Kyuss plundered corpses to create the much feared 'Spawn of Kyuss'. During this time his temple was under constant attack from treasure seeking, do-good adventurers. Kyuss created this entrance door to his shrine and it is said to have caused an plague of 'Burrowing Worms' in nearby towns and villages. The memory of this much maligned door lives on to this very day.

Material: Bone

Toughness (AC): 15

Hit Points: 15

Size: Regular.

Description: The door appears to have dried and cracked skin, like parchment stretched over a featureless face. The strong odour of rotten flesh is heavy in the air, and a 5ft deep alcove of made of stone welcomes adventures forward to unlock the sliding bolts. To the left of the door is a large glass vial with strange luminescent green liquid in it. A Wisdom (Perception) check with DC15 will reveal 1d3+1 unmoving worms suspended in the vial. A perception roll greater than 20 will reveal that on the opposite stone wall to the glass vial are 4 very small holes drilled into it.

Locks: Their are 2 siding bolt locks which are obvious to see but held shut with padlocks. To Unlock, a successful Dexterity check with a DC15 must be made on each of them. Once unlocked, the bolts will slide back and the door can be pushed wide open.

Trap: The bottom sliding bolt is trapped, once it is slid open, then 4 ball bearings will be fired

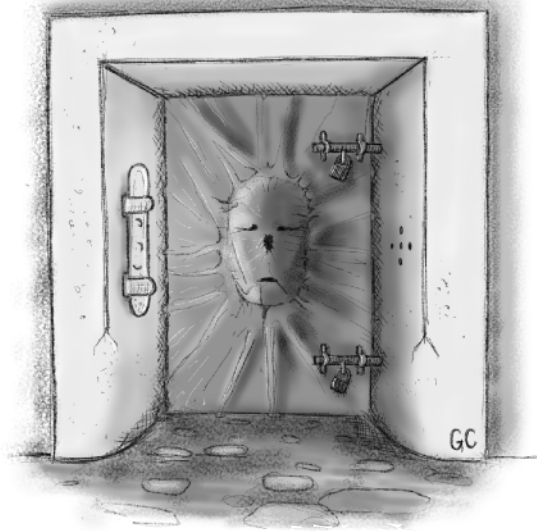

into the glass vial hanging on the wall. The trap can be spotted with a successful Wisdom (Perception) check with a DC20. The trap can be disarmed with a Disarm check of a DC15. A successful Intelligence (Investigation) check with a DC15 will also reveal that the trap will probably trigger something to be fired from the holes (so long as the PC' spotted the holes). They may have the idea to either plug the holes or protect the glass vial from being smashed, which is fine.

If the trap is triggered, then 4 small ball bearings will be fired into the glass vial and smash it open. If the balls hit anyone they cause 1 piercing damage each (as per table below). Once the vial is smashed, roll initiative and have each of the 'Burrowing Worms' attack any creatures within 10ft of the door.

See **Appendix H: Monsters** for more details.

DAMAGE TABLE

Level Damage Severity - Setback

1-4 1 piecing damage, Save DC10, +3 Attack

5-10 2 piecing damage, Save DC10, +4 Attack

11-16 4 piecing damage, Save DC11, +4 Attack

17-20 10 piecing damage, Save DC11, +5 Attack

ELAACRIMALICROS'S HALFLING DOOR

Elaacriminalicros's made a critical error, and the time for our plundering has come."
 - Oedh Springshade, Rogue.

Ensconced safely away in Star Mounts, of High Forest, an ancient green dragon named Elaacriminalicros sleeps. It is said that there is a door to his lair which has been left unguarded for centuries. Even though the door was recently rediscovered by dwarves and sealed off, it still remains by far the easiest way to secretly plunder Elaacriminalicros's vast mountain of treasure.

Many dwarves died to bring us this information...

Material: Stone

Toughness (AC): 21 (20 + 1)

Hit Points: 21 (20 + 1)

Size: Large.

Description: Approaching the door from outside the dragon's lair will reveal only a large strong looking, plain stone door way at the end of a long and rocky passage. There is no door handle and no key hole. A successful Wisdom (Perception) check with DC15 will reveal that the door appears to be barred from the inside.

Lock: The door is barred with a rotting timber beam on the opposite side of the door which holds it shut. A successful Strength (Athletics) check with DC21 (as per Toughness) will split the timber and open the door by 1d12 inches. Once the timber bar is gone/split then the DC drops to 15 to shove the door open a further 1d12 inches a time. A small creature (halfling/ gnome etc.) can squeeze through the gap in the door when it is opened by at least 18 inches. The door will need to be at least 24 inches wide to allow a medium sized creature to squeeze through.

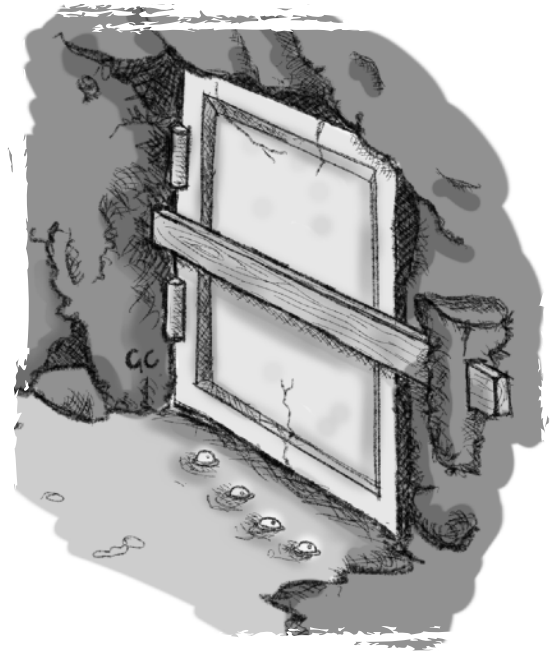

Trap: Hidden in the floor at the foot of the closed door are 4 upside down vials of poisonous gas - Spot DC 15. A successful Intelligence (Investigation) check with DC12 will reveal that removing the vials from the ground will prevent them from being crushed as the door swings open. The door will collide with the vials and trigger a gas cloud (damage below, a Constitution save will halve damage) if the door opens more than 20 inches wide.



If a creature doesn't spot the vials, they may well tread on one and set it off. Half damage due to diluted effect. The rest of the vials will then be spotted with a DC10 (easy).

DAMAGE

Level Damage Severity - Deadly

1-4 4d10 poison damage, Save DC16

5-10 10d10 poison damage, Save DC17

11-16 18d10 poison damage, Save DC18

17-20 24d10 poison damage, Save DC20

THE BEHOLDOOR

Threat is in the eye of the beholder.”
- Mohamed ElBaradei

Legend has it that not only do walls have ears, but doors have eyes in the lair of a vicious Beholder near to the Kryptgarden Forest.

The mere mention of the Beholddoor in the presence of a magic user is enough to cause panic and paranoia for most of them.

Material: An unknown metal alloy.

Toughness (AC): 20

Hit Points: 20

Size: Regular.

Description: Approaching the door they will see 4 key holes, 1 in each corner of the door. There is a central eye above the door which follows the closest creature to it. A successful Wisdom (Perception) check with DC10 will reveal that either side of the door jam, there are 10 shiny ‘eye’ jewels pointing towards one another. If 15 or more is rolled, then a 5th key hole will be spotted inside the mouth of central Beholder on the door.

Lock: The door is unlocked and can be opened at anytime. All attempts to pick the upper most key holes are at disadvantage, unless they are ‘large’ in size or lifted up to eye level with the key holes. To pick a lock a successful Dexterity check with DC16 is required. A failed attempt will trigger the eye above the door. Roll 1d10 and consult

Appendix H: Monsters.

Traps: There are several traps. The key hole locks and central key hole are trapped, and can ONLY be disarmed with a successful ‘Dispel Magic’ cast on EACH lock with a DC18. An Intelligence (Arcana) check with DC12, will reveal that the door locks are magically

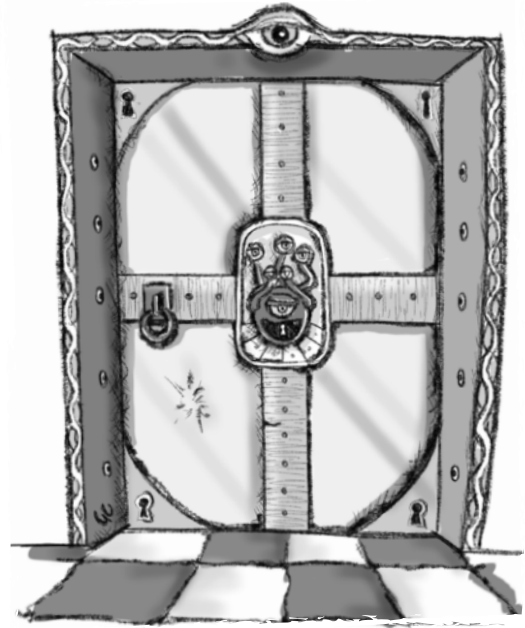

trapped. An Intelligence roll with a DC16 or higher will reveal that the 10 ‘door jam’ eyes plus the solitary eye above the door are where the magical traps are most likely attack from. Successfully picking one of the 5 locks will disarm one pair of the ‘door jam’ eyes. Roll randomly for which one.

Walking through the doorway without disarming the ‘jam eyes’ will result in being hit with a disintegration ray with damage and Dexterity save DC as per the table below.

However, if 2 pairs of eyes are disarmed, then a successful Dexterity (Acrobatics) with DC10 will enable safe passage past the door. Passing non-magical objects (see Appendix H: Monsters) into the eye beams will disintegrate certain objects too.

There is a faint ‘anti-magic’ zone around the door which makes dispelling the traps difficult.

DAMAGE

Level	Damage Severity - Deadly
1-4	4d10 force damage, Save DC16
5-10	10d10 force damage, Save DC17
11-16	18d10 force damage, Save DC18
17-20	24d10 force damage, Save DC20

Door to the Star People

Power is no blessing in itself, except when it is used to protect the innocent”
- Jonathan Swift

Deep in the sweltering, humid forest of Amtar, under eternal guard from the dreaded Gnollwatch Mountains - it is said that tall trees named Bluewood's grow. The wood, if magically treated can become as hard as steel but half as heavy.

Legend has it the a secretive tribe of wild elves named 'Star People' created a door from bluewood to protect the innocence of their female young before they came of age.

Material: Bluewood, magically treated.

Toughness (AC): 25 (strong)

Hit Points: 25

Size: Regular.

Description: The Star People door is intricately caved from a wood which has a very faded blue stained finish. There is no door handle nor lock to pick. The stone tongue threshold seamlessly joins with the carved wooden tongue at the bottom of the door.

Lock: With a successful Intelligence (Arcane) check of DC15, the door will be found to be locked using an enchantment which can only be broken by uttering the correct password. This password can be anything you have given or hidden away for the PC's to discover and use. Once the password has been spoken into one of the ears of the door, it will open to allow anyone to pass harmlessly beyond it. The door will close by itself (Strength 20) after 10 minutes. Or it can be closed manually - upon which it's magical lock immediately resets.

Trap: With an additional successful Intelligence (Arcane) check of DC15, the door will be found to be magically trapped. A



successful Intelligence (History) check of DC20 will reveal that these doors were used by a particular southern tribe of wild elves to protect the innocence of their female children.

If **Identify** is cast upon the door, then the magic caster will detect that a password is required, and the door is trapped against the **Dispel** and **Knock** spells. The magic emanating from the door is considered **Enchantment**. If a PC fails when casting one of those spells (with a spell DC as below) or causes damage (1 HP or more) to the door, it will immediately attack that PC once per round using it's enchantment with the following spell save DC's against **Wisdom (Saves are at DISADVANTAGE)**.

If the PC is a male, then for the next 24 hours, they will think that they are a female of their species and be charmed (see below). If the PC is already female, then they will be charmed and wish to protect the door as per the spell **Charm Person (PHB p.221)**.

ENCHANTMENT

Level	Intelligence Save
1-4	Wisdom Save DC16
5-10	Wisdom Save DC17
11-16	Wisdom Save DC18
17-20	Wisdom Save DC20

NEED MORE LEGENDARY DEADLY DUNGEON DOORS?

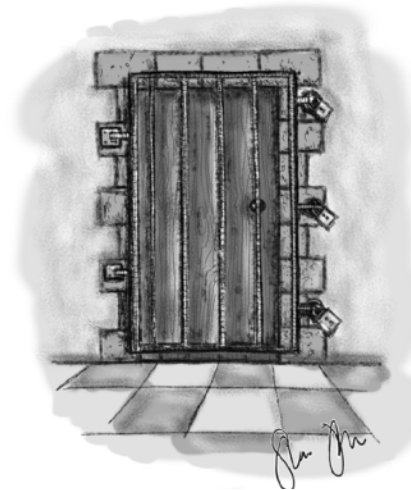
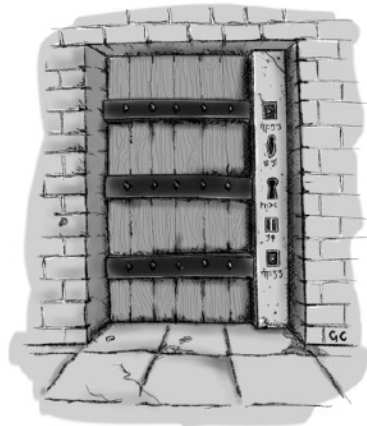
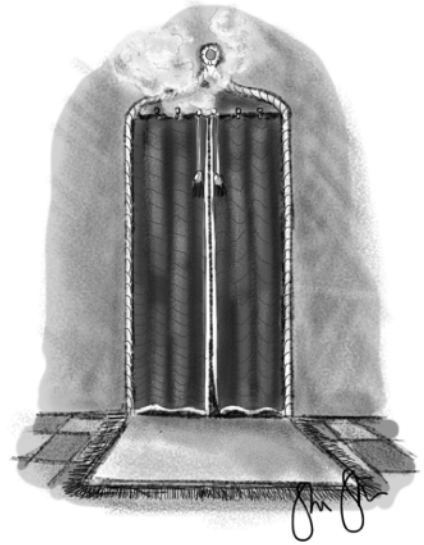

Become my patron on



APPENDIX F - WORKED EXAMPLE

GET YOUR d20's READY...

Here is an example of a random dungeon door for you to follow though to the end.

A. Door Materials

Door Material Table A1 : Rolled a 19, Exotic
Exotic Material Table A2 : Rolled a 5, Gold (min Toughness 15, min jammed DC20, DC10 STRENGTH check to open).
Door Toughness Table A3 : Rolled a 11, Regular (Toughness 15).
Door Size Table A4 : Rolled a 15, Regular.

B. Door Types

Door Properties Table B5 : Rolled a 15, Barred and Trapped (+3 Toughness unless removed, roll on table F1)

F. Trapped Doors

Trap Type Table F1 : Rolled a 16, magical trap, **Rune of Fear**.
Spot DC Table F2 : Rolled a 6, Very Easy (DC5).
Disarm DC Table F3 : Rolled a 18, Very Hard (DC25).
Damage Severity Table F4.2 : Rolled a 10, Dangerous (4d10).
Save DC & Att Bonus Table F5.2 : Rolled a 19 (DC15, Att +8).

G. Door Oddity

No. Properties Table G1 : Rolled a 16 (1 oddity).
Oddity Type Table G2 : Rolled 13, Faint glow and magical aura.

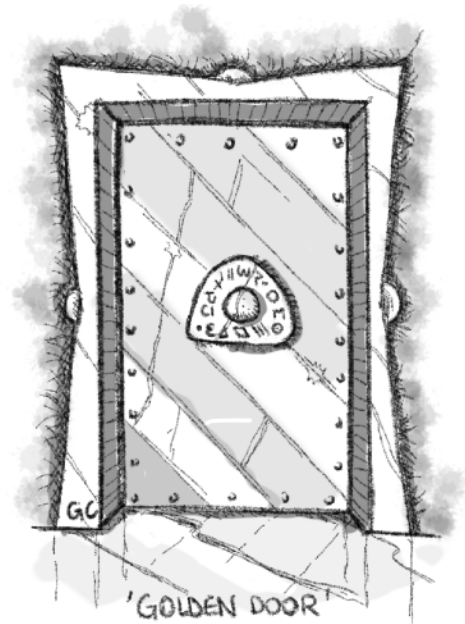

Door Name / Location: Treasure Door

Material: Gold

Initial Toughness (AC): 18 (15+3)

Hit Points

18

Size: Regular

Trap Type I: Fear Rune

Spot DC: 5
Disarm DC: 25
Damage Class: Dangerous
Escape/Save DC: 15

Oddity/Special Features:

1. Faint Glow and Magical Aura

APPENDIX G - THE TRAP CHECK LIST

Momma always told me to leap before you look, it keeps fear out of the action.”
- Frank, a half-orc Eldritch Knight

ARE YOU THE ROGUE?

If you are the party's rogue then we have a little check list which includes equipment and the steps required to defeat a door trap.

If you're the rogue, then print this off - because it just may save yours and your comrades lives.

S.L.I.D.E.

Here, you will find a list of steps to consider very carefully when approaching an unknown dungeon door - **S.L.I.D.E.**

1. **STOP** - Never rush in. Approach the door from either side if you can, and take it slowly. If you suspect a trap may have been laid before the door, then open your eyes and search the floor and ceiling as you move forward step by step.

2. **LOOK** - Not just look, but listen and sniff the air too (Wisdom/Perception check). A careful inspection of the surroundings and the surfaces of the door may well reveal clues as to what lies in store for you. IF you do suspect a trap then move onto the next step.

3. **INVESTIGATE** - If clues have presented themselves, then you must next understand how they are connected to the trap's trigger (Intelligence/Investigation). Once you understand how the trigger is set-off it will then require disarming.

4. **DISARM** - Take out your knife, or your pitons or perhaps your lock picks and try to prevent the trap from setting-off (Dexterity). This is probably the most dangerous part, and a failure to disarm may well trigger the traps effects in your face.

5. **ESCAPE** - BANG! The trap goes off! In order to survive you will need to be ready for when it does. Nimbly dodging at the last moment (Dexterity/Acrobatcs) is effective, but not as effective as not being there in the first place ;) Always consider the usefulness of the spells like Mage Hand or Knock, but attacking a lock from a distance and then simply pushing the door open using a long pole can work too...

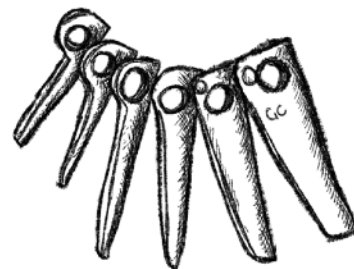

'PITONS'

EQUIPMENT LIST

- Acid (vial) 25gp
- Block & Tackle 1gp
- Crowbar 2gp
- Hammer 1gp
- Pitons 5cp each
- Magnifying Glass 100gp
- Portable Ram 4gp
- Rope (silk) 10gp
- Thieves Tools (PHB p.154) 25gp
- Ink Pan, Ink & Paper (20 shts) 12gp
- Pole (10ft) 5cp
- Soap 2cp
- Chalk 1cp
- Flask of Water 2cp

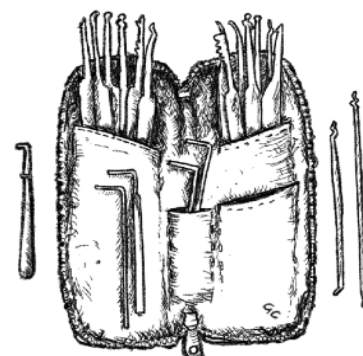

'LOCK PICKS'

APPENDIX H - MONSTERS

Giant Poisonous Snake

Medium beast, unaligned (MM p.327)

Armor Class: 14
Hit Points: 11(2d8+ 2)
Speed: 30 ft., swim 30 ft. ft.

STR	DEX	CON	INT	WIS	CHA
10 (0)	18 (+4)	13 (+1)	2 (-4)	10 (0)	3 (-4)

Skills: Perception +2
Senses: blindsight 10 ft., passive Perception 12
Challenge: 1/4(50 XP)

Actions

Bite.Melee Weapon Attack: bonus to hit as per **damage severity table**, reach 10 ft., one target. Hit: 6 (1d4 + 4) piercing damage, and the target must make a DC 11 Constitution saving throw, taking (see damage severity table) poison damage on a failed save, or half as much damage on a successful one.



MERRSHAULK'S
PORTCULLIS

Giant Constrictor Snake

Medium beast, unaligned (MM p.324)

Armor Class: 12
Hit Points: 60 (8d12+ 8)
Speed: 30 ft., swim 30 ft. ft.

STR	DEX	CON	INT	WIS	CHA
19 (+4)	14 (+2)	12 (+1)	1 (-5)	10 (0)	3 (-4)

Skills: Perception +2
Senses: blindsight 10 ft., passive Perception 12
Challenge: 2(450 XP)

Actions

Bite.Melee Weapon Attack: bonus to hit as per **damage severity table**, reach 10 ft., one creature. Hit: 11 (2d6 + 4) piercing damage.

Constrict.Melee Weapon Attack: bonus to hit as per **damage severity table**, reach 5 ft., one creature. Hit: 13 (2d8 + 4) bludgeoning damage, and the target is grappled (escape DC as per **damage severity table**). Until this grapple ends, the creature is restrained, and the snake can't constrict another target.



MERRSHAULK'S
PORTCULLIS

Mimic

Medium monstrosity (shapechanger), neutral (MM p.220)

Armor Class: 12 (natural armor)

Hit Points: 58 (9d8+ 18)

Speed: 15 ft.

STR	DEX	CON	INT	WIS	CHA
17 (+3)	12 (+1)	15 (+2)	5 (-3)	13 (+1)	8 (-1)

Skills: Stealth +5

Damage Immunities: acid

Condition Immunities: prone

Senses: darkvision 60 ft., passive Perception 11

Challenge: 2(450 XP)

Actions

Pseudopod. Melee Weapon Attack: +5 to hit, reach 5 ft., one target. Hit: 7 (1d8 + 3) bludgeoning damage. If the mimic is in object form, the target is subjected to its Adhesive trait.

Bite. Melee Weapon Attack: +5 to hit, reach 5 ft., one target. Hit: 7 (1d8 + 3) piercing damage plus 4 (1d8) acid damage.



MIMIC DOOR

Spawn of Kyuss

Medium undead, chaotic evil (VGtM p.192)

Armor Class: 10

Hit Points: 76 (9d8+ 36)

Speed: 30 ft.

STR	DEX	CON	INT	WIS	CHA
16 (+3)	11 (+0)	18 (+4)	5 (-3)	7 (-2)	3 (-4)

Saving Throws: Wis +1

Damage Immunities: poison

Condition Immunities: exhaustion, poisoned

Senses: darkvision 60 ft., passive Perception 8

Languages: understands the languages it knew in life but cannot speak

Challenge: 5 (1,800 XP)

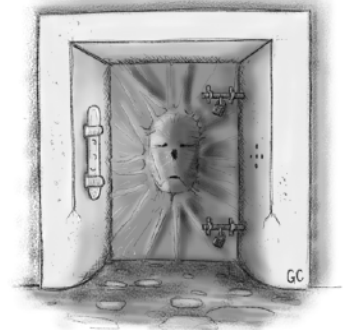

SKIN OF SIN

Regeneration: Regains 10 hit points at the start of its turn if it has at least 1 hit point and isn't in sunlight or running water. If it takes acid, radiant, or fire damage, then this trait doesn't function at the beginning of its next turn. Only destroyed if begins its turn with 0 hit points.

Worms: If spawn of kiss is targeted by an area effect that cures disease or removes curse, all the worms die and it loses its 'Burrowing Worms' action.

Actions

Multiattack. May make 2 attacks, with its claws and uses Burrowing Worms action.

Burrowing Worms. A worm launches itself from the spawn of Kyuss (or from another surface) at one humanoid that the spawn can see within 10ft of it. The worm latches itself onto a targets skin

unless the target succeeds on a DC11 Dexterity saving throw. The worm is Tiny undead with AC6, 1 hit point, a 2 (-4) in every ability score and a speed of 1ft. While on the targets skin, the worm can be killed by normal means or scraped off using an action. Otherwise the worm burrows under the skin of the target at the end of the target next turn, dealing 1 piercing damage to it. At the end of each of it's turns thereafter, the target takes 7 (2d6) necrotic damage per worm infesting it (maximum 10d6). A worm infested target dies if it drops to 0 hit points, then rises 10 minutes later as a spawn of Kyuss. If a worm infested creature is targeted with a remove curse or cure disease, all worms infesting it wither away and die.

Claw. Melee Weapon Attack: +6 to hit, reach 5ft, one target. Hit: 6 (1d6+3) slashing damage plus 7 (2d6) necrotic damage.

Wandering Monsters. There is a 10% (1d100) chance of meeting a Spawn of Kyuss in the same room or corridor to where the SKIN of SIN door can be found.

The Beholdoor

If a lock pick skill check fails, then the eye above the door uses a ray attack a single random creature within in line of sight and 120ft, Roll 1d10 to determine the effects of each ray attack.

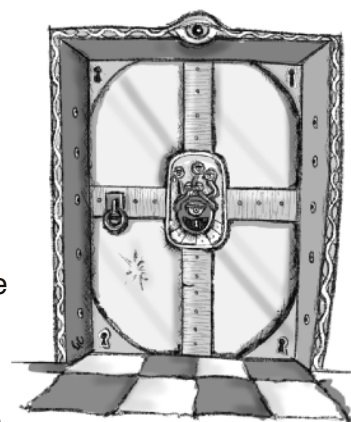

1. Charm Ray. The targeted creature must succeed on a DC16 Wisdom saving throw or be charmed by the **Beholdoor** for 1 hour, or until the creature is harmed (roll save once again). Whilst charmed the creature will protect the door from being opened with it's life.

2. Paralyzing Ray. The targeted creature must succeed on a DC 16 Constitution saving throw or be paralyzed for 1 minute. The target can repeat the saving throw at the end of each of its turns, ending the effect on itself on a success.

3. Fear Ray. The targeted creature must succeed on a DC 16 Wisdom saving throw or be frightened for 1 minute. The target can repeat the saving throw at the end of each of its turns, ending the effect on itself on a success. A frightened creature will immediately move away from the door and will not move back towards it until it has successfully made the save.

4. Slowing Ray. The targeted creature must succeed on a DC 16 Dexterity saving throw. On a failed save, the target's speed is halved for 1 minute. In addition, the creature can't take reactions, and it can take either an action or a bonus

5. Enervation Ray. If the target is a creature, it must succeed on a Dexterity saving throw (see below) or take necrotic damage (see below), or half as much damage on a successful one.

DAMAGE

Level	Damage Severity - Setback
1-4	1d10 necrotic damage, Save DC10
5-10	2d10 necrotic damage, Save DC10
11-16	4d10 necrotic damage, Save DC11
17-20	10d10 necrotic damage, Save DC11

6. Telekinetic Ray. The target must succeed on a DC 16 Strength saving throw or moved 1d20 feet AWAY in a random direction. It is restrained by the ray's telekinetic grip until the beholder's uses it's eye once again, or until it is opened.

7. Sleep Ray. The targeted creature must succeed on a DC 16 Wisdom saving throw or fall asleep and remain unconscious for 1 minute . The target awakens if it takes damage or another creature takes an action to wake it. This ray has no effect on constructs and undead.

8. Petrification Ray. The targeted creature must make a DC 16 Dexterity saving throw. On a failed save, the creature begins to turn to stone and is restrained. It must repeat the saving throw at the end of its next turn . On a success, the effect ends. On a failure , the creature is petrified until freed by the *greater restoration* spell or other magic.

9. Disintegration Ray. If the target is a creature, it must succeed on a Dexterity saving throw (see below) or take force damage (see below). If this damage reduces the creature to 0 hit points, its body becomes a pile of grey dust. If the target is a Large or smaller non magical object or creation of magical force, it is disintegrated without a saving throw. If the target is a Huge or larger object or creation of magical force, this ray disintegrates a 10-foot cube of it.

DAMAGE

Level	Damage Severity - Dangrous
1-4	2d10 force damage, Save DC12
5-10	4d10 force damage, Save DC13
11-16	10d10 force damage, Save DC14
17-20	18d10 force damage, Save DC15

10. Death Ray. If the target is a creature, it must succeed on a Dexterity saving throw (see below) or take necrotic damage (see below). The target dies if the ray reduces it to 0 hit points.

DAMAGE

Level	Damage Severity - Deadly
1-4	4d10 necrotic damage, Save DC16
5-10	10d10 necrotic damage, Save DC17
11-16	18d10 necrotic damage, Save DC18
17-20	24d10 necrotic damage, Save DC20

APPENDIX K - ADDENDUMS & REVISIONS

H1. ADDENDUMS & REVISIONS

Ref.	Chapter Title	Description	By	Date
V.1.02	2. Rolling Random Doors	Additions to Hidden Doors, Table D2.	GC	27.01.17
V.1.02	2. Dungeon Door Oddities	Additions to Table G2.	GC	27.01.17
V.1.02	Appendix E - Legendary DD's	New Doors	GC	28.01.17
V.1.02	Appendix H - Monsters	New Appendix	GC	02.02.17
V.1.02	Appendix K - Addendums	New Appendix	GC	02.02.17
V.1.02	Contents	Swapped around Chapter 2 with Chapter 3!	GC	03.02.17
V.1.03	Contents	2 Competition Winners added to Thank Yous.	GC	18.02.17
V.1.03	Appendix E - Legendary DD's	2 Competition Winner doors plus another one	GC	18.02.17
V.1.03	Appendix H - Monsters	New 'Beholder' door stats added.	GC	18.02.17

