

CLASSIC

# BATTLETECH



# TACTICAL OPERATIONS



# FORCES ON WORLD!



Take your warfare to a whole new level of excitement! Deploy under cover of exotic weather and severe planetary conditions. Surprise your enemy with your mastery of new battlefield tactics—from artillery to command-level comms to minefields—as well as cutting-edge, prototype technologies! A daring commander can take advantage of any or all of these....if he's brave enough to seize the moment!

*Tactical Operations* is the one-source reference for advanced rules that apply to on-world operations. It includes new movement and combat options, an extensive Advanced Weapons and Equipment section, and the rules for playing and constructing advanced Support Vehicles and Mobile Structures.



FOR USE WITH

CLASSIC  
**BATTLETECH**  
TOTAL WARFARE

**CATALYST**  
game labs™

Under License From

**WK**  
GAMES

©2008 WizKids, Inc. All Rights Reserved. Classic BattleTech Tactical Operations, Classic BattleTech, BattleTech, BattleMech, 'Mech, and WK Games are registered trademarks and/or trademarks of WizKids, Inc. in the United States and/or other countries. Catalyst Game Labs and the Catalyst Game Labs logo are trademarks of InMediaRes Productions, LLC.

WEBSITE: CATALYSTGAMELABS.COM



# **CLASSIC BATTLETECH™**

## **TACTICAL OPERATIONS**

• **CATALYST GAME LABS** •



The Fifth Free Worlds Guards battle the Second Donegal Guards in the blasted ruins of a factory complex.

## INTRODUCTION

8

### Advanced Rules

Tactical Operations	8
Strategic Operations	8
Interstellar Operations	8

### Choose What You Like

Player Adjudication	9
---------------------	---

### Fiction

Fiction Vs. Rules	9
Fiction Vs. Art	10

### Components

Support Vehicles	10
Mobile Structures	10

### Record Sheets

Large Naval Vehicle Record Sheet	10
Satellite Record Sheet	11
Structure Record Sheet	11
Advanced Rules Record Sheets	11
Additional Record Sheets and Templates	13

### TACTICAL ANALYSIS

14

## ADVANCED GROUND MOVEMENT

18

Movement Modes	18
Standing Still (Expanded: Movement Mode)	18
Sprinting (Movement Mode)	18
Evading (Movement Mode)	18
Shielding (Movement Mode)	19
Physical Defense (Movement Mode)	20
Crawling (Movement Mode)	20
Hurried Movement	20
Hull Down	21
Backward Movement (Expanded)	22
Climbing and Leaping	22
Stacking (Expanded)	22

### Skidding

23

### Piloting Skill Rolls

23

Fumbles	23
Taking Damage	23
Leg Damage	24
Falling (Expanded)	24
Attempting to Stand	24

### Vehicles

24

Movement	24
----------	----

### Infantry

27

Squad Deployment	27
Movement on Pavement	27
Fast Movement	27
Climbing	27

### Movement Dice (Tips and Suggestions)

27

### Planetary Conditions

28

Expanded Movement Cost and Planetary Conditions Rules	28
Base Terrain Types	30
Buildings	30
Gravel Piles	30
Half Levels	31
Heavy Industrial Zone	31
Jungle	31
Level 1 Foliage	36
Magma	36
Planted Fields	38
Rough (Ultra)	39
Rubble (Ultra)	39
Sand	39
Sheer Cliffs	39
Tundra	40
Woods (Ultra-Heavy)	40
Terrain Modifications	40
Black Ice	40
Bug Storms	40
Deep Snow	41
Extreme Depths	42
Fire	43
Smoke	47
Geysir	48



Hazardous Liquid Pools	49
Ice	50
Mud	50
Rapids	50
Rails	51
Roads	51
Swamp	51
Thin Snow	52
Torrent	52
Water Flow	52
Terrain Conditions	54
Atmospheric Pressure (Density)	54
Earthquake	55
Electromagnetic Interference (EMI)	55
High/Low Gravity	55
Meteor Showers	56
Tainted and Toxic Atmospheres	56
Weather Conditions	57
Fog	57
Hail	57
Light	58
Rain	59
Snow	60
Wind	61
Misc.	62
Blowing Sand	62
Extreme Temperature	62
Bog Down Rules	62
Careful Movement	62
Heat Scale Modifiers	62
Terrain Factor Rules	62
Planetary Conditions Tables	68

**GLANCING BLOW** 70

**ADVANCED COMBAT** 74

<b>General Rules</b>	74
Expanded Critical Hits and Damage	74
Fumbles	75
Floating Critical Rule	77
Advanced Hit Locations	77
Engine Explosions	77
Called Shots	78
<b>Weapons Attacks</b>	78
Line of Sight and Dead Zones	79
Glancing/Direct Blows	80
Missed Shots	81
Damage	83
Advanced Firing	84
Partial Cover	87
<b>Physical Combat</b>	88
Weight Class Physical Attack Modifiers	88
New Physical Attack Weapons	88
New Attack Types	88
Charging	91
Death From Above	91
Intentional Falls From Above	91
<b>Picking Up and Throwing Objects</b>	92
Picking Up Inanimate Objects	92
Throwing 'Mechs and ProtoMechs	95
Picking Up and Throwing Vehicles	96
Picking Up and Throwing Battle Armor	97
Dropping or Setting Down Inanimate Objects	98
Dragging a 'Mech	99
<b>Other Combat Weapons and Equipment</b>	99
Active Probes	99
Anti-Missile Systems	99
Autocannons	100
ECM Suites	100
Energy Weapons	102
Gauss Weapons	102
Machine Guns	102

Missiles	102
Particle Projector Cannon (PPC)	103
Retractable Blade	104
<b>Heat</b>	104
Avoiding Shutdown	104
Rerouting Heat Sink Coolant ('Mechs only)	105
Heat Sink Coolant Failure	105
<b>Vehicles</b>	107
Firing Arcs	107
Vehicle Effectiveness	107
VTOL Special Attacks	107
<b>Infantry</b>	108
Digging In	108
Conventional Infantry Squad Deployment	108
Using Non-Infantry Units As Cover	108
Battle Armor Infantry	108
<b>Weapon Resolution Dice (Tips and Suggestions)</b>	109
<b>BOOM</b>	110

**ADVANCED BUILDINGS** 114

Structure Record Sheet	114
<b>Advanced Building Classifications</b>	114
Building Classifications	116
<b>Standard Rules Expansions</b>	118
Moving Through Advanced Buildings	118
Advanced Building Critical Damage	120
Armored Buildings	121
Attacking Buildings From Within	121
Construction Factor (Expanded)	121
Building Collapse (Expanded)	123
Scaled Damage	126
<b>Building Construction</b>	128
Building Basics	128
The Design Process	128
Step 1: Establish Superstructure	128
Step 2: Add Armor	130
Step 3: Install Components	131
Step 4: Complete the Record Sheet	133
<b>Advanced Building Equipment</b>	133
Automated Weapons	133
Power Generators	133
Liquid Fuel/Chemical Storage Tanks	134
Environmental Sealing	136
Heavy Metal Superstructure	137
High/Low Ceilings	137
Industrial Elevators	137
Large Doors	138
Open Space Construction	138
Subsurface/Underwater Structures	140
Tunnels	141
<b>Castles Brian Complexes</b>	141
<b>BLOODY DIVIDENDS</b>	144

**ADVANCED SUPPORT VEHICLES** 148

<b>Satellites</b>	148
Movement (Outside of Game Play)	148
Movement (During Game Play)	148
Rail	149
Movement	149
Carrying Units	150
Combat	153
Charging Rail Vehicles	154
Accidental Falls From Above	154
<b>Large Naval Vessel Support Vehicles</b>	154
Movement	154
Stacking	156
Carrying Units	156
Flight Decks	156

INTRODUCTION

ADVANCED  
GROUND MOVEMENT

ADVANCED  
COMBAT

ADVANCED  
BUILDINGS

ADVANCED  
SUPPORT  
VEHICLES

GENERAL  
RULES

ADVANCED  
SUPPORT VEHICLE  
CONSTRUCTION

ADVANCED  
WEAPONS  
AND EQUIPMENT

INDEX

RECORD SHEETS



Naval Tractors	156
Combat	157
Critical Damage	159
Electronic Equipment	159
Unit Destruction	159
<b>Large Airship Support Vehicles</b>	164
Movement	164
Stacking	164
Carrying Units	164
Flight Decks	164
Combat	164
Electronic Equipment	164
Accidental Falls From Above	164
<b>Mobile Structures</b>	165
Movement	165
Facing	167
Collisions	167
Buildings	167
Stacking (Ground Mobile Structures)	168
Carrying Units	170
Flight Decks	170
Combat	171
Critical Hits	172
Destroying a Mobile Structure	172
Unit Displacement	173
<b>INTO THE FIRE</b>	174

## GENERAL RULES 178

<b>Advanced Scatter</b>	178
Advanced Altitude Bombing Scatter	178
<b>Artillery</b>	179
Sequence of Play	179
Artillery Not Directly on the Playing Area	179
Targeting	180
Damage	182
Direct-Fire Artillery	185
Counter-Battery Fire	186
Planetary Conditions	186
<b>Battle Armor Weights</b>	186
<b>Battlefield Wreckage</b>	187
<b>Boarding Actions (Non-Infantry)</b>	188
Mounting Through A Bay Door (Into a Cargo Bay)	188
Weapon Attacks in Cargo Bays	188
Fire Due to Weapon Attacks in Cargo Bays	190
<b>Command-Level (Tactical) Comms</b>	191
Commanders	191
Satellites	193
<b>Ejection and Abandoning Units</b>	196
'Mechs	196
Vehicles	197
Naval Vessels	197
<b>Fatigue</b>	198
<b>Improved Positions</b>	198
<b>Infantry Vs. Infantry Actions</b>	199
Boarding Actions (Infantry)	199
Infantry Vs. Infantry Action Inside A Building	201
Resolving Infantry Vs. Infantry Actions	201
Re-Converting Marine Points Score	205
Crew Losses and Crew Hits	206
Using A Captured Unit/Building	207
<b>Minefields</b>	207
Conventional Minefields	208
Command-Detonated Minefields	209
Vibrabomb Minefields	209
Active Minefields	209
Combined Minefields	210
Weapon-Delivered Minefields	210
Clearing Minefields	210

<b>Morale</b>	211
Morale Checks	211
Broken Morale	212
Recovering Nerve	213
<b>Rearming Under Fire</b>	213
<b>Rolling Maps</b>	214
<b>Simultaneous Movement</b>	215
Plotting Movement	215
Movement	215
<b>Taking Control of A Unit</b>	216
Abandoned Units	216
Swarming	217
<b>Transport Bays (Expanded)</b>	217
<b>Vehicle Crews</b>	218
Crew Numbers And Abilities	218
<b>Zip Lines</b>	219
<b>Concealing Information</b>	219
Record Sheets And Set-Up	219
Available Information	219
Scanning	219
<b>Double-Blind Rules</b>	220
Sequence of Play	220
Initiative Phase	221
Movement Phase (Spotting Phase)	221
Weapon Attack Phase	225
<b>UNsung TECHNOLOGIES</b>	226

## ADVANCED SUPPORT VEHICLE CONSTRUCTION 236

<b>The Basics of Advanced Unit Design</b>	236
Unit Type	236
Technology Base	237
Weight	237
<b>Designing Advanced Support Vehicle Units</b>	238
<b>Step 1: Design the Chassis</b>	238
Choose Advanced Support Vehicle Type	238
Choose Technology Base	239
Choose Weight	240
Allocate Weight for Internal Structure/Structural Integrity	242
<b>Step 2: Install Engines And Control Systems</b>	245
Install Engine	245
Determine Fuel Capacity	248
Determine Structural Integrity (Airships Only)	249
Add Lift/Dive Equipment	249
Determine Jump Capability	249
Add Control/Crew Systems	249
Special Enhancements	251
<b>Step 3: Add Heat Sinks</b>	251
<b>Step 4: Add Armor</b>	252
<b>Step 5: Add Weapons, Ammunition And Other Equipment</b>	254
<b>Step 6: Complete The Record Sheet</b>	258
Support OmniVehicles	258
<b>Designing Mobile Structures</b>	259
<b>Step 1: Establish Function</b>	259
Choose Mobile Structure Type	259
Choose Technology Base	260
Choose Class, Size, And Shape	261
Construction Factor and Internal Weight Capacity	261
<b>Step 2: Install Power, Motive, And Control Systems</b>	262
Install Power System	262
Install Motive System	263
Determine Fuel Capacity	263
Add Crew	264
Special Enhancements (Enviro Sealing, Modular Structure Linkage)	265
<b>Step 3: Install Armor</b>	266
<b>Step 4: Install Weapons, Heat Sinks, And Equipment</b>	266
<b>Step 5: Complete The Record Sheet</b>	269
<b>THE EFFICIENCY OF ROME</b>	270



# ADVANCED WEAPONS AND EQUIPMENT

274

<b>Equipment Notes</b>	275	Field Guns/Field Artillery	311	Power Collector and Microwave Transmitter	336
Active Probe	278	Flamers	312	PPC Capacitor	337
Actuator Enhancement System (AES)	279	Flight Deck/Helipad	312	ProtoMech Melee Weapon	337
Angel ECM Suite	279	Fluid Gun	313	Recon Camera	337
Armor	279	Gauss Rifles	313	Rifle (Cannon)	338
Armored Components	283	Grav Deck	315	Satellite Imagers	338
Armored Motive Systems	283	Grenade Launchers, Vehicular (VGL)	315	Specialized Infantry	340
Artemis V Fire-Control System	283	Handheld Weapons	315	Structure	342
Artillery	284	Heat Sinks	316	Sub-capital Weapons	343
Artillery Cannons	285	Infantry Armor	317	Sub-Compact K-F Drive System	343
Autocannon	285	Landing Deck	319	Supercharger	345
Battle Armor Mechanical Jump Booster	286	Lasers	319	Taser	345
Battle Armor Myomer Booster	287	Laser Anti-Missile System	322	Thunderbolt Missile Launcher	347
Battle Armor Detachable Weapon Pack	287	Laser Insulator	322	Turrets	347
BattleMech HarJel System	288	Light Sail	323	Vehicular/Battle Armor Dropchute	348
BattleMech Melee Weapons	288	Lithium-Fusion Battery	323	Vehicular Jump Jets	348
BattleMech/ProtoMech Motive Systems	292	Mass Driver	323	Void-Signature System	349
Beast-Mounted Infantry	295	'Mech Mortars	324	VTOL Jet Booster	350
Blue Shield Particle Field Damper (PFD)	296	Mechanized VTOL Infantry	324	VTOL Mast Mount	350
Booby Trap	297	MechWarrior Aquatic Survival System	325	Xenoplanetary Condition-Trained Troops	351
C <sup>3</sup> Systems	297	Mine Dispensers	325	<b>Alternative Munitions</b>	352
CASE II	299	Minesweeper	326	Autocannon Munitions	352
Chaff Pod	299	Missile Launchers	326	Artillery Munitions	353
Chameleon Light Polarization Shield (LPS)	300	Mobile Field Base	330	Bomb Munitions	357
Cockpit Systems	300	Mobile Hyperpulse Generators	330	Flamer/Fluid Gun/Sprayer Ammunition	360
Collapsible Command Module (CCM)	301	M-Pod	330	Grenade Launcher Munitions	363
Combat Vehicle Chassis Modifications	302	MRM "Apollo" Fire Control System	330	Mines	364
Coolant Pod	303	Naval Autocannons (Capital AC)	331	Missile Munitions	367
Disposable Weapons	304	Naval C <sup>3</sup>	332	'Mech Mortar Ammunition	373
Docking Hardpoint (Docking Collar)	304	Naval Comm-Scanner Suite	332	Remote Sensors	375
Docking Thrusters	305	Naval Gauss (Capital Gauss)	333	<b>Advanced Construction Options</b>	376
Drone (Remote) Systems	305	Naval Laser (Capital Laser)	333	Fractional Accounting	376
Energy Storage Batteries	306	Naval PPC (Capital PPC)	333	Mixed Technologies	377
Engine Systems	307	Naval Repair Facilities	334	Patchwork Armor	377
Ejection Systems	309	Naval Tug Adaptor	334	Super-Heavy Vehicles	378
Electronic Warfare (EW) Equipment	310	Null-Signature System	336	Ultra-Light BattleMechs	378

## ADVANCED BATTLE VALUES 378

Satellites	378
Rail Vehicles	378
Large-Sized Airships	379
Large-Sized Naval Vessels	379
Mobile Structures	379
Step 1: Calculating Defensive Battle Rating	379
Step 2: Calculating Offensive Battle Rating	379
Step 3: Calculate The Final BV	379
<b>Advanced Infantry</b>	379
Step 1: Calculating Defensive Battle Rating	379
Step 2: Calculating Offensive Battle Rating	379
Step 3: Calculate The Final BV	379
<b>Advanced Weapons and Equipment</b>	380
Actuator Enhancement System	380
Armor	380
Armored Components	380
Battle Armor Mechanical Jump Booster	380
Battle Armor Myomer Booster	380
Battle Armor Detachable Weapon pack	380
BattleMech Mechanical Jump Boosters	380
BattleMech/ProtoMech Partial Wing	380
BattleMech UMU System	380
Blue Shield PFD	380
CASE II	381
Chameleon Light Polarization Shield	381
Cockpit Systems—Torso-Mounted Cockpit	381
Combat Vehicle Chassis Modifications	381
Coolant Pod	381
Engine Systems	381

Handheld Weapons	381
Laser Anti-Missile System	381
Laser Insulator	381
Laser—Variable Speed Pulse	382
Null-Signature System	382
Patchwork Armor	382
PPC Capacitor	382
Shields	382
Structure	382
Supercharger	382
Turrets	382
Vehicular Jump Jets	382
Void-Signature System	382
VTOL Jet Booster	382
VTOL MAST Mount	382
<b>Constructing A Battle Force (Addendum)</b>	386
Alternative Munitions (New)	386
Target Acquisition Gear (Expanded)	386
Command, Control and Communications (Expanded)	386
External Stores (Expanded)	386
Skill Ratings (Expanded)	386
Force Size	386
Minefields (New)	386

## INDEX 387

## RECORD SHEETS 391

## TABLES 404

INTRODUCTION

ADVANCED GROUND MOVEMENT

ADVANCED COMBAT

ADVANCED BUILDINGS

ADVANCED SUPPORT VEHICLES

GENERAL RULES

ADVANCED SUPPORT VEHICLE CONSTRUCTION

ADVANCED WEAPONS AND EQUIPMENT

INDEX

RECORD SHEETS



# CREDITS

## Project Concept

Randall N. Bills

## Project Development

Herbert A. Beas II  
Randall N. Bills

## Writing

### Fiction

Randall N. Bills  
Jason M. Hardy  
Mike Miller  
Steven Mohan, Jr.  
Jason Schmetzer

### Rules

Herb A. Beas II  
Randall N. Bills

### Additional Rules

Ken' Horner  
Nick Marsala  
David McCulloch  
Mike Miller  
Jim Rapkins  
Ben Rome

## Product Editing

Diane Piron-Gelman

## BattleTech Line Developer

Herbert A. Beas II

## Production Staff

### Art Direction

Randall N. Bills

### Cover Art

Michael Komarck

### Cover Design

Adam Jury

### Classic BattleTech Logo Design

Shane Hartley and Steve Walker

### Graphic Presentation

Adam Jury  
David M. Stansel-Garner  
Troy Stansel-Garner

### Layout

Adam Jury (Rules)  
Matt Heerdt (Fiction)

### Illustrations

Doug Chaffee  
Chris Lewis  
Duane Loose  
Matt Plog  
Klaus Scherwinski  
Franz Vohwinkel

## Miniatures Painting & Photography

Ray "Adrian Gideon" Arrastia  
William "souguru" Burt  
Chris "Pendragon" Dolega  
Paul "DarkMarauder" Eckes  
Dave "Hauptmann" Fanjoy  
Joel "Psycho" Hardwick  
Ross "Savage Coyote" Hines  
David "DAK" Kerber  
Frederic "Foxbat" Lagoanere  
Steve "MadDoc" Livingston  
Mark "Hyena" Maestas  
Ryan "B1BFlyer" Peterson  
Lance "Jal Phoenix" Scarinci  
Ed "Captain of the Watch" Smith

## Terrain

Iron Wind Metals, Herpa Miniature Models,  
GHQ Miniatures, Ground Zero Games,  
William Burt and Steve Satak (2007 Diorama),  
Dwin Craig (for Dave Fanjoy)

## Map of the Inner Sphere

Øystein Tvedten

## Record Sheets

David L. McCulloch

## Index

Rita Tatum

## Additional Design and Development

*The following people have been involved in the creation and development of Classic BattleTech rules, either by writing material that was assimilated into the main body of the rules, serving as the BattleTech line developer in the past, or otherwise contributing to the game in a major way.*

Samuel B. Baker, Herb Beas, Randall N. Bills, Forest G. Brown, Chuck Crain, Chris Hartford, Clare Hess, Scott Jenkins, J. Andrew Keith, James R. Kellar, Dale Kemper, L.R. "Butch" Leeper, Bryan LiBrandi, Jim Long, David McCulloch, Jim Musser, Bryan Nystul, Mike Nystul, Blaine Pardoe, Boy F. Peterson Jr., Rick Raisley, Ben Rome, Jerry Stenson, Christoffer Trossen, Wm. John Wheeler.

## Acknowledgements

To Mike Miller for constantly answering my "So, how does the science of this game play rule work?" questions.

To Paul Sjardijn for coining the phrase "yeah, we've got a rule for that." Blame him.

To Joel Bancroft-Connors, Paul Sjardijn and Eberhard "Rote Baron" von Massenbach for going above and beyond in catching the little things and for allowing me to constantly ping them in IM to test a new rule.

To Herb Beas for tackling the hideously complex Equipment and Construction rules, as well taking on the Advanced Building section at the last minute.



To the core group of people who, to one extent or another, have significantly contributed to transferring *Classic BattleTech* to its new home, and to taking it to a new level: Ray Arrastia, Herb Beas, Loren Coleman, Warner Doles, David M. Stansel-Garner, Diane Piron-Gelman, Jason Hardy, Chris Hartford, Jason Knight, Chris Lewis, David McCulloch, Ben Rome, Matt Plog, Paul Sjardijn, Peter Smith, Scott Taylor, Christoffer Trossen, Øystein Tvedten, Jason Vargas, and the fanatic core of fact-checkers and playtesters who often worked under “urgent data requests” more often than we’d like to admit.

To Ray Arrastia, whose diagrams have made all of these rules books so much easier to understand...and raised the bar for how great an example can look.

To Diane Piron-Gelman for helping turn my text into solid prose and for editing two books in one.

To Adam Jury for putting up with the layout of these massive and incredibly complex layout jobs and doing it with a relatively low expletive count.

To all the Commandos for their ongoing stalwart support! Hope you all get a lot of use out of this book.

To the camospecs.com team that keeps raising the bar and going “there” to create new and jaw-droppingly-cool dioramas for these rulebooks.

To Bryn Bills and Kristian Frosig, who “forced me” to start running a campaign for them (giving me the chance to remember how much I love to still play the game) and who came up with several concepts that are now rules in the book. Your constant and Infectious love of the universe and game helped me through several of the darker times of this book.

#### Playtesters/Proofers/Fact Checkers

Joel Agee, Ray “Adrian Gideon” Arrastia, Joel Bancroft-Connors, Ron Barter, Paul “Blackhorse” Bowman, Brent Dill, Dan Eastwood, Dave Fanjoy, Bruce Ford, Anthony Hardenburgh, John “Worktroll” Haward, Glenn Hopkins, John “Bleusman” Hudson, David “DAK” Kerber, Rodney Klatt, Michael “Konan” Koning, Alan “Brainburner” Kreilick, Edward “Tenaka Furey” Lafferty, Edward Lott, Nick Marsala, Eberhard “Rote Baron” von Massenbach, Brian McAuliffe, Tim McAuliffe, Mike Miller, Jeff Morgan, Darrell “FlailingDeath” Myers, Andrew Norris, Jason Paulley, Michael Pfister, Aaron “Gravedigger” Pollyea, Jim Rapkins, Rick “Rick Steele” Remer, Eric “Mendruco” Salzman, Björn “Keiran” Schmidt, Christopher K. Searls, Chris Sheldon, Paul Sjardijn, Jeff Skidmore, Peter Smith (played by Peter Smith), Sam “Wasp” Snell, Joel Steverson, Geoff “97jedi” Swift, Roland “Ruger” Thigpen, Jason “Panzerfaust 150” Weiser, Chris “Chinless” Wheeler, Paul “Weasel” Wolf, Patrick Wynne; Steel City MechWarriors: Rich Cencarik, Rich Darr, Brian Golightly, Dave Lang, Drew Martin.

#### Additional Thanks

To the following on-line players that provided great suggestions, off of which many of the rules in this book were built: 3rdcrucislancers, abandon, adept dave Baughman, agen, aparbiter, asano, atlas3060, auren, awprime, axeman89, bean2213, bedwyr, Blackhorse 6, blacksheep, bluedragon7, bluetiger, boilerman, bored\_lyron, boyscout, bryanc, bulldog79, cache, cannonshop, captainjohn, casper, chaos cat, charlie tango, chrisxa, cobrausn, coelacanth, daemion, dark jackal, dark jaguar, dark\_falcon, darkstar2011, Davion, death-knight69, Deathrider6, demi-precentor worktroll,

diplominator, dukeroyal, elsn, failure16, fireangel, foxes teeth, freak, gaiiten, gbscientist, general308, geoff watson, ghost0402, glitterboy2098, gojira01, gomi, goose, gracus, greywolfactual, gus, Harvey, hunterada, ice\_trey, idea weenie, istal devalis, jackmc, jedibear, jeyar, jibbajabbawocky, jimdigris, jink rum, jmiles2, jungle boy, kit\_desummersville, kobra, kojak, kuttsinister7, Leon\_Shirow, lisette woo, lyonheart, mad malefactor, malakar, martius, mattlov, max francis vard, minchandre, mock26, mostro\_joe, mystic, nan, nightlord01, nikita, oldfart3025, omaharenegade, panzerfaust150, perkinc, peter smith, praetorian, prometheus fire, purpledragon, rage, redshirt, revanche, rexor-k, Rick Raisley, rommel\_twee, shadow slayer, shadow\_walker, shadow6, shatara, shijima, shockwave, sierra\_gulf, skiltao, sldf\_spector, snake\_eyes, sudedei, sushi, talz, teamnutmeg, tel hazen, torrent, truegrit, truetanker, twycross, urgru, vandal, vega\_obscura, vorpall, wantec, warchicken, wasp, weirdguy, weirdo, welshman, werewolf, whistler, wildfire, wolf lancer 4, wolfspider, wrangler, zone of alienation.

#### Special Thanks

To David Stansel-Garner and Loren Coleman for not yelling “too” loudly as I overwrote by a mere 200k and allowing me to insert another one of these giant tomes into the Catalyst Game Labs production schedule.

#### Dedication

To Tara Suzanne Bills for allowing me to continue playing in the sand box that I love even as I’m supposed to be “moving on.” If you love this book, give her a giant thanks the next time you see her.

©2008 WizKids, Inc. All Rights Reserved. Classic BattleTech Tactical Operations, Classic BattleTech, BattleTech, ‘Mech, BattleMech, MechWarrior and WK Games logo are registered trademarks and/or trademarks of WizKids, Inc in the United States and/or other countries. No part of this work may be reproduced, stored in a retrieval system, or transmitted in any form or by any means, without the prior permission in writing of the Copyright Owner, nor be otherwise circulated in any form other than that in which it is published. Catalyst Game Labs and the Catalyst Game Labs logo are trademarks of InMediaRes Productions, LLC.

Published by Catalyst Game Labs, an imprint of InMediaRes Productions, LLC  
PMB 202 • 303 91<sup>st</sup> Ave NE • G701 • Lake Stevens, WA 98258

#### FIND US ONLINE:

classicbattletech@catalystgamelabs.com  
(e-mail address for any Classic BattleTech questions)  
<http://www.classicbattletech.com>  
(official Classic BattleTech web pages)  
<http://www.CatalystGameLabs.com>  
(Catalyst web pages)  
<http://www.wizkidsgames.com/mechwarrior/>  
(official MechWarrior web pages)  
<http://www.wizkidsgames.com>  
(WizKids web pages)  
<http://www.battlecorps.com/catalog>  
(online ordering)

INTRODUCTION

ADVANCED  
GROUND MOVEMENT

ADVANCED  
COMBAT

ADVANCED  
BUILDINGS

ADVANCED  
SUPPORT  
VEHICLES

GENERAL  
RULES

ADVANCED  
SUPPORT VEHICLE  
CONSTRUCTION

ADVANCED  
WEAPONS  
AND EQUIPMENT

INDEX

RECORD SHEETS





The *Total Warfare (TW)* and *TechManual (TM)* rulebooks present the core game and construction rules for *Classic BattleTech (CBT)*, otherwise referred to as the standard rules. These two volumes encompass eight core unit types—several of which contain numerous sub-unit types—and a host of weapons and rules, as well as covering many different game situations. However, despite the breadth of play covered, many game situations still fall outside those rules, not to mention a plethora of more advanced equipment, as well as a few advanced units.

## ADVANCED RULES

Beyond the standard rules, a legion of advanced rules exists, allowing players to expand their games in any direction they desire. In an effort to bring these rules to players in the most logical form possible, the advanced rules are contained in three core rulebooks, each one staging up and building off of the previous rules set. Additionally, each one focuses on a particular “in-universe time frame” that will allow players to easily grasp where a given rulebook will “plug into” their existing game play.

### TACTICAL OPERATIONS

#### SitRep:

**Forces on-world.**

**Conflict expected to last mere hours to achieve object.**

*Classic BattleTech Tactical Operations (TO)* is the rulebook you are holding in your hands, and is the first in the “staging” Advanced Rulebooks. Its focus is during game play, and applies directly to a game as it unfolds on a world in the *BattleTech* universe; its rules represent hours in-universe, the time frame it takes for a single, moderate-sized battle to play out on a gaming table.

Building on *Total Warfare* and *TechManual*, *Tactical Operations* conveys numerous advanced rules for movement and combat across various units, while expanding core rules such as those for buildings, and implementing a host of advanced terrain and weather rules. Rules for the construction and use of advanced Support Vehicles are presented, as well as advanced and prototype construction options and weapons for use by almost every unit.

This book contains a number of rules changes from previous editions. We feel confident that these are the most complete, clear and concise advanced rules for *Classic BattleTech* ever presented.

These rules supersede all previously published rules, including the *BattleTech Manual*, *BattleTech Compendium*, *BattleTech Compendium: The Rules of Warfare*, *BattleTech Master Rules* (standard and revised editions), *Combat Equipment*, *Tactical Handbook*, *Maximum Tech* (standard and revised editions) and *Unbound*.

To use the construction rules, designers will need paper and pencils, as well as copies of the Blank Record Sheets found at the back of this book. Due to the complexities involved with the construction of the Advanced Support Vehicles, a calculator will be handy as well.

### STRATEGIC OPERATIONS

#### SitRep:

**Forces in solar system.**

**Beginning burn to planet.**

**Conflict expected to last weeks to achieve object.**

*Classic BattleTech Strategic Operations (SO)* is the second “staging” Advanced Rulebook. It stages a player up to the next logical area of play, focusing on “in a solar system” and multi-game play; its rules represent weeks within the *BattleTech* universe, the time frame needed for several battles to conquer an entire solar system.



*Strategic Operations* contains advanced movement and combat operations emphasizing the importance of aerospace units, while extensive rules cover combat drops of numerous troop types into any situation. Linked scenarios and comprehensive maintenance, salvage, repair and customization rules provide an easy format for players to turn multiple games into an interconnected campaign to capture a target system, where the support crew of technicians and doctors and their skills can be just as important as any warrior. Complete game play and construction rules for advanced aerospace units are also included. Finally, a complete game system—*BattleForce*—allows players to use their existing miniatures and mapsheets to play quick, fast-paced *BattleTech* games, from small-scale skirmishes to large-scale planetary invasions.

## INTERSTELLAR OPERATIONS

### SitRep:

**Forces marshaled.**

**Flotillas assigned to target solar systems.**

**Conflict expected to last months to achieve objects.**

*Classic BattleTech Interstellar Operations (IO)* is the third and final “staging” Advanced Rulebook. Players are staged up to the final level of play, where they can assume the roles of a House Lord or Clan Khan and dominate the galaxy; *IO* rules represent months in the *BattleTech* universe, the time frame for conquering numerous star systems.

*Interstellar Operations* contains complete rules for generating and running any type or size of force, as well as the *BattleTech Strategic Game: The Inner Sphere in Flames*. This comprehensive rules set governs the running of an entire faction’s military as a player tries to conquer (or defend) numerous solar systems. More importantly, the Strategic Game contains rules that allow players to stage any portion of a given conflict back through the various rule sets, as they desire—from the simple, easy-to-use rules of conflict for the Strategic Game, down to *BattleForce*, or all the way back down to a standard *BattleTech* game as presented in *Total Warfare* and *Tactical Operations*. Players have complete flexibility for any type of conflict in which they wish to engage.

## CHOOSE YOUR RULES

*Tactical Operations* encapsulates a myriad of advanced rules. In effect, all the rules and weapons/equipment in this volume are optional. This means you can use as many or as few of the rules in this book as you want. (In fact, this book contains so many new rules that we recommend you try them out a few at a time, rather than attempting to use them all at once.) Furthermore, most of the new rules and equipment here can be added individually to a standard game. You can add rules and pieces of equipment to your game one at a time—most of the rules do not rely on other rules in this book to work in existing *Classic BattleTech* games. This allows you to tailor your *BattleTech* game to your taste by including only those rules that you find make the game more interesting or fun. Use whatever new rules and equipment you want and disregard the rest. Given the scope of the rules and the fact that they are optional, all players in a group should read through and agree to the use of any of these rules and weapons/equipment.

## PLAYER ADJUDICATION

An advanced-rules book for any game is, almost by definition, more complex. In a game system with such a long and rich heritage as *Classic BattleTech*—this rulebook alone draws from dozens of different sources across a large number of years—that complexity is even greater. Developers and writers have gone to great effort to make these rules as comprehensive as possible—not only from one section to the next in this book, but in how such advanced weapons and rules interact with the core game and construction rules as presented in *Total Warfare* and *TechManual*. However, the sheer scope of *Tactical Operations* and the plethora of options provided (both in advanced rules and in the more than 100 pages of advanced weapons and equipment) means that it is not possible to cover all potential situations. Once this product reaches the players’ hands, they’ll envision scenarios and create situations on a game board that never crossed the minds of the developers or the legion of authors and playtesters that thoroughly worked over this product.

With that in mind, when players encounter situations not covered in the rules as they integrate the contents of *Tactical Operations* into their playing group, they are encouraged to adjudicate each situation appropriately; make up the rules that work for you. If in the process a playing group runs into an argument, feel free to let a die roll resolve any disputes so you can return to playing the game and having fun.

Finally, the forums on [www.classicbattletech.com](http://www.classicbattletech.com) are an excellent resource. Players can join a strong and vibrant online community, tapping a wide selection of players for different ideas on how best to adjudicate a particular situation.

## FICTION

As described in *Total Warfare* and *TechManual*, fiction plays a pivotal role in bringing the *Classic BattleTech* universe to life. Whether “story fiction” that places readers inside the heads of the characters in that universe, or “sourcebook fiction” that places the reader in the universe as though living among those characters, both work hand-in-hand to immerse players in this vibrant milieu.

*Total Warfare* concentrated on story fiction, while *TechManual* concentrated on sourcebook fiction. *Tactical Operations* covers something of a middle ground, with various story and sourcebook fiction sections found throughout the book.

### FICTION VS. RULES

It is important to remember that regardless of the critical role fiction plays in immersing players in the *Classic BattleTech* universe, such fiction should never be construed as rules. As with *Total Warfare* and *TechManual*, to eliminate confusion about which sections are fiction and which are rules, the fiction sections have a unique look, compared to the uniform presentation of the various rules sections. All fiction sections are italicized in the table of contents.

As with *TechManual*, the exception is the *Equipment* section, which includes sourcebook fiction as well as rules. In this case, the sourcebook fiction entries for each piece of equipment are set apart in a distinctive graphic presentation, allowing readers to tell at a glance what is fiction and what are rules.

INTRODUCTION

ADVANCED  
GROUND MOVEMENT

ADVANCED  
COMBAT

ADVANCED  
BUILDINGS

ADVANCED  
SUPPORT  
VEHICLES

GENERAL  
RULES

ADVANCED  
SUPPORT VEHICLE  
CONSTRUCTION

ADVANCED  
WEAPONS  
AND EQUIPMENT

INDEX

RECORD SHEETS



## FICTION VS. ART

*Tactical Operations* follows the graphic design format established by *Total Warfare* and *TechManual*, wedding art to the book's visual presentation in order to enhance the players' experience. In this case, the graphic presentation represents a computer from House Davion's New Avalon Institute of Science, one of the Inner Sphere's largest and most advanced universities for the study and development of new technologies (see *A Time of War*, p. 17, *TW*).

As with fiction, while art plays an important role in bringing the *Classic BattleTech* universe to life, it should never be construed as rules.

## COMPONENTS

Page 26 of *Total Warfare* (as well as p. 13 of *TM*) discusses several Support Vehicles that exist in the *Classic BattleTech* universe, but fall outside the purview of the standard-rules game and construction rulebooks. Those units are discussed here.

### SUPPORT VEHICLES

In addition to the Support Vehicles described on page 25 of *Total Warfare*, the *Classic BattleTech* universe also includes Satellites and Rail systems.

**Note:** Game and construction rules for Large Airships and Large Naval Support Vehicles are not covered in *Total Warfare* or *TechManual*—though the Small- and Medium-sized classes of both unit types are covered in those volumes—but instead appear in this rulebook.

#### Satellites

Used for communications, surveying and information-gathering—and often for spying during battles—Satellites rely on station-keeping drives and lack the powerful propulsion systems that would make them true spacecraft.

#### Rail Systems

Rail systems transport cargo and passengers over land. Standard Rail requires little technology to produce or maintain, but advanced maglev systems (which require a much higher level of technology) achieve far greater speed by suspending the train above the track and propelling it with powerful magnetic fields.

### MOBILE STRUCTURES

An exceptionally rare sight in the *Classic BattleTech* universe, Mobile Structures represent super-large units and mobile buildings. Such unique constructs are usually reserved for wealthy planets that can afford such extravagance (such as super-large wet-navy container ships, or

DropShip transports), or specialized planetary environments, where the costs of construction and maintenance are outweighed by the needs of survival, or the desire to plumb harsh environmental locations for rare minerals and so on.

## RECORD SHEETS

Players use the following record sheets to track various types of information while playing *BattleTech*. Each type of unit (JumpShips, WarShips, Space Stations, Satellites, Mobile Structures and Large Naval Support Vessels) uses a unique record sheet, while Rail and Large Airship Support Vehicles use Combat Vehicle Record Sheets appropriate to the unit type. Blank Record Sheets are provided at the back of this rulebook for all unit types. How they work, and which record sheets should be used for each unit type featured in this book are outlined below.

#### Construction

As noted in *TechManual*, at the end of the design process for any construction rules presented in this volume, each designer must translate his or her unit from its raw statistics to an appropriate record sheet in order to use it properly in a game of *Classic BattleTech*.

#### LARGE NAVAL VEHICLE RECORD SHEET

The Large Naval Vehicle Record Sheet has much in common with the Naval Vehicle Record Sheet. Therefore, only those sections unique to the Large Naval Vehicle Record Sheet are discussed below.

#### Critical Damage

In addition to the standard critical damage tracked by Small- and Medium size-class Naval Vessels, the Large Naval Vessel includes the various turrets that can be mounted on such a unit.

#### Armor Diagram

While a standard Naval Vehicle divides its Armor Diagram into five sections (Front, Right, Left, Rear and Turret), a Large Naval Vehicle has six locations (Front, Left Front, Right Front, Left Rear, Right Rear and Rear) as well as the potential for eight turrets (see *Tables*, below).

#### Tables

In place of the standard tables displayed on all vehicle record sheets, the bottom left of the record sheet includes the armor and internal structure for the eight turrets that a Large Naval Vessel can mount.



Satellite



Rail System

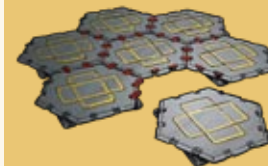

Mobile Structure



**CLASSIC BATTLETECH**

**LARGE NAVAL VESSEL RECORD SHEET**

**VEHICLE DATA**

Type: \_\_\_\_\_  
 Movement Points: \_\_\_\_\_  
 Cruising: \_\_\_\_\_  
 Flank: \_\_\_\_\_  
 Movement Type: \_\_\_\_\_  
 Engine Type: \_\_\_\_\_

**CREW DATA**

Crew: \_\_\_\_\_  
 Gunnery Skill: \_\_\_\_\_  
 Life Boats: \_\_\_\_\_  
 Hts Taken: 1 2 3 4 5 6  
 Modifier: +1 +2 +3 +4 +5 +6

**CRITICAL DAMAGE**

Engine Hts: \_\_\_\_\_  
 Sensor Hts: \_\_\_\_\_  
 Turbine 1 Locked \_\_\_\_\_  
 Turbine 2 Locked \_\_\_\_\_  
 Turbine 3 Locked \_\_\_\_\_  
 Turbine 4 Locked \_\_\_\_\_  
 Turbine 5 Locked \_\_\_\_\_  
 Turbine 6 Locked \_\_\_\_\_  
 Turbine 7 Locked \_\_\_\_\_  
 Turbine 8 Locked \_\_\_\_\_

**ARMOR DIAGRAM**

Front Armor  
 Left Front Armor  
 Right Front Armor  
 Rear Armor

**DEPTH TRACK**

Turn	1	2	3	4	5	6	7	8	9	10
Depth										
Depth	11	12	13	14	15	16	17	18	19	20
Depth										

© 2008 WizKids, Inc. Classic BattleTech, Mech and BattleMech are trademarks of WizKids, Inc. All rights reserved. Permission to photocopy for personal use.

**CLASSIC BATTLETECH**

**SATELLITE RECORD SHEET**

**SATELLITE DATA**

Type: \_\_\_\_\_  
 Thrust: \_\_\_\_\_  
 Station Keeping Only \_\_\_\_\_  
 Tonnage: \_\_\_\_\_  
 Tech Base: \_\_\_\_\_  
 Clan \_\_\_\_\_  
 Inner Sphere \_\_\_\_\_

**WEAPONS & EQUIPMENT INVENTORY**

Weapon Name: \_\_\_\_\_  
 Qty Type: \_\_\_\_\_  
 Loc: Hc SRV MRV LRV ERV

**CREW DATA**

Gunnery Skill: \_\_\_\_\_  
 Hts Taken: 1 2 3 4 5 6  
 Modifier: +1 +2 +3 +4 +5 +6

**CRITICAL DAMAGE**

Avionics: \_\_\_\_\_  
 CIC: \_\_\_\_\_  
 Sensors: \_\_\_\_\_  
 Life Support: \_\_\_\_\_  
 Thrusters: \_\_\_\_\_

**HEAT DATA**

Heat Sinks: \_\_\_\_\_  
 Heat Generation Per Arc: \_\_\_\_\_  
 Single \_\_\_\_\_  
 Double \_\_\_\_\_

**ARMOR DIAGRAM**

Nose Damage Threshold (Total Armor) \_\_\_\_\_  
 Left Damage Threshold (Total Armor) \_\_\_\_\_  
 Right Damage Threshold (Total Armor) \_\_\_\_\_  
 Aft Damage Threshold (Total Armor) \_\_\_\_\_

**DEPTH TRACK**

Turn	1	2	3	4	5	6	7	8	9	10
Depth										
Depth	11	12	13	14	15	16	17	18	19	20
Depth										

© 2008 WizKids, Inc. Classic BattleTech, Mech and BattleMech are trademarks of WizKids, Inc. All rights reserved. Permission to photocopy for personal use.

**SATELLITE RECORD SHEET**

The Satellite Record Sheet has much in common with the Aerodyne DropShip Record Sheet. Therefore, only those sections unique to the Satellite Record Sheet are discussed below.

**Unit Data**

A satellite does not have a Safe or Maximum Thrust, but only a Station-Keeping Thrust, which is why no Velocity Track appears on the record sheet.

**Critical Damage**

Only critical damage that applies to a Satellite is included here.

**STRUCTURE RECORD SHEET**

The Structure Record Sheet is for use when constructing a building (see *Building Construction*, p. 128), or when using the expanded Construction Factor rules (see p. 121) with standard buildings. This record sheet is also used when dealing with Mobile Structures (see p. 165).

**Structure Map**

In advanced-rules play, several rules options require tracing specific building hexes vertically and horizontally. Additionally, the Structure Map is designed to help players create truly large structures using multiple record sheets. For example, Record Sheet A could track Levels 1 to 6, while Record Sheet B could track the same horizontal area from Levels 7 to 12. On Record Sheet C, the players may add a "right side" to the sheet to show that the horizontal locations of these building hexes are conjoined exactly to the right of Record Sheet A, and so on.

**Structure Data**

The Structure Data block is located in the upper left corner of the record sheet and includes the total levels of the structure, what technology base was used when constructing the building, and the Weapons Inventory for tracking what weapons a building may mount; weapons of identical types and location may be combined on a single line to conserve space (ammunition is noted on a separate line). The Cost and Battle Value of the building can also be noted in this location.

For Mobile Structures, this section also tracks the MP, Movement Type and Powerplant Type.

**CF and Armor**

The CF & Armor block is located in the bottom left of the record sheet and includes a double column for tracking the Construction Factor and Armor of various hexes. Note that this section is not designed to track all hexes (the Structure Map accomplishes that task), but to track those specific hexes that have been damaged during play.

**Crew Data**

This block lists the number of crew and their Gunnery Skill.

**ADVANCED RULES RECORD SHEETS**

The following record sheets are modifications of standard-rules record sheets found in *TechManual*. The changes allow a player to more easily track the many new weapons/equipment options and rules during game play. This section only covers changes made to the record sheets.

INTRODUCTION

ADVANCED GROUND MOVEMENT

ADVANCED COMBAT

ADVANCED BUILDINGS

ADVANCED SUPPORT VEHICLES

GENERAL RULES

ADVANCED SUPPORT VEHICLE CONSTRUCTION

ADVANCED WEAPONS AND EQUIPMENT

INDEX

RECORD SHEETS



**CLASSIC BATTLETECH** WK GAMES

**STRUCTURE RECORD SHEET** **STRUCTURE MAP**

**MECH DATA**  
 Description: \_\_\_\_\_ Levels: \_\_\_\_\_  
 MP: \_\_\_\_\_ Tech Base: \_\_\_\_\_  
 Movement Type: \_\_\_\_\_ Clan \_\_\_\_\_  
 Powerplant Type: \_\_\_\_\_ Inner Sphere \_\_\_\_\_  
**Weapons & Equipment Inventory** (hexes)  
 Bay Type Hex/Cat Dmg Min Shc Med Lg Level: \_\_\_\_\_

**CF & ARMOR**  
 Hex CF Armor Hex CF Armor Level: \_\_\_\_\_

**CREW DATA**  
 Crew: \_\_\_\_\_ Gunnery Skill: \_\_\_\_\_ Level: \_\_\_\_\_

© 2008 WizKids, Inc. Classic BattleTech, Mech and BattleMech are trademarks of WizKids, Inc. All rights reserved. Permission to photocopy for personal use.

**Note:** Despite the best efforts to provide as much information as possible for the advanced-rules record sheets, the sheer scale of options found in *Tactical Operations* makes it virtually impossible to provide a sheet that can cover every possibility. Players can use a *Notes* section of a given record sheet, or simply use the back, to track any options in use not covered on the record sheet.

**Advanced 'Mech and Four-Legged 'Mech Record Sheets**  
 The following describes the changes made to the standard 'Mech and Four-Legged 'Mech Record Sheets.

**'Mech Data:** Includes notes for tracking a 'Mech's Sprinting MP and whether it utilizes a Mixed technology base, and allows for tracking of whether or not an LRM is hot-loaded.

**Warrior Data:** Includes data for two warriors, as well as boxes for tracking the status of the auto ejection system.

**Critical Hit Table:** Additional critical slot items are gray-scaled to show that a 'Mech may be constructed without those items. Additionally, boxes to note the mounting of turrets or a full head ejection system are also noted, as are circles next to every critical slot, for use when using the armored component rule.

**Heat Data and Heat Scale:** These items have been expanded to increase the Heat Scale from 30 to 50.

**Notes:** In place of the cockpit illustration (or blank *Notes* section), a host of equipment options are noted for ease of tracking during construction and game play.

**CLASSIC BATTLETECH** WK GAMES

**ADVANCED 'MECH RECORD SHEET**

**MECH DATA**  
 Movement Points: \_\_\_\_\_ Tonnage: \_\_\_\_\_  
 Walking: \_\_\_\_\_ Tech Base: \_\_\_\_\_  
 Running: \_\_\_\_\_ Clan \_\_\_\_\_  
 Sprinting: \_\_\_\_\_ Inner Sphere \_\_\_\_\_  
 Jumping: \_\_\_\_\_ Mixed \_\_\_\_\_

**WARRIOR DATA**  
 Name: \_\_\_\_\_ Gunnery Skill: \_\_\_\_\_ Piloting Skill: \_\_\_\_\_  
 Hits Taken: 1 2 3 4 5 6  
 Critical Hits: 3 5 7 10 11 (Dead)  
 Name: \_\_\_\_\_ Gunnery Skill: \_\_\_\_\_ Piloting Skill: \_\_\_\_\_  
 Hits Taken: 1 2 3 4 5 6  
 Critical Hits: 3 5 7 10 11 (Dead)

**WEAPONS & EQUIPMENT INVENTORY** (hexes)  
 Bay Type Loc Hs Dmg Min Shc Med Lg

**INTERNAL STRUCTURE DIAGRAM**  
 Left Torso ( ) Head ( ) Right Torso ( )  
 Left Arm ( ) Center Torso ( ) Right Arm ( )  
 Left Leg ( ) Center Torso ( ) Right Leg ( )  
 Left Torso Rear ( ) Right Torso Rear ( )

**HEAT DATA**  
 Heat Sink: \_\_\_\_\_  
 Heat Scale: \_\_\_\_\_

**CRITICAL HIT TABLE**  
 Left Arm: 1.0 Shoulder, 2.0 Upper Arm Actuator, 3.0 Lower Arm Actuator, 4.0 Wrist Actuator  
 Right Arm: 1.0 Shoulder, 2.0 Upper Arm Actuator, 3.0 Lower Arm Actuator, 4.0 Wrist Actuator  
 Center Torso: 1.0 Engine, 2.0 Engine, 3.0 Engine, 4.0 Gyro, 5.0 Gyro, 6.0 Gyro  
 Left Torso: 1.0 Gyro, 2.0 Engine, 3.0 Engine, 4.0 Gyro, 5.0 Gyro, 6.0 Gyro  
 Right Torso: 1.0 Gyro, 2.0 Engine, 3.0 Engine, 4.0 Gyro, 5.0 Gyro, 6.0 Gyro  
 Left Leg: 1.0 Hip, 2.0 Upper Leg Actuator, 3.0 Lower Leg Actuator, 4.0 Foot Actuator, 5.0, 6.0  
 Right Leg: 1.0 Hip, 2.0 Upper Leg Actuator, 3.0 Lower Leg Actuator, 4.0 Foot Actuator, 5.0, 6.0

© 2008 WizKids, Inc. Classic BattleTech, Mech and BattleMech are trademarks of WizKids, Inc. All rights reserved. Permission to photocopy for personal use.

**Advanced Ground Vehicle and VTOL Record Sheets**

The following describes the changes made to the standard Ground Vehicle and VTOL record sheets.

**Crew Data:** Includes data for tracking crew size.

**Armor Diagram:** The Armor Diagrams have been expanded, as appropriate. Areas for tracking armor and internal structure for additional turrets have also been added.

**Hit Location and Critical Hits Table (VTOL Only):** Appropriate information has been added for tracking damage and critical hits against a turret.

**Advanced Conventional Infantry Record Sheet**

The following describes the changes made to the standard Conventional Infantry Record Sheet.

**Range Modifier:** This section has been expanded significantly to track many of the different weapon options available to advanced-rules infantry.

**Skills:** This area also now tracks Experience, and includes a notes section.

**Armor:** Armor Type (including a unit's Damage Divisor, if greater than 1) can now be tracked on the sheet.

**Tables:** The Morale and Recovering Nerve Tables are found on the sheet for ease of use during a game.



INTRODUCTION

ADVANCED GROUND MOVEMENT

ADVANCED COMBAT

ADVANCED BUILDINGS

ADVANCED SUPPORT VEHICLES

GENERAL RULES

ADVANCED SUPPORT VEHICLE CONSTRUCTION

ADVANCED WEAPONS AND EQUIPMENT

INDEX

RECORD SHEETS

**CLASSIC BATTLETECH** **ADVANCED CONVENTIONAL INFANTRY RECORD SHEET**

**CONVENTIONAL INFANTRY: PLATOON / POINT 1** Armor Type: \_\_\_\_\_ Divisor: \_\_\_\_\_

Experience: \_\_\_\_\_ Gunny Skill: \_\_\_\_\_ Anti-Mech Skill: \_\_\_\_\_ Max Weapon Damage\* \_\_\_\_\_

Notes: \_\_\_\_\_

Range Modifier: 0 1 2 3 4 5 6 7 8 9 10 11 12 13 14 15 16 17 18 19 20 21

Field Gun Type: \_\_\_\_\_ Ammo: \_\_\_\_\_ Disposable Weapon: \_\_\_\_\_ Ammo: \_\_\_\_\_

Movement MP: \_\_\_\_\_ Type: \_\_\_\_\_

---

**CONVENTIONAL INFANTRY: PLATOON / POINT 2** Armor Type: \_\_\_\_\_ Divisor: \_\_\_\_\_

Experience: \_\_\_\_\_ Gunny Skill: \_\_\_\_\_ Anti-Mech Skill: \_\_\_\_\_ Max Weapon Damage\* \_\_\_\_\_

Notes: \_\_\_\_\_

Range Modifier: 0 1 2 3 4 5 6 7 8 9 10 11 12 13 14 15 16 17 18 19 20 21

Field Gun Type: \_\_\_\_\_ Ammo: \_\_\_\_\_ Disposable Weapon: \_\_\_\_\_ Ammo: \_\_\_\_\_

Movement MP: \_\_\_\_\_ Type: \_\_\_\_\_

---

**BURST-FIRE WEAPON DAMAGE VS. CONVENTIONAL INFANTRY TABLE**

**WEAPONS, PROTOMECHS AND VEHICLES**

WEAPON	DAMAGE vs. CONVENTIONAL INFANTRY
All Grenade Rifles	100
Light Machine Gun	100
Machine Gun	100
Heavy Machine Gun	200
Snail/Micro Pulse Laser	400
Flame	400

**BATTLE ARMOR**

WEAPON	DAMAGE vs. CONVENTIONAL INFANTRY
Light Machine Gun	100/2 (round up)
Machine Gun	100
Heavy Machine Gun	200
Flamer	200
Light Recessless Rifle	100
Medium Recessless Rifle	200
Heavy Recessless Rifle	400
Light Mortar	100
Heavy Mortar	200
Automatic Grenade Launcher	100/2 (round up)
Heavy Grenade Launcher	100

**NON-INFANTRY WEAPON DAMAGE AGAINST INFANTRY**

WEAPON TYPE*	NUMBER OF CONVENTIONAL INFANTRY (ROUNDER HIT)
Light Fire (Ballistic or Energy)	1
Cluster (Ballistic)	Damage Value / 10
Pistol**	Damage Value / 10 + 1
Cluster (Missile)	Damage Value / 10 + 2
Burst-Fire	See Burst-Fire Weapons Table
Heat Effect (ME)	Damage Value / 10
Heat Effect (Weapons)	See Heat Effect Weapons

**MORALE TABLE**

Level	Morale Target	Morale Target	Morale Target
Green	0	5	10
Regular	2	5	7
Veteran	-5	2	4
Elite	-5	2	2

**ATTACK SOURCE MODIFIER (INFANTRY ONLY)**

Standstill in LOS	+1
Artillery	+2
Flame or Fire	+2

**OTHER MODIFIERS (CONVENTIONAL INFANTRY ONLY)**

Broken Armor	+1
Commander Modifier	+1
Light or Medium Battle Armor Link	-1
Heavy or Assault Battle Armor Link	-2
Anti-Mech Skill of 5 or less	-1
Conventional Infantry with Armor (see p. 217)	-2
Unit in Building	-2

**RECOVERING NERVE TABLE**

COMMANDER*	Subordinate Commander in LOS
1	-2
2	-1
3	0
4	+1
5	+2
6	+3

**INFANTRY ONLY**

Priority Non-Building, non-artillery unit in LOS	+1
Priority Mech in LOS	+2
Another Assault Infantry unit in LOS	+1
Another Assault Non-artillery Unit in LOS	+2
Routed Unit	-3

\* Only applies if Commander score is 10% or less.

**WotK GAMES**

**CLASSIC BATTLETECH** **SUPER-HEAVY VEHICLE RECORD SHEET**

**VEHICLE DATA**

Type: \_\_\_\_\_ Tonnage: \_\_\_\_\_ Tech Base: \_\_\_\_\_

Movement Points: \_\_\_\_\_ Tech Base: \_\_\_\_\_

Crushing: \_\_\_\_\_ Tech Base: \_\_\_\_\_

Flank: \_\_\_\_\_ Inner Sphere: \_\_\_\_\_

Movement Type: \_\_\_\_\_

Engine Type: \_\_\_\_\_

**CREW DATA**

Crew: \_\_\_\_\_

Gunny Skill: \_\_\_\_\_ Driving Skill: \_\_\_\_\_

Commander Hit: \_\_\_\_\_ Driver Hit: \_\_\_\_\_

Mechanic Hit: \_\_\_\_\_ Motorist Hit: \_\_\_\_\_

Stall Hit: \_\_\_\_\_

**CRITICAL DAMAGE**

Front Turret Locked: \_\_\_\_\_ Engine Hit: \_\_\_\_\_

Rear Turret Locked: \_\_\_\_\_ Stabilizer: \_\_\_\_\_

Sensor Hits: \_\_\_\_\_

Motive System Hits: \_\_\_\_\_

Front: \_\_\_\_\_ Left: \_\_\_\_\_ Right: \_\_\_\_\_

Rear: \_\_\_\_\_ Fl. Turret: \_\_\_\_\_ Rr. Turret: \_\_\_\_\_

**NOTES**

Cost: \_\_\_\_\_ BV: \_\_\_\_\_

**ARMOR DIAGRAM**

**WotK GAMES**

---

**VEHICLE DATA**

2D6 Roll: \_\_\_\_\_

ATTACK DIRECTION	FRONT SIDE	REAR SIDE
Front (orbital)	Side (orbital)	Side (orbital)
Rear (orbital)	Side (orbital)	Side (orbital)
Front (orbital)	Side (orbital)	Side (orbital)
Rear (orbital)	Side (orbital)	Side (orbital)
Front (orbital)	Side (orbital)	Side (orbital)
Rear (orbital)	Side (orbital)	Side (orbital)
Front (orbital)	Side (orbital)	Side (orbital)
Rear (orbital)	Side (orbital)	Side (orbital)
Front (orbital)	Side (orbital)	Side (orbital)
Rear (orbital)	Side (orbital)	Side (orbital)
Front (orbital)	Side (orbital)	Side (orbital)
Rear (orbital)	Side (orbital)	Side (orbital)

**MOTIVE SYSTEM DAMAGE TABLE**

2D6 Roll	EFFECT*
0-2	No Effect
3-4	Minor damage, +1 modifier to all Driving Skill rolls
5-6	Major damage, -1 Driving MP, +2 modifier to all Driving Skill rolls
7-8	Major damage, only half Driving MP found fractions left
9-10	+2 modifier to all Driving Skill rolls
11-12	Major damage, no movement for the rest of the game

**Attack Direction Modifier:** +1 Tracked, +2 Tracked, +3 Tracked, +4 Tracked

**Vehicle Type Modifiers:** +1 Tracked, +2 Tracked, +3 Tracked, +4 Tracked

**WotK GAMES**

---

**SUPER-HEAVY VEHICLE CRITICAL HITS TABLE**

2D6 Roll	FRONT	SIDE	REAR	TURRET
2-5	No Critical Hit	No Critical Hit	No Critical Hit	No Critical Hit
6	Driver Hit	Cargo/Infantry Hit	Weapon Malfunction	Stabilizer
7	Weapon Malfunction	Cargo/Infantry Hit	Weapon Malfunction	Turret/Jam
8	Stabilizer	Crew Scuttled	Stabilizer	Weapon Malfunction
9	Sensors	Stabilizer	Weapon Destroyed	Turret Locks
10	Commander Hit	Weapon Destroyed	Engine Hit	Weapon Destroyed
11	Weapon Destroyed	Engine Hit	Ammunition**	Ammunition**
12	Crew Killed	Fuel Tank*	Fuel Tank*	Turret Blow Off

\* If Combat Vehicle has ICE engine only, if Combat Vehicle has a fusion engine, treat this result as Engine Hit.

\*\* If Combat Vehicle carries no ammunition, treat this result as Weapon Destroyed.

**WotK GAMES**

Super-Heavy Vehicle Record Sheet

The Super-Heavy Vehicle Record Sheet allows players to construct and play with Combat Vehicles in excess of the standard-rules weight restrictions. Details on the game play and construction of such units are found on p. 378. The Super-Heavy Vehicle Record Sheet has much in common with the standard-rules Ground Vehicle Record Sheet. Therefore, only those sections unique to the Super-Heavy Vehicle Record Sheet are discussed below.

**Armor Diagram:** While a standard Ground Vehicle divides its Armor Diagram into five sections (Front, Right, Left, Rear and Turret), a Super-Heavy Vehicle has six locations (Front, Left Front, Right Front, Left Rear, Right Rear and Rear) as well as the potential for two turrets.

**Tables:** The Super-Heavy Vehicle Hit Location Table takes into account the additional hit locations for such a vehicle.

ADDITIONAL RECORD SHEETS AND TEMPLATES

The following additional record sheets are also found at the end of this rulebook, but are described elsewhere in this volume.

Double Blind Turn Record Sheet

This record sheet is for use with the Double-Blind Rules (see p. 220).

Large Naval Template

This is not a record sheet in the normal sense of the word, as it is not used to track unit information during game play. Instead, it is a template used in conjunction with Large Naval Vessel Support Vehicles (see p. 154) and grounded Large Airship Support Vehicles (see p. 164) during game play.

Line of Sight Chart

This record sheet is for use with the advanced Line of Sight and Dead Zones rules (see p. 79).

Mobile Structure Template

This is not a record sheet in the standard use of that word in the BattleTech game system. Instead, this record sheet is provided as a way to easily photocopy and cut out whatever sized Mobile Structure template a player desires for use on the playing area (see Mobile Structures, p. 165).

Simultaneous Movement Record Sheet

This record sheet is for use with the Simultaneous Movement rules (see p. 215).

# TACTICAL ANALYSIS

It would be a waste of valuable time and resources to recap the history of military tactical and industrial development, especially in light of the current conflict. Suffice to say, in the centuries since the rise and fall of the first and only true Star League, humankind has been battered back to the brink of technological collapse, only to see the dawn of a tainted renaissance. The recovery of the Gray Death Memory Core unlocked the technologies lost centuries before—and almost too late to level the playing field between the Inner Sphere and the coming Clan threat. Militarily, this accomplishment brought with it more than a mere hope for survival, however. It also unleashed new ambitions that verged on drying out from the exhaustion of the Succession Wars: the hunger for universal conquest, the rebirth of humankind's Golden Age under the banner of a single House.

Only the Clans' arrival would forestall a Fifth Succession War—and would even, briefly, unite the Great Houses against a common foe long enough to give birth to a new Star League. But in the end, the inevitable bickering and distrust resurfaced, and the armies of the Inner Sphere once more marched against each other, even with the Clan threat looming ominously above. And so, less than fifty years after the close of the last Succession War, amid the smoke of a dozen and more new wars—great and small—the armies of the Inner Sphere and the forces of the Clan juggernaut once more stood on the brink of an all-engulfing conflict, fueled by an arms race not seen since the days of the Terran Hegemony. The promise of a new age under a new Star League—an age where the rediscovery of the glorious knowledge of our civilization's peak promised an end to human suffering—was dashed anew by the petty rivalries of an old order.

And in a fit of blinding rage came the Word of Blake Jihad, a war against everyone, everywhere.

Amid the turmoil of this conflict, it is still difficult to gauge its full effects. Even now, nearly eight years later, the overall strength of the Inner Sphere and Clan militaries can only be guessed at, while the devastating effects on major military industries across human-occupied space can only be suggested. For some powers, even the identity of their military leaders remains unclear. And all the while the tech race resumes, as desperate armies clamor for any weapon they can find to stem the tides of chaos.

This is the Inner Sphere of today—a universe once again at war, locked in the throes of chaos and despair.

—Logan DeMarco,

*INN Military Industrial Analyst, Arc-Royal,*

*14 November 3075*

## HOUSE STEINER (LYRAN ALLIANCE)

MOST PROMINENT CENTER OF INNOVATION (3067)		New Cambridge University of Wessex	
MAJOR DEFENSE INDUSTRIES (3067)		Arc-Royal MechWorks, Blackstone BattleMechs, Ltd., Bowie Industries, Brigadier Corporation, Coventry Metal Works, Cyclops Incorporated, Defiance Industries, Gienah Combat Vehicles, Lockheed/CBM Corporation, New Earth Trading Company, Quikscell Company, Semier Data Tron, Shipil Company, StarCorps Industries, TharHes Industries, Tharkad Aerospace Group, Yankee Weapons Systems	
MOST RECENT INNOVATIONS		Ultra AC/20 (3060), Heavy Gauss Rifle (3061), Bombast Laser (3064*), M-Pod (3064*), Improved Heavy Gauss (3065*), Chaff Pod (3069*), Thunderbolt Launcher (3072)	
Tech Rating	E	First Rediscovered	XL Engine (3035)
		Latest Innovation	Thunderbolt Launcher

GREAT HOUSE

## HOUSE MARIK (FREE WORLDS LEAGUE)

MOST PROMINENT CENTER OF INNOVATION (3067)		Free Worlds Technical Institute	
MAJOR DEFENSE INDUSTRIES (3067)		Andurien Aerotech, Brigadier Corporation, Brooks Incorporated, Corean Enterprises, Deller, Bingham and Fouts, Earthwerks Incorporated, Exeter Organization, Gibson Federated BattleMechs, Grumman Amalgamated, Imstar AeroSpace, Irian BattleMechs Unlimited, Kali Yama / Alphard Trading Corp., Kali Yama Weapons Industries Inc., Kallon Industries, Ronin Inc., Nimakachi Fusion Products Ltd., Quikscell Company	
MOST RECENT INNOVATIONS		Light Gauss Rifle (3056), Ultra AC/2 (3057), Ultra AC/10 (3057), Variable-Speed Pulse Lasers (3070)	
Tech Rating	E	First Rediscovered	Artemis IV FCS (3035)
		Latest Innovation	Variable-Speed Pulse Lasers

GREAT HOUSE

## LEGEND

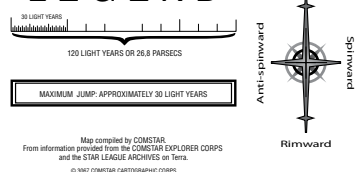

### GHOST BEAR DOMINION

MOST PROMINENT CENTER OF INNOVATION (3067)	Scientist Caste (Scientist-General Jorge [Agassiz])		
MAJOR DEFENSE INDUSTRIES (3067)	Alshain Weapons, Benson and Bjorn, Bergan Industries, Joint Equipment Systems		
MOST RECENT INNOVATIONS	Hardened Armor (3061*), Reactive Armor (3065*)		
Tech Rating	F	First Rediscovered	None
		Latest Innovation	Reactive Armor

GLAN

### CLAN JADE FALCON

MOST PROMINENT CENTER OF INNOVATION (3067)	Scientist Caste (Scientist-General Renata [Salk])		
MAJOR DEFENSE INDUSTRIES (3067)	Olivetti Weaponry, Red Devil Industries, Trelshire Heavy Industries		
MOST RECENT INNOVATIONS	Laser Heat Sinks (3055), Laser Reflective Armor (3061*), BattleMech Partial Wing (3067*), ER Flamer (3067), Heavy Flamer (3067), AP Gauss Rifle (3069), BattleMech Talons (3072)		
Tech Rating	F	First Rediscovered	None
		Latest Innovation	BattleMech Talons

GLAN

### HOUSE KURITA (DRACONIS COMBINE)

MOST PROMINENT CENTER OF INNOVATION (3067)	The Imperial Institute of Technology		
MAJOR DEFENSE INDUSTRIES (3067)	BBP Industries, Buda Imperial Vehicles, Bulldog Enterprises, Galileo Instruments, Independence Weaponry, Luthien Armor Works, New Samarkand Metals, Scarborough Manufacturers, Wakazashi Enterprises, Yori 'Mech Works		
MOST RECENT INNOVATIONS	C3 Computer (3050), Medium Range Missiles (3058), Light PPC (3067), Heavy PPC (3067), Snub-Nose PPC (3067), MRM Fire Control system (3071)		
Tech Rating	E	First Rediscovered	Endo Steel Internal Structure (3035)
		Latest Innovation	MRM Fire Control system

GREAT HOUSE

### HOUSE LIAO (CAPELLAN CONFEDERATION)

MOST PROMINENT CENTER OF INNOVATION (3067)	Victoria Academy of Arms and Technology		
MAJOR DEFENSE INDUSTRIES (3067)	Aldis Industries, Bergan Industries, Ceres Metals Industries, Earthwerks Inc., Hellespont Industrials, Hellespont 'Mech Works, HildCo Interplanetary, Mujika Aerospace Technologies, Quikscell Company, Saroyan Special Production, Shengli Arms, StarCorps Industries, Tengo Aerospace		
MOST RECENT INNOVATIONS	Hyper-Velocity Autocannon (3059*), Stealth Armor (3063), Vehicular Stealth Armor (3067*), Air-Defense Arrow Missiles (3068), Light Machine Gun (3068), Plasma Rifle (3068)		
Tech Rating	D	First Rediscovered	MASC (3035)
		Latest Innovation	Plasma Rifle

GREAT HOUSE

### HOUSE DAVION (FEDERATED SUNS)

MOST PROMINENT CENTER OF INNOVATION (3067)	New Avalon Institute of Science		
MAJOR DEFENSE INDUSTRIES (3067)	Achernar BattleMechs, Cal-Boeing of Dorwinion, Corean Enterprises, Dynamico Ltd., Federated-Boeing Interstellar, General Motors, Jalastar Aerospace, Johnston Industries, Kallon Industries, Lycomb-Davion IntroTech, Quikscell Company, Salvatore Inc., Valiant Systems, Wangker Aerospace		
MOST RECENT INNOVATIONS	Rotary AC (3062), Targeting Computer (3062), Cruise Missile Artillery (3065*), Light AC (3068), Machine Gun Array (3068), MagShot (3072)		
Tech Rating	E	First Rediscovered	Double Heat Sink (3022)
		Latest Innovation	MagShot

GREAT HOUSE

\*These innovations are still classified as prototypical and have yet to reach full production.

CLAN WOLF			
MOST PROMINENT CENTER OF INNOVATION (3067)	Scientist Caste (Scientist-General Rudi [Sinclair])		
MAJOR DEFENSE INDUSTRIES (3067)	Alshain Weapons, Wolf Clan Site OZ-1		
MOST RECENT INNOVATIONS	Laser Anti-Missile System (3054*), ER Pulse Lasers (3057*)		
Tech Rating	<b>F</b>	First Rediscovered	None
		Latest Innovation	ER Pulse Lasers

CLAN

COMSTAR			
MOST PROMINENT CENTER OF INNOVATION (3067)	Unknown		
MAJOR DEFENSE INDUSTRIES (3067)	None		
MOST RECENT INNOVATIONS	Reinforced Structure (3057*), Bloodhound Active Probe (3058*), C3i Computer (3062), Improved Narc Launcher (3062)		
Tech Rating	<b>E</b>	First Rediscovered	None
		Latest Innovation	C <sup>3</sup> i Computer

MINOR POWER

CLAN WOLF (IN-EXILE)			
MOST PROMINENT CENTER OF INNOVATION (3067)	Scientist Caste (Scientist-General Del [Temin])		
MAJOR DEFENSE INDUSTRIES (3067)	WC Site 1, WC Site 3, WC Site 4		
MOST RECENT INNOVATIONS	B-Pods (3068), Endo-Composite Structure (3073*), Modular Armor (3074*)		
Tech Rating	<b>F</b>	First Rediscovered	None
		Latest Innovation	Modular Armor

CLAN

MARIAN HEGEMONY			
MOST PROMINENT CENTER OF INNOVATION (3067)	None		
MAJOR DEFENSE INDUSTRIES (3067)	Alphard Trading Corporation, Hadrian Mechanized Industries, Marian Arms, Inc		
MOST RECENT INNOVATIONS	Rocket Launcher (3064)		
Tech Rating	<b>D</b>	First Rediscovered	None
		Latest Innovation	Rocket Launcher

PERIPHERY STATE

CLAN DIAMOND SHARK			
MOST PROMINENT CENTER OF INNOVATION (3067)	Scientist Caste (Scientist-General Judy [Bland])		
MAJOR DEFENSE INDUSTRIES (3067)	Trellshire Heavy Industries, various factory ships		
MOST RECENT INNOVATIONS	Plasma Cannon (3069), Clan Rotary Autocannon (3073*)		
Tech Rating	<b>F</b>	First Rediscovered	None
		Latest Innovation	Clan Rotary Autocannon

CLAN

MAGISTRACY OF CANOPUS			
MOST PROMINENT CENTER OF INNOVATION (3067)	University of Luxen		
MAJOR DEFENSE INDUSTRIES (3067)	Alliance Aerospace Group, Detroit Consolidated Aerospace, Detroit Consolidated MechWorks, Majesty Metals and Manufacturing		
MOST RECENT INNOVATIONS	None		
Tech Rating	<b>D</b>	First Rediscovered	None
		Latest Innovation	None

PERIPHERY STATE

### LEGEND

30 LIGHT YEARS

120 LIGHT YEARS OR 26.8 PARSECS

MAXIMUM JUMP: APPROXIMATELY 30 LIGHT YEARS

Coreward

Anti-spinward

Perimeter

Rimward

Map compiled by COMSTAR. From information provided from the COMSTAR EXPLORER CORPS and the STAR LEAGUE ARCHIVES on Terra. © 1997 COMSTAR CARTOGRAPHIC CORP.

FREE RASALHAGUE REPUBLIC			
MOST PROMINENT CENTER OF INNOVATION (3067)	None		MINOR POWER
MAJOR DEFENSE INDUSTRIES (3067)	Grumium Creations, Janesek Industries, Odin Manufacturing		
MOST RECENT INNOVATIONS	None		
Tech Rating	E	First Rediscovered	
		Latest Innovation	None

CLAN SNOW RAVEN			
MOST PROMINENT CENTER OF INNOVATION (3067)	Scientist Caste (Scientist-General Charlotte [von Braun])		CLAN
MAJOR DEFENSE INDUSTRIES (3067)	Unknown		
MOST RECENT INNOVATIONS	Ferro-Lamellor Armor (3070*)		
Tech Rating	F	First Rediscovered	
		Latest Innovation	Ferro-Lamellor Armor

CLAN NOVA CAT			
MOST PROMINENT CENTER OF INNOVATION (3067)	Scientist Caste (Scientist-General David Newton)		CLAN
MAJOR DEFENSE INDUSTRIES (3067)	Irece Alpha, Irece Beta, Matabushi Inc.		
MOST RECENT INNOVATIONS	Angel ECM Suite (3058*)		
Tech Rating	F	First Rediscovered	
		Latest Innovation	Angel ECM Suite

OUTWORLDS ALLIANCE			
MOST PROMINENT CENTER OF INNOVATION (3067)	University of Alpheratz		PERIPHERY STATE
MAJOR DEFENSE INDUSTRIES (3067)	Alliance Defenders Limited, Mountain Wolf BattleMechs, United Outworlders Corporation		
MOST RECENT INNOVATIONS	None		
Tech Rating	D	First Rediscovered	
		Latest Innovation	None

WORD OF BLAKE			
MOST PROMINENT CENTER OF INNOVATION (3067)	Unknown		MINOR POWER
MAJOR DEFENSE INDUSTRIES (3067)	Aldis Industries, Blankenburg Technologies, Krupp Armaments Works, Leopard Armor, Martinson Armaments, Mitchell Vehicles, Skobel MechWorks, Yankee Weapons Systems		
MOST RECENT INNOVATIONS	Multi-Missile Launcher (3068), Void-Signature System (3070*), Chain Whip (3071*)		
Tech Rating	E	First Rediscovered	
		Latest Innovation	Chain Whip

TAURIAN CONCORDAT			
MOST PROMINENT CENTER OF INNOVATION (3067)	New Vandenburg University		PERIPHERY STATE
MAJOR DEFENSE INDUSTRIES (3067)	Pinard Protectorates Limited, Taurus Territorial Industries, Vandenburg Mechanized Industries, Wingman Enterprises, Ltd.		
MOST RECENT INNOVATIONS	Heavy Machine Gun (3068)		
Tech Rating	D	First Rediscovered	
		Latest Innovation	Heavy Machine Gun

\*These innovations are still classified as prototypical and have yet to reach full production.



*With his enemy cornered into collapsed valleys and surrounded by heavy rubble, a Roughriders Salamander pins Taurian units under ruinous fire.*

Maneuvering 'Mechs, vehicles and infantry on the battlefield is perhaps the single most important tactical consideration in *BattleTech*. In many *BattleTech* games, as throughout the history of warfare, skillful maneuvering has often been the key to victory. In *BattleTech*, all maneuvering is governed by movement rules that simulate the effects of terrain and weather conditions, the capabilities and condition of individual 'Mechs, vehicles and infantry, and other factors that affect the ability of a unit to move in battle.

This section provides optional movement and planetary conditions rules to provide greater flexibility in *BattleTech* games.

## MOVEMENT MODES

This section includes rules for new movement modes, as well as new movement capabilities such as going hull-down, climbing, jumping and more.

As per standard rules, only a single type of movement mode (noted in parenthesis below) can be chosen in a turn.

### STANDING STILL (EXPANDED: MOVEMENT MODE)

In standard rules, standing still inflicts no to-hit modifiers, either to the attacker or the defender. However, in mechanized combat speed is life, and standing still is a death warrant. To better reflect this aspect of battle, anytime a non-infantry ground unit does not expend any MP in a turn, apply a -1 to-hit modifier to all weapon and physical attacks made against that unit.

### SPRINTING (MOVEMENT MODE)

To use sprinting movement, a 'Mech must have two working hip actuators. A 'Mech's Sprinting MP is twice its current Walking/

Cruising MP. Sprinting generates 3 Heat Points per turn. Because keeping a 'Mech safely moving at such high speeds requires a MechWarrior's total concentration, a 'Mech that sprints during the Movement Phase of a turn may not make any attacks during the remainder of the turn. Additionally, the 'Mech may not spot for indirect LRM fire or artillery fire or take any other action that would normally require it to sacrifice an attack. A Sprinting unit may not move backward or enter Water hexes of Depth 1 or deeper. Finally, any Piloting Skill Roll made for a Sprinting unit suffers an additional +2 modifier.

A MechWarrior in a Sprinting unit has little spare attention to devote to avoiding enemy attacks, so any attack against a Sprinting unit receives a -1 to-hit modifier. However, the standard target-movement modifier applies.

A 'Mech equipped with MASC or a supercharger (see p. 345) may engage either or both systems and sprint during the same turn. Engaging one gives a 'Mech MP equal to its current Walking/Cruising MP multiplied by 2.5. However, any unit that tries to sprint and use MASC or a supercharger must make a successful Piloting Skill Roll (with the +2 additional modifier for Sprinting) to avoid falling; the roll is made at the end of the 'Mech's movement.

A 'Mech equipped with MASC and a supercharger may engage both systems in the same turn and sprint. Doing so gives a 'Mech MP equal to its current Walking MP multiplied by 3, but this maneuver is quite risky. The unit must make a Piloting Skill Roll as described above for both the MASC and the supercharger.

### EVADING (MOVEMENT MODE)

Evading enables a unit to avoid enemy attacks.

A unit's Evading MP equals its Running/Flanking MP, and any attack against an Evading unit suffers a +1 to-hit modifier, in addi-



tion to its normal movement modifier and any other applicable modifiers. An Evading unit generates 2 Heat Points per turn, in addition to the standard 2 Heat Points for running, and may not make any attack during the turn it used Evading movement.

To use Evading movement, a 'Mech must have two working hip actuators. Also, a prone 'Mech receives no benefit from Evading movement, even if it started the Movement Phase using Evading movement. For example, if an Evading 'Mech fails a Piloting Skill Roll during the Movement Phase of a turn, it does not receive the +1 to-hit modifier during the Weapon Attack and Physical Attack phases of that turn.

A 'Mech may not engage either MASC or a supercharger when using the evading movement mode.

### Skilled Evading

Under the Skilled Evading option, the to-hit modifier gained from Evading movement is based on the MechWarrior's Piloting Skill, as shown in the Skilled Evading Table.

SKILLED EVADING TABLE	
Piloting Skill	To-Hit Modifier for Evading
6 or greater	+0
4-5	+1
2-3	+2
0-1	+3

### SHIELDING (MOVEMENT MODE)

A shielding unit uses movement to put itself in harm's way to protect another target (another unit, a building, a hex and so on) from attacks.

A shielding unit may only expend its current Walking/Cruising MP, but it is considered to have run/flanked for purposes of the attacker movement modifier during the turn in which it is shielding (it can make all standard weapon and physical attacks during that turn). After its movement is finished, it must designate an adjacent hex to receive its protection (that hex can be its own hex, provided the stacking rules allow such movement; i.e. it is shielding a unit in its own hex). During the Weapon Attack Phase of the turn when the unit used the Shielding movement mode, all attacks against the designated hex (whether against the hex itself, or against units or a building in the hex, and so on) that pass through the hex occupied by the shielding unit add a modifier based on the Shielding Table.

SHIELDING TABLE	
Unit Type	Modifier
Vehicle	+1
'Mech, ProtoMech or Mechanized Infantry*	+2
Large Vehicle**	+3

\*See below.  
\*\*Combat or Support Vehicle. Rail and Large Naval Vessel Support Vehicles cannot use the Shielding movement mode.

These modifiers are cumulative, so that two shielding vehicles in a hex would provide a +2 modifier, a shielding vehicle and a 'Mech would provide a +3 modifier and two shielding ProtoMechs would provide a +4 modifier.

The shielding unit must equal the height of the unit or building it is protecting. For example, a Small- or Medium-sized vehicle can only protect a unit of Level 1 height (or the first level of a building); it cannot protect a 'Mech, as the 'Mech is Level 2 height (though a Large Vehicle, which is considered 2 levels high, can shield a 'Mech; see Unit Heights Table, p. 99, TW). A Level 1 vehicle or a ProtoMech can only shield a 'Mech if the 'Mech is prone. A 'Mech can shield any other unit, but can only shield the first 2 levels of a building; players may wish to use the expanded Line of Sight and Dead Zone rules to determine these situations (see p. 79).

If an attack against a shielded target misses, compare the Margin of Failure against the modifier of any unit shielding, as shown on the Shielding Table. If the MoF is equal to or less than that modifier, the attack automatically strikes the shielding unit; determine direction of attack and location for applying damage normally. If two units equally apply, randomly determine which unit is struck. If the MoF is greater than the modifier of any of the shielding units, then the attack misses completely (if using the Missed Shots rule, the controlling player determines where the attack struck, and so it cannot strike either the shielding unit(s) or the original target; see *Missed Shots*, p. 81). For example, a 'Mech and a vehicle are shielding another vehicle, resulting in a final modified To-Hit Number of 9 to strike the vehicle they are shielding (a total applied modifier of +3). The die roll result is an 8, giving an MoF of 1. Because that is equal to or less than the modifiers on the Shielding Table for both the 'Mech (a +2 modifier) and the shielding vehicle (a +1 modifier), the controlling player of the attacking unit randomly determines whether the shielding 'Mech or the shielding vehicle is automatically struck by the attack that missed its intended target. If the MoF was 2, only the 'Mech could potentially be struck by the missed shot.

**Glancing/Direct Blows:** If a shielding unit is struck by an attack intended for the target it was shielding, the Glancing/Direct Blows rules (see p. 80) are never used when applying damage.

**Four-Legged 'Mech:** If a 'Mech is hull-down (see *Hull Down*, p. 21), then a unit at Level 1 height can shield it.

**Infantry:** Mechanized infantry is the only infantry type that can use the Shielding movement mode; apply a +2 modifier to all weapon attacks made by a mechanized infantry unit in the turn it is shielding. If using the Squad Deployment rules (see p. 27), a mechanized infantry squad cannot use the Shielding movement mode.

**ProtoMechs:** If a shielding ProtoMech is struck by an attack intended for the target it was shielding, use the Special ProtoMech Hit Location Table (see p. 184, TW).

**Rail and Large Naval Vessel Support Vehicles:** Rail and Large Naval Vessel Support Vehicles cannot use the Shielding movement mode.

**VTOL Vehicles:** A grounded VTOL Vehicle cannot use the Shielding movement mode. However, an airborne VTOL Vehicle—provided its bottom elevation is at the same level as the underlying terrain of the hex it is shielding and the unit/hex it is shielding is not of a greater height than the VTOL Vehicle—can use the Shielding movement mode.

INTRODUCTION

ADVANCED  
GROUND MOVEMENT

ADVANCED  
COMBAT

ADVANCED  
BUILDINGS

ADVANCED  
SUPPORT  
VEHICLES

GENERAL  
RULES

ADVANCED  
SUPPORT VEHICLE  
CONSTRUCTION

ADVANCED  
WEAPONS  
AND EQUIPMENT

INDEX

RECORD SHEETS



For example, a standard VTOL Vehicle could not shield a 'Mech, but a Super-Heavy VTOL Vehicle, which is considered 2 levels tall (see *Super-Heavy Vehicles*, p. 378), could shield a 'Mech, provided it was still airborne and covered the 'Mech, as described.

**Air-to-Ground Attacks:** Shielding cannot be used against any type of air-to-ground attacks.

**Area-Effect Weapons:** A shielding unit has no effect on the damage applied by an area-effect weapon, though the shielding modifier is still applied for the attempt to target a hex, such as from artillery.

**Swarm Ammo:** Swarm ammo can not target a unit (or building level) being protected by a shielding unit; such protected units are susceptible to Swarm's normal secondary attack mechanic, however.

**Targeting a Shielded Hex:** A unit attempting to target a hex with an attack must still apply the shielding modifier. For example attempting to lay a weapon-delivered minefield.

### PHYSICAL DEFENSE (MOVEMENT MODE)

A 'Mech enacting the Physical Defense movement mode leaves itself wide open to weapon attacks in the hopes of catching the unwary opponent in a trap that it springs in order to bring a physical attack to bear.

The controlling player, during the Movement Phase of a turn, must announce that a unit is enacting the Physical Defense movement mode. A unit using this movement mode cannot expend any MP during the Movement Phase of that turn, nor can it make any weapon attacks during the turn's Weapon Attack Phase. During the Physical Attack Phase, when the controlling player nominates the 'Mech, the 'Mech may expend its current Walking MP and may then make a physical attack; it is considered to have walked for purposes of the attacker movement modifier during the turn in which it is using the Physical Defense movement mode. The unit can make all standard physical attacks except charging or death from above during that turn, provided the criteria for such attacks are met.

**Charging and DFA:** A target in Physical Defense movement mode cannot be the target of a charging or DFA Physical Attack.



CPLT-K4 Catapult, *Devil's Brigade*

### CRAWLING (MOVEMENT MODE)

A 'Mech must have two hands, two lower arm, two upper arm and two shoulder actuators functioning to attempt crawling.

A 'Mech that begins a Movement Phase prone can select the Crawling movement mode. The unit can only expend half its current Walking MP (round down); all standard costs to enter a new hex apply. Additionally, to enter a new hex, the controlling player must make a standard Piloting Skill Roll (i.e. all damage modifiers apply), applying the appropriate modifiers from the Weight Class Physical Attack Modifiers Table (see p. 88). A successful roll means the unit can enter the hex. A failure does not cause any damage or result in a fall; the unit simply cannot enter the hex, and the MP expended to do so are lost. The player can make any number of Piloting Skill Rolls to enter a hex, provided it has MP remaining to do so. A unit cannot attempt to stand in the same turn in which it is using the Crawling movement mode.

A unit can expend the standard 1 MP to change facing in a hex while crawling without the need for a Piloting Skill Roll.

A unit that has crawled is considered to have walked for purposes of the attacker Movement Modifier and can make any weapon and physical attacks, as appropriate for a prone 'Mech, during that turn.

**Destroyed Gyro:** A 'Mech with a destroyed gyro cannot crawl.

### HURRIED MOVEMENT

In standard rules, the movement costs for various terrain (woods, levels and so on), even when running and/or sprinting, reflect a "studied" movement in order to avoid a fall. In some terrain, such as water, rubble and so on, the potential for a fall exists regardless of such studied movement.

In advanced rules, a 'Mech can engage in hurried movement, trading speed for a chance at falling that would not exist under standard rules. Whenever a unit enters a hex that requires an expenditure of movement beyond the 1 MP to enter, the player may choose to ignore one, some or all of those additional MP (the 1 MP for entering a hex can never be ignored). If any 1 MP is ignored, the controlling player makes an automatic standard Piloting Skill Roll with an additional +2 modifier upon entering the hex to avoid falling. Each additional MP ignored applies a cumulative +2 modifier, though only a single Piloting Skill Roll per hex is made. Finally, apply the modifiers from the Weight Class Physical Attack Modifiers Table (see p. 88) to the Piloting Skill Roll, as appropriate for the 'Mech's weight class. If the Piloting Skill Roll fails, the 'Mech falls in the hex it entered, taking standard falling damage; even if the 'Mech just changed levels downward, those levels are not taken into consideration for determining levels fallen. It can continue to move, however, provided it has sufficient MP to stand, move out of the hex and so on.

Hurried movement can be used in multiple hexes in a turn, with the controlling player choosing to ignore various MP requirements in a given hex, making appropriate Piloting Skill Rolls as noted above immediately upon entering each hex.

A player may never ignore the movement cost for changing a level upward, nor any terrain costs that automatically cause a Piloting Skill Roll, such as buildings, water, rubble and so on.

**Vehicles and ProtoMechs:** Vehicles and ProtoMechs can also use hurried movement. If a vehicle fails its Driving Skill Roll, automatically roll once on the Motive System Damage Table. For ProtoMechs, use the Gunnery Skill Rating to make the appropriate Piloting Skill Roll. A failure results in 1 point of damage applied to all locations.



INTRODUCTION

ADVANCED GROUND MOVEMENT

ADVANCED COMBAT

ADVANCED BUILDINGS

ADVANCED SUPPORT VEHICLES

GENERAL RULES

ADVANCED SUPPORT VEHICLE CONSTRUCTION

ADVANCED WEAPONS AND EQUIPMENT

INDEX

RECORD SHEETS



**Terrain Piloting Skill Roll Modifiers:** If a 'Mech using hurried movement enters terrain that applies a modifier to any Piloting Skill Rolls, those modifiers must be added to the hurried movement PSR. If a 'Mech enters terrain using hurried movement that automatically requires a Piloting Skill Roll, the player must make two Piloting Skill Rolls (one for the terrain and one for the hurried movement), applying all appropriate modifiers to both PSRs.

**Terrain Factor:** If the Terrain Factor rules are in use (see p. 64) a failed Piloting Skill Roll will result in damage to the terrain in the hex. Damage for a 'Mech's failed PSR is the standard falling damage applied to the hex. For vehicles, divide the unit's weight by 10, rounding up. For ProtoMechs, apply a single point of damage.

**Water:** Hurried movement cannot be used in a water hex to avoid the penalties for moving in water.

*In the Movement Basics Diagram (see p. 51, TW), the 'Mech in Hex A cannot enter Hex D, as it has a Walking MP of 5 and would require 7 MP to enter Hex D. However, using hurried movement, the controlling player of the 'Mech could choose to ignore the 2 MP requirement to enter the heavy woods in the hex, applying a +4 modifier (+2 for each 1 MP ignored) to an immediate Piloting Skill Roll upon entering Hex D; the controlling player could not ignore the MP required for entering the hex or for changing 1 level upward. If the unit was a medium or light 'Mech, it would apply a -1 or -2 modifier respectively to that Piloting Skill Roll, respectively, from the Weight Class Physical Attack Modifiers Table. If the Piloting Skill Roll fails, the 'Mech falls in Hex D.*

## HULL DOWN

A four-legged 'Mech can choose to go hull-down by squatting behind an obstacle so that only its weapons are visible to the enemy. Though the 'Mech can do this in any hex, the maneuver will only help the 'Mech if it has partial cover from its opponent without going hull-down.

Going hull-down or leaving a hull-down position costs 2 MP. Attacks against a hull-down, four-legged 'Mech are resolved normally unless the 'Mech has partial cover. If partial cover exists between the attacker and the four-legged 'Mech, the attack receives a +2 modifier in addition to the standard partial-cover modifier; as usual, attacks that strike the legs will strike the terrain instead.

**Bipedal 'Mech:** A bipedal (two-legged) 'Mech can go hull-down exactly as described above by "taking a knee"; that is, it has one knee down on the ground, the other leg bracing for support. All the rules above apply to a bipedal 'Mech "taking a knee" to go hull-down, except that to leave a hull-down position, in addition to the 2 MP expenditure, the bipedal 'Mech must make a standard Piloting Skill Roll. A failure does not result in a fall; instead, the 'Mech simply did not stand up and the MP are expended (the 'Mech can continue to attempt to stand up as long as it has MP available).

A hull-down 'Mech can punch units in the same hex; punches against a 'Mech are resolved using the Kick Location Table.

**Prone:** A 'Mech can move from hull-down to a prone position without any MP expenditure. To move from a prone position to a hull-down position requires the expenditure of 1 MP (+1 additional MP for each missing and/or destroyed

actuator), but does not require a Piloting Skill Roll. A 'Mech can move from a prone position, to a hull-down position, to a standing position (or vice versa) all in the same Movement Phase, provided the unit has available MP (and makes the appropriate standard Piloting Skill Rolls as necessary).

**Leg-Mounted Weapons:** Leg-mounted weapons cannot be fired when a unit has gone "hull down."

**Leg Destruction:** If a 'Mech (either four-legged or bipedal) has a destroyed leg, it cannot go hull down.

## Hull Down Vehicles

Vehicles are too low to the ground to take advantage of partial cover. However, there may be shorter terrain not marked on the standard mapsheets that can allow vehicles to go hull-down.

Such terrain can be assigned as part of the scenario setup, with the players determining the terrain's location (see *Half Levels*, p. 31). Additionally, the terrain created by standard infantry "digging in" (see *Digging In*, p. 108), or specialized infantry creating a fieldwork (see *Trench/Fieldwork Engineer*, p. 341), can also be used by a vehicle to go hull-down.

A vehicle can go hull-down in three situations (note that in all situations the standard Hit Location Tables are used, except as noted below).

First, if a vehicle (including a landing VTOL/WiGE) enters a half-level hex, it can go hull-down by spending 2 MP. Attacks that would strike the vehicle's Front side add a +2 modifier. In addition, if the attacks hit, they will strike the turret if the vehicle has one, or the front armor if it does not. Attacks from other directions are resolved normally.

Second, if a vehicle is adjacent to a half-level hex and the LOS of the attack passes through that hex, the vehicle is considered hull-down for that attack.

Finally, if a vehicle (including a landing VTOL/WiGE) enters a hex "built" by an infantry unit (either friendly or enemy), as noted above, all the rules for a half-level hex apply, except that attacks against both the Front and Side receive a +2 modifier; only attacks against the Rear are treated normally. If an attack strikes the side of a unit without a turret, it will hit the appropriate side.

While the vehicle is hull-down, none of its front-mounted weapons may fire (or weapons in the location oriented toward a half-level hex, in the case of an adjacent half-level hex), though the turret may fire to the front (or in the direction of the adjacent half-level hex) as usual.

**Large Vehicles:** Large Vehicles cannot use half-level hexes or infantry-built hexes for cover. However, if a Large Vehicle is adjacent to a Level 1 hex and the LOS of the attack passes through that hex, the vehicle is considered hull-down for that attack.

**Motive System Damage Table:** Attacks that receive a +2 modifier for a vehicle being hull down ignore any chance for a roll on the Motive System Damage Table.

**Backward Movement:** Note that the above situations assume the vehicle entered the hex using front movement. If the vehicle entered a hex using backward movement, then simply reverse the locations (i.e. front armor becomes rear armor and so on). In the first and second cases above, the unit can change facing in the hex, as desired; again change the armor location for any attacks that strike the target, as appropriate. However, in the final case, when a vehicle enters an infantry "built" hex, it cannot change facing in the hex, but must first exit the hex, then change facing, and then re-enter the hex once more.

## BACKWARD MOVEMENT (EXPANDED)

This rule allows units to change levels while moving backward.

Under this option, a backward-moving unit can change 1 level per hex. The controlling player must make a successful Piloting/Driving Skill Roll each time the unit crosses a level line. 'Mechs may not change levels by more than 1 while moving backward.

If the roll fails for a 'Mech, that 'Mech falls into the hex it was moving into or out of, whichever is lower; the change in levels is not taken into consideration for determining the levels fallen.

If a vehicle's Driving Skill Roll fails, the vehicle fails to cross the level line. It stays in its current hex and must spend 1 additional MP (if it doesn't have that MP to spend, its movement is ended). The controlling player can continue to make Driving Skill Rolls to attempt the level change, but he must pay 1 extra MP each time the roll fails.

## CLIMBING AND LEAPING

The optional Climbing and Leaping rules allow BattleMechs without jump jets to climb, leap or drop multiple levels.

### Climbing

The Climbing rules enable a 'Mech to enter a hex that is 3 or more levels higher or lower than the hex it occupies.

To attempt a climb, a 'Mech must have at least one arm with all four actuators (hand, lower arm, upper arm and shoulder) functional, and that arm's hand must be free (not holding a physical attack weapon such as a sword, hatchet and so on, a hand-held weapon or other object).

Only Walking MP can be used when climbing—running units cannot climb. Each level changed in a climb costs 2 MP if the 'Mech has two undamaged hands, or 3 MP if the 'Mech has only one hand.

For each level climbed, the 'Mech's controlling player must make a Piloting Skill Roll. Apply a +2 modifier, in addition to the standard +1, if the 'Mech has only one undamaged hand. If the roll fails, the 'Mech falls from a height equal to the last level it successfully reached.

In certain cases, a unit may attempt to climb a cliff (or building) so high that the climb requires several turns. In such cases, move the 'Mech into the lower of the two hexes at the end of each turn, turn it so that it faces the higher hex and note the 'Mech's levels (the two levels it occupies). The unit may continue its climb in the following turn or remain clinging to the cliff face.

While in the middle of a climb, a 'Mech may fire only rear-mounted weapons; the unit cannot perform physical attacks. Apply a +1 modifier to any Piloting Skill Rolls the unit must make while climbing. If the unit has only one undamaged hand actuator, apply a +2 modifier. (These modifiers are added to any other applicable modifiers.)

When determining line of sight for a climbing unit, treat the 'Mech as if it were standing in the hex it occupies at its current climbing level, rather than the level of the hex. Climbing 'Mechs make relatively easy targets, so any attack against such units receives a -2 to-hit modifier.

**Actuator Damage:** A 'Mech must have an arm with all four actuators functional to climb. If the hand actuator being used to climb is destroyed, the 'Mech will automatically fall; if the 'Mech is using two hands, then the 'Mech will only fall if both hand actuators are destroyed. If any other actuator is destroyed the 'Mech does not automatically fall, but it cannot continue to climb either up or down; it can only use the leaping rules below to get off of the cliff face.

**Buildings:** A unit climbing a building hex is considered to have entered that building hex as far as the Construction Factor of the hex is concerned. If the weight of the unit exceeds the Construction Factor of the hex—whether that occurs when the unit starts the climb, or during the climb (for example, if the building hex takes damage)—the hex collapses exactly as if the unit had entered that hex; treat the unit as occupying that building hex at the level it was climbing at the time it collapsed (see p. 176, *TW*).

**Planetary Conditions:** Any planetary conditions that apply a Piloting Skill Roll modifier based on terrain conditions, such as snow or rain or wind, must be added to all Piloting Skill Rolls (visibility modifiers do not apply).

### Leaping

The Leaping rules enable 'Mechs to leap down more than 2 levels, at considerable risk of leg damage and falling.

Any leap down that covers more than 2 levels costs 4 MP, regardless of the number of levels leaped and of the terrain in the ending hex (though the target hex must be a hex the 'Mech can legally enter). Any leaping 'Mech must also make two Piloting Skill Rolls: one to avoid leg damage and one to avoid falling. If both Piloting Skill Rolls succeed, the 'Mech may continue to move normally.

The first roll receives a modifier equal to the number of levels in the leap multiplied by 2. If the roll fails, each of the 'Mech's legs takes damage equal to the number of levels the unit leaped. The controlling player must roll once on the Determining Critical Hits Table for each leg. The player must roll twice if a leg's internal structure is damaged in the leap.

Add a modifier to the second Piloting Skill Roll equal to the number of levels the 'Mech leaped. If this roll fails, the 'Mech falls the number of levels it attempted to leap and lands in the lower hex. Determine falling damage per standard rules.

A 'Mech may suffer leg damage and falling damage if it fails both rolls.

### Dangle-and-Drop

The "dangle-and-drop" maneuver is a safer but slower way of dropping down multiple levels.

To use the dangle-and-drop procedure, a 'Mech must have two undamaged hand actuators. The 'Mech must start its turn in the hex where it will "dangle-and-drop" and spends the entire Movement Phase crawling down, dangling from the cliff by its hands. (This places its legs 2 levels closer to the ground than they would be if it leaped down.) Move the 'Mech into the lower hex and turn it so that it faces the higher hex; calculate its levels as if it were standing in a hex 2 levels lower than the higher hex. For the remainder of the turn, treat it as if it were in the middle of a climb (see *Climbing*, at left).

In the following Movement Phase, the 'Mech may either continue to dangle, or drop to the ground at a cost of 4 MP, or start to climb down. As with leaping, if the 'Mech drops, the controlling player must make two Piloting Skill Rolls to avoid leg damage and falling. When determining the Piloting Skill Roll modifiers and damage, reduce by 2 the number of levels traveled.

## STACKING (EXPANDED)

In standard rules play, if a unit enters a hex occupied by an enemy unit (with the exception of a 'Mech entering a hex occupied by an enemy infantry unit) it cannot then exit the hex in the same Movement Phase. In this expanded stacking rule, an opposing unit



can enter and then exit a hex occupied by an enemy unit if that enemy unit is immobile, abandoned or, in the case of a 'Mech, prone. All other stacking rules (see *Stacking*, p. 57, *TW*) still apply; i.e. if the unit would violate the stacking rules (for example a 'Mech entering the hex of a prone enemy 'Mech) it must have enough MPs to exit the hex, or it cannot enter the hex.

## SKIDDING

The following rules modify the Skidding rules found on pages 62-66 of *TW*. These optional modifications make for more realistic play, but they are a bit more complicated. Follow the standard rules for skidding unless specifically noted below.

Generally, a 'Mech running on road or pavement may make a single facing change at the end of its movement without risk of skidding. However, a unit may skid if it continues to move after making a facing change or makes two or more facing changes in a row.

To determine if a unit skids, first trace the path of the unit's entire intended movement and place a die or other marker in each hex where a potential skid may occur (i.e. the first hex entered after a facing change). Then count how many hexes the unit covers during its entire movement. Use this number to determine the modifier for the Piloting Skill Rolls made to avoid skidding (see the Skid Modifier Table, p. 63, *TW*). Use this modifier for all the required rolls. (Note that this differs from the standard skidding rules, under which each roll receives a modifier based on the hexes moved prior to the facing change.)

Next, the controlling player makes a Piloting Skill Roll with the appropriate skid modifier for each hex where a skid may occur, starting with the earliest possible hex in its movement. If all the Piloting Skill Rolls succeed, place the 'Mech in the ending hex of its intended movement.

If a Piloting Skill Roll fails, the 'Mech falls and skids. Place the 'Mech in the hex where the failed roll occurred. Place it with the appropriate facing, but do not move it or turn it according to the intended movement. Next, determine the length of the skid, which equals the remaining hexes in the intended move, divided by 2 and rounded down. If the result is 0 hexes, the unit simply falls in the hex it occupies and takes standard falling damage.

If the result is 1 or more hexes, the unit falls and then skids in the direction it was traveling before making the facing change that caused the skid. For each hex the 'Mech skids, it takes damage equal to its standard falling damage, divided by 2 and rounded up.

Regardless of the final result of the fall or skid, the unit's move ends and it may not spend any more MP in that Movement Phase.

## PILOTING SKILL ROLLS

Advanced players can use the following changes to standard Piloting Skill Roll modifiers to increase the realism of their game play. Note that with the exception of fumbles, these options apply to 'Mech units only.

### FUMBLES

Standard-rules play assumes that all things being equal, while warriors may stumble in piloting their 'Mechs or vehicles, they never do so in a catastrophic way. Real movement is much different, however, and despite years of training in keeping a 12-meter-tall metal giant on its feet (or that vehicle moving at the right angle), circumstances arise where even the elite can stumble and fall.

Whenever a player makes a Piloting/Driving Skill Roll with a result of 2, a fumble has occurred and the result is always a failure, regardless of whether the modified Target Number was 2 or less.

### TAKING DAMAGE

Any time a 'Mech takes 20 or more Damage Points in a single phase, its controlling player must make a Piloting Skill Roll to keep the 'Mech from falling. The roll receives a modifier based on the number of Damage Points taken during the phase and the 'Mech's weight class, as noted in the Taking Damage Weight Class PSR Modifiers Table. For every 20 Damage Points a unit takes, it receives a +1 modifier. For example, a unit that takes 40 to 59 Damage Points receives a +2 modifier, a unit that takes 60 to 79 Damage Points receives a +3 modifier, and so on.

**Weight Class Physical Attack Modifiers:** Note that the Taking Damage Weight Class PSR Modifiers are different than the Weight Class Physical Attack Modifiers (see p. 88); the latter applies to modifiers added to physical attack die rolls, while the former applies to modifiers added to the Piloting Skill Roll to avoid falling after taking damage (i.e. for taking more than 20 points of damage, for being kicked and so on).

*A 50-ton medium 'Mech with TSM (running hot) and a Piloting Skill of 5, after running in the turn, is making a kicking attack against an assault 'Mech that moved 5 hexes. The modified To-Hit Number is 6 [5 (Piloting Skill Rating) -2 (Kicking modifier) -1 (Medium weight class modifier from the Weight Class Physical Attack Modifiers Table) +2 (attacker movement modifier) +2 (target movement modifier) = 6]. The roll is a success, and after determining the location, 20 points of damage is applied to the assault 'Mech's right leg. The Piloting Skill of the assault 'Mech is 5 as well, leaving that unit's player to make two Piloting Skill Rolls (one for taking 20 points of damage and one for being kicked) against a modified Target Number of 4 [5 (Piloting Skill Rating) + 1 (20 points of damage), -2 (Assault weight class modifier from the Taking Damage Weight Class PSR Modifiers Table) = 4].*

### TAKING DAMAGE WEIGHT CLASS PSR MODIFIERS TABLE

Weight Class	Modifier
Light (Ultra-Light)	+1
Medium	+0
Heavy	-1
Assault	-2

INTRODUCTION

ADVANCED GROUND MOVEMENT

ADVANCED COMBAT

ADVANCED BUILDINGS

ADVANCED SUPPORT VEHICLES

GENERAL RULES

ADVANCED SUPPORT VEHICLE CONSTRUCTION

ADVANCED WEAPONS AND EQUIPMENT

INDEX

RECORD SHEETS



## LEG DAMAGE

Under standard rules, a hip actuator critical hit causes a 'Mech's leg to freeze, adds a +2 Piloting Skill Roll modifier and reduces the 'Mech's MP by half, regardless of previous critical damage to the leg. This rule is designed to limit damage-related modifiers so that excessive leg damage does not completely cripple a 'Mech.

As an option, players can use the "crunchy broken leg" rule for leg damage. Under the crunchy-broken-leg rule, each hip actuator critical hit adds a +2 Piloting Skill modifier for rolls and reduces the 'Mech's MP by 2. However, these effects are cumulative—they are added to modifiers produced by any other leg damage the unit has already taken or receives in subsequent turns.

## FALLING (EXPANDED)

In standard rules, when a 'Mech fails a Piloting Skill Roll to avoid falling, it automatically falls; nothing can be done to avoid that fate. However, in advanced rules, a fall may not exactly be a fall.

When a 'Mech fails a Piloting Skill Roll to avoid falling, compare the Margin of Failure (MoF) to the Piloting Skill Rating MoF Falling Table. If the roll result is within that MoF, the 'Mech does not fall, but instead goes hull-down (see *Hull Down*, p. 21). If the MoF is greater than that noted on the table, the 'Mech falls per standard rules. For example, a 'Mech with a Green Piloting Skill Rating is rolling against a modified Target Number of 6. Looking at the Piloting Skill Rating MoF Falling Table, the MoF that a Green pilot can have is 0, so just as in standard rules, the controlling player must roll 6 or higher to avoid falling. If the pilot was Regular or Veteran, the controlling player could roll a 5 (MoF of 1), while an Elite pilot could roll a 4 or 5 (MoF of 2); in all three cases, the 'Mech would simply go hull-down without falling.

## ATTEMPTING TO STAND

When a 'Mech attempts to stand from a prone position, it uses its arms and legs to lift itself up. Therefore, missing or damaged arm actuators make standing up more difficult.

Players can simulate this condition by applying additional modifiers to the Piloting Skill Roll needed to stand a 'Mech up. Apply a +1 modifier for each arm that has actuator damage or is missing actuators. Apply a +2 modifier per arm if the arm is destroyed or missing. All other appropriate Piloting Skill modifiers apply as well.

Multiple damaged or missing actuators in the same arm do not produce cumulative modifiers; the maximum modifier for a damaged or destroyed arm is +2.

## Careful Stand

If a 'Mech takes its time, it can improve its chances of standing up successfully. Rather than simply spending 2 MP, a 'Mech can spend its entire Movement Phase standing up (i.e. only one careful standing attempt can be made per turn). In this case, the unit is

considered to have walked. If the 'Mech had more than 2 Walking MP available, the Piloting Skill Roll target is modified by -2. No modifier applies if the unit had only 1 or 2 Walking MP available.

# VEHICLES

The following additional rules apply to vehicle movement.

## MOVEMENT

Vehicles must move across the battlefield without the benefit of neurohelmets or the sophisticated gyros used by 'Mechs. With most vehicles, the driver can only use the controls to accelerate, brake and steer. Consequently, skillful maneuvering in rough terrain can prove very difficult.

The complexity of advanced-rules play restricts the movement of vehicles more than the standard Level 2 rules, but offers vehicle drivers a few special maneuvers and other advantages to make up for reduced mobility.

## Lance Movement

'Mechs tend to operate as independent units on the battlefield. Conventional vehicles operate in lances of several units that work closely together to achieve an objective.

Under advanced rules, all vehicles must be organized into lances of four vehicles each. If necessary, remaining vehicles may be organized into a single short lance of one, two or three units. During the Movement Phase of the turn, players alternate moving their units according to the standard rules, with each vehicle lance moving as a single unit. All vehicles in a lance move during a turn at the same time, regardless of casualties. For example, if a lance starts the game with four Bulldog tanks and three of those tanks are lost in combat, moving the last surviving tank constitutes moving the lance.

**Unusual Unit Types:** Some armies organize their units into formations other than lances of four. For example, the Clans use units of ten, called Stars. The Com Guards organize in Level II units that contain six vehicles. A player must organize his vehicles into units appropriate to the force he is playing, whether Clan, ComStar or Inner Sphere.

## Speed

A 'Mech's humanoid structure gives it excellent acceleration and deceleration capability. Vehicles operate under certain speed restrictions due to their construction.

**Acceleration and Deceleration:** Unlike 'Mechs, vehicles cannot achieve maximum velocity in 10 seconds. Instead, vehicles can only increase one category of speed per turn. For example, if a vehicle stands still in one turn, it can move no faster than Cruising speed in the next turn. In the turn after that, it can move at Flanking speed. Make a note of the movement type used in each turn (Standing, Cruising or Flanking) on each unit's record sheet.

**Gunning It:** A unit can "gun it," however, dangerously pouring on speed. Doing so allows a player to go from standing still to Flanking speed, or from Cruising to Overdrive speed (see p. 25) in a single turn. Doing so requires the player to make a standard Driving Skill Roll before the vehicle moves. A failure results in an automatic roll on the Failed Maneuver Table (see p. 26), with the controlling player randomly determining, if necessary, the direction of the hexside change.

Units can decelerate to any speed in a single turn.

## PILOTING SKILL RATING MOF FALLING TABLE

Piloting Skill Rating	Margin of Failure
6-7	0
2-5	1
0-1	2



**Declaring Speed:** Before moving each unit, the player controlling a vehicle must announce how many MP the vehicle will expend. The vehicle must then spend these Movement Points during the Movement Phase, even if this forces the vehicle to hit an obstacle or make a dangerously tight turn.

In a friendly game, the player can count hexes carefully to plan out each vehicle's movement. For more realistic play, the player should announce the MP without examining the board too closely. After all, the vehicle's driver must simply step on the gas or brake and handle obstacles as they come!

**Reverse Gear:** Except for VTOLs, vehicles may not combine forward and backward movement in the same turn.

### Turn Modes

Vehicles are not nearly as agile as 'Mechs. Anyone who has driven a car knows that the tightness of a turn is limited by the speed of the vehicle; the faster you are going, the more gradual the turn must be in order to keep from skidding, fish-tailing or even rolling over.

This reality is represented in *BattleTech* play by the turn mode: the number of hexes forward (or backward, if the vehicle is moving in reverse) the unit must move in a straight line before it can safely make a single hexside facing change. Slippery terrain increases the turn mode, as shown on the Turn Mode Table.

A vehicle can attempt to make a facing change without moving the required distance forward. The controlling player must make a Driving Skill Roll, with a modifier equal to the required turn mode minus the number of hexes actually moved. For example, a Hover Vehicle expending 15 MP that attempts to turn after moving only 1 hex forward would make the Driving Skill Roll with a +2 modifier, because the craft's turn mode is 3 (3 - 1 = 2); if the vehicle were a light weight class, however, the modifier would only be a +1, as a light vehicle receives a -1 modifier. If this roll fails, the vehicle suffers the appropriate effect indicated on the Failed Maneuver Table. To find the exact effect, roll 2D6 and add the Margin of Failure from the Driving Skill Roll to the result. Then add a vehicle-type modifier, as shown on the table. The total result indicates what happens to the vehicle.

Hexes moved before a failed Driving Skill Roll for tight turns or other maneuvering no longer apply to the turn mode. For example, a unit expending 10 MP has a Turn Mode of 2. After moving 1 hex forward, it attempts a turn but fails the Driving Skill Roll. It must now move 2 hexes forward rather than 1 to make a safe turn; the 1 hex it moved before the failed roll no longer counts toward the 2-hex turn mode.

### Advanced Maneuvers

Vehicles have a few advantages over 'Mechs when it comes to maneuverability. The ability to perform sideslip and bootlegger reverse maneuvers can help a vehicle quickly escape or bring its weapons to bear.

**Sideslip:** VTOLs and Hover Vehicles can make a controlled sideslip. The sideslip is executed just like a four-legged 'Mech's lateral shift (see p. 50, *TW*). However, any time a vehicle makes a sideslip, the controlling player must make a Driving Skill Roll with a -1 modifier. If the roll fails, the vehicle slips too far, moving an extra hex in the direction of the sideslip. If the vehicle has MP left, the extra hex costs MP as normal. However,

## TURN MODE TABLE

MP Expended	Turn Mode
1-4	0
5-9	1
10-14	2
15-19	3
Every 5 above 19	+1
Light Vehicle	-1
Medium/Heavy Vehicles	+0
Assault Vehicle	+1
Mud, Sleet, Heavy Fog or Heavy Rainfall	+1*†
Ice, Heavy Snowfall	+2*‡

\*Does not apply to Hover, VTOL or WiGE Vehicles.

†Does not apply to tracked vehicles

‡Only apply a +1 to tracked vehicles

the vehicle moves the extra hex even if it has no more MP, in which case this move ends the vehicle's movement.

A sideslip is not a turn, and can be executed regardless of turn mode. Furthermore, a sideslip counts as a hex of forward movement for meeting the requirements of the turn mode.

**Bootlegger:** All vehicles except Tracked Vehicles, WiGEs and Naval Vessels may attempt to make a quick 180-degree turn known as a bootlegger. If successful, this move turns the vehicle three hexsides and brings it to a complete stop. Because the vehicle stays in the same hex, it need not meet turn-mode requirements.

In order to gain the momentum needed to attempt a bootlegger, a vehicle must have moved at least three hexes in a straight line since its last facing change. The controlling player then announces his intention to bootlegger and spends 2 MP. He makes a Driving Skill Roll with a modifier equal to the vehicle's current turn mode +2. If the roll succeeds, the vehicle turns to face the opposite direction and ends its movement. If the roll fails, the player rolls once on the Failed Maneuver Table as though his vehicle had just attempted a 1-hexside turn. Add a +2 modifier to the failed maneuver roll result.

Vehicles also can make bootleggers while moving backward.

**Overdrive:** A vehicle can attempt Overdrive speed, which is identical to the rules for Sprinting for a 'Mech (see *Sprinting*, p. 18). All those rules apply, except a failed Driving Skill Roll results in an automatic roll on the Failed Maneuver Table (see p. 26), applying +2 to the die roll result, with the controlling player randomly determining, if necessary, the direction of the hexside change. If a player is combining Gunning It (see p. 24) with Overdrive, the player must make two Driving Skill Roll modifiers to avoid rolling on the Failed Maneuver Table.

**Bonus MP (WiGE):** A WiGE Vehicle may receive a movement bonus of 1 additional MP for every three consecutive hexes it enters that have a lower level than the previous consecutive hex the WiGE Vehicle occupied. A WiGE vehicle can receive more than 1 additional MP in a given turn; the three-hex movement groups to receive such additional MP need not be consecutive.

INTRODUCTION

ADVANCED  
GROUND MOVEMENT

ADVANCED  
COMBAT

ADVANCED  
BUILDINGS

ADVANCED  
SUPPORT  
VEHICLES

GENERAL  
RULES

ADVANCED  
SUPPORT VEHICLE  
CONSTRUCTION

ADVANCED  
WEAPONS  
AND EQUIPMENT

INDEX

RECORD SHEETS



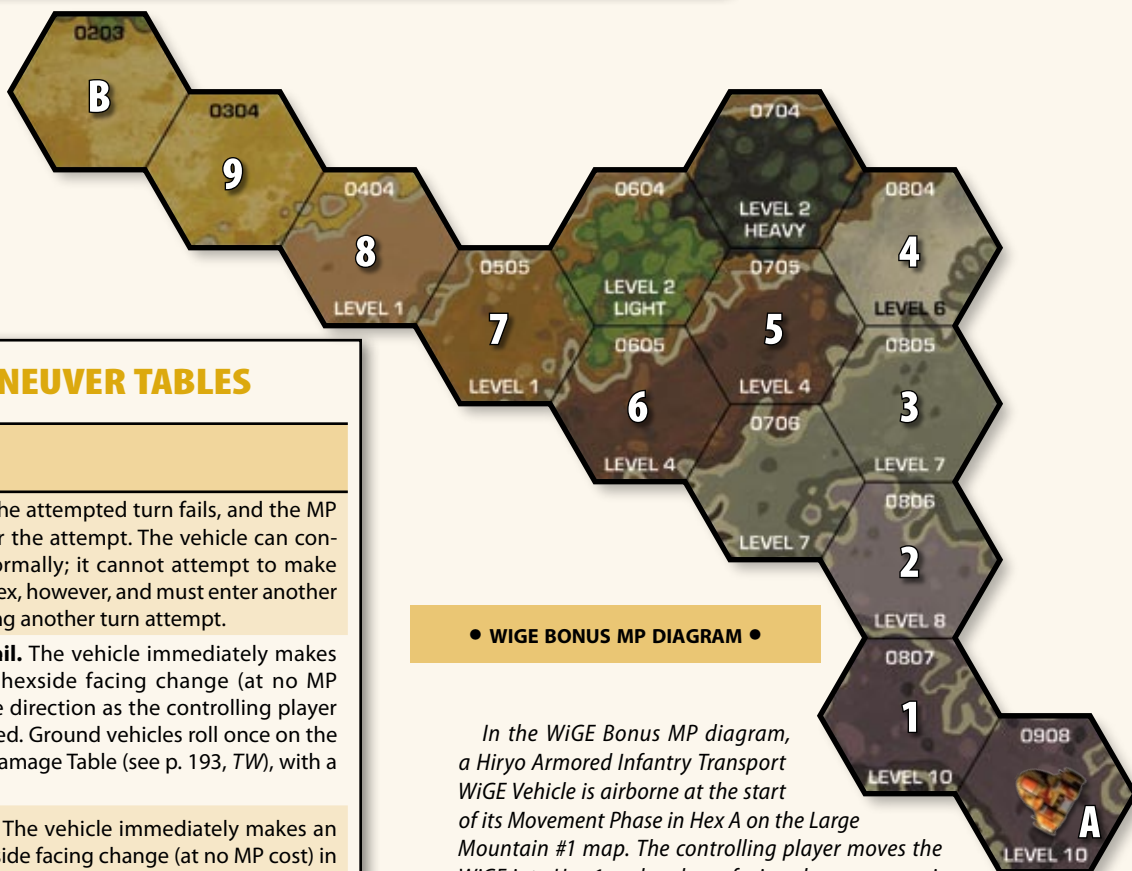

• WIGE BONUS MP DIAGRAM •

In the WIGE Bonus MP diagram, a Hiryo Armored Infantry Transport WIGE Vehicle is airborne at the start of its Movement Phase in Hex A on the Large Mountain #1 map. The controlling player moves the WIGE into Hex 1 and makes a facing change, preparing to enter Hex 2; the player will need to make a Driving Skill Roll to avoid sideslipping. The player then enters hexes 2, 3 and 4, expending a single MP for each hex. Because the Hiryo entered three consecutive hexes, each with a level lower than the previous hex, the Hiryo automatically gained 1 additional MP beyond its normal MP to expend this turn. The controlling player then makes two facing changes preparing to enter Hex 5; once more, the player will need to make a Driving Skill Roll to avoid a sideslip. The controlling player then moves the WIGE Vehicle into hexes 5 and 6, expending a single MP for each hex; hexes 4, 5 and 6 were not a consecutive group of three hexes with each hex a lower level than the next and so the WIGE Vehicle does not receive an additional 1 MP bonus. The player then moves the WIGE into hexes 7, 8 and the destination hex B, expending a single MP for each hex. As with hexes 1, 2 and 3, because the WIGE Vehicle entered three consecutive hexes, each with a level lower than the previous hex, the vehicle automatically gains 1 additional MP to expend, giving it a total of 2 additional MP to spend this turn (the player expended a total of 12 MP to move from Hex A to Hex B).

**Flipping Over**

If the result on the Failed Maneuver Table (at left) calls for a vehicle to flip over, determine the direction and distance of the skid as normal (see *Ground Vehicles*, p. 62, TW). Subtract 1 from the resulting distance to determine the length of the “flipping” skid.

For each hex of a flipping skid, the vehicle takes damage equal to its tonnage divided by 10 (rounded up). The vehicle takes damage on a different location for each hex it flips through.

**FAILED MANEUVER TABLES**

2D6 Roll	Effect
2-7	<b>Minor fishtail.</b> The attempted turn fails, and the MP are expended for the attempt. The vehicle can continue moving normally; it cannot attempt to make the turn in that hex, however, and must enter another hex before making another turn attempt.
8-9	<b>Moderate fishtail.</b> The vehicle immediately makes an additional 1-hexside facing change (at no MP cost) in the same direction as the controlling player originally intended. Ground vehicles roll once on the Motive System Damage Table (see p. 193, TW), with a -1 modifier.
10-11	<b>Serious fishtail.</b> The vehicle immediately makes an additional 1-hexside facing change (at no MP cost) in the same direction as the controlling player originally intended. Ground vehicles roll once on the Motive System Damage Table (see p. 193, TW). The vehicle's movement ends immediately.
12-13	<b>Skid.</b> The turn fails completely, ending the vehicle's movement. Apply Skidding rules (see <i>Ground Vehicles</i> , p. 62, TW).
14+	<b>Major Skid.</b> The driver loses control of the vehicle. Wheeled vehicles begin to flip over, taking damage to their side armor and turret(s) (see <i>Flipping Over</i> , at right). Tracked vehicles, VTOLs and hovercraft do not flip over; for them, treat this result as a normal skid (see <i>Ground Vehicles</i> , p. 62, TW). Naval vessels and hydrofoils capsize and sink, and are effectively destroyed.

Vehicle Type	Modifiers
Tracked, Naval	+0
Wheeled*, VTOL	+2
Hovercraft, WIGE, Hydrofoil	+4

\*Apply a -2 modifier if the wheeled vehicle occupies a paved hex when it failed the Driving Skill Roll.

Vehicle Weight Class	Modifiers
Light	+1
Medium	+0
Heavy	-1
Assault-Super-Heavy	-2



The first hex of the flip damages the armor on the vehicle side facing the skid's direction. The second hex of the flip damages the turret armor if the vehicle has a turret (if the vehicle has two turrets, both turrets take full damage); if the vehicle has no turret, apply the third-hex damage instead. The third hex of the flip damages the vehicle side opposite the skid's direction. The controlling player must roll on the Motive System Damage Table (see p. 193, *TW*) and add 1 to the result to determine the damage from the fourth hex. If the flip continues past four hexes, repeat the sequence, starting with the vehicle side facing the skid's direction.

In addition to armor damage, roll once on the Ground Vehicle Critical Hits Table (see p. 194, *TW*) for each side damaged. Make two rolls for a side if its armor is penetrated.

Finally, any vehicle that flips over takes a Crew Stunned critical hit that affects the vehicle for the remainder of the turn and all of the next turn.

## INFANTRY

The following additional rules apply to infantry movement.

### SQUAD DEPLOYMENT

In the field, conventional infantry units rarely operate in platoons. More often, each squad breaks off and operates individually. The following rule allows players to deploy infantry in squads rather than platoons.

Each squad consists of seven troopers. Jump infantry platoons consist of three squads, while all other types of platoons contain four squads. Normally, an infantry force participates in a scenario as a platoon, but is deployed in independent squads. In some cases, however, individual squads might take part in a battle.

An infantry squad is treated like a small platoon of seven troopers. However, 'Mechs and vehicles must apply a +1 modifier to the to-hit numbers for attacks against infantry squads in order to account for their spread-out formation and small size.

This modifier does not apply to infantry platoons reduced by damage to seven or fewer troopers—only to infantry initially deployed in squads.

A squad follows standard stacking limits unless it joins other squads from the same platoon. For purposes of stacking limits, squads from the same platoon count as a single unit while occupying the same hex. In addition, squads from the same platoon that occupy the same hex may join together to form a larger unit during the End Phase of a turn. From that point on, the unit is considered a standard infantry platoon consisting of the total surviving troopers from each squad.

### MOVEMENT ON PAVEMENT

If mechanized and motorized infantry meet the same criteria as Ground Vehicles when moving on pavement (see p. 61, *TW*), they receive a bonus of 1 MP.

### FAST MOVEMENT

Any infantry unit can forgo weapon and physical attacks in a turn to receive a bonus of 1 Ground MP during the Movement Phase of that turn. This can be combined with movement on pavement for mechanized and motorized infantry.

**0 MP Infantry:** If a unit must either move or fire, it can still gain an extra 1 Ground MP (in addition to its standard Ground MP when not firing in a turn) and make "fast movement", but the unit then cannot move or fire in the following turn.

### CLIMBING

Foot and jump conventional infantry units, as well as humanoid battle armor, can use Climbing rules to enter a hex that is 2 or more levels higher or lower than the hex they occupy.

Use all the rules from the 'Mech Climbing rules (see p. 22) with the following changes.

For foot and jump infantry, each level change still requires 2 Ground MP, though a unit with only 1 MP can use the Minimum Movement Rule (see p. 49, *TW*) to change a level while climbing. For battle armor, if they are capable of swarming, each level change only requires 1 MP; if the battle armor is not swarm-capable, then each level change requires 2 MP (the Minimum Movement rule, as noted above, also applies). Quad battle armor cannot use these climbing rules.

For each level climbed, the infantry unit makes an Anti-'Mech Skill Roll; apply a -1 modifier for swarm-capable battle armor. If the roll fails, the infantry falls from a height equal to the last level it successfully reached (use the Infantry Falling Damage Table, p 151, *TW*).

An infantry unit can make standard attacks while climbing, but apply a +2 to-hit modifier, as well as a +1 modifier to the Anti-'Mech Skill Roll made on the following turn during movement; swarm-capable battle armor only apply a +1 to-hit modifier and do not apply the additional +1 modifier to the following turn's Anti-'Mech Skill Roll.

**Buildings:** Infantry scaling buildings do not apply the additional +2 modifier inflicted against 'Mechs.

**Mountain Troops:** Mountain troops (see p. 341) apply a -2 modifier to any Anti-'Mech Skill Rolls and only expend 1 MP per 2 levels moved up or down (note that mountain troops can change 3 levels up or down, so a mountain troop unit will only need to use the Climbing rules if attempting to change 4 or more levels in a single hex). Finally, mountain troops can make standard attacks with no additional modifiers applied.

## MOVEMENT DICE (TIPS AND SUGGESTIONS)

Movement dice can help speed up and simplify game play, especially if a large number of units are on the board. Keep in mind, however, that movement dice are not a formal game mechanic—simply an option to make game play smoother. Therefore, all players should agree to their use before a game begins.

Players can use six-sided (D6) or ten-sided (D10) dice. With a ten-sided die, players can show 0 movement, and need not use multiple dice when movement and terrain provide a movement modifier greater than 6. However, players can easily use two six-sided dice to achieve the same result. Making sure the movement dice are a different size and/or color from those used for rolling to-hit numbers and so on is usually a good idea.

INTRODUCTION

ADVANCED  
GROUND MOVEMENT

ADVANCED  
COMBAT

ADVANCED  
BUILDINGS

ADVANCED  
SUPPORT  
VEHICLES

GENERAL  
RULES

ADVANCED  
SUPPORT VEHICLE  
CONSTRUCTION

ADVANCED  
WEAPONS  
AND EQUIPMENT

INDEX

RECORD SHEETS



Players use movement dice to keep track of each unit's movement. Different color dice can be used to show the movement mode chosen. Walk = Blue, Run = Yellow, Jump = Red, for example. This can be placed behind the unit before it starts its move, so players can remember where it started.

After a unit moves, place its movement die (or dice) directly in front of it. Turn the die (or dice) so that its upper side(s) shows the unit's target movement modifier. If the unit has a target movement modifier of 0, turn the die so that it shows a 0. If using six-sided dice, players can all agree that 6 represents 0. If they need to show a modifier of 6 or greater, they may use multiple six-sided dice. Movement dice enable all players to quickly and easily see which units have moved during a turn, along with each unit's target movement modifier. (No more need to ask your opponent, "How far did that *Spider* move this turn?")

Players can also use movement dice to show torso twists and turret rotations. After a unit twists or rotates its turret during the Weapon Attack Phase, simply move the unit's movement die from the front hexside to the hexside the unit's torso or turret now faces. If all players agree, they can use movement dice to show the appropriate terrain modifier for the unit's hex, as hex bases sometimes make it difficult to determine what terrain exists in a hex. For example, a *Spider* with a movement modifier of +2, standing in heavy woods (+2 terrain modifier), would have a total target movement modifier of +4.

During the End Phase, players should remove all movement dice from the board.

---

## PLANETARY CONDITIONS

---

Planetary conditions is a general term used to describe all terrain and weather types/conditions that can be used in a game.

The terrain type rules—such as woods, water, levels and so on—presented in *Total Warfare* (see *Mapsheets*, p. 31, *TW*), represent basic terrain types, particularly as they appear on the pre-printed mapsheets available in published map sets. However, this represents a small, and mostly mundane, fraction of the possible terrain types that can exist in a scenario to represent the myriad worlds that occupy the *BattleTech* universe. In addition, *Total Warfare*—as the standard rules set—does not delve into terrain modifications (such as ice, mud and so on), weather conditions or other situa-



*The Taurian Concordat reclaims a world regardless of its viability for human life.*

---

tions such as nighttime, and so on: conditions/situations that can also make any scenario more interesting and fun to play.

The following rules, which expand the terrain type rules in *TW*, are designed to simulate more exotic terrain types, while introducing terrain modifications, terrain conditions and weather conditions. In addition to covering their use in a game, these rules also allow for random assignment of planetary conditions to a given scenario.

Finally, these rules provide a means of meshing random generation of planetary conditions with the *Selecting Mapsheets* rules (see p. 262, *TW*).

**Combat:** In *Total Warfare*, the effects of terrain on movement and combat are dealt with in separate chapters. However, to make the various game effects of all terrain and weather types/conditions as easy to use and understand as possible—and to make sure that all such effects appear on a single set of tables for ease of reference—the rules for movement and combat are all explained in this chapter.

### EXPANDED MOVEMENT COST AND PLANETARY CONDITIONS RULES

The Expanded Movement Cost and Planetary Conditions Tables (see p. 32) summarizes the movement costs, Piloting Skill Roll modifiers and to-hit modifiers for each new planetary condition and how it applies to various units; this includes any new movement actions as well. For the sake of completeness, all terrain types and movement actions covered on the Movement Costs Table in *Total Warfare* (see p. 54) are included on this table.

The to-hit modifiers listed on the table may only apply to a specific type of weapon (that is, direct-fire energy, direct-fire ballistic, missile and so on), or a specific unit type (Mech, Combat Vehicle, conventional infantry and so on). Players should therefore be sure to verify the specific effects of a given planetary condition's to-hit modifier by reading the specific rules governing a given planetary condition.

The Piloting/Driving modifiers listed in the table apply to any Piloting/Driving Skill Roll a player makes while operating a unit within a specific planetary condition. The rules that follow the table explain any required Piloting/Driving Skill Rolls for each new planetary condition (as well as covering units that do not have Piloting Skills, such as infantry and ProtoMechs, where appropriate). Do not assume that a Piloting/Driving Skill Roll is required to enter a particular planetary condition simply because a Piloting/Driving modifier is listed for that condition.

The Terrain/Construction Factor column is used when players are using the Terrain Factor rules (see p. 64), or to note the Construction Factor of buildings (see p. 166, *TW* and p. 121). If a row on the table has a "0" in this column, then that planetary condition can never be changed during a given game.

Finally, the table's Prohibited Units column lists the types of units prohibited from entering each terrain or prohibited from functioning under a particular planetary condition.

**Note:** Every effort has been made to make the Expanded Movement Costs and Planetary Conditions Table as comprehensive as possible. However, the nature of these rules means it is important—at least the first few times that players use a given planetary condition—for all players to read the specific rules in question, using the table only as a quick reference guide during game play.

In the case of some planetary conditions, the rules are simply too complex to distill into the table; in such instances, the table will refer players to the specific rule, where often a more tailored and expanded table exists to explain it.



## Units and Planetary Conditions

Various planetary conditions listed on the Expanded Movement and Planetary Conditions Table affect units differently. Once players have determined what units will be involved in a game, they should make sure that the specific planetary conditions they wish to use in a game have an effect on the units they intend to field.

If players are randomly determining planetary conditions (see *Planetary Conditions Tables*, p. 69), when a given planetary condition is rolled, the players should make sure it will have an effect on the units fielded in the game.

If the desired (or rolled) planetary condition has no effect (for example, if the players are only fielding 'Mechs and the planetary conditions rolled have no effect on 'Mechs), players may feel free to choose another condition (or re-roll, if randomly determining such effects) to make sure the planetary conditions they are adding will actually affect game play.

## Base Terrain, Terrain Modifications, Terrain Conditions and Weather Conditions

As noted, planetary conditions is a general term used to describe terrain and weather types/conditions. However, by adding so many new terrain options—not to mention weather options—the rules for terrain become a bit more complex. This requires specific definitions that go beyond the Terrain Type column shown on the Movement Costs Table and Attack Modifiers Table (see pp. 52 and 117 respectively, *TW*), as outlined below.

**Base Terrain:** Base terrain represents the underlying terrain of a battlefield; the complete rules for base terrain start on p. 30. Every hex on every mapsheet must consist of a base terrain type as shown on the Expanded Movement Costs and Planetary Conditions Tables. As noted above, the Base Terrain portion of the Expanded Movement Costs and Planetary Conditions Table includes those terrain types described in detail in *TW*, as well as all new base terrain types. Unless specifically noted otherwise under *Base Terrain Types* (see p. 30), no two base terrain types can be found in the same hex.

**Terrain Modifications:** Terrain modifications represent specific additions to base terrain and are applied on a hex-by-hex basis (see the Expanded Movement Costs and Planetary Conditions Tables, p. 32, for a complete list of terrain modifications); the complete rules for terrain modifications start on p. 40.

Page 49 of *Total Warfare* notes that when multiple terrain types are found in the same hex, all appropriate modifiers are cumulative. That rule applies here as well. When base terrain and terrain modifications appear in the same hex, all appropriate modifiers are cumulative.

**Terrain Conditions:** Terrain conditions represent specific modifications to the playing area, but unlike terrain modifications, they are applied across the entire playing area (see the Expanded Movement Costs and Planetary Conditions Tables, p. 32, for a complete list of terrain conditions). In other words, terrain conditions reflect more exotic situations representing a global change to the terrain of the playing area—things that don't fall under the heading of weather, such as vacuum, heavy or light gravity and so on. The complete rules for terrain conditions start on p. 54.

Terrain conditions are cumulative with all appropriate modifiers for base terrain and terrain modifications.

**Weather Conditions:** Weather conditions represent specific modifications to the playing area, but, like terrain conditions, they are applied across the entire playing area (see the Expanded Movement Costs and Planetary Conditions Tables, p. 32, for a complete list of weather conditions); the complete rules for weather conditions start on p. 57.

As with the other three types of planetary conditions, weather conditions are cumulative with all appropriate modifiers from base terrain, terrain modifications and terrain conditions.

## Assigning Planetary Conditions

As players set up a game and wish to use planetary conditions in a given scenario, they can look through the Expanded Movement Costs and Planetary Conditions Tables—as well as the specific rules of the various Planetary Conditions—and choose what they will include in their game.

Note, however, that some planetary conditions are easier to use in a given scenario than others. For example, most terrain conditions and weather conditions apply universally across a playing area. However, when using new base terrain types, or terrain modifications, as noted above, they must be tracked hex by hex. Since most pre-printed maps do not include these more advanced planetary conditions, players can use pre-made counters, create their own counters, or simply write the hex numbers on a sheet of paper—along with what base terrain types and terrain modifications appear in that hex—to track the various planetary conditions in a given scenario.

Alternatively, players can use the HeavyMetal Map program to generate their own maps, based on the various planetary conditions they wish to use in a given scenario (see *HeavyMetal Software*, p. 13, *TW*).

## Conflicting Planetary Conditions

Note that regardless of attempts to make the various planetary conditions rules as thorough as possible in how they apply to one another—for example, many rules have a “prohibited” aspect that notes which conditions should not be used with a given rule—situations will arise when player adjudication will be needed. For example, if the extreme (hot) temperature weather condition is in play, then it would be unlikely for ice, deep snow or snowfall to appear on the same playing area.

In the mud/heavy jungle/deep snow hex example noted below, while it would be perfectly okay if players wanted to stack all that in the same hex, common sense dictates that the mud will likely have frozen. In this case, instead of mud, the hex could be considered rough: this choice imposes the same MP requirement to enter the hex for a 'Mech, but removes the possibility of getting stuck. Such changes will help make a given game feel more in sync with “reality.”

With that in mind, as each new base terrain, terrain modification, terrain condition and weather condition is added (whether the players are simply choosing each planetary condition or are randomly determining them; see *Planetary Conditions Tables*, p. 69), such a “reality litmus test” should be applied, with the most recently added planetary condition changed if it doesn't pass such a test for all players. Furthermore, depending on the complexity of planetary conditions involved in a given scenario, once all the planetary conditions have been chosen and then applied to the playing area, players may wish to make sure that no such extremes exist in a given hex.

INTRODUCTION

ADVANCED  
GROUND MOVEMENT

ADVANCED  
COMBAT

ADVANCED  
BUILDINGS

ADVANCED  
SUPPORT  
VEHICLES

GENERAL  
RULES

ADVANCED  
SUPPORT VEHICLE  
CONSTRUCTION

ADVANCED  
WEAPONS  
AND EQUIPMENT

INDEX

RECORD SHEETS



In the end, of course, if your playing group doesn't mind deep snow in a lava hex, then by all means, have fun!

In the Planetary Conditions diagram above, a 'Mech with 3 Walking MP and 5 Running MP, as well as a Motorized SRM Conventional Infantry Platoon with 2 Ground MP, are attempting to move on the Open Terrain #2 map. During game set-up, the players determined that they wanted to add additional exotic base terrain types, terrain modifications and weather conditions (they decide not to add any terrain conditions). In the end, the Ultra-Heavy Jungle base terrain type and Mud terrain modification are applied to Hex B, while the Deep Snow terrain modification is added to both Hex B and Hex C. Finally, a Blizzard weather condition is applied to the entire playing area.

If the controlling player wished to move the 'Mech in Hex A to Hex B, it would require 4 MP [1 (entering the hex) + 1 (Light Woods) + 1 (Deep Snow) = 4]; the 'Mech would have to run to enter the hex. However, the controlling player cannot move the 'Mech into Hex B, as a 'Mech cannot enter an ultra-heavy jungle hex.

If the controlling player wished to move the infantry in Hex A to Hex B, it would require 3 MP [1 (entering the hex) + 0 (infantry do not pay any MP for Light Woods) + 1 (Deep Snow)]. As the infantry unit only has 2 Ground MP, it cannot enter the hex normally. However, the infantry could enter the hex using the Minimum Movement rule (see p. 49, TW).

If the controlling player wished to move the infantry in Hex A to Hex C, it would require 6 MP [1 (entering the hex) + 3 (infantry pay 1 less MP to enter an Ultra-Heavy Jungle hex), +1 (Mud) + 1 (Deep Snow) = 6]. Once again, the infantry unit does not have 6 MP, but since it is not prohibited from entering an ultra-heavy jungle, mud or deep snow hex, it can use the Minimum Movement rule, as noted above, to enter the hex.

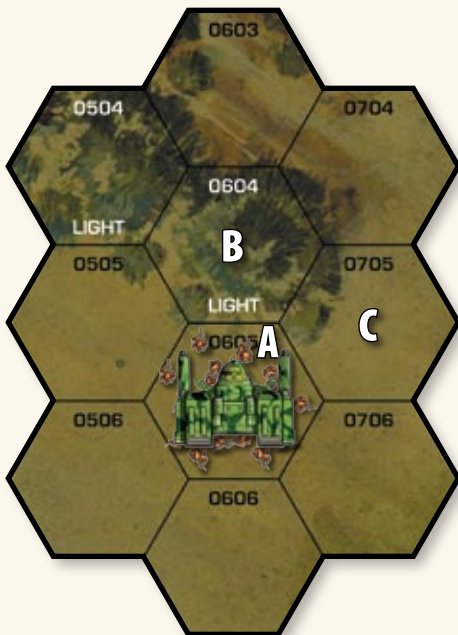

• GROUND MOVEMENT-PLANETARY CONDITIONS DIAGRAM •

As a final note on movement, even though both the Mud and Deep Snow terrain modifications can cause the infantry unit to get stuck, only a single roll is made upon entering the hex to determine if that happens (see Bog Down Rules, p. 62).

During combat, if either unit wished to fire into Hex B, it would apply a +3 to-hit modifier to all direct-fire ballistic weapons [1 (Light Woods) + 2 (Blizzard) = 3], while applying a +2 to-hit modifier to all other weapon attacks [1 (Light Woods) + 1 (Blizzard) = 2].

If either unit wished to fire into Hex C, it would apply a +5 to-hit modifier to all direct-fire ballistic weapons [3 (Ultra-Heavy Jungle) + 2 (Blizzard) = 5], while applying a +4 to-hit modifier to all other weapon attacks [3 (Ultra-Heavy Jungle) + 1 (Blizzard) = 4].

## BASE TERRAIN TYPES

The following section describes in detail the new base terrain types introduced in *Tactical Operations*. This includes completely new terrain—such as gravel piles, jungle, sand and so on—as well as expanding upon terrain found in *Total Warfare*, such as ultra-heavy woods and extreme depths, which expand upon the standard Light and Heavy Woods and Water terrain.

### Buildings

Though buildings are considered base terrain types, they are covered in their own section, as well as in *Total Warfare* (see p. 114, of this rulebook and p. 166, TW, respectively).

### Gravel Piles

Gravel piles represent any type of rock or dirt piles that are not compacted; they are all covered under a single set of rules. While gravel piles can be designated on any hex on the playing area, only the hex's level is still considered for the game; any other terrain condition (woods, water and so on) is ignored.

**Determining Gravel Piles:** Unlike most other base terrain types, players must determine the number of hexes each pile covers, as well as the level each hex rises above the underlying terrain. Because such non-compacted piles are inherently unsteady, a hex cannot rise more than 1 level higher than adjacent hexes of the same base terrain type.

In other words, at the start of a game, if the players wish to designate a single gravel pile hex, it can only be a single level higher than the underlying terrain. If the players wish to have a gravel pile that is higher than a single level, then all six adjacent hexes must have Level 1 gravel piles and/or hills, which will allow the central hex to be a Level 2 gravel pile. If the players wish the central gravel pile hex to be a Level 3 gravel pile, the 6 adjacent hexes must be Level 2 gravel piles and/or hills, while the 12 adjacent hexes to those 6 hexes must be a Level 1 gravel pile and/or hill. And so on.

**Game Effects:** Apply a +1 MP cost to enter a Level 1 gravel pile hex, and apply a +1 modifier to all Piloting/Driving Skill Rolls made in a gravel pile hex. Both modifiers increase by 1 for each gravel pile hex level above 1, so that entering a Level 3 gravel pile hex would require an additional +3 MP cost and would inflict a +3 modifier to any Piloting/Driving Skill Rolls made in that hex.

Units entering a gravel pile equal to or greater than their height level may get stuck (see *Bog Down Rules*, p. 62). However, unlike all other terrain types, a failed Bog Down roll means the unit is not only stuck, but has sunk down into the gravel pile the exact number of levels equal to the unit's height, which means that all LOS to and



from the unit is blocked. The unit must apply an additional +2 modifier to the Bog Down roll when attempting to get unstuck. If the roll succeeds, the unit may then move normally.

- **Vehicles:** Hover vehicles may not enter a gravel pile hex; wheeled vehicles may not enter a Level 2 or higher gravel pile hex; Large Vehicles still pay the +1 MP cost to enter a gravel pile hex, but ignore the Piloting/Driving Skill Roll modifier and never check to see if they are stuck.
- **Infantry:** Infantry do not pay the additional MP cost to enter a gravel pile hex; though they may get stuck, unlike other unit types, they do not sink into the terrain of the hex and so LOS is not blocked.
- **Non-Spheroid Aerospace Units:** If a unit is landing or taking off and enters a gravel pile hex, apply the damage as though it crashed into the hex (see *Landing*, p. 87, *TW*), but the unit continues moving, only subtracting 1 hex from the total number of hexes needed to land, for each gravel pile hex the unit enters. Damage is still applied for each gravel pile hex entered separately, however.
- **Spheroid Units:** Landing Spheroid units reduce gravel pile hexes to the level of the underlying terrain. In doing so, they create a Level 1 gravel pile in each hex adjacent to the DropShip. If the level of the underlying adjacent hex is 6 or greater for Spheroid DropShips, or 3 or greater for Spheroid Small Craft, ignore this effect.

### Half Levels

The effect of half-levels on movement is shown on the Expanded Movement Costs and Planetary Conditions Tables (see p. 32). Additionally, half-levels allow vehicles to go hull-down, if that rule is in use (see *Hull Down Vehicles*, p. 121).

### Heavy Industrial Zone

A heavy industrial zone hex must be assigned to a clear or paved hex, within 3 hexes of a building hex on the playing area. This represents the convoluted apparatus (power lines, generators, cooling ponds, water towers and so on) that make up a heavy industrialized sector.

**All Units:** Apply a +1 to-hit modifier to all weapon attacks made into or through a heavy industrial zone hex. Just as with woods hexes, 3 intervening hexes of heavy industrial zone blocks line of sight.

Unlike other terrain, which always has a specific height, players must assign a height to each heavy industrial zone hex. Some apparatus can be a half-level, one level or two levels tall, while truly massive industrial zones can tower as high as a DropShip at ten levels. As each heavy industrial zone hex is assigned, designate its height for LOS purposes.

**'Mechs:** Apply +1 MP for a 'Mech to enter a heavy Industrial zone hex.

**Unintended Explosions:** Every weapon fired into a heavy industrial zone hex that does not strike its intended target (including missiles, if the maximum number fired did not strike) may cause a potentially devastating explosion of some sort; likewise, area-effect attacks (such as artillery strikes) and attacks to reduce the hex (see *Terrain Factor Rules*, p. 64) may also cause such an explosion. Roll 2D6 for every qualifying weapon attack; on a result of 8 or higher, consult the Terrain Effects Table. All damage is inflicted to the front of an affected unit; damage is inflicted to each trooper in a battle armor unit;

double the damage inflicted to all conventional infantry units in the hex, dealing damage as if the attack originated from another infantry unit.

Note that this rule applies whether or not the Missed Shots rule (see p. 81) is in use.

**Non-Spheroid Aerospace Units:** If a unit is landing or taking off and enters a heavy industrial zone hex, immediately make a roll on the Terrain Effects Table and apply any resulting damage before finishing the unit's landing; if a unit enters multiple heavy industrial zone hexes, a separate roll is made for each hex.

If the landing unit is an Aerodyne DropShip, add a +2 modifier to the die roll.

**Spheroid Aerospace Units:** If a Spheroid DropShip lands in a heavy industrial zone hex, immediately make a roll on the Terrain Effects Table with a +4 modifier (apply a +2 modifier for Spheroid Small Craft); a separate roll is made for each heavy industrial zone hex the landed DropShip covers. If a heavy industrial zone hex entered by a landing Spheroid aerospace unit is Level 6 or higher, roll twice on the table.

**Airships:** An Airship entering a heavy industrial zone hex automatically rolls three times on the Terrain Effects Table.

**Fire:** During the End Phase of any turn when a heavy industrial zone hex is on fire, roll once on the Terrain Effects Table and apply effects, if any.

### Jungle

Apply the modifiers shown on the Expanded Movement Costs and Planetary Conditions Tables for movement into jungle hexes.

Jungle hexes affect line of sight and weapons fire in the same manner as woods hexes (see p. 100, *TW*); the ultra-heavy jungle hex affects line of sight and weapons fire just like ultra-heavy woods (see p. 40).

**Chainsaw:** A chainsaw can be used to reduce a jungle hex just like a woods hex (see p. 134, *TW*), except that it take three turns instead of two to reduce a jungle hex from its current state to one lower.

## TERRAIN EFFECTS TABLE

Die Roll	Effect
2-7	No effect
8	Hex catches fire (see <i>Fire</i> , p. 43).
9	Power lines fall: all units in hex take 3 points of damage to a random location
10	Minor explosion: all units in hex take 5 points of damage to a random location; hex catches fire
11	Electrical explosion: all units in hex take 1D6 + 3 points of damage to a random location
12	Major explosion: all units in hex take 2D6 points of damage to a random location and catch fire for 1D6 turns; hex catches fire

**Note:** All conventional infantry units in the hex suffer double damage and the damage is applied as though it were an attack from another infantry unit. If tracking damage in such hexes (see *Terrain Factor*, p. 64), double the damage applied to any units to the heavy industrial zone.

INTRODUCTION

ADVANCED  
GROUND MOVEMENT

ADVANCED  
COMBAT

ADVANCED  
BUILDINGS

ADVANCED  
SUPPORT  
VEHICLES

GENERAL  
RULES

ADVANCED  
SUPPORT VEHICLE  
CONSTRUCTION

ADVANCED  
WEAPONS  
AND EQUIPMENT

INDEX

RECORD SHEETS



## EXPANDED MOVEMENT COSTS AND PLANETARY CONDITIONS TABLES

The following abbreviations can be found on the following tables: 'Mechs = M; ProtoMechs = P; Vehicles = V; Tracked Vehicles = T; Hover Vehicle = H; Wheeled Vehicles = W; WiGE = Wi; VTOL = VT; Airships = A; Infantry = I; Conventional Infantry = CI; Battle Armor = B; Missile = Mi; Dire-Fire Ballistic = DB; Direct-Fire Energy = DE; Physical Attack = PH

Movement Action/ Base Terrain Type	MP Cost Per Hex/ Terrain Cost	To-Hit Modifier	Piloting/Driving Skill Modifier	Terrain/ Construction Factor	Prohibited Units
<b>Cost to Enter Any Hex</b>	1				
<b>Base Terrain Cost When Entering Any New Hex</b>					
Clear	+0 <sup>6</sup>	+0	+0	200	Rail; <sup>21</sup> Naval Vessels
Gravel Piles	+1 per level	+0	+1 per level	100	Rail; <sup>21</sup> Naval Vessels
Rough	+1	+0	+0	200	Wheeled, Rail; <sup>21</sup> Naval Vessels
Ultra Rough	+2	+0	+0	200	Vehicles, Rail; <sup>21</sup> Naval Vessels
Light Woods	+1 <sup>10</sup>	+1	+0	50	Wheeled <sup>9</sup> , Hover, VTOL; <sup>12</sup> WiGE; <sup>12</sup> Rail, Naval Vessels
Heavy Woods	+2 <sup>11</sup>	+2	+0	90	Vehicles; <sup>12</sup> Rail; <sup>21</sup> Naval Vessels
Ultra-Heavy Woods	+3	+3	+0	120	'Mechs, ProtoMechs, Vehicles; <sup>12</sup> Rail; <sup>21</sup> Naval Vessels
Light Jungle	+2	+1	+1	60	Vehicles; <sup>12</sup> Rail; <sup>21</sup> Naval Vessels
Heavy Jungle	+3	+2	+2	100	Vehicles; <sup>12</sup> Rail; <sup>21</sup> Naval Vessels
Ultra-Heavy Jungle	+4	+3	+3	130	'Mechs, ProtoMechs, Vehicles; <sup>12</sup> Rail; <sup>21</sup> Naval Vessels
Magma Crust	+0	+0	+1	30	Wheeled, Infantry, Rail, Naval Vessels
Magma, Liquid	+1 <sup>24</sup>	+0	+4	0	Wheeled, Hover, Tracked, Infantry, Rail, ProtoMechs Naval Vessels
Planted Fields	+0	p. 38	+0	30	Rail; <sup>21</sup> Naval Vessels
Rail	+0	+0	+0	20	Naval Vessels
Tundra	+0 <sup>6</sup>	+0	+1	70	Rail; <sup>21</sup> Naval Vessels
Sand	+0 <sup>5</sup>	+0	+1	100	Rail; <sup>21</sup> Naval Vessels
Water <sup>17</sup>					
Depth 0	+0	+0	+0	—	Rail; <sup>21</sup> Naval Vessels
Depth 1	+1 <sup>1</sup>	+0	+0	—	Infantry; <sup>4</sup> Vehicles; <sup>7</sup> Rail <sup>21</sup>
Depth 2–15	+3 <sup>1</sup>	+0	+0	—	Infantry; <sup>4</sup> Vehicles; <sup>7</sup> Rail; <sup>21</sup> IndustrialMechs <sup>8</sup>
Depth 16+	p. 42	p. 42	p. 42	—	p. 42
<b>Level Change (up or down)</b>					
Half Levels	+1 (+0 for 'Mechs)	+0	+0	150	
1 level	+1 ('Mechs, VTOLs, subs, ProtoMechs) +2 (infantry, ground vehicles)	+0	+0	200	—
2 levels	+2 ('Mechs, VTOLs, subs)	+0	+0	—	Infantry, Ground Vehicles, WiGE; <sup>13</sup> Rail; <sup>21</sup> ProtoMechs
3+ levels	+1/level (VTOLs, subs)	+0	+0	—	'Mechs, ProtoMechs, Infantry, Ground Vehicles, Rail, WiGE <sup>13</sup>
Sheer Cliffs	p. 39	+0	p. 39	50	Rail; <sup>21</sup> Naval Vessels
Rubble	+1	+0	+0	0	Rail, Naval Vessels
Ultra Rubble	+2	+0	+1	0	Rail, Naval Vessels

<sup>1</sup>MP cost to move along the bottom of the water hex; Piloting Skill Roll required to prevent falling.

<sup>2</sup>Piloting Skill Roll required to prevent damage; infantry pays only 1 MP (except mechanized infantry, which pays 2 MP) to enter any building hex.

<sup>3</sup>If traveling along road; otherwise cost of underlying terrain.

<sup>4</sup>Hovercraft may enter all water hexes along the surface and may enter such hexes using Flanking movement.

<sup>5</sup>No cost for infantry.



## EXPANDED MOVEMENT COSTS AND PLANETARY CONDITIONS TABLES (CONT.)

Movement Action/ Base Terrain Type	MP Cost Per Hex/ Terrain Cost	To-Hit Modifier	Piloting/Driving Skill Modifier	Terrain/ Construction Factor	Prohibited Units
<b>Buildings<sup>2</sup></b>					
Tent	+0	+0	—	—	VTOL, WiGE, Rail; <sup>21</sup> Naval Vessels
Hangar <sup>18</sup>		Blocks LOS			VTOL, WiGE, Rail; <sup>21</sup> Naval Vessels
Light	+0		+0	1–8	
Medium	+1		+0	9–16	
Heavy	+2		+1	17–45	
Hardened	+3		+3	46–75	
Standard		Blocks LOS			VTOL, WiGE, Rail; <sup>21</sup> Naval Vessels
Light	+1		+0	1–15	
Medium	+2		+1	16–40	
Heavy	+3		+2	41–90	
Fence	+1 <sup>19</sup>	+0	—	1	VTOL, WiGE, Rail; <sup>21</sup> Naval Vessels
Wall		Blocks LOS			VTOL, WiGE, Rail; <sup>21</sup> Naval Vessels
Light	+1		+0	1–15	
Medium	+2		+0	16–40	
Heavy	+3		+1	41–90	
Hardened	+4		+3	91–150	
Bridge <sup>20</sup>					Rail; <sup>21</sup> Naval Vessels
Light	NA	+0	NA	1–15	
Medium	NA	+0	NA	16–40	
Heavy	NA	+0	NA	41–90	
Hardened	NA	+0	NA	91–150	
Rail	NA	+0	NA	151–600	
Gun Emplacement		Blocks LOS			VTOL, WiGE, Rail; <sup>21</sup> Naval Vessels
Light	NA		NA	1–15	
Medium	NA		NA	16–40	
Heavy	NA		NA	41–90	
Hardened	NA		NA	91–150	
Fortress		Blocks LOS			VTOL, WiGE, Rail; <sup>21</sup> Naval Vessels
Medium	+3		+2	16–40	
Heavy	+4		+3	41–90	
Hardened	+5		+4	91–150	
Castles Brian		Blocks LOS			VTOL, WiGE, Rail; <sup>21</sup> Naval Vessels
Heavy	+4		+4	35–90 <sup>15</sup>	
Hardened	+5		+5	91–150 <sup>15</sup>	
Heavy Industrial Zone	+0 <sup>16</sup>	+1	+1	100	Rail; <sup>21</sup> Naval Vessels

<sup>6</sup>If a Wheeled Support Vehicle lacks the Off-Road Vehicle Chassis and Controls modification, then movement costs 1 additional MP per hex.

<sup>7</sup>Wheeled or Tracked Support Vehicles with the Amphibious Chassis and Controls modification can move through any water hex on the surface at a cost of 2 MP (see p. 56, *TW*).

<sup>8</sup>IndustrialMechs can enter a Depth 2 or greater water hex. However, the IndustrialMechs must mount either a fuel cells, fission or fusion power plant and must mount the Environmental Sealing Chassis and Controls modification to do so. If the IndustrialMech does not meet those requirements, it is considered destroyed if it remains in a Depth 2 or greater water hex (or prone in a Depth 1 water hex) in the End Phase of the turn immediately following the turn in which it entered the hex.

<sup>9</sup>Wheeled Support Vehicles with either the Monocycle or Bicycle Chassis and Controls modification can enter a light woods hex.

<sup>10</sup>Infantry pays only 1 MP (except mechanized infantry, which pays 2 MP) to enter any light woods hex.

<sup>11</sup>Infantry pays only 2 MP (except mechanized infantry, which pays 3 MP) to enter any heavy woods hex.

<sup>12</sup>VTOL and WiGE vehicles can enter a woods/jungle hex provided their elevation is higher than the level of the woods in the hex.

INTRODUCTION

ADVANCED  
GROUND MOVEMENT

ADVANCED  
COMBAT

ADVANCED  
BUILDINGS

ADVANCED  
SUPPORT  
VEHICLES

GENERAL  
RULES

ADVANCED  
SUPPORT VEHICLE  
CONSTRUCTION

ADVANCED  
WEAPONS  
AND EQUIPMENT

INDEX

RECORD SHEETS



## EXPANDED MOVEMENT COSTS AND PLANETARY CONDITIONS TABLES (CONT.)

Movement Action/ Base Terrain Type	MP Cost Per Hex/ Terrain Cost	To-Hit Modifier	Piloting/Driving Skill Modifier	Terrain/ Construction Factor	Prohibited Units
<b>Additional Movement Actions</b>					
Climbing ('Mechs only)	2 MP or 3MP (1 arm)	+0	+1 or +2 (1 arm)	—	
Crawling ('Mechs only)	Half current Walking MP	+0	p. 20	—	
Dangle-and-Drop ('Mechs only)	p. 22	+0	p. 22	—	
Dropping to the Ground ('Mechs only)	1	+0	+0	—	
Evading	+0	+0	+1	—	Vehicles, Rail, Naval Vessels
Facing Change	1/hexside <sup>5</sup>	+0	+0	—	Infantry
Hull-down	+2	+0	+0	—	Rail, Naval Vessels, Infantry
Hurried Movement	+0	+0	+2 per MP ignored	—	Rail, Naval Vessels, Infantry
Leaping ('Mechs only)	4 MP	+0	p. 22	—	
Physical Defense ('Mechs only)	p. 20	p. 20	p. 20	—	
Shielding	Only Walking/Cruising MP	+0	+0	—	Rail, Large Naval Support Vessels
Sprinting ('Mechs only)		+0	+0	+2	—
Standing Still (Expanded)	+0	-1	+0	—	—
Standing Up	+0	+0	2/attempt	—	Vehicles, Rail, Naval Vessels, Infantry

Terrain Modification	MP Cost Per Hex/ Terrain Cost	To-Hit Modifier	Piloting/Driving Skill Modifier	Terrain/ Construction Factor	Prohibited Units <sup>25</sup>
Black Ice	+1 <sup>22, 23, 27</sup>	+0	+4	40	—
Bug Storm	p. 40	+1 DB, Mi/+2 DE, Pulse	+0	—	—
Deep Snow	+1 <sup>23</sup>	+0	+1	20	Wheeled
Extreme Depths	p. 42	p. 42	p. 42	0	p. 42
Fire	p. 43	p. 43	p. 43	0	p. 43
Geyser	p. 48	p. 48	p. 48	—	p. 48
Hazardous Liquid Pools	p. 49	p. 49	p. 49	—	p. 49
Ice	+1 <sup>22, 23, 27</sup>	+0	+4	40	—
Mud	+1 <sup>23, 24</sup>	+0	+1	—	Rail <sup>21</sup>
Rail	+1	+0	+0	20	Naval Vessels
Rapids	+1 <sup>24</sup>	+0	+2	—	—

<sup>13</sup>This only applies to WiGE units entering a hex whose level is higher than the unit's current hex; see *Wing-In-Ground-Effect*, p. 55, *TW*, for rules governing entering hexes whose level is lower than the unit's current hex.

<sup>14</sup>Infantry can enter a water hex of Depth 1 or deeper if they are noted as having UMU MP.

<sup>15</sup>Castles Brian use capital-scale damage, as noted under Scale (p. 238, *TW*). See *Scaled Damage* (p. 126) for more information.

<sup>16</sup>Mechs pay 1 additional MP to enter any heavy industrial zone hex.

<sup>17</sup>Level change MP cost not included.

<sup>18</sup>Infantry (except mechanized infantry) pay only 1 MP to enter a building hex regardless of building type; ProtoMechs and mechanized infantry pay only 2 MP to enter any building hex except for tents and fences (which cost only 1 MP). Hangars apply MP and Piloting Skill modifiers only when entering from outside, unless other factors apply (see *Hangars* for details).

<sup>19</sup>Only applies to conventional infantry using Ground MP.

<sup>20</sup>Units move over bridges (never through them) as though traveling on a road.

<sup>21</sup>Unless rail tracks also exist in the hex; if the hex is a water hex, the track must be mounted on a bridge, or the rail must mount the Environmental Sealing Chassis and Controls Modification

<sup>22</sup>Skidding rules apply (see p. 62, *TW*)



## EXPANDED MOVEMENT COSTS AND PLANETARY CONDITIONS TABLES (CONT.)

Terrain Modification	MP Cost Per Hex/ Terrain Cost	To-Hit Modifier	Piloting/Driving Skill Modifier	Terrain/ Construction Factor	Prohibited Units <sup>25</sup>
Road					
Paved	+1 (T/H/I) <sup>3</sup>	+0	+0	150	Rail <sup>21</sup> Naval Vessels
Gravel	+1 (V/I) <sup>3</sup>	+0	+0	50	Rail <sup>21</sup> Naval Vessels
Dirt	+1 <sup>3</sup>	+0	+0	20	Rail <sup>21</sup> Naval Vessels
Paved	+0 <sup>3</sup>	+0	+0	150	Rail <sup>21</sup> Naval Vessels
Smoke					
Light Smoke	+0	+1	+0	—	—
Heavy Smoke	+0	+2	+0	—	—
Swamp	+1 (M), +2 (V/I) <sup>23, 24</sup>	+0	+0	—	—
Thin Snow	+1 (W/CI) <sup>23</sup>	+0	+0	10	Rail <sup>21</sup> Naval Vessels
Torrent	+2	+0	+3	—	Rail <sup>21</sup>

Terrain Condition	Movement Modifier	To-Hit Modifier	Piloting/Driving Skill Modifier	Terrain/ Construction Factor	Prohibited Units <sup>25</sup>
Atmospheric Pressures (Density)					
Vacuum	+0	+0	+0	—	Vehicles <sup>26</sup> Infantry <sup>27</sup>
Trace	+0	+0	+0	—	Vehicles <sup>26</sup> Infantry <sup>27</sup>
Thin	-2 Cruising MP (H, Wi, VT)	+0	+0	—	—
Standard	+0	+0	+0	—	—
High	+1 Cruising MP (H, Wi, VT)	+0	+0	—	—
Very High	+1 Cruising MP (H, Wi, VT)	+0	+0	—	—
Earthquake	+0	+1 to +5	+1 to +5	—	—
Electromagnetic Interference	+0	+2 (-2 Cluster Table)	+0	—	—
High/Low Gravity	p. 55	+0	p. 55	—	—
Meteor Showers	+0	+0	+0	—	—
Tainted and Toxic Atmospheres	+0	+0	+0	—	Vehicles <sup>26</sup> Infantry <sup>27</sup>

<sup>23</sup>These terrain modifier do not apply to hover, WIGE or airborne VTOL vehicles; in the case of snow, does not apply to the unit if it mounts the Snowmobile Chassis and Controls Modification

<sup>24</sup>Units entering this terrain may be stuck; see *Bog Down Rules*, p. 62.

<sup>25</sup>Includes restrictions for underlying terrain as noted under Base Terrain Types

<sup>26</sup>A vehicle must include Environmental Sealing to operate under this condition; WIGEs and VTOLs can never operate under this condition.

<sup>27</sup>This only applies to conventional infantry, unless the conventional infantry are XCT Troops (see p. 351), in which case they can operate in this condition.

<sup>28</sup>A non-infantry unit entering this terrain may choose to ignore the additional MP cost. However, the unit may fall or crash as a result; see *Careful Movement*, p. 63.

<sup>29</sup>An MP Cost Per Hex is noted simply as a modifier, such as "+1" or "+2". A Movement Modifier is noted as a change in Movement Points, such as "-1 SF" means "-1 Safe Thrust," "-1 C" means "-1 Cruising MP," and so on; infantry will simply indicate an MP reduction, such as "-1 G" means "-1 Ground," "-1" which would apply to both Ground or Jumping movement, or "no J" means "no Jumping" and so on.

<sup>30</sup>If a specific weapon type is not noted, the modifier applies to all weapon attacks; a "PH" indicates a Physical Attack modifier.

<sup>31</sup>Hover, WIGE and VTOL Vehicles cannot operation in such conditions.

<sup>32</sup>At the start of Turn 5 of a scenario, includes all modifiers and effects of thin snow (see p. 52). At the start of Turn 15 of a scenario, includes all modifiers and effects of deep snow (see p. 41). At the start of Turn 20 of a scenario, includes all modifiers and effects for ice (see p. 50).

<sup>33</sup>At the start of Turn 10 of a scenario (provided the scenario lasts long enough), an ice storm includes all modifiers and effects of ice (see p. 50); ice occurs in every water hex across the playing area.

<sup>34</sup>At the start of Turn 10 of a scenario, includes all modifiers and effects of thin snow (see p. 52). At the start of Turn 20 of a scenario, includes all modifiers and effects of deep snow (see p. 41). At the start of Turn 20 of a scenario includes all modifiers and effects of ice (see p. 50).

<sup>35</sup>At the start of Turn 15 of a scenario, includes all modifiers and effects of ice (see p. 50); ice occurs in every water hex across the playing area.

INTRODUCTION

ADVANCED  
GROUND MOVEMENT

ADVANCED  
COMBAT

ADVANCED  
BUILDINGS

ADVANCED  
SUPPORT  
VEHICLES

GENERAL  
RULES

ADVANCED  
SUPPORT VEHICLE  
CONSTRUCTION

ADVANCED  
WEAPONS  
AND EQUIPMENT

INDEX

RECORD SHEETS



## EXPANDED MOVEMENT COSTS AND PLANETARY CONDITIONS TABLES (CONT.)

Weather Condition	MP Cost Per Hex or Movement Modifiers <sup>29</sup>					Heat Points	To-Hit Modifier <sup>30</sup>	Piloting/Driving/Control Modifier		
	'Mechs	Vehicles	Infantry	Aerospace	Aerospace			'Mechs	Vehicles	Aerospace
Fog <sup>28</sup>										
Heavy Fog	+2	+2	+2	+2	+0	+0	+1 DE, P	+0	+0	+0
Light Fog	+1	+1	+1	+1	+0	+0	+0	+0	+0	+0
Hail										
Heavy Hail	+0	-1 C	-2 G (B)/-3 (CI)	-1 MP (A)	-1	-1	+1 DB/+2 Mi	+1	+2 (H/Wi/VT)	+1 (+3 A)
Light Hail	+0	-1 C	-1 G (B)/-2 (CI)	+0	-1	-1	+1 Mi	+0	+1 (Wi/VT)	+2 (A)
Light										
Dusk/Dawn	+0	+0	+0	+0	+0	+0	+1	+0	+0	+0
Full Moon Night/Glare	+1	+1	+1	+0	+0	+0	+2	+0	+0	+0
Moonless Night/Solar Flare <sup>28</sup>	+2	+2	+2	+0	+0	+0	+3/+1 PH	+1	+1	+1
Pitch Black <sup>28</sup>	+3	+3	+3	+0	+0	+0	+4/+2 PH	+2	+2	+2
Rain										
Gusting Rain	+0	+0	-1 G (B)/-2 (CI)	-1 MP (A)	+0	+0	+2 DB/+3 Mi	+2	+3 (H/Wi/VT)	+2 (+4 A)
Heavy Rainfall	+0	+0	+0	+0	+0	+0	+1	+1	+1	+1
Lightning Storm	+0	+0	-1 (CI)	+0	+0	+0	+1/+2 Mi	+0	+1 (Wi/VT)	+2 (A)
Light Rainfall	+0	+0	+0	+0	+0	+0	+1 (CI)	+0	+0	+0
Moderate Rainfall	+0	+0	+0	+0	+0	+0	+1	+0	+0	+0
Torrential Downpour	+0	+0	+0	+0	+0	+0	+2	+2	+2	+2
Snow										
Blizzard <sup>32</sup>	+0	-2 C	-3 G (B)/-4 (CI)	-1 MP (A)	-2	-2	+2 DB/+3 Mi	+1	+3 (H/Wi/VT)	+2 (+4 A)
Heavy Snowfall <sup>32</sup>	+0	+0	+0	+0	-2	-2	+1	+1	+1v	+1
Ice Storm <sup>33</sup>	+0	-3 C	-4 G (B)/-4 (CI)	+0	-3	-3	+1 Mi	+0	+1 (Wi/VT)	+2 (A)
Light Snowfall	+0	-1 C	-1 CI	+0	-1	-1	+1 (CI)	+0	+0	+0
Moderate Snowfall <sup>34</sup>	+0	-2 C	-2 CI	+0	-2	-2	+1	+0	+0	+0
Snow Flurries	+0	-2 C	-3 (CI)	+0	-2	-2	+1/+2 Mi	+0	+1 (Wi/VT)	+2 (A)
Sleet <sup>35</sup>	+0	-1 C	-2 (CI)	+0	-1	-1	+1/+2 Mi	+0	+1 (Wi/VT)	+2 (A)
Wind										
Light Gale	+0	+0	-1 G (CI)	+0	+0	+0	+0	+0	+0	+1 (A)
Moderate Gale	+0	+0	-1 (CI)	+0	+0	+0	+1 M	+0	+1 (Wi/VT)	+2 (A)
Strong Gale	+0	+0	-1 G (B)/-2 (CI)	-1 (A)	+0	+0	+1 DB/+2 Mi	+1	+2 (H/Wi/VT)	+1 (+3 A)
Storm	+0	+0	-1 G, no J (B); no CI	-1 SF	+0	+0	+2 DB/+3 Mi	+3	+3 (H/Wi/VT)	+2
Tornado F1-F3	-2 W	-2 C <sup>31</sup>	no I	-1 SF; no A	+0	+0	+2 DE, P/+3 DB/no Mi	+3	+3	+3
Tornado F4	W only	no C	no I	no A	+0	+0	+3 DE, P/no DB, Mi	+5	—	—
Misc.										
Blowing Sand	+0	+0	-1 (CI)	+0	+0	+0	+1 DE/P/+1 Mi	+0	+1 (Wi/VT)	+2 (A)
Extreme Temperatures	+0	+0	+0	+0	p. 62	+0	+0	+0	+0	+0

### Level 1 Foliage

In standard *Classic BattleTech* rules, woods rise two levels above the underlying terrain. Level 1 foliage allows players to designate woods and jungle hexes as rising only 1 level above the underlying terrain.

All other rules concerning woods, including their *Terrain Factor* (see p. 64), remain the same. They rise only 1 level, and so their interaction with various units and line of sight will change accordingly (see *Terrain Height and Depth*, p. 100, *TW*).

**Partial Cover:** Level 1 foliage never provides partial cover for 'Mechs.

**Chainsaw:** A chainsaw (see p. 134, *TW*) can reduce a Level 1 foliage hex from its current state to one lower in a single turn.

### Magma

Magma is divided into two different types of terrain: crust and liquid. Apply the modifiers shown on the Expanded Movement Costs and Planetary Conditions Table for movement into magma hexes.

**Crust:** Every time a unit enters a magma crust hex along the ground (hover, VTOL and WiGE vehicles do not count, nor do infantry expending VTOL MP), the controlling player rolls 1D6. On a result of 1-5, nothing occurs; on a result of 6, the crust breaks and the hex is immediately converted into a liquid magma hex of Depth 1 (it stays a liquid magma hex for the remainder of the scenario; see below).



INTRODUCTION

ADVANCED  
GROUND MOVEMENT

ADVANCED  
COMBAT

ADVANCED  
BUILDINGS

ADVANCED  
SUPPORT  
VEHICLES

GENERAL  
RULES

ADVANCED  
SUPPORT VEHICLE  
CONSTRUCTION

ADVANCED  
WEAPONS  
AND EQUIPMENT

INDEX

RECORD SHEETS



If a 'Mech or vehicle is expending Jumping MP and its target landing hex is a magma crust hex, on a result of 4, 5 or 6 the crust breaks and becomes a liquid magma hex.

For heat-tracking units, every magma crust hex they enter (but do not occupy it during the Heat Phase) generates 2 additional Heat Points in that turn; occupying a magma crust hex during the Heat Phase generates an additional 5 Heat Points that turn.

**Liquid Magma:** Any unit other than a 'Mech that enters a liquid magma hex is automatically destroyed. If a Hover, VTOL or WiGE vehicle—or infantry unit expending VTOL MP—touches the ground of such a hex for any reason (landing, damage and so on), that unit is automatically and utterly destroyed. In all instances, the unit cannot be salvaged in any way.

If a 'Mech jumps into a liquid magma hex (or into a magma crust hex that turns into a liquid magma hex), the controlling player must make a Piloting Skill Roll to determine if the 'Mech becomes stuck (see *Bog Down Rules*, p. 62).

'Mechs that start their Movement Phase in a liquid magma hex, or enter such a hex, take 2D6 points of damage to each exposed location immediately upon entering the hex. If the 'Mech is moving normally, its legs constitute its exposed locations; if the 'Mech falls, all of its locations (including front and rear torsos) are exposed. Make separate damage rolls for each location; regardless of how much damage is rolled, it is considered only a single attack. A unit that starts and ends a Movement Phase in a liquid magma hex takes an additional 2D6 of damage to its exposed locations; again, make a separate damage roll for each location, but this roll is considered a separate attack from the original 2D6 damage roll.

For 'Mechs, every liquid magma hex it enters (but does not occupy it during the Heat Phase) generate 5 additional Heat Points in that turn; occupying a liquid magma hex during the Heat Phase generates an additional 10 Heat Points that turn.

Unlike any other type of outside heat source (see p. 159, *TW*), there is no cap to the total heat that can be generated against a unit by magma. When determining heat from magma, a player should sum up all other outside heat sources for the unit and then apply the cap of 15 first, disregarding any heat above 15. Then apply the heat from magma, no matter how much heat it has generated.

**Non-Spheroid Aerospace Units:** If aerospace units are landing or taking off and enter a magma crust hex, apply the heat effects, but do not roll to see if the crust breaks. If such a unit enters a liquid magma hex, it is automatically destroyed and cannot be salvaged.



DK

*A volcanic vent begins to erupt as Roughrider warriors stand in awe of nature's fury.*

**Spheroid Aerospace Units:** A landing Spheroid aerospace unit (including units landing using VSTOL) automatically turns a magma crust hex into a liquid magma hex. If the unit is a single hex unit, it is automatically destroyed. If it is a multi-hex unit and all the hexes it lands in are magma, then it is automatically destroyed. If it is a multi-hex unit and only some hexes it occupies are turned to magma, then apply the 2D6 damage described above for each such hex to the aft location; each hex is considered a block of damage.

**Eruptions:** The large-scale eruption of a volcano would devastate almost any size of force unlucky enough to be within a "playing area" of such an event. Rules for such a scenario are simply beyond the scope of any in-game mechanics. However, players can use the following rules to simulate "micro" eruptions that can occur and have an effect on a playing area without wiping every trace of all forces off the map.

Before play begins, the players must determine how often they wish the eruptions to occur. If they want only a small chance of such an occurrence, then the players should nominate 12 as the target number; if players prefer a higher frequency, they should choose a Target Number of 8. Or, if the players are looking to "build up" to the point that an eruption is almost certain (as often occurs with volcanic activity), they can start at 12 and then lower that target number every turn or every other turn. Finally, players can also set an arbitrary turn in which a die roll determines when the eruptions will begin.

At the start of the turn that the playing group has determined is the first chance for an eruption to occur (whether this is the first turn of the game, Turn 5, Turn 10 or whatever they decided before play began), roll 2D6. If the result equals or exceeds the pre-determined target number, the eruption has begun; if the roll is less than the target number, the eruption has not yet begun and a roll against the appropriate target number is made at the start of the following turn.

During the first turn when the eruption starts, the player that won the Initiative selects one unoccupied hex (containing no units of any kind) on the playing area. He then rolls 2D6. On a result of 6 or more, that hex dissolves into magma. Any unit within a two-hex radius receives 10 points of damage, assigned in 5-point Damage Value groupings to the facing in the direction of the attack (double the damage against conventional infantry and apply it as though it were an attack from another infantry unit).

Additionally, in the target hex and six adjacent hexes (but never the second ring of twelve hexes), this damage is also applied vertically to the elevations above the target hex (meaning an airborne VTOL in a target hex that is at a low enough elevation may still take damage). In the target hex, for each subsequent elevation above the hex's underlying level, reduce the damage by 1 point and apply that damage to the next elevation; in the six adjacent hexes, reduce the damage by 2 and apply that damage to the next elevation (use the Front/Rear location, if a location is needed). In both instances, this is done until there is no more damage to apply to a higher elevation. Finally, such vertical damage is not inflicted twice against units that occupy more than one level (such as a standing 'Mech).

Use the rules for Buildings and Levels (Hills) as they interact with artillery when determining the outcome of an eruption's interaction with such terrain features (see p. 184).

Any units tracking heat receive an additional 2 Heat Points for that turn. Finally, any hex within the two-hex radius that can catch fire (woods/jungle, building and so on) is automatically set on fire as though attacked by infernos.

The player that lost Initiative may then select a hex and repeat the process.

For each additional turn the game continues after the eruption begins, each player may select another unoccupied hex and repeat the process described above.

Each hex that dissolves into magma takes on the properties of magma (see above) and ignores its previous terrain feature, though it retains its current height. However, unlike the magma rules above, in which the magma is considered stagnant, this magma is injected with the kinetic energy of its eruption. As such, if any hex adjacent to the newly erupted magma hex is lower than the magma hex, during the End Phase of the turn following the turn in which it erupted, the magma will flow into that hex; ignore the new hex's previous terrain feature and apply all magma rules. If multiple hexes qualify, randomly determine which hex the magma will enter (it will only flow into a single hex). Depending on the terrain of the playing area and where the eruptions occur, several magma rivers can eventually result from this "cascade."

If a 'Mech occupies a hex where lava enters in this fashion, the 'Mech must make an immediate Piloting Skill Roll to avoid falling.

If players are using the Terrain Factor rules (see p. 64), once the eruption starts, if the level of any hex is reduced due to damage, immediately roll 2D6; on a result of 5 or less, nothing occurs. On a result of 6 or higher, an eruption occurs in that hex.

Finally, while players can choose whether to add this complication or not, volcanoes are usually accompanied by earthquakes; incorporating an earthquake (see p. 55) with volcanic eruptions will make for a more realistic, and scary, scenario.

In the Eruption Diagram, Player A is fielding two 'Mechs, while his opponent keeps using a VTOL to harass him on the Large Mountain #1 map. The players have just determined through a successful die roll that an eruption is taking place, so Player A decides on a sneaky tactic. He nominates Hex A as a location for a potential eruption and rolls 2D6; the result of a 7 means a micro eruption occurs in that hex (and the hex is turned into magma). The VTOL in Hex A is at Elevation 14. As that is 4 hexes above the Level 10 of the underlying terrain, 4 points of damage are subtracted from the 10 that is applied in the two-hex radius shown in the diagram, leaving 6 points to be assigned in 5-point and 1-point Damage Value groupings to the Front column of the VTOL Hit Location Table.

However, Player A didn't think that move through well enough, and since his 'Mech in Hex B is within a two-hex radius of the eruption, the 'Mech takes 10 points of damage, assigned in two 5-point Damage Value groupings, to the Rear Location of the 'Mech Hit Location Table. Even though damage would be assigned to the elevations above the underlying Level 8 in Hex B, since damage was already assigned once to the 'Mech, no further damage is applied even though it occupies two levels of height.

Luckily for Player A, the Level 12 in Hex C is in the LOS between the erupting Hex A and his own 'Mech in Hex D. Hex C is higher than the underlying terrain of Hex D, and so it blocks any damage that would have been applied to the 'Mech in Hex D.

However, Player A is once again not playing smart. During the following turn, he doesn't move the 'Mech in Hex A. As an adjacent hex exists to the erupting magma hex, and the adjacent hex is at a lower level, the magma will flow into that hex. Hex B and Hex E are lower and adjacent, and so Player A randomly determines which hex the magma will flow into; as luck would have it, it will flow into Hex B! Player A must make an immediate Piloting Skill Roll. With a Piloting Skill Rating of 5 and no damage taken, he rolls and gets a result of 4; he's fallen!

Looking at the magma rules (because Hex B is now a magma hex), Player A knows that since the 'Mech in Hex B is going to start the Movement Phase of the next turn in a magma hex, and he's just fallen in that magma hex, his inattention has just inflicted 2D6 points of damage on every location on his 'Mech. If he doesn't manage to stand and move out of the hex, he'll take an additional 2D6 points of damage to every location on his 'Mech at the end of the same Movement Phase. Not to mention the extra heat during the Heat Phase...let's hope his dice are up for it!



• ERUPTION DIAGRAM •

### Planted Fields

Planted fields (crops of wheat, corn and so on) have no effect on movement modifiers. However, planted fields rise 1 level above the underlying terrain and impart a +1 to-hit modifier for every two full hexes of planted fields intervening between the attacker and target. A total of 6 intervening planted fields hexes blocks LOS.

In addition, apply a +1 to-hit modifier against any infantry in a planted fields hex; damage against conventional infantry in a planted field is still doubled.

**Combine:** A player with a unit mounting a combine can announce that he is activating the combine at the start of the turn; the combine is considered activated until the player announces he is deactivating it at the end of a turn. The unit may not expend Running/Cruising MP and must apply a +1 modifier to any Piloting Skill Rolls required during any turn when the combine is active. Addition-



ally, a +2 to-hit modifier is applied to any weapon or physical attacks made by the unit in a turn when the combine is active.

However, every planted field hex that the unit enters is automatically reduced to a clear hex. If there are any units (friendly or enemy) in a hex entered by a unit operating an active combine, roll 1D6 (the 1D6 roll is made for every friendly or enemy unit). On a result of 4, 5 or 6, the unit in question is “hit” by a combine physical weapon attack (see p. 146, *TW*); resolve all effects immediately before moving on (before the combine’s movement continues). This could result in numerous attacks occurring during a single combine unit’s movement.

**Landing Spheroid Units:** Any planted field hex adjacent to the landing hex(es) of a Spheroid aerospace unit might catch fire (see p. 43). Roll 2D6 and apply all appropriate modifiers from the Fire Table, such as planetary conditions. If the result is 7 or less, the hex is on fire.

*A ‘Mech and infantry unit are firing at a target vehicle 3 hexes away that is in a planted field hex, while both hexes along the LOS are planted fields. The ‘Mech ignores the first planted field hex, but the vehicle is adjacent to a planted field so the ‘Mech must take into consideration that adjacent planted field hex and the planted field hex the vehicle occupies, so applies a +1 to-hit modifier. Meanwhile the infantry, at Level 1, draws LOS through the two intervening hexes. However, as that only equals a total of 3 planted fields hexes (including the hex the vehicle occupies), only a +1 to-hit modifier is applied.*

### Rough (Ultra)

Ultra-rough terrain represents a variety of truly shattered landscapes, including ultra woods/jungle hexes that have been reduced to rough ground.

Apply the modifiers shown on the Expanded Movement Costs and Planetary Conditions Table for movement into an ultra-rough hex.

### Rubble (Ultra)

Ultra-rubble represents destroyed buildings made of the hardest, military-spec materials, making such a hex exceptionally difficult to navigate. Destroyed Castles Brian and fortress hexes are turned into ultra-rubble hexes.

Apply the modifiers shown on the Expanded Movement Costs and Planetary Conditions Table for movement into rubble hexes. In addition, a Piloting Skill Roll with a +1 modifier is required upon entering an ultra-rubble hex.

### Sand

The Expanded Movement Costs and Planetary Conditions Table lists two MP costs for sand. The 1 MP cost applies to all units except infantry and Wheeled Vehicles; the 2 MP cost applies to infantry units and Wheeled Vehicles (except in the case of a Wheeled Support Vehicle that mounts the Dune Buggy Chassis and Controls modification). Infantry can avoid the increased MP cost by using Jumping MP, however.

Large Vehicles without the Dune Buggy Chassis and Controls modification entering a sand hex may get stuck (see *Bog Down Rules*, p. 62).

Apply a +1 modifier to all Piloting/Driving Skill Rolls made in a sand hex.

### Sheer Cliffs

In standard *Classic BattleTech* rules, all changes of Level 1 or Level 2 from one hex to an adjacent hex are considered to have enough of a slope to allow for appropriate units to move across them with little problem. This is not always the case, however, as some terrain—even if its height is not very significant—is difficult to cross due to a sheer vertical drop.

Unlike other terrain conditions, which change the entire hex, sheer cliffs only change designated hexsides. Before play begins, players determine which hexsides they wish to make sheer. Such hexsides can only be nominated if two adjacent hexes are of a different level. Though MP costs must still be taken into account when dealing with differences between a Level 1 change and a Level 2 change between two hexes, for the purpose of the rules for sheer cliffs as noted below, Level 1 and Level 2 cliffs are the same.

No units may use backward movement across a sheer cliff hexside (see *Backward Movement (Expanded)*, p. 22).

#### Moving from a lower level to a higher level across a sheer cliff hexside:

- **Mechs:** ‘Mechs must make a Piloting Skill Roll when using ground movement to cross a sheer cliff hexside (+1 if a Level 1 sheer cliff, +2 if a Level 2 sheer cliff); a failed Piloting Skill Roll does not result in a fall in this case, but it means the attempt to cross the hexside has failed. The ‘Mech remains in the hex where it started to cross the hexside, and the MP expenditure to cross that hexside and enter the hex has been lost. If the ‘Mech has sufficient MP remaining, it can attempt to cross the hexside again. A ‘Mech cannot use a Climbing action to cross a Level 1 or Level 2 sheer cliff (see *Climbing*, p. 22).
- **Vehicles:** With the exception of VTOLs and WiGEs, vehicles are prohibited from crossing a sheer cliff (though WiGE Vehicles must expend an extra 1 MP to cross a sheer cliff if they are moving at their standard 1 level above the underlying terrain).
- **Infantry:** Infantry cannot cross a sheer cliff using ground movement unless they use a Climbing action (see *Climbing*, p. 27). Mountain troops (see p. 341), however, can cross a Level 1 sheer cliff side, with no additional movement cost (to cross a Level 2 or higher sheer cliff, they must use a Climbing action).

#### Moving from a higher level to a lower level across a sheer cliff hexside:

- **‘Mechs:** ‘Mechs must make a Piloting Skill Roll when using ground movement to cross a sheer cliff hexside (+0 if a Level 1 sheer cliff, +1 if a Level 2 sheer cliff); a failed Piloting Skill Roll means the ‘Mech has fallen into the hex it was attempting to enter and its movement is over (assign damage for the fall per standard rules).
- **Vehicles:** Vehicles—except VTOL and WiGE—must make a Driving Skill Roll to cross a Sheer Cliff hexside. A failed roll forces an automatic roll on the vehicle’s Motive System Damage table and its move is over.
- **Infantry:** Infantry cannot cross a sheer cliff hexside using ground movement unless they use a Climbing action (see *Climbing*, p. 27); mountain troops (see p. 341), however, can cross a Level 1 sheer cliff side, with no additional movement cost (to cross a Level 2 or higher sheer cliff, they must use a Climbing action).

INTRODUCTION

ADVANCED  
GROUND MOVEMENT

ADVANCED  
COMBAT

ADVANCED  
BUILDINGS

ADVANCED  
SUPPORT  
VEHICLES

GENERAL  
RULES

ADVANCED  
SUPPORT VEHICLE  
CONSTRUCTION

ADVANCED  
WEAPONS  
AND EQUIPMENT

INDEX

RECORD SHEETS



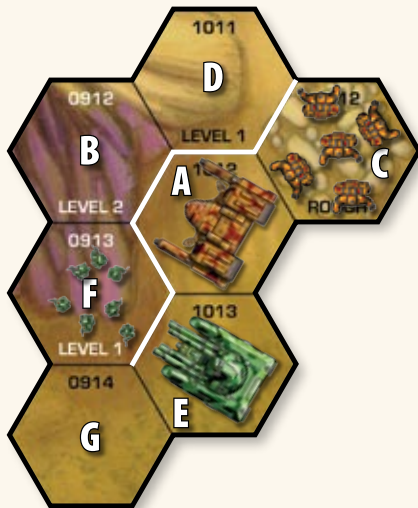

• SHEER CLIFF DIAGRAM •

In the Sheer Cliff Diagram, a series of units are attempting to scale sheer cliffs on the BattleForce map; prior to the start of play, the players designated the white-lined hexsides as sheer cliffs.

The 'Mech in Hex A has a Movement of 5/8 and a Piloting Skill Rating of 4. It must expend the standard 3 MP to enter Hex B. However, because it is a Level 2 sheer cliff, the controlling player must make a Piloting Skill Roll with a +2 modifier. The controlling player declares that the 'Mech is running and makes his Piloting Skill Roll. The result of 5 means a failure. This does not result in a fall (if the player had been moving his 'Mech from Hex B to Hex A, a failed Piloting Skill Roll would have resulted in a fall in Hex A), but the 3 MP are lost. If the player had not nominated the 'Mech for running, he would not be able to move into Hex B this turn. The player once again makes a Piloting Skill Roll with the +2 modifier; this time, he gets a result of 7, meaning the 'Mech has scaled the sheer cliff. The player has expended 6 MP to do so and so only has 2 more MP remaining to finish the 'Mech's move.

The battle armor in Hex C must use a Climbing action to cross the sheer cliff hexside into Hex D. Checking the Climbing rules, the controlling player notes that since his battle armor troops are swarm capable, it only costs 1 MP to move across the sheer hexside and then another 1 MP to enter Hex B itself. The player can choose to either spend the 2 Ground MP, or just spend 1 Jumping MP.

The Vehicle in Hex E has a Movement of 6/9 and a Driving Skill Rating of 5. However, it cannot cross the sheer cliffside into Hex F because a vehicle cannot cross a higher-level sheer cliff hexside. Instead, the player would need to spend 7 MP to enter Hex F [1 (left facing change) + 1 (entering Hex G) + 2 (two right facing changes) + 3 (changing 1 level and entering Hex F) = 7]. Next turn, if the player chose to move into Hex E, he could spend 4 MP [1 (right facing change) + 3 (changing 1 level and entering Hex E) = 4], but would need to make a Driving Skill Roll; a failed roll would result in an automatic roll on the Motive System Damage Table.

Finally, the conventional infantry in Hex F have 1 Ground MP and are not mountain troops. The only way they can cross the sheer cliff is through a Climbing action. While a Climbing

action requires 2 MP per level, the controlling player can use the Minimum Movement rule to make it work. So in the current turn, the controlling player moves the infantry to the sheer cliff hexside between hexes F and E, where they will remain until the following turn's Movement Phase. At that point, the controlling player will be able to move them into Hex E.

### Tundra

The Expanded Movement Costs and Planetary Conditions Tables lists the MP costs for tundra. Additionally, a unit entering a tundra hex may get stuck (see *Bog Down Rules*, p. 62).

### Woods (Ultra-Heavy)

The Expanded Movement Costs and Planetary Conditions Table lists the MP costs and other modifiers for ultra-heavy woods, as well as which units are prohibited from entering them.

For purposes of determining line of sight, ultra-heavy woods rise 3 levels above the underlying terrain. A single ultra-heavy woods hex lying between an attacking unit and its prospective target will block line of sight. Attacks against a target that occupies an ultra-heavy woods hex suffer a +3 to-hit modifier.

**Clearing Woods:** When clearing woods (see p. 112, *TW*), when ultra-heavy woods are reduced to heavy woods, they are converted to heavy woods, effectively reducing the height of the hex's trees to 2 levels above the underlying terrain (for more details, see *Terrain Factor Rules*, p. 64).

### TERRAIN MODIFICATIONS

Terrain modifications represent additions to a given hex's base terrain type caused by weather, specific geologic conditions or human intervention.

As noted previously, modifiers and unit prohibitions imposed by terrain modifications are added to modifiers and unit prohibitions imposed by the underlying base terrain type.

In addition, units moving into a hex containing terrain modifications may be subject to bogging down (see p. 62). Though all such terrain modifications should be clearly marked before a given scenario begins, if no underlying base terrain type is specified for a particular hex, assume the underlying terrain is clear.

Roads/bridges and rubble are now classified as terrain modifications. Rules for these conditions appear under *Movement on Pavement*, p. 61, *TW*.

The following entries describe rules for various terrain modifications.

### Black Ice

Unlike ice (see p. 50), which is usually pre-designated, black ice can suddenly "appear" on pavement. During any movement that occurs on pavement (including bridges) where the Black Ice terrain modification is in use, apply the following rules.

Whenever a 'Mech or non-hover vehicle enters any paved hex, immediately roll 1D6. On a result of 5 or 6, ice has formed in that hex; all rules that apply to ice (see p. 50) are immediately applied, as appropriate, to that hex.

### Bug Storms

The so-called bug storm is an unusual event—but not a wholly uncommon one—in which enormous swarms of local flying insects, insect analogues or very tiny avian life forms fill the skies with a mad press of bodies.



## BUG STORM TYPE TABLE

Roll	Storm Type	Effects*
1-2	Localized	Randomly place 1D6 bug storms (1 hex wide) for every two mapsheets used. Multiple storms may not occupy the same hex, and remain stationary.
3-5	Transient	Randomly place 1D6 bug storms (1 central hex and all adjacent hexes) for every mapsheet used. Multiple storms may not share the same center hex. During the End Phase of each turn, each bug storm will move 1 hex in a random direction.
6	Mass Migration	A continuous mass storm 2D6 hexes wide extends across the map, centered on a random starting point and moving toward the opposite side (if any wind conditions are in use, the starting point must be determined in a fashion that extends the storm across the field in the direction of the prevailing wind; see Wind Direction, p. 57). Roll again to determine the nature of any secondary bug storms. If another Mass Migration results, the entire map is covered by a bug storm.

\*If a wind condition is in use (see p. 57), apply the following rules to determine bug drift, in the direction of the prevailing wind: Light Gale = 1 hex; Moderate Gale = 2 hexes; Heavy Gale = 3 hexes; Storm = 4 hexes. Bug storms cannot be used in the same game with Tornado F1–F3 or Tornado F4+ wind conditions.

If a scenario takes place under such conditions, modify movement and combat as follows.

Bug storms are abstracted into three main varieties: Localized (where small, globular clusters of insectoids generally mill about in somewhat stationary 30-meter areas), Transient (where larger clusters move about in a relentless search for food or such) and Mass Migrations (which can blanket entire strips of land as the creatures move in a mind-numbing mass).

If players opt to simulate a bug storm in their games, the type of bug storm that occurs may be randomly determined by rolling 1D6 and consulting the Bug Storm Type Table (above), which will determine the shape and general nature of the storm as it should appear on the playing area. In addition, the players should determine if the bugs are particularly hostile or voracious—and will thus eagerly attack other creatures in the storm area. This can be determined by the gamemaster or player agreement, or by a 2D6 roll result of 10+ prior to the start of play.

Bug storms extend up to four levels above the underlying terrain in every hex covered by the storm, representing the area that is considered filled with a swirling mass of tiny, flying creatures.

All non-energy ranged weapons that fire into or through a bug storm hex suffer a +1 to-hit modifier (regardless of the number of hexes), while all energy weapons suffer a +2 to-hit modifier. Furthermore, conventional infantry units, exoskeletons without a Clan chassis weight, extended life-support, or a minimum of 1 point of armor, and Support Vehicles that feature either an open convertible top or a pillion seat must spend 1 extra MP per bug storm hex entered.

If the creatures are hostile or voracious, make a 2D6 roll against the same unit types slowed down by bug storm effects for every bug storm hex entered. On a result of 11 or 12, the bugs inflict damage to these units based on their type. Conventional infantry lose 1D6 troopers to damage from the storm (apply the damage as though the attack originated from another infantry unit), while susceptible exoskeletons lose 1 trooper from the storm. Susceptible Support Vehicles

must make another 1D6 roll, suffering a Driver Hit on a result of 1-3, a Gunner Hit on 4-5, or a Crew Stunned on 6, re-rolling any result that does not apply. If the Support Vehicle has already lost both its driver and gunner and its crew is stunned, any additional damage from the storm kills the Support Vehicle's crew.

### Deep Snow

If a scenario uses deep snow, apply the following rules.

**All Units:** Apply a +1 MP cost per hex (unless the vehicle mounts the Snowmobile Chassis and Controls modification) and a +1 modifier to all Piloting/Driving Skill Rolls; additionally, units entering deep snow may get stuck (see *Bog Down Rules*, p. 62).

**Fire:** If a fire starts in a hex that includes deep snow, after three turns during the End Phase the deep snow is reduced to mud.

**Heat:** Apply –1 Heat Point per turn; for 'Mechs, this modifier only applies if a heat sink is mounted in the legs (if the 'Mech is prone, a maximum of –3 extra Heat Points per turn are dissipated).

**Weapons Fire:** If a flamer, incendiary LRMs or plasma weapon is used on a deep snow hex to try to start a fire (see p. 43), roll 2D6. On a result of 12, the Deep Snow terrain modification is reduced to mud; no fire is started. Any weapons fire that strikes the hex due to a missed shot (see p. 81) is ignored. However, if missile infernos, inferno fuel ammo, inferno-IV artillery or inferno bombs hit a target hex (whether intentionally or not), the deep snow is automatically reduced to mud; as above, no fire is started.

**Spheroid Units:** A landing Spheroid unit automatically converts any deep snow hexes where it lands into that hex's underlying terrain; clear, rough and so on.

**Note:** Unless the underlying terrain is specified in the scenario rules, the players may agree to treat the underlying terrain of deep snow as Ice (see p. 50) or Clear terrain.

**Prohibited Conditions:** Cannot be used with Vacuum Atmospheric Pressures, or with Extreme Temperatures of 30 degrees Celsius and above.

INTRODUCTION

ADVANCED  
GROUND MOVEMENT

ADVANCED  
COMBAT

ADVANCED  
BUILDINGS

ADVANCED  
SUPPORT  
VEHICLES

GENERAL  
RULES

ADVANCED  
SUPPORT VEHICLE  
CONSTRUCTION

ADVANCED  
WEAPONS  
AND EQUIPMENT

INDEX

RECORD SHEETS



## EXTREME DEPTH TABLE

Depth	Modifiers (BattleMechs/ProtoMechs/Battle Armor/Submarines)					
	Walk/Cruise Modifier	Weapon Attack MP Modifier	Physical Attack Modifier*	BattleMech Piloting Modifier	BattleMech Heat Modifier	Hull Breach TN
15 or less	+3/+3/+0/+0	+0/+0/+0/+0	+0/+0/+0/+0	+1	-1†	10/10/10/10
16–20‡	+4/+4/+0/+0	+1/+1/+0/+0	+1/+1/+0/+0	+2	-6	10/10/10/10
21–25	+5/+5/+1/+0	+2/+2/+1/+0	+2/+3/+1/+0	+3	-7	9/9/10/10
26–30	+6/+6/+2/+0	+3/+3/+2/+0	+3/NA/+2/+0	+4	-9	9/9/10/10
31–35§	+7/+7/+2/+0	+4/+4/+3/+0	+5/NA/+3/+0	+5	-12	8/8/10/9
36–50	+9/+9/+3/+0	+6/+6/+4/+0	NA/NA/+5/+0	+7	-15	8/8/9/9
51–150¶¶	-/-/+4/+0	-/-/+6/+0	-/-/NA/+0	—	—	-/-/8/9
151 or more	-/-/-/+0	-/-/-/+0	-/-/-/+0	—	—	-/-/-/8

\*Applies to anti-Mech attacks by battle armor as well as ProtoMech “frenzy” and submarine “ramming” attacks.

†Per submerged heat sink (to a maximum of -6)

‡Mechs and ProtoMechs make Crush Depth Checks for each hex entered below a Depth of 15.

§Battle armor make Crush Depth Checks for each hex entered below a Depth of 30.

¶¶Submarine units make Crush Depth Checks for each hex entered below a Depth of 50.

### CRUSH DEPTH CHECKS (2D6)

*Base: See appropriate Hull Breach TNs above. Apply the following TN modifiers by unit type:*

BattleMechs: +1 for every ten (full) tons of BattleMech weight, -1 for every depth higher than 15.

ProtoMechs: +1 for every ton of ProtoMech weight, -1 for every depth higher than 15.

Battle Armor: +(battlesuit’s current armor value), -1 for every 2 full depths higher than 30.

Submarines (300 tons and under): +1 for every 5 tons of submarine weight, -1 for every 5 depths higher than 50.

Submarines (over 300 tons): +60, -1 for every 5,000 tons of submarine weight, -1 for every 5 depths higher than 50.

### Extreme Depths

Though it is true that BattleMechs, certain battle armor designs and submarines are fully sealed combat systems capable of fighting underwater, the rules given in *TW* presuppose that such units engage in battle close to a shoreline, where depths rarely exceed 90 meters (15 depths). However, in some exceedingly rare instances, these battlefield units—by accident or design—may be required to enter extreme depths, at which point such factors as hull pressure become a dramatically increasing problem, especially for BattleMechs, ProtoMechs and battle armor. Additionally, extreme depths can have a significantly different impact on various units.

The Extreme Depth Table above summarizes the effects of entering each depth for all relevant units. Units not on the list are automatically destroyed upon submerging in Depth 1+ water. The effects include Walking/Cruising MP penalties, weapon attack penalties, physical attack penalties, heat level bonuses and Hull Breach target numbers (which are used to determine the chance of hull breach from attack damage as well as the likelihood of a hull breach due to crushing pressures). All figures given are for BattleMechs, ProtoMechs, UMU-equipped battle armor and submarines, respectively. An NA entry means the action is not allowed, while a dashed entry means the unit is automatically destroyed at that depth. The listed modifiers include those already covered by the Underwater Movement (Non-Naval Units) and combat underwater rules in *TW* (see pp. 56 and 109, respectively), which take effect at depths of 15 or less.



*A MechWarrior eludes hostile Chaos March mercenaries patrolling on the surface far above.*

DK



At crush depths (15 or more for BattleMechs or ProtoMechs, 30 or more for battle armor, 50 or more for submarines), the affected unit must immediately make a Crush Depth Check using the base Hull Breach target number (TN) for every hex entered while below crush depth. This roll is modified as indicated on the table for unit size and depths below crush depth. If the roll result equals or exceeds the modified TN for that depth, the unit suffers a catastrophic hull breach caused by extreme pressure. ProtoMechs, battle armor and submarines are instantly destroyed once they fail one of these checks. BattleMechs must roll for a random location (based on the Front/Back Hit Location Table) and suffer all the effects of a hull breach to that location as described on page 121, *TW*. Remember that any checks for hull breach due to damage from attacks, falls or collisions use the base Hull Breach TNs without the crush depth modifiers.

**IndustrialMechs:** IndustrialMechs are destroyed if they enter an Extreme Depth hex, unless they are equipped with a fuel cell, fission or fusion power plant and they mount the Environmental Sealing Chassis and Controls modification. In that case they are treated as BattleMechs for purposes of these rules.

**High/Low Gravity:** The Extreme Depth Table applies only under terrestrial conditions. To reflect conditions where the gravity effects are greater or lesser than Terra-standard, assign a gravity rating to the scenario per the High/Low Gravity rules (see p. 55), then divide the maximum depth per range and the crush depth given on the table by the local gravity. Adjust the minimum depths per range accordingly, and apply modifiers and Hull Breach Checks only as the appropriate units reach the depths indicated under their new depth ranges.

For example, on a 0.5-G world, each maximum depth per range would be divided by 0.5, meaning a BattleMech would operate per the normal *TW* rules up to a maximum depth of 30 [ $15 / 0.5 = 30$ ], would make Crush Depth Checks only after dropping below a Depth of 30, and would suffer a +4 MP penalty, +1 attack penalty, +2 piloting penalty, and receive -6 heat points per turn when operating at depths 31 through 40 [ $20 / 0.5 = 40$ , minimum of 31 determined based on 30 maximum from previous depth range].

## Fire

While not exactly a terrain modification in the same vein as the other rules that appear in this section, fire can affect a unit's movement, to-hit modifiers and so on. Additionally, because fire is applied and tracked on a hex-by-hex basis (albeit usually across the duration of a game), it is most appropriately covered here.

Players may use the following rules to simulate the effects of fire. Place a fire counter (a pre-made counter, a penny or whatever else works for a playing group) on any hex that is set on fire during the game. Once started, a fire continues to burn for the rest of the game (see *Putting Out Fires*, p. 45).

**Buildings:** For each turn that a building is on fire, it loses 2 CF (regardless of the size or type of building). If a 'Mech moves through a burning building, it suffers normal heat buildup from fire as well as all other normal damage.

If using the expanded Construction Factor rules (see p. 121), the fire should be tracked per level in the hex, applying 2 CF to each level on fire.

- **Accidental Fires:** Weapons powerful enough to smash a 'Mech with one blow may also create extensive collateral damage, the most devastating of which is fire. Players may use the following rules to represent accidental fires.

A unit attempting to clear a wooded/jungle hex (see *Clearing Woods*, p. 112, *TW*; also see *Terrain Factor*, p. 64) runs the risk of setting the woods on fire accidentally. To represent this risk, the player rolls 2D6 before each clearing attempt. On a result of 5 or less, the woods have been accidentally set alight as well as taken damage.

If a weapon attack against a unit occupying a wooded/jungle hex misses its target, and the weapon can be used to start fires (see *Intentional Fires*, below), the attacking player rolls 2D6 to determine whether his attack accidentally set a fire. On a result of 2 or 3, the player should make another roll as though he were intentionally setting the hex on fire, applying all appropriate modifiers, as well as an additional +2 modifier; if the roll is a success, the hex has been set on fire. A building cannot be accidentally set on fire.

If using the Missed Shots rule (see p. 81), players can decide if they wish to roll for every wooded/jungle hex a missed shot enters, or just the hex of the original target. This is per unit, per turn. If a player decides that he wishes to roll for every wooded/jungle hex a missed shot enters, all missed shot attacks that turn from that unit must roll for all wooded/jungle hexes they enter.

- **Intentional Fires:** Players who intend to start fires may declare that their unit will fire its weapons at any woods/jungle/building hex. Modify the base to-hit number by -4 for an immobile target for this attack, as well as for the attacker's normal movement and other appropriate modifiers. On a successful attack, the player rolls 2D6 and consults the Fire Table to determine if the attack started a fire, applying all appropriate modifiers based on the weapon used and any planetary conditions that may be in use, or the type of building hex. If the attack starts a fire, place a fire counter on the target hex. Multiple successful attempts to start a fire do not make the fire larger.

**Infantry:** Standard infantry weapons, with the exception of flamers, and any other weapons that have a "Flame-Based" special feature (see pp. 148-149, *TM*), cannot be used to start a fire.

**Effects of Fire:** During the Heat Phase, a 'Mech (or any other heat-tracking unit) occupying a burning hex on the ground absorbs an additional 5 Heat Points. A 'Mech (or any other heat-tracking unit) also absorbs 2 Heat Points for each burning hex that it moved out of along the ground during the Movement Phase. A unit occupying a hex ignited during the Weapon Attack Phase of the turn will not be affected by the fire until the Heat Phase of the following turn.

The controlling player must make a roll each time any of the following conditions are met.

- **ProtoMechs:** Any time a ProtoMech ends its Movement Phase on the ground in a burning hex or moves along the ground into a burning hex, the controlling player must get a result of 8 or higher on a 2D6 roll. If the roll fails, roll once on the ProtoMech Hit Location Table; note that a near-miss result is still a near miss, and so the fire would have no effect. That location is destroyed; automatically mark off the shaded box furthest to the right in that location on the Hit Locations and Critical Hits section of the record sheet.

INTRODUCTION

ADVANCED  
GROUND MOVEMENT

ADVANCED  
COMBAT

ADVANCED  
BUILDINGS

ADVANCED  
SUPPORT  
VEHICLES

GENERAL  
RULES

ADVANCED  
SUPPORT VEHICLE  
CONSTRUCTION

ADVANCED  
WEAPONS  
AND EQUIPMENT

INDEX

RECORD SHEETS



## FIRE TABLES

### STARTING FIRES TABLES

Weapon Type	Success Number*
Flamer	4+
Incendiary LRMs	5+
Direct-Fire Energy or Pulse Weapon†	7+
Missile or Direct-Fire Ballistic‡	9+
Plasma Weapon and Inferno††	Automatic§

Terrain	Modifiers*
Planted Fields	-1
Woods	+0
Jungle	+1
Deep Snow	+2
Buildings	
Hangar	
Light	-2
Medium	-1
Heavy	+0
Hardened	+1
Standard/Wall	
Light	0
Medium	+1
Heavy	+2

### SPREADING FIRES TABLE

Situation	Success Number*
Crossing non-burning hex	+3
No Wind**	
Hex is downwind	9+
Hex is 60° from downwind	11+
Light and Moderate Gale	
Hex is downwind	7+
Hex is 60° from downwind	10+
Heavy Gale and Storm	
Hex is downwind	6+
Hex is 60° from downwind	9+

Terrain	Modifiers*
Hardened	+3
Fortress	
Medium	+2
Heavy	+3
Hardened	+4
Castles Brian	
Heavy	+5
Hardened	+6
Building Hex Mounts Armor	Additional +3
Heavy Industrial Zone	+2
Vacuum and Trace Atmospheric Pressure	No Fire
Weather	
Light and Moderate Rainfall	+1
Heavy Rainfall and Torrential Downpour	+2
Light and Moderate Snowfall	+2
Heavy Snowfall and Light/Heavy Hail	+3
Light and Moderate Gale	+2
Heavy Gale, Storm and Ice Storm	+4
Tornado F1-F3 and Tornado F4+	No Fire
Extreme Temperatures	**
Other Terrain	Fire cannot start or spread

\*All modifiers are cumulative

\*\*For every 10 degrees above 30 degrees Celsius, apply a -1 modifier. For every 10 degrees below -30 degrees Celsius, apply a +1 modifier

†May not use small laser or ER small laser, or any kind of micro laser.

††Includes missile infernos, inferno fuel ammo, inferno-IV artillery, inferno bombs, and incendiary grenades.

‡May not use any type of Gauss rifle, SRM-2 or conventional SRM infantry.

\*\*Roll 1D6 to randomly determine the "down wind" direction each time.

§Except under the following conditions: in Vacuum and Trace Atmospheric Pressures and in Tornado F1-F3 and Tornado F4+, no fire is possible. For Castles Brian hexes, fire is not automatic; instead, divide the standard Heavy and Hardened modifiers in half (round down) and apply a +2 modifier when making the roll to start a fire.

- Vehicles:** Any time a vehicle ends its Movement Phase on the ground in a burning hex or moves along the ground into a burning hex (this includes Hover Vehicles, but not WiGE Vehicles; VTOL and WiGE vehicles must land in the hex for these rules to apply), the controlling player must get an 8 or higher on a 2D6 roll. If the roll fails, the controlling player must automatically roll on the Front/Rear column of the appropriate unit's Critical Hits Table (see *Ground Combat Vehicle Critical Hit Effects*, p. 193, *TW*), with the following modifiers to the dice roll result: -2 for Combat Vehicles; no modifier for Support Vehicles (unless the Support Vehicle has the Armor

Chassis and Controls modification and a BAR of 10, in which case it is treated as a Combat Vehicle).

- Multi-Hex Support Vehicles:** Multi-hex units—Large Naval Vessels, Rail Trains and landed Airships—are as vulnerable to fire as other vehicles, but each hex of such units is treated separately in terms of damage and critical effects. When a multi-hex unit enters a burning hex (or begins a turn in one), the unit suffers 1D6 points of damage to the appropriate facing (or, if the hex is a center-line one, to either the left or right sides, or turret, if present—determined randomly). If the unit is the target of an inferno attack, then the hex of



the unit that takes the hit burns for the required number of turns, and the unit receives 1D6 damage during each End Phase. As with standard damage, damage from fire may inflict penetrating critical hits if the damage rolled exceeds the Support Vehicle's BAR. Damage from fire that hits the unit's internal structure also applies critical hits as normal. Fire on multi-hex Support Vehicles may spread per the standard rules for fire, treating each hex of the Support Vehicle as a Heavy Building for the roll modifier. However, in contrast to the standard spreading fire rules, fires on multi-hex Support Vehicles only spread in the direction of the prevailing winds if the multi-hex Support Vehicle is stationary at the time. If the unit is in motion, "downwind" is considered to be in the direction opposite the unit's travel (toward the rear of a forward-moving multi-hex Support Vehicle, or toward the front of a multi-hex Support Vehicle moving in reverse). Note that fires on multi-hex Support Vehicles may not skip hexes, unlike normal spreading fires. These rules only apply to external fires; internal fires use their own rules (see p. 190).

- **Mobile Structures:** If a Mobile Structure ends its movement in a hex on fire, roll 2D6. On a result of 12 or better, that Mobile Structure catches fire. If it catches fire, treat it as a building hex.
- **DropShips:** Fire has no effect on DropShips.
- **All Other Units:** Unless the controlling player gets an 8 or higher on a 2D6 roll, any unit that ends its Movement Phase on the ground in a burning hex or moves along the ground into a burning hex is destroyed. If a unit mounts fire resistant armor, fire has no effect on the unit (see *Fire Resistant Armor*, p. 223, TW).

**Spreading Fires:** Fires on the battlefield can spread from hex to hex in the direction of the wind through woods/jungle and building hexes, but they cannot spread into other terrain.

- **Determining Spread:** When a fire is started, a check for spread is first made during the End Phase of the following turn. During the End Phase of every turn, check to see if any fires currently on the map spread to additional hexes (note that wind direction must be determined to use this rule; see *Wind*, p. 57). Roll 2D6 for the adjacent hex directly downwind of a fire hex. If the result is equal to or greater than 9, and if that hex can burn (see the Fire Table, p. 44), and is within 4 levels of the burning material in the original hex (the levels of the burning woods, building and so on are taken into consideration when determining if an adjacent hex's level is "close enough" to catch fire), the fire spreads into the hex. Also roll 2D6 for each of the two hexes adjacent to the burning hex at 60 degrees from downwind (the remaining two hexes in the fire's "forward arc"). If the result is equal to or greater than 11, and if the hex can burn, the fire will spread into that hex as well. A flammable hex directly downwind from a fire but separated from it by a non-burning hex may also catch fire, provided there is no terrain higher than the terrain that is on fire, as well as the terrain in the target hex (in which case the chance to set that hex on fire is blocked). Apply a +3 modifier to the Target Number 9 for the adjacent hex directly downwind; if the die roll result equals 12 (9 + 3), the fire spreads to a flammable hex directly downwind from a fire. If one hex may catch

fire because of its relationship to several burning hexes, roll for each possibility. Finally, the target numbers noted above may change depending on the type of wind conditions in use (see the Fire Table, p. 44).

- **Expanded Construction Factor:** If using the expanded Construction Factor rules (see p. 121), when determining if a fire spreads beyond its current level in the same multi-hex building, a fire will automatically ignite the level directly above the level on fire during the End Phase. Additionally, for the level directly below a fire, as well as every level adjacent to the hex on fire, roll 2D6 and apply the appropriate building modifier from the Fire Table to the die roll result. If the result is 9 or less, that level is now on fire as well.
- **Putting Out Fires:** A fire will continue to burn for the rest of the game unless it is extinguished. The following rules cover how to extinguish a fire. All modifiers are cumulative.
  - **Terrain Factor:** If using the Terrain Factor rules (see p. 64), if all terrain conditions in a hex reach 0, then there is nothing left in the hex to burn and the fire will go out during the End Phase of that turn. For example, if a fire in a woods hex reduces the wood's Terrain Factor to 0, during the End Phase of that turn, the fire in that hex is extinguished.
  - **Area-Effect Weapons:** If 40 or more points of damage from area-effect weapons are dealt to a hex that is on fire in a single phase, the fire is extinguished.
  - **Sprayers:** If a unit mounts a sprayer (see p. 249, TM), directly targets a fire hex and hits it, the controlling player rolls 2D6; on a result of 8+, the fire is extinguished. For every sprayer that successfully strikes the target in the same Weapon Attack Phase, the controlling players may make a separate roll for each successful attack, or apply a -1 modifier for each additional sprayer to a single roll. If using the expanded Construction Factor rules (see p. 121), the extinguishing of a fire in this manner only applies to a targeted level within the building hex on fire.
  - **Infantry:** The controlling player may nominate a platoon (or battle armor squad) of infantry to fight the fire; the infantry must be in an adjacent hex and cannot have taken any other actions that turn (it cannot have moved or made any attacks). During the End Phase of a turn, the controlling player rolls 2D6; on a result of 10+, the fire is extinguished. For each additional active platoon/squad fighting the fire, the controlling player may make a separate roll for each successful attack, or apply a -1 modifier for each additional active platoon/squad to a single roll. If using the expanded Construction Factor rules (see p. 121), the extinguishing of a fire in this manner only applies to a targeted level within the building hex on fire.
  - **Weather:** Depending on the conditions in use, weather can extinguish a fire. Roll 2D6 for each fire hex on the board during the End Phase of each turn (after fire spreading is determined). If any of the following weather is in use, for light hail, light snowfall and light rainfall, add 1 to the roll result; in moderate snowfall, moderate rainfall and heavy hail, add 2; in heavy rainfall or heavy snowfall, add 3; in torrential downpour, add 4. If the final modified result is 11 or greater, the fire is extinguished.
- **Smoke:** During every End Phase (including the End Phase when the fire was started), for as long as a fire is alight, it

INTRODUCTION

ADVANCED  
GROUND MOVEMENT

ADVANCED  
COMBAT

ADVANCED  
BUILDINGS

ADVANCED  
SUPPORT  
VEHICLES

GENERAL  
RULES

ADVANCED  
SUPPORT VEHICLE  
CONSTRUCTION

ADVANCED  
WEAPONS  
AND EQUIPMENT

INDEX

RECORD SHEETS



spreads smoke (see *Smoke*, p. 47) to the adjacent hex downwind and to the two adjacent hexes 60 degrees from downwind (the three adjacent hexes of the fire's "forward arc"); note that wind direction must be determined to use this rule; see *Wind*, p. 57). The spreading of smoke occurs after drift and dissipation, as well as after players check for the spreading of fire. A fire does not create smoke in its own hex (though another fire may do so).

Use the Fire and Smoke Resolution Table to easily determine the order in which to resolve each fire and smoke action during the End Phase of each turn.

**Prohibited Conditions:** Cannot be used with Vacuum Atmospheric Pressure.

### FIRE AND SMOKE RESOLUTION SEQUENCE

Follow these steps, in order, during every End Phase:

1. Drift existing smoke clouds
2. Check for dissipation of existing smoke clouds
3. Check for spread of existing fires
4. Place new smoke clouds from existing fires (including any new fires started)
5. Check for weather conditions extinguishing existing fires (including any new fires started)

*In the Fire Diagram, during Turn 1 the 'Mech in Hex A on the City (Skyscraper) map fires a PPC and an LRM-20 at the Medium standard building in Hex B in an attempt to set it on fire. The Heavy Snowfall weather condition is in use and the players determined the wind direction before play began. Both attacks hit. Direct-fire energy weapons normally start fires on a die roll result of 7 or higher, but the player must modify this target number by +1 because the target is a Medium building, as well as +3 for the heavy snowfall, for a final modified Target Number of 11. Meanwhile, a missile weapon normally starts a fire on a die roll result of 9 or higher. Applying all the same modifiers, the controlling player determines that the final modified Target Number for the missiles is 13, so that weapon cannot start a fire in the target hex. The player rolls once for the direct-fire energy weapon with a result of 11! He's got his fire.*

*During the End Phase of Turn 1, the players automatically place a light smoke token in Hex F. As the building in hexes D and E is not apart of the building in Hex B, the light smoke for those two hexes is placed on the roof of those buildings, rising to Level 8 as the smoke is two levels tall; the players verify that the height of the burning material in Hex B (which is Level 4, the height of the building), is within 4 hexes of the height of hexes D and E, so the smoke tokens stay put in those hexes.*

*Also during the End Phase of Turn 1, since heavy snowfall is in effect, the players must determine if the fire is immediately put out. The players roll 2D6 for a result of 7. The +3 modifier for heavy snowfall brings the result to 10, 1 less than the number needed, so the fire is not extinguished.*

*During the End Phase of Turn 2, the players must drift smoke and check for dissipation. The players note that a light gale is in effect and so the smoke will only drift 1 hex. The "cloud" of smoke that occupies hexes D, E and F will move in the direction of the wind to occupy hexes H, I and J.*

*Next, the players must determine if that cloud of smoke dissipates. The players roll 2D6 for a result of 9, 2 less than the number needed, so the smoke cloud does not dissipate.*

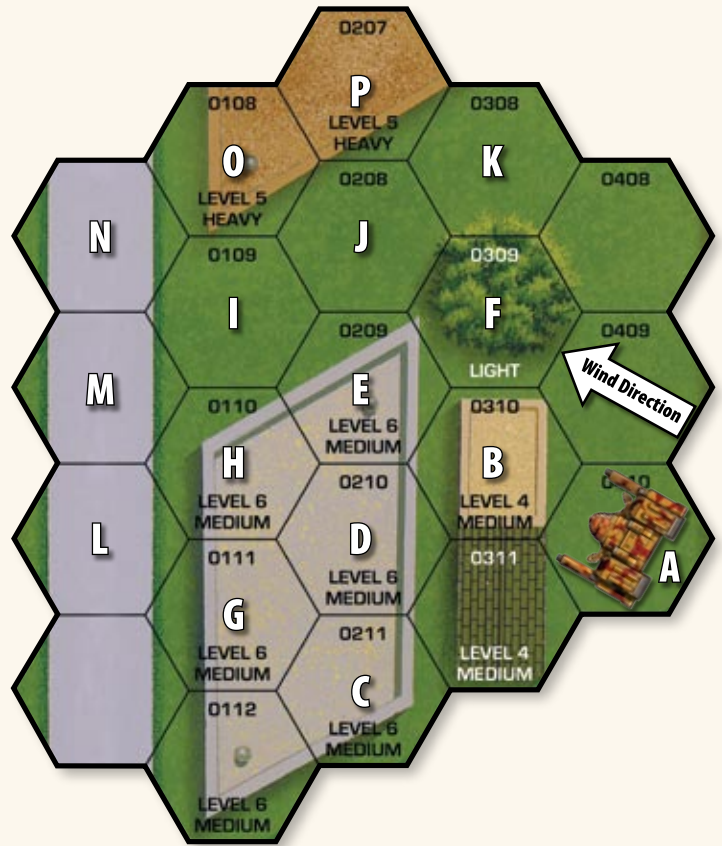

• FIRE DIAGRAM •

*Now the players place a new smoke cloud in hexes D, E and F as a result of the fire in Hex B.*

*Time now to see if the fire spreads. A light gale is in effect and so instead of the standard 9 and 11 target numbers, the players will be rolling against target numbers 7 and 10. For Hex E (directly downwind of Hex B), the 2D6 roll result of 6 does not equal or exceed the 7, so no fire is started. Another 2D6 roll is made each for hexes D and F at Target Number 10 each; roll results of 10 and 11 mean that both hexes are on fire! Now, under normal conditions, Hex I could potentially catch fire. However, it has two strikes against it. First, the building in Hex E is higher than the burning material in Hex B and the terrain in Hex I. Second, Hex I is clear...so no fire for that hex.*

*Next, the players check for dissipation against Target Number 11. A result of 7 means the smoke cloud did not dissipate.*

*Because two more hexes are on fire, the players place smoke counters. For the fire in Hex D, smoke is placed in hexes G, H and E (which they designate as Cloud 2 for ease of tracking); those building hexes are part of the same multi-hex building as Hex D, and so the smoke is on all levels inside the building, not on the roof. For the fire in Hex F, smoke will be placed in hexes E, J and K (designated as Cloud 3); the players verify that the height of the burning material (the woods) in Hex F is within 4 levels of the height of the building in Hex E and so the smoke is on the roof (even though 4 levels separate the smoke in Hex D from the other two hexes, they are still considered a "cloud" and will move together).*



Finally, for the heavy snowfall, the players must again determine if the fires go out. The players roll for each hex on fire and get results of 3, 5 and 6; with the +3 modifier added to each die roll result, no fires go out.

During the End Phase of Turn 3, the players must again drift smoke and check for dissipation. Cloud 1, which occupies hexes H, I and J, would normally drift into hexes M, N and O. While the smoke enters hexes M and N just fine, the Level 5 building in Hex O is more than 4 levels taller than the underlying terrain of Hex J, and so the smoke will not enter that hex. Instead, the smoke from Hex J will enter Hex N, shrinking Cloud 1 from three hexes to two and turning the light smoke in Hex N to heavy smoke.

Because Cloud 2 is in a building hex out of the wind, the players randomly roll a direction for the smoke to drift. A 1D6 roll result of 3 means Cloud 2 would normally enter hexes C, D and B. However, since Hex B is not part of the multi-hex building that Cloud 2 occupies and this movement places it directly opposite the direction of the wind, Cloud 2 will not enter that hex and so now occupies hexes C, D and E at all levels inside the building.

Cloud 3 would normally move from hexes E, J and K to I, O and P. As before, however, O and P contain Level 5 buildings, which are more than 4 levels higher than the underlying terrain in hexes J and I. Once again, the smoke cloud will change from three hexes to two, occupying hexes I and J, with the smoke in Hex I becoming heavy smoke.

Next, the players must determine dissipation, with the following results: 12, 8 and 3. Cloud 1 has dissipated.

Now the players place new smoke clouds. As previously, the fire in Hex B will place Cloud 4 in hexes D, E and F; Hex D will place Cloud 4 in hexes G, H and E (again, inside the building); the fire in Hex F will place Cloud 5 in hexes E, J and K.

Now it's time to check for the spread of the fires. Again, with the light gale in effect, the target numbers are 7 and 10. The players have three fires to look at and so randomly determine to start with Hex B. As hexes D and F are already on fire (and Hex I cannot be set on fire), the players only need to determine if Hex E catches fire. They get a 2D6 result of 7 and Hex E catches fire.

Next, the players roll for the fire in Hex D. For Hex H (directly downwind), the 2D6 roll result of 9 causes that hex to catch fire as well, while a die roll result of 9 for Hex G means that hex is not on fire. Hex E is already on fire, and so the players do not roll for that hex.

For the last fire in Hex F, Hex E is already on fire, while hexes J and K cannot catch fire. The final hex that can catch fire from Hex F is Hex O. The Target Number for being directly downwind is 7, but a +3 modifier is applied for the intervening non-burning hex, bringing the TN to 10. The 2D6 result of 9 means no fire starts in that hex.

The players remember to place smoke hexes for the fires that just started: the fire in Hex E will place smoke (Cloud 5) in hexes H, I and J (the smoke in Hex J is inside the building at all levels), while the fire in Hex H will place smoke (Cloud 6) into hexes L, M and I.

Finally, the players roll to determine if any of the hexes on fire are extinguished. 2D6 results of 7, 5, 3 and 9, after applying the +3 modifier, means that Hex H is extinguished even though the fire there just started.

## WIND STRENGTH TABLE

1D6 Roll	Wind Strength*
1–2	No Wind
3	Light Gale**
4	Moderate Gale**
5	Strong Gale**
6	Storm**

\*Tornado F1–F3 and Tornado F4+ Weather Conditions are not on this table, as smoke does not exist under such conditions.

\*\*See *Weather Conditions* (p. 57) for additional game effects from such wind conditions.

### Smoke

As with fire, smoke is not exactly a terrain modification in the same vein as the other rules that appear in this section. However, as it too can affect a unit's to-hit modifiers and is applied and tracked on a hex-by-hex basis (albeit usually across the duration of a game), the rules are most appropriately covered here.

**Light and Heavy Smoke:** Smoke is divided into two categories: light and heavy. Regardless of the type of smoke involved, it always rises 2 levels above the underlying ground terrain (if there are woods or jungle in a hex, the smoke does not rise 2 levels above the trees, but above the ground beneath them).

- **Light Smoke:** Light smoke is generated by most fires, as well as certain types of smoke-delivering weapons. In cases where the type of smoke is not specifically stated, assume it is light smoke. Light smoke acts as light woods for purposes of line of sight and attack modifiers.
- **Heavy Smoke:** Heavy smoke is usually created by smoke-delivering weapons, but it is also generated by burning Heavy or Hardened buildings, as well as fires set by inferno rounds or erupting lava. Heavy smoke acts as heavy woods for purposes of line of sight and attack modifiers.

**Smoke Drift/Dissipation:** Wind strength and direction will determine how smoke drifts and dissipates; players only start to determine drift and dissipation for smoke during the End Phase following the turn in which the smoke was initially placed. Use the standard rule for determining wind direction (see p. 57). To determine the strength of the wind—provided no wind conditions are already determined—roll 1D6 and consult the Wind Strength Table, above. If no specific wind strength is selected or generated, assume that Light Gale conditions prevail.

If players are using the Shifting Winds rules (see p. 57), those rules should be resolved first during the End Phase, before smoke drift and dissipation is resolved.

- **Drift:** In Light Gale and Moderate Gale winds, all smoke on the map drifts 1 hex per turn. In Strong Gale winds, smoke drifts 2 hexes per turn. Finally, in Storm winds, smoke drifts 3 hexes per turn. Smoke drifts during the End Phase of a turn in the direction of the prevailing wind. Any smoke that drifts off the edge of the playing area is removed from play. Smoke does not drift in Calm conditions. If two light smoke clouds drift into the same

INTRODUCTION

ADVANCED  
GROUND MOVEMENT

ADVANCED  
COMBAT

ADVANCED  
BUILDINGS

ADVANCED  
SUPPORT  
VEHICLES

GENERAL  
RULES

ADVANCED  
SUPPORT VEHICLE  
CONSTRUCTION

ADVANCED  
WEAPONS  
AND EQUIPMENT

INDEX

RECORD SHEETS



hex, they are considered heavy smoke for as long as the two occupy the same hex. Inside a building, smoke drifts 1 hex per turn in a random direction (see *Buildings*, below); if this would result in smoke exiting the building in a direction opposite the direction of the wind (if any), the smoke will stay in its hex. After resolving all smoke drift, determine smoke dissipation.

- **Level Changes:** As smoke enters a new hex, it will only change 4 levels up or down (taking into consideration the height of the burning material, whether a building, woods and so on); if the level change is 1 to 4 levels, the smoke will automatically adjust its 2 levels of height to the level of the underlying terrain in the new hex. If smoke enters a hex whose level is more than 4 levels below the hex it is exiting, the smoke automatically dissipates (see below). If smoke enters a hex whose level is higher than 4 levels above the hex it is exiting, it will not enter that hex. Instead, randomly determine the hex to the right or left; the smoke enters that hex instead. This may shrink the smoke hex or make it dive, depending upon the terrain. If the smoke cannot enter either of those adjacent hexes, it will stay in its current hex.
- **Buildings:** If smoke enters a building hex from another hex that is not part of the same building, the smoke does not affect the interior of the building; it will either be on top of the building, or depending on the level changes involved, may not enter the hex (see above). If smoke enters a building hex from a fire in the same multi-hex building, then the smoke affects all levels within that building hex (the smoke will not be on top of the building hex). If smoke exits from the interior of a building hex (as opposed to the roof), regardless of the height of the building, it will automatically be at the level of the underlying terrain in that new hex. If players are using the expanded Construction Factor rules (see p. 121), smoke drift should be determined by level (meaning it is only 1 level tall); in this case, smoke exiting a building does so at the level at which it is being tracked, which means the changes in levels to the new hex must be taken into consideration (see *Level Changes*, above). After that, if it still exists, it will rise the standard 2 levels tall.
- **Dissipation:** To determine dissipation, roll 2D6 for each cloud of smoke on the board during the End Phase of each turn (this is done after smoke drift, but before fire spreading is determined). A cloud is any amount of smoke that has been generated in a single turn and covers a single hex or a group of contiguous hexes. For example, a group of seven smoke hexes created by smoke LRMs is covered by a single cloud. (Use smoke markers of various shapes and sizes to keep track of clouds.) For Moderate Gale winds, add 1 to the roll result; in Strong Gale winds, add 3; in Storm Gale winds, add 5. If the final modified result is 11 or greater, the smoke cloud dissipates. A Light Smoke cloud that dissipates is removed from the map. A Heavy Smoke cloud that dissipates becomes Light Smoke. Do not add any modifiers to a roll made for a smoke cloud inside a building.

After resolving smoke drift and dissipation, determine if any continuing fire on the playing area generates more smoke or spreads.

**Prohibited Conditions:** Cannot be used with Vacuum Atmospheric Pressure.

## Geyser

On some planets, geologic activity creates geysers and mud spouts that can erupt without warning. Often, the only clues to a geyser's presence are small holes or cracks in the ground—clues that are easily overlooked by troops in combat. When a geyser erupts, it spews steam and water into the air, obscuring line of sight and making movement through the terrain more difficult.

Before beginning the game, geysers can be placed on the map in set locations; if a gamemaster is overseeing play, he can secretly select the geyser sites and conceal their locations from the players. In any case, a geyser has no effect on the underlying terrain until it erupts.

To reflect the unpredictable nature of geysers, the gamemaster or players determine geyser activity by rolling 1D6 for each geyser on the map during the End Phase of each turn.

On a result of 1, the geyser erupts, creating the effect listed on the Expanded Movement Cost and Terrain Table. Treat the erupting geyser as ultra-heavy woods for the purpose of determining line of sight into or through the hex.

To determine how many turns a geyser eruption lasts, roll 1D6. By keeping the duration secret from the players, a gamemaster can prevent the players from predicting when the effects will end.

Geyser rules can also be used to simulate the effects of small magma eruptions on volcanic planets. In such cases, any unit that enters or stands in a hex where a magma eruption occurs suffers the same effects as if it had fallen into liquid magma (see *Magma*, p. 36). After the eruption, treat the hex as a liquid magma hex for the remainder of the game.

**Terrain:** If a geyser is placed in any hex that contains any other type of terrain with a Terrain Factor/Construction Factor (buildings, woods, terrain modifications and so on), the geyser's eruption automatically reduces the Terrain Factor to 0 (see *Terrain Factor Rules*, p. 64). If this causes the terrain to collapse (such as a building), players resolved that event at the end of the phase in which the geyser erupted.

**Prohibited Conditions:** Cannot be used with Vacuum Atmospheric Pressures, or with Extreme Temperatures of -30 degrees Celsius and below.



On the battlefield, smoke can be an aid or hindrance.



### Hazardous Liquid Pools

Hazardous or caustic liquid represents manmade hazardous material (nuclear waste, chemical waste and so on) as well as naturally occurring alien substances, all of which can quickly damage manmade materials such as armor (much less what they can do to human skin).

While “dry” hazardous material can be just as dangerous, these game rules assume that it is more difficult to take damage from such contact. By comparison, hazardous liquid “pools” into a central, concentrated area, allowing for an immersion that can touch every surface of a unit for maximum damage.

Before beginning the game, pools of hazardous liquid can be placed on the playing area in set locations. Unlike geysers (see p. 48), these are not secretly placed—once a unit nears such a terrain modification, the pilot or driver can easily tell where it is located—or hidden, such as in the basement of a building, inside a tank and so on. These pools can be single- or multi-hex sized, as well as different depths. The ultimate hex size and depth of each pool—as well as how many pools—is left up to the players’ discretion. However, when placing each hazardous liquid pool, players should observe the following thumbnail rule: placing such pools in woods, jungle or residential building hexes, doesn’t really pass the “realistic” litmus test. In the end, though, provided all players agree, such pools can be placed anywhere.

For purposes of movement, Piloting/Driving Skill Rolls and unit prohibition, a hazardous liquid pool is considered a water hex.

Unlike many other types of terrain, which have a set effect, the nature of a pool of hazardous/caustic liquid—composed of myriad different chemicals constantly mixing—means that from one moment to the next its effect can change. Whenever a unit enters a hex containing a hazardous liquid pool (or begins the Ground Movement Phase in such a hex), the controlling player immediately rolls 1D6 and consults the Hazardous Liquid Pool Table to determine the damage to be applied to the unit. (When starting the Ground Movement Phase in such a hex, the controlling player makes the roll and assigns the damage before beginning movement.)

Once the total Damage Value of the attack has been determined through a dice roll, divide the damage into 5-point Damage Value groupings and assign each grouping to a random location (provided the unit has locations); if a ‘Mech is standing in a Level 1 hazardous liquid pool, the damage can only be applied to the legs.

**Support Vehicles:** Double the damage against Support Vehicles unless the vehicle is equipped with the Environmental Sealing Chassis and Controls modification.

**Infantry:** In the case of battle armor, each trooper takes the assigned damage. For conventional infantry, double the damage; it is assigned as though the attack came from another infantry unit (unless the infantry are XCT troops (see p. 351), in which case divide the damage by 3 [once any dividing of the dice roll result is done as noted on the table], rounding down to a minimum of 1.

**Water Hexes:** Players can decide to assign a Hazardous Liquid Pool terrain modification to a water hex. In such a case, the entire hex, no matter its depth, is considered this terrain modification.

Furthermore, as most such hazardous/caustic liquids are more viscous than water, they will adhere together, even if traveling through water, allowing players to move such terrain

## HAZARDOUS LIQUID POOLS TABLE

1D6 Roll	Classification	Damage*
1-2	Class 0: Normal	No Damage
3	Class 1: Slightly Hazardous	1D6/2 Damage
4	Class 2: Hazardous	1D6 Damage
5	Class 3: Extreme Danger	2D6/2 Damage
6	Deadly	2D6 Damage

\*Round all damage down.

modifications around the board (provided there are appropriate water hexes to enter). The Water Flow rules must be in use to move hazardous liquid pools around the board (see p. 52).

Adding this element to the game will require some adjudication. First, if there are very few water hexes on the playing area, the added complexity of these rules probably does not outweigh the added fun of such a feature. Second, multi-hex hazardous liquid pools can be very hard to adjudicate in terms of how they react with water as they flow into smaller or larger areas, and so only single-hex hazardous liquid pools can be assigned to water hexes.

The following rules build on the Water Flow rules (see p. 52).

- **River:** During the End Phase of every turn, a hazardous liquid pool will travel 1 hex in the direction of the flow of water, into the most appropriate hex; if multiple hexes are equally appropriate, determine randomly which hex the pool enters. While it can enter a Depth 0 water hex, it cannot enter a non-water hex; if it would logically enter a non-water hex, either choose another appropriate hex or, depending on the flow of the water, the hazardous liquid pool may stay in the water hex adjacent to the non-water hex. If the hazardous liquid pool starts the turn in a hex that also contains the Rapids terrain modification (see p. 50), it will move 2 hexes; if the hex contains the Torrent terrain modification (see p. 52), it will move 3 hexes.
- **Lake:** The hazardous liquid pool will travel 1 hex in the direction of the flow of water; if the pool starts the turn in a hex that also contains the Rapids terrain modification (see p. 50), it will move 2 hexes; if the hex contains the Torrent terrain modification (see p. 52), it will move 3 hexes. While it can enter a Depth 0 water hex, it cannot enter a non-water hex; if it would logically enter a non-water hex, either choose another appropriate hex or, depending on the flow of the water, the hazardous liquid pool may stay in the water hex adjacent to the non-water hex.

**Eruptions:** The erupting magma rules (see p. 37) can be adapted for alien environments, where caustic and strange liquids are not simply found in stagnant pools, but can suddenly erupt into the air, spewing their toxic mix. Use the mechanics for determining when an eruption will occur; once it does, use the radius of effect in the erupting magma rules, but instead of applying damage for magma, roll to determine what type of liquid has erupted and apply that damage, as appropriate; the erupting target hex is now a Depth 1 hazardous liquid pool (1 depth below the previous level of the underlying terrain; ignore all previous terrain).

INTRODUCTION

ADVANCED  
GROUND MOVEMENT

ADVANCED  
COMBAT

ADVANCED  
BUILDINGS

ADVANCED  
SUPPORT  
VEHICLES

GENERAL  
RULES

ADVANCED  
SUPPORT VEHICLE  
CONSTRUCTION

ADVANCED  
WEAPONS  
AND EQUIPMENT

INDEX

RECORD SHEETS



**Prohibited Conditions:** Cannot be used with Vacuum Atmospheric Pressure, or with Extreme Temperatures of  $-30$  degrees Celsius and below.

## Ice

Prior to the start of a game, players should indicate which hexes are ice-coated. Water hexes must be designated as either ice-covered or frozen solid.

**'Mechs and Non-Hover Ground Vehicles:** Apply a +4 modifier to any Piloting/Driving Skill Rolls made in an ice hex, and units must spend extra MP when moving across Ice hexes or risk falling (see *Careful Movement*, p. 63). In addition, 'Mechs and ground vehicles that make a facing change and then move on an ice-coated hex must check to see if they skid (see *Skidding*, p. 62, *TW*), even if they are moving at Walking or Cruising speed. If using Hurried Movement (see p. 20) in a hex with ice, apply another +3 modifier (this is in addition to all the the modifiers noted above).

**Breaking Through Ice:** Any 'Mech or ground vehicle that enters an ice-covered water hex may break through the ice and fall into the water below unless the hex is frozen solid. VTOLs and WiGE vehicles can only break through the ice if they are landing on it. Roll 1D6. On a result of 6, the ice breaks and the unit falls into the water. 'Mechs take one-half normal falling damage (for falling in water). If an IndustrialMech mounts a fuel cell, fission or fusion power plant and the Environmental Sealing Chassis and Controls modification, use the standard rules as noted in this section; otherwise, it is destroyed. Vehicles are destroyed (but hovercraft are unaffected unless the unit is immobilized, in which case it is destroyed). The water hex remains unfrozen for the remainder of the game.

Note that the tonnage of the unit is not a factor in breaking through the ice—breaking through depends on ground pressure, not overall weight. Larger BattleMechs and vehicles have larger “footprints,” so the weight of their presence on the ice exerts pressure per square meter as low as that of lighter units with smaller footprints.

After falling through the ice, a 'Mech can climb out of a Depth 1 or Depth 2 water hex and move back onto the ice. A 'Mech in Depth 3+ water must travel under the ice, following the underlying terrain, until it reaches a Depth 2 hex, at which point it can break through the ice (see *Underwater Movement*, p. 56, *TW*), or until it reaches a Depth 1 hex, at which time it automatically breaks through the ice, converting the hex to open water.

A ProtoMech can only climb out of a Depth 1 hex.

**Jumping:** For jumping 'Mechs that land on an ice-covered water hex, roll 1D6. On a result of 4+, they break the ice and fall through. If the ice does not break, the 'Mech must make an immediate standard Piloting Skill Roll with an additional +4 modifier to remain standing; if it fails, it takes normal falling damage, and another roll must be made immediately to see if the ice breaks (this time only on a 6 or greater).

**Crashing:** VTOL and WiGE vehicles crashing into a hex roll 1D6. On a result of 4+, they break through the ice and are automatically destroyed.

**Mobile Structure:** A Mobile Structure automatically breaks through ice if it enters an ice hex.

**Non-Spheroid Aerospace Unit:** Apply a +2 modifier to the landing/lift-off roll for every hex of ice entered by a landing or lifting-off non-Spheroid aerospace unit.

**Spheroid Units:** A landing Spheroid unit automatically converts any ice hexes it lands in into the hex's underlying terrain: clear, rough and so on.

**Infantry:** Unless a battle armor unit has UMU MP, or a conventional infantry unit has the SCUBA specialization (see p. 341), if an infantry unit is in an ice hex that breaks and it falls into water, the unit is destroyed.

**Terrain Factor:** An ice-covered water hex can be converted into a normal water hex by melting the ice with weapons fire (see *Terrain Factor Rules*, p. 64); see *Weapons Fire*, below, for additional ways that weapons fire can eliminate ice. Units (except Hover and airborne VTOL and WiGE Vehicles) occupying a hex converted in this way fall into the water.

**Fire:** If a fire is started in a hex that includes ice, after two turns during the End Phase the ice is reduced to mud.

**Weapons Fire:** If a flamer, incendiary LRMs or plasma weapon is used on an ice hex to try to start a fire (see p. 43), roll 2D6. On a result of 10, the Ice terrain modification is converted to mud or water, as appropriate for the underlying terrain; no fire is started. Weapons fire that strikes the hex from a missed shot (see p. 81) is ignored. However, if missile infernos, inferno fuel ammo, inferno-IV artillery or inferno bombs hit a target hex (whether intentionally or not), the Ice terrain modification is automatically reduced to mud; as above, no fire is started.

**Prohibited Conditions:** Cannot be used with Extreme Temperatures of 30 degrees Celsius and above.

## Mud

A quick and easy way to apply mud to a playing area is to make any Depth 0 water hex mud. As always, though, players can choose to add mud however they wish.

Apply a +1 MP cost to enter a mud hex, as well as a +1 modifier to all Driving Skill Rolls made while in that hex.

Units entering a hex containing the Mud terrain modification may also get stuck (see *Bog Down Rules*, p. 62)

**'Mechs, Hover Vehicles and Mobile Structures:** 'Mechs, Hover Vehicles and Mobile Structures ignore mud.

**Non-DropShip Aerospace Units/VTOLs/WiGEs:** These units only make a Bog Down Roll if they end their movement on the ground in such a hex; DropShips never get stuck in mud.

**Spheroid Units:** A landing Spheroid unit automatically converts any mud hexes it lands in into the hex's underlying terrain: clear, rough and so on.

**Prohibited Conditions:** Cannot be used with Vacuum Atmospheric Pressures, or with Extreme Temperatures of  $-30$  degrees Celsius and below.

## Rapids

For any water of Depth 1 or greater that contains rapids, apply a +1 MP cost to enter that hex, as well as a +2 modifier to all Piloting Skill Rolls made while in that hex.

**Water Flow:** All the rules for water flow (see p. 52) also apply to rapids, with the following additions.

A unit that fails a Piloting Skill Roll, in addition to falling, will be displaced 2 hexes in the direction of the flow of water. Additionally, all Naval Vehicles on the surface of the water, in order not to be moved by water flow, must spend 1 MP at the end of their movement in order to “hold position” in the hex where they ended their movement. If the MP are not spent, the Naval Vehicle is displaced 2 hexes in the direction of the flow of water; if only 1 MP is spent at the end of movement, the Naval Vehicle is only displaced 1 hex. As with failing a Piloting Skill Roll, a unit cannot be displaced into a Depth 0 water hex.



**Prohibited Conditions:** Cannot be used with Trace or Vacuum Atmospheric Pressures, or with Extreme Temperatures of -30 degrees Celsius and below.

### Rails

Rails represent a variety of tracks, from traditional steel rails on wooden ties to advanced extruded ferrocrete troughs for maglevs and more. However, all of them act as a road, in that a rail passes through terrain of some other type in a hex.

A rail hex is treated as rough terrain by all ground vehicles and 'Mechs, but has no effect on any other unit's movement and does not affect line of sight. As with a road (see p. 61, *TW*), if such units are traveling along the rail, they only need to pay the cost for moving in a rough hex, not the additional cost of whatever may be the underlying terrain.

Railroads have a CF of 20 and may be attacked per standard rules for attacking buildings. Once destroyed, a rail hex is treated as a clear hex for movement and line of sight.

**Rail Support Vehicles:** For Rail Support Vehicles to move on a mapsheet, they must move through a continuous, unbroken line of rail hexes (see *Rail*, p. 149).

### Roads

As noted on p. 61 of *Total Warfare*, a road is simply a narrow strip of cleared terrain that passes through terrain of some other type. The rules in *TW* represent a paved road. However, there are other types of road that provide varying effects for different unit types.

All the standard rules for road movement as noted on p. 61, *TW*, still apply.

**Dirt Road:** Tracked and Hover vehicles (except Large Vehicles) and infantry traveling on a dirt road pay only 1 MP per hex, regardless of the hex's underlying terrain. Infantry (except mechanized) using Ground Movement on a dirt road may receive a movement bonus of 1 MP. To gain the extra MP, the unit must begin its turn on a dirt road and continue to travel on the dirt road for the entire Movement Phase.

**Gravel Road:** Vehicles (except Large Vehicles) and infantry traveling on a gravel road pay only 1 MP per hex, regardless of the hex's underlying terrain. Infantry, Hover and Tracked ve-

hicles using Ground Movement on a gravel road may receive a movement bonus of 1 MP. To gain the extra MP, the unit must begin its turn on a gravel road and continue to travel on the dirt road for the entire Movement Phase.

### Swamp

Apply a +2 MP cost to enter a hex with the Swamp terrain modification, as well as a +2 modifier to all Driving Skill Rolls made while in that hex. Units may also get stuck (see *Bog Down Rules*, p. 62).

**'Mechs:** 'Mechs only apply a +1 MP cost to enter a swamp hex, as well as a +1 modifier to all Piloting Skill Rolls made while in that hex. 'Mechs or vehicles that jump into a swamp hex are automatically stuck (see *Bog Down Rules*, p. 62).

**Hover Vehicles and Mobile Structures:** Hover Vehicles and Mobile Structures ignore swamps.

**Non-DropShip Aerospace Units/VTOLs/WIGEs:** Any of these units that end their movement on the ground in a swamp hex are automatically stuck (see *Bog Down Rules*, p. 62).

**Small Craft and DropShips:** If a Small Craft or DropShip ends its movement on the ground, and all hexes it touches on the ground are swamp hexes, then it might get stuck (see *Bog Down Rules*, p. 62).

**Quicksand:** A swamp hex can also unexpectedly turn into quicksand; it remains quicksand for the rest of the scenario. Anytime a unit (not including DropShips) enters a swamp hex and becomes stuck, roll 2D6. On a result of 12, the swamp hex has become a quicksand hex. If a unit is in a hex that turns to quicksand, or enters a quicksand hex, it automatically gets stuck.

During every End Phase after the turn in which the swamp hex becomes a quicksand hex, the unit will sink 1 level; apply a +3 modifier to the Piloting Skill Roll to get unstuck from a quicksand hex, as well as a cumulative +3 modifier for each level under the surface. As soon as the surface of the quicksand hex is higher than the unit in question, the unit is destroyed.

**Prohibited Conditions:** Cannot be used with Vacuum Atmospheric Pressure, or with Extreme Temperatures of -30 degrees Celsius and below.

*During the Movement Phase of Turn 1, an infantry unit entered a swamp hex and did not get stuck. However, it did not have enough MP to exit the hex, and when a 'Mech entered the same hex and got stuck, the controlling player rolled 2D6 with a result of 12! The hex became a quicksand hex, and so the infantry unit is automatically stuck along with the 'Mech. During the Movement Phase of Turn 2, both units must make Piloting Skill Rolls to try to get unstuck, both applying a +3 modifier. Neither roll is successful, and during the End Phase of Turn 2, both units sink 1 level. During the Movement Phase of Turn 3, both players must make a successful Piloting Skill Roll with a +5 modifier. Again, neither is successful, and during the End Phase of Turn 3 both units sink another level. The surface of the quicksand hex is now higher than the infantry and so the infantry unit is destroyed. During the Movement Phase of Turn 4, the 'Mech has one final chance at getting unstuck by making a successful Piloting Skill Roll with a +7 modifier. If this roll fails, during the End Phase of Turn 4 the 'Mech will sink 1 more level. That will put the surface of the quicksand higher than the 'Mech, destroying the unit.*



Free Rasalhague Republic troops guard an important crossroads.

INTRODUCTION

ADVANCED  
GROUND MOVEMENT

ADVANCED  
COMBAT

ADVANCED  
BUILDINGS

ADVANCED  
SUPPORT  
VEHICLES

GENERAL  
RULES

ADVANCED  
SUPPORT VEHICLE  
CONSTRUCTION

ADVANCED  
WEAPONS  
AND EQUIPMENT

INDEX

RECORD SHEETS



### Thin Snow

If a scenario uses thin snow, apply the following rules.

**Wheeled Vehicles and Conventional Infantry:** Apply a +1 MP cost per hex (unless the vehicle mounts the Snowmobile Chassis and Controls modification) and a +1 modifier to all Driving Skill Rolls.

**Fire:** If a fire is started in a hex that includes thin snow, during the End Phase of the following turn, the snow is reduced to mud.

**Weapons Fire:** If a flamer, incendiary LRMs or plasma weapon is used on a thin snow hex to try to start a fire (see p. 43), roll 2D6. On a result of 8, the Thin Snow terrain modification is reduced to mud; no fire is started. Weapons fire that strikes the hex from a missed shot (see p. 81) is ignored. However, if missile infernos, inferno fuel ammo, inferno-IV artillery or inferno bombs hit a target hex (whether intentionally or not), the thin snow is automatically reduced to mud; as above, no fire is started.

**Spheroid Units:** A landing Spheroid unit automatically converts any thin snow hexes it lands in into the hex's underlying terrain: clear, rough and so on.

**Note:** Unless the underlying terrain is specified in the scenario rules, the players may agree to treat the underlying terrain of thin snow as ice (see p. 50) or Clear terrain.

**Prohibited Conditions:** Cannot be used with Vacuum Atmospheric Pressure, or with Extreme Temperatures of 30 degrees Celsius and above.

### Torrent

For any water hex of Depth 1 or deeper that contains torrents, apply a +2 MP cost to enter that hex, as well as a +3 modifier to all Piloting Skill Rolls made while in that hex.

**Water Flow:** All the rules for water flow (below) also apply to water flow for torrents, with the following additions.

A unit that fails a Piloting Skill Roll, in addition to falling, is displaced 3 hexes in the direction of the flow of water. Additionally, all Naval Vehicles on the surface of the water, in order not to be moved by water flow, must spend 3 MP at the end of their movement in order to "hold position" in the hex where they ended their movement. If the MP are not spent, the Naval Vehicle is displaced 3 hexes in the direction of the flow of water; if only 2 MP are spent at the end of the movement, then the Naval Vehicle is only displaced 1 hex; if only 1 MP is spent, then the Naval Vehicle is only displaced 2 hexes. As with failing a Piloting Skill Roll, a unit cannot be displaced into a Depth 0 water hex.

**Prohibited Conditions:** Cannot be used with Trace or Vacuum Atmospheric Pressures, or with Extreme Temperatures of -30 degrees Celsius and below.

### Water Flow

In standard *Classic BattleTech* rules, the flow of water in a water hex does not have any effect on a game. However, particularly when using some terrain modifications—such as rapids and torrents—the flow of water can add a fun, tactical element.

Before play begins, all water hexes on the playing area must be classified as a "river hex" or a "lake hex;" generally speaking, a river on a map is a thin number of continuous water hexes that actually crosses a portion of the map. For purposes of these rules, a river flows in one direction, while a lake can flow in multiple directions.

Once the players have agreed which water hexes on the playing area are river hexes and which are lake hexes, use the following rules.

- **River:** A river flows in one direction or the other; the players need to determine which two directions the river can possibly flow. Before beginning play, roll 1D6. On a result of 1–3, it flows in one direction, while on a result of 4–6, it flows in the opposite direction. This direction of flow continues for the duration of the scenario.
- **Lake:** Whenever necessary—when something is in the hex that may be moved by the flow of water—check to see the direction of a lake hex. Declare one side of the water hex to be Direction 1 (using the numbered hexside as Direction 1 is helpful), and then number the remaining hexsides as 2 through 6, moving clockwise. Now roll 1D6. The water is currently traveling in the direction that corresponds to the roll result. This check need only be made once per turn; regardless of when it is made in the turn, that direction of flow applies to all units, conditions and so on. On a subsequent turn, if necessary, a new check is made to determine the direction of water flow.

If a unit in a water hex fails a Piloting Skill Roll, in addition to falling, it is displaced 1 hex in the direction of the flow of water. However, a unit cannot be displaced into a Depth 0 water hex, or any non-water hex; if it would enter a Depth 0 water hex or a non-water hex, either choose another appropriate hex or, depending on the flow of the water, the unit may stay in the water hex adjacent to the hex it cannot enter.

Additionally, all Naval Vehicles on the surface of the water, in order not to be moved by water flow, must spend 1 MP at the end of their movement in order to "hold position" in the hex where they ended their movement. If the MP is not spent, the Naval Vessel is displaced 1 hex in the direction of the flow of water. As with failing a Piloting Skill Roll above, a unit cannot be displaced into a Depth 0 water hex.

A unit displaced by water flow automatically changes its facing to most appropriately match the direction of water flow. For a vehicle, this will be either the nose or rear; for a fallen 'Mech, this will be either head or feet.

If multiple units within a hex must be moved by water flow, randomly determine which units to move first, then completely resolve each unit's movement (and any fallout from such movement) before moving on to the next unit. For example, such movement may cause a displacement and/or domino effect (see p. 151, *TW*).

In all instances, movement due to water flow occurs at the end of the Movement Phase (Ground); all water movement is simultaneous and is resolved on the playing area after all other movement is resolved that occurs during the Movement Phase (Ground).

*In the Water Flow Diagram on p.53, a 'Mech and two identical Naval Vehicles are moving through water on the BattleForce map. Prior to the start of play, the players determined that hexes A and B (as well as the other hexes to the right and bottom of hexes A and B) are lake hexes, while hexes C, D, E and F are river hexes. Additionally, they determined the direction of the flow of water for the river hexes, which will remain constant for the entire scenario. Finally, a Torrent terrain modification is in effect for the river hexes.*

*During the Movement Phase of Turn 1, the 'Mech in Hex A entered the Depth 1 water in that hex and failed a Piloting Skill Roll, which means it falls; it doesn't have enough MP remaining to stand again. The controlling player rolls 1D6 to determine the direction of the fall and gets a result of 3: two*



hexsides right. Additionally, the controlling player forgot to keep 1 MP reserved for both his Naval Vehicles, so they are also at the mercy of the water.

Because lake hexes A and B are now occupied by units that can be affected by water flow, the direction of flow for each hex is determined; as it is a lake hex, they can both be moved in different directions. For Hex A and for Hex B, the 1D6 die roll result is 1. As a unit cannot be displaced into a non-water hex by water flow, the Naval Vehicle in Hex B will not enter Hex H and remains in its current hex (its facing does not change because it did not enter a new hex). However, both the Naval Vehicle and the 'Mech in Hex A are moved into Hex C. The Naval Vehicle's facing is changed so that its front is now facing Hexside 1, while the 'Mech's facing is changed so that its facing is now Hexside 4. Because all water flow is simultaneous, the movement of the river hexes does not apply to the units that were moved into Hex C by water flow.

During the Movement Phase of Turn 2, the player manages to stand the 'Mech back up, but cannot get it out of the water. Additionally, the player remembers to reserve 3 MP (as the units are now in a torrent hex) for the Naval Vehicle in Hex C to remain in place. Unfortunately, combat the previous turn made the Naval Vehicle in Hex B immobile, so it is unable to expend the 1 MP required to remain in place in a lake hex; it will drift with the water. The controlling player once again rolls to determine direction of the lake hex and gets a 6. Worse luck! As the Naval Vehicle in Hex B is displaced into Hex C (its facing changes so it is now facing Hexside 3), the stacking rules are violated, and so the player randomly determines which unit will be displaced. Another die roll result determines that the 'Mech is displaced. The 'Mech is then moved into Hex D. Because this displacement occurred due to stacking limit violation rather than water flow, the 'Mech's facing does not change; the water flow in Hex D does not affect the 'Mech, as water flow occurred before the unit's displacement.

If the 'Mech fell in Hex D during the Movement Phase of Turn 3 and was unable to stand up again, the torrent river flow would finally come into play, moving the 'Mech from Hex D, through hexes E and F, and finally into Hex G, changing its facing appropriately.

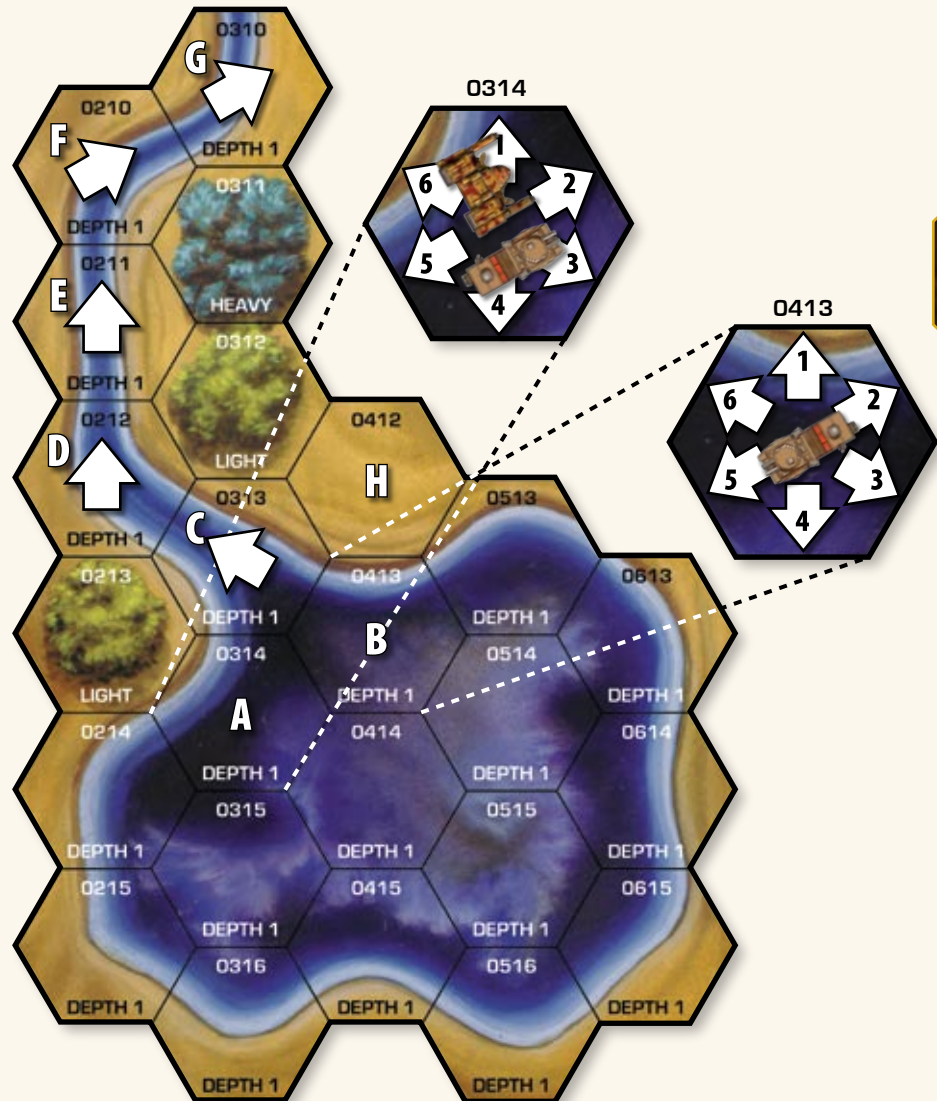

• WATER FLOW DIAGRAM •



Jeremiah Youngblood jumps his Phoenix Hawk into a turbulent lake.

INTRODUCTION

ADVANCED GROUND MOVEMENT

ADVANCED COMBAT

ADVANCED BUILDINGS

ADVANCED SUPPORT VEHICLES

GENERAL RULES

ADVANCED SUPPORT VEHICLE CONSTRUCTION

ADVANCED WEAPONS AND EQUIPMENT

INDEX

RECORD SHEETS



## TERRAIN CONDITIONS

Terrain conditions represent global terrain and/or environmental conditions, such as vacuum, high and low gravity, toxic atmosphere and so on.

As noted previously, modifiers and unit prohibitions imposed by terrain conditions are added to modifiers and unit prohibitions imposed by the underlying base terrain type and terrain modifications.

The following entries describe rules for terrain conditions.

### Atmospheric Pressure (Density)

A myriad of worlds and planetoids make up the Inner Sphere, many of them with atmospheric pressures stretching from vacuum (effectively no atmosphere at all), to very high (dense), or somewhere in between. The following rules simulate these various conditions.

**Vacuum:** If a scenario takes place under such conditions, modify movement and combat as follows.

- All BattleMechs and battle armor are capable of operating in a vacuum.
- **Prohibited Units:** Vehicles, conventional infantry and conventional fighters cannot operate in a vacuum. The only exceptions are the following: any non-infantry unit that mounts both a fusion engine (in the case of IndustrialMechs, this also includes fuel cells and fission power plants) and the Environmental Sealing Chassis and Controls modifications can operate in a vacuum; for conventional infantry, if the unit are XCT troops (see p. 351), it can also operate in a vacuum.
- **Non-Spheroid Aerospace Units:** Non-Spheroid aerospace units that fit the criteria for operating in a vacuum move on the board as though they were Spheroid units; conventional fighters and Fixed-Wing Support Vehicles must mount VSTOL equipment.
- **Hull Integrity:** Whenever a non-aerospace/non-infantry unit operating in a vacuum takes a hit that inflicts damage, the controlling player rolls 2D6.

On a result of 10 or greater, the unit's hull has been breached. The integrity of that location has been lost and all components in that location are exposed to vacuum. If all of a location's armor is destroyed, that location is automatically breached. Treat all of a 'Mech's components in a breached location as nonfunctional. None of that location's actuators, weapons or other equipment works; if the breached location contains engine slots, the engine now functions as if it took as many critical hits as there were engine critical slots in that location.

Note that these hits are not technically critical hits and, for example, will not cause ammunition to explode. Equipment and components in the breached location can still take critical hits per the standard rules, even though the component is temporarily nonfunctional.

Breached locations continue to take damage as usual. Do not transfer combat damage inflicted on a breached location until that location's internal structure is destroyed.

- **'Mechs:** If a 'Mech's head is breached, the pilot is automatically killed. Additionally, a life-support critical hit eliminates the 'Mech's internal air supply. During the End Phase of every turn that the 'Mech remains in vacuum, the pilot takes 1 point of damage. Each point of Life Support damage requires the pilot to make an immediate Consciousness Roll. A failure inflicts a point of damage on

the pilot. Until the unit is removed from the game (is destroyed, the pilot ejects and so on), a Consciousness Roll must be made at the end of every turn in which the pilot is active and the Life Support remains damaged. Every failure inflicts an additional point of damage on the pilot.

- **ProtoMechs:** If a ProtoMech's center torso is breached, the pilot is automatically killed.
- **Vehicles:** If any location on a vehicle is breached in a vacuum, the vehicle is destroyed.
- **Infantry:** As noted above, conventional infantry units that are XCT Troops (see p. 351) can function normally in a vacuum. However, double any damage taken by an infantry unit while operating in a vacuum to represent the loss of personnel due to suit breaches, damage that normally would not result in any casualties.

**Trace Atmosphere:** If a scenario takes place under such conditions, modify movement and combat as follows. Trace Atmosphere follows all the same rules for Vacuum Atmosphere noted above, except the following.

- **Non-Spheroid Aerospace Units:** Non-Spheroid aerospace units that fit the criteria for operating in a Trace Atmosphere move on the Low-Altitude Map as though they were moving in Atmospheric Row 4 on the High-Altitude Movement map (see p. 79, *TW*); all movement on the High-Altitude Map is considered to be at Atmospheric Row 4.
- **Hull Integrity:** Breaches only occur on a result of 12.
- **Wind Condition:** If wind conditions are used with Trace Atmosphere, the Trace Atmosphere reduces the wind speed by two categories, so that a Strong Gale would become a Light Gale and a Moderate Gale would mean no wind condition at all.

**Thin Atmosphere:** If a scenario takes place under such conditions, modify movement as follows.

- **WiGE, VTOL and Hovercraft:** Apply a -2 Cruising MP penalty (multiply the new Cruising MP by 1.5 and round down to determine the new Flanking speed); WiGE Vehicles must expend 7 MP to take off.
- **Non-Spheroid Aerospace Units (excluding Airships):** Increase the number of landing/liftoff hexes required by such units by 1.5 (round up).
- **Wind Condition:** If wind conditions are used with Thin Atmosphere, the Thin Atmosphere reduces the wind speed by one category, so that a Strong Gale would become a Moderate Gale.

**Standard Atmosphere:** This represents Terran standard and so no additional effects apply to movement and combat.

**High Atmosphere:** If a scenario takes place under such conditions, modify movement as follows.

- **WiGE, VTOL and Hovercraft:** Apply a +1 Cruising MP (multiply the new Cruising MP by 1.5, rounding down, to determine the new Flanking speed); WiGE Vehicles must expend only 4 MP to take off.
- **Airships:** Each .1-bar atmosphere above 1.2 increases an Airship's carrying capacity by 10 percent (round down).
- **Non-Spheroid Aerospace Units (excluding Airships):** Decrease the number of landing/liftoff hexes required by such units by .75 (round up).
- **Wind Condition:** If wind conditions are used with High Atmosphere, the High Atmosphere increases the wind speed by one category, so that a Strong Gale would become a Storm; this cannot increase the wind condition above a Tornado F4+.



INTRODUCTION

ADVANCED GROUND MOVEMENT

ADVANCED COMBAT

ADVANCED BUILDINGS

ADVANCED SUPPORT VEHICLES

GENERAL RULES

ADVANCED SUPPORT VEHICLE CONSTRUCTION

ADVANCED WEAPONS AND EQUIPMENT

INDEX

RECORD SHEETS



**Very High Atmosphere:** If a scenario takes place under such conditions, modify movement as follows.

- **Aerospace Units:** Instead of 4 rows on the High-Altitude Map between the Ground Hexes row and Space/Atmosphere Interface row (see p. 79, *TW*), there are 7 rows.
- **Wind Condition:** If wind conditions are used with Very High Atmosphere, the Very High Atmosphere increases the wind speed by two categories, so that a Strong Gale would become a Tornado F1-F3; this cannot increase the wind condition above a Tornado F4+.

### Earthquake

If a scenario takes place under such conditions, modify movement and combat as follows.

When using the earthquake rules, assign a strength value to the tremor, ranging from +1 (mild) to +5 (severe). Apply this value as a to-hit modifier to any weapon or physical attacks made during the same turn as the tremor. Additionally, players must make a Piloting Skill Roll for each standing 'Mech they control at the start of each Movement Phase during the tremor. Apply a Piloting Skill Roll modifier equal to the strength of the tremor. If the Piloting Skill Roll fails, the 'Mech falls and takes damage per standard rules. If the Piloting Skill Roll result equals 2, a fissure may open up beneath that 'Mech. Make a second roll and check the Basements Table (see p. 179, *TW*) to determine if a fissure opens and the sublevel of the fissure. The 'Mech will fall into the fissure the same way it would fall into a basement. Treat the fissure as a permanent map feature of Sub-level 1 or Sub-level 2 for the remainder of the scenario.

**Four-legged 'Mechs:** For four-legged 'Mechs, the Piloting Skill Roll modifier equals half the strength value of the tremor, rounding down (their extra legs provide improved stability). The standard -2 Piloting Skill Roll modifier for four-legged 'Mechs applies as well.

### Electromagnetic Interference (EMI)

Many worlds and settings in the *BattleTech* universe remain so rich in heavy metals or are inundated with such powerful background radiation (caused by everything from an irregular planetary magnetic field to local solar activity) that even the well-shielded sensors and communications gear used by BattleMechs, ground vehicles and battle armor are overwhelmed by the resulting interference.

If a scenario takes place under such conditions, modify combat as follows.

Apply a +2 to-hit modifier for all ranged weapon attacks and a -2 penalty to rolls on the Cluster Hits Table (regardless of the weapon system used) made by all units operating within an affected area. This area of effect may cover the entire playing area, or—if the players and/or gamemaster decide—be confined to select mapsheet-sized regions, to represent a more localized phenomenon.

Additionally, all active probes within an EMI-affected region are rendered useless, while ECM systems double their effective range.

### High/Low Gravity

Combat on worlds whose gravity is significantly greater or less than normal Earth gravity (1 G) affects a unit's movement.

**Determining Movement Effects:** As shown in the following rules, while low gravity generally allows units to move faster, it does not reduce their mass and momentum, and so offers a chance that the unit will suffer damage through normal movement. For example, a 'Mech traveling at 200 kph on a .5-G world is likely to snap off its legs. Gravity affects all units' movement in the same way. To determine a unit's movement rates as affected by gravity, divide its Walking (or Cruising) and Jumping MP by the G-rating of the world and round to the nearest whole number (round down at .5).

Calculate the new Running (or Flanking) MP based on the revised Walking (or Cruising) MP.

Thus, a unit with a normal Walking MP of 4 would have Walking MP of 5 on a .75-G world ( $4 \div .75 = 5.3$ , rounded to 5). On a 1.25-G world, that same unit would have a Walking MP of 3 ( $4 \div 1.25 = 3.2$ , rounded to 3). Units whose MP is reduced to 0 by the effects of gravity are incapable of moving.

**Potential Damage From Running/Flanking Movement:** 'Mech legs and vehicle suspensions are designed to operate at maximum efficiency on worlds with close to 1 G gravity. If the gravity of a world allows the unit to move faster than normal, the strain on the unit's systems may damage its internal structure. If a unit spends more MP than its normal Running (or Flanking) MP during a turn (as in the example above of the unit moving on a world with .75 G), the player must make a Piloting Skill Roll at the end of the phase in which the Running MP was exceeded, appropriately modified for relevant conditions, to determine if the unit takes any damage from moving at an unusual rate. If the Piloting Skill Roll fails, the unit takes the following damage: a 'Mech takes 1 point of internal structure damage to each of its legs for every point of movement by which the unit exceeded its normal Running MP (the 'Mech does not fall if this roll fails). Thus, a 'Mech with a normal Running MP of 8 that spends 10 MP running during a turn and then fails a Piloting Skill Roll would take 2 points of internal structure damage to each of its legs. A vehicle takes 1 point of damage to its Front side internal structure for each Movement Point spent that exceeds its normal Flanking Speed MP and must make a single roll on the Motive System Damage Table (regardless of how much damage is received, only a single roll is made). Roll on the Determining Critical Hits Table to resolve whether internal structure damage resulted in a critical hit. Apply critical hit results before the Weapon Attack Phase of the turn.

**Potential Damage From Jumping:** Make a Piloting Skill Roll, adding the appropriate modifiers for low gravity; a standard Piloting Skill Roll is made in high gravity, with no modifiers. If the roll fails for low gravity, the BattleMech takes 1 point of internal structure damage to each leg for each Movement Point spent jumping that exceeds its normal Jumping MP. If the roll fails for high gravity, the BattleMech takes 1 point of internal structure damage to each leg for every 1 Walking MP lost from its normal Walking MP.

**Falling:** Calculate damage from falls taken in unusual gravity normally, then multiply the result by the G-rating of the world and apply the total damage to the unit.

**ProtoMechs:** A ProtoMech's MP is not increased for low gravity, though it is reduced for high gravity. A ProtoMech does not need to make a roll when jumping in low gravity.

**Weapon Attacks:** Add a +1 to-hit modifier to all direct-fire ballistic and missile weapon attacks for every .2 G (or fraction thereof) above or below the Terran standard 1 G.

## Meteor Showers

Meteor showers that actually affect a ground battle are rare in the extreme, but may occur on worlds with little to no atmosphere to burn up inbound debris from space or where the rocks that do fall are large enough to survive re-entry.

To simulate a meteor shower, players take turns rolling 1D6 during the End Phase of each turn. The result is the number of impacts that will occur at the end of the Movement Phase in the following turn. Impacts occur at random locations on the map, and deliver 3D6 damage points to any units in the hex of impact (delivered in 5-point clusters across the affected unit's Front facing). Double this damage if the unit consists of infantry or battle armor, or is a Support Vehicle with a BAR Rating of less than 10.

If there is an airborne non-aerospace unit in the target hex, it may be hit by falling debris (instead of any ground units) on a 2D6 roll of 10+. If so, in the case of VTOLs, Rotor location damage automatically destroys the unit's rotor mechanism and results in a crash.

**Terrain Factor/Construction Factor:** If using the Terrain Factor rules (see p. 64), planetary conditions take damage as though they were a battlefield unit; any hex with a planetary condition that does not have a Terrain Factor is converted into a rough hex, with the exception of water.

## Tainted and Toxic Atmospheres

Many worlds in the *BattleTech* universe where warriors are often called upon to fight do not possess the same concentrations of elements in their atmospheres as Terra does. Taints and toxins, such as elevated carbon dioxide, unsafe oxygen levels, leftover nuclear fallout and residue from biochemical weapons have left many planetary atmospheres unsafe for continued exposure. To rate these hazards, many worlds are described as having a breathable atmosphere, a tainted atmosphere or a toxic one. Breathable atmospheres, while they may smell a bit different from Terran standard or have slightly different levels of various chemicals, are safe enough for prolonged exposure and have no additional effect in game play.

Tainted atmospheres require special safeguards, and may yield unpredictable side effects when weapons begin blazing. Toxic atmospheres, where the taints are so excessive that only full environmental sealing can negate their effects on personnel, may eliminate the availability of some military units (most commonly infantry), forcing commanders to adapt their tactics accordingly.

The exact natures of various taints and toxins are many and varied, but for simplicity's sake, the most common atmospheric taints fall into three broad categories: caustic (corrosive or burning to organic tissues), radiological/poisonous (atmospheres that

## TAINED AND TOXIC ATMOSPHERES TABLE

Atmosphere Type	Effects
Breathable	No effects
Caustic	<p><b>Tainted:</b> All conventional infantry must be XCT Troops (see p. 351), and any weapon attack against them deals an additional 1D6 damage points (the damage is applied as though it originated from another infantry unit). Vehicles whose armor is breached suffer a Crew Stunned result. 'Mech or aerospace fighter pilots suffer one extra warrior hit if the Cockpit/Crew location takes damage in combat.</p> <p><b>Toxic:</b> Conventional infantry, and vehicles that do not contain the Environmentally Sealed Chassis and Controls modification, may not be fielded. Vehicle hull breaches or cockpit armor breaches in 'Mechs instantly kill vehicle crews and MechWarriors. Battle armor troopers whose suits take damage are considered destroyed on a separate 2D6 roll of 9+ (10+ for Harjel-equipped suits), even if they have armor remaining.</p>
Radiological/ Poisonous	<p><b>Tainted:</b> All conventional infantry must be XCT Troops (see p. 351). They take double damage in combat and cannot remain in the field outside a fortress or Castles Brian building hex or vehicle with the Environmental Sealing Chassis and Controls modification for more than 30 turns before suffering 1D6 damage per round thereafter (the damage is applied as though it originated from another infantry unit). Vehicles that do not have the Environmental Sealing Chassis and Controls modification cannot remain in the field for more than 90 turns before suffering a Crew Killed result.</p> <p><b>Toxic:</b> Conventional infantry, and vehicles that do not contain the Environmentally Sealed Chassis and Controls modification, may not be fielded. Breaches of vehicle armor or cockpits instantly kill vehicle crews and MechWarriors. Battle armor troopers are killed on a separate 2D6 roll of 9+ (10+ for Harjel-equipped suits) after any damaging hit in combat.</p>
Flammable	<p><b>Tainted:</b> Increase rolls to determine the likelihood of starting fires by 2, and players must make checks for starting accidental fires when making weapon attacks against any non-water hex. Heat-tracking units that are at 15 or higher heat may spontaneously ignite the hex they are standing in on a 2D6 result of 10+ during the End Phase of the current turn. Aerospace fighters, DropShips, Small Craft and other jet-propelled craft may ignite all hexes in their rear arc, out to a distance of 2 hexes, upon takeoff or landing; the 2D6 roll is made at the start of takeoff, or the end of landing, and a fire starts on a result of 6+. Jump jets may ignite the liftoff and landing hexes on a 2D6 result of 7+ (infantry expending Jumping MP ignite the hex on a 9+). Weapon attacks against conventional infantry are considered to be two types better (to a maximum of the area-effect weapon); for example, a Cluster (Missile) attack would be considered an area-effect attack for purposes of assigning damage (see the Non-Infantry Weapon Damage Against Infantry Table, p. 216, <i>TW</i>).</p> <p><b>Toxic:</b> Increase rolls to determine the likelihood of starting fires by 4, and players must make checks for starting accidental fires when making weapon attacks against any non-water hex. Fires caused by inferno rounds and explosive ordnance (such as AC rounds and missiles) instantly spread to all adjacent hexes. Aerospace and other jet-propelled units may not launch in lower atmosphere. Jump jets instantly create a fire hex at the point of liftoff and landing. Non-infantry weapon attacks against conventional infantry are treated as though the attacks originated from another infantry unit (see <i>Damage From Other Infantry Units</i>, p. 216, <i>TW</i>).</p>

human respiratory systems cannot metabolize, or rendered such by natural or manmade poisons and nuclear fallout) and flammable (atmospheres that either naturally or artificially are more conducive to starting or spreading fires). The Tainted and Toxic Atmospheres Table on the previous page outlines the effects of these categories in *Classic BattleTech* combat.

## WEATHER CONDITIONS

Weather conditions—like terrain conditions—represent global situations that apply to an entire playing area. This includes such situations as fighting at night, or on a world where the lighting is ultra bright.

As noted previously, modifiers and unit prohibitions imposed by weather conditions are added to modifiers and unit prohibitions imposed by the underlying base terrain type, terrain modifications and terrain conditions.

The following entries describe rules for weather conditions. They are organized by general category, with varying degrees of conditions for each type: fog, hail, light, rain, snow, wind and finally miscellaneous.

**Searchlights:** As various weather conditions deal with fighting in some type of darkness, it is appropriate to address searchlights here.

Units equipped with searchlights may turn their searchlights on (or off) during the Movement Phase. A searchlight illuminates all units in a target hex in its LOS—in the arc where the searchlight is mounted—during any Weapon or Physical attack phase. A searchlight also illuminates all intervening hexes (and hence all units in those hexes) between the target hex illuminated and the searchlight-equipped attacker. Hand-held searchlights only reach 10 hexes, while mounted searchlights reach 30 hexes. Regardless of whether the searchlight is hand-held or mounted, the attacking unit also illuminates itself.

Units attacking illuminated units change the modifiers for attacking in night-time conditions, based on the specific weather condition in use: *Full Moon Night* (see p. 58), *Moonless Night* (see p. 58), and *Pitch Black* (see p. 58).

If all players agree—or the scenario designates appropriately—'Mechs and Combat Vehicles that do not have searchlights can be nominated to carry a mounted searchlight for the duration of the scenario (hand-held searchlights cannot be nominated in this fashion).

Each time such a designated, searchlight-equipped 'Mech takes a hit in any torso location (Front or Rear), or when a searchlight-equipped Combat Vehicle takes a hit to the Front or Side, the player must roll 2D6 to determine if the searchlight is destroyed. A result of 7+ means the searchlight is destroyed, in addition to the normal effects of the attack.

Finally, the controlling player can turn the searchlight off or on during any End Phase of a turn; if it is on, he can turn it off, if off, he can turn it on.

**Wind:** Use the following rules when using any type of wind conditions in a game.

- **Wind Direction:** In a game that will include any type of wind condition (Light Gale, Moderate Gale, Strong Gale, Storm, Tornado F1–F3 or Tornado F4+), the players must determine wind direction. At the beginning of a given scenario, declare one side of a hex on the playing area to be Direction 1 and then number the remaining hexsides as 2 through 6, moving clockwise. Roll 1D6. For the entire

game, the wind will blow in the direction indicated by the die roll result.

- **Shifting Winds:** If players wish, they can add further diversity to their use of wind conditions in a given scenario, by having the direction and strength of the wind shift from turn to turn. During the End Phase of each turn, check to see if the direction or strength of the wind has changed. First roll 1D6 for wind strength. On a result of 1, the wind becomes one category weaker (for example, a Strong Gale would become a Moderate Gale). On a result of 6, it becomes one category stronger (for example a Storm would become a Tornado F1–F3). Then roll 1D6 for direction. On a result of 1, the wind direction changes by one hexside (60 degrees) clockwise. On a result of 6, the direction changes one hexside counterclockwise. A result of 2–5 on either roll indicates no change.

## FOG

### LIGHT FOG

If a scenario takes place under such conditions, modify movement and combat as follows.

**All Units:** Apply a +1 MP cost to enter each hex. For additional light fog rules, see *Careful Movement*, p. 62.

**Prohibited Conditions:** Cannot be used with Thin, Trace or Vacuum Atmospheric Pressures.

### HEAVY FOG

If a scenario takes place under such conditions, modify movement and combat as follows.

**All Units:** Apply a +2 MP cost to enter each hex and a +1 to-hit modifier to all direct-fire and pulse energy weapon attacks. For additional heavy fog rules, see *Careful Movement*, p. 62.

**Prohibited Conditions:** Cannot be used with Thin, Trace or Vacuum Atmospheric Pressures.

## HAIL

### LIGHT HAIL

If a scenario takes place under such conditions, modify movement and combat as follows.

**Conventional Infantry and Airships:** During the End Phase, each player rolls 1D6 if he or she controls any conventional infantry or Airships. The result is the number of conventional infantry and/or Airships that are damaged by the light hail; if the result is more than the number of such units a player controls, ignore the excess. Randomly determine the units affected and then roll 1D6/2 separately for each unit and apply that amount of damage as a single Damage Value grouping to the appropriate units, in a randomly determined location; for conventional infantry units, this damage is applied as though the attack originated from another infantry unit.

**Moderate Gale:** Light hail automatically includes all modifiers and effects of a Moderate Gale (see p. 61). If players are using the Shifting Winds rules (see p. 57) and the wind shifts to a Light Gale, the effects for light hail are lost, until the winds shift back to a Moderate Gale. Even if the wind shifts above a Moderate Gale, the effects of light hail remain constant.



INTRODUCTION

ADVANCED  
GROUND MOVEMENT

ADVANCED  
COMBAT

ADVANCED  
BUILDINGS

ADVANCED  
SUPPORT  
VEHICLES

GENERAL  
RULES

ADVANCED  
SUPPORT VEHICLE  
CONSTRUCTION

ADVANCED  
WEAPONS  
AND EQUIPMENT

INDEX

RECORD SHEETS



**Extreme Temperature:** Light hail automatically includes all modifiers and effects of -40 degrees Celsius (see p. 62).

**Prohibited Conditions:** Cannot be used with Thin, Trace or Vacuum Atmospheric Pressures, or with Extreme Temperatures of 30 degrees Celsius and above.

### HEAVY HAIL

If a scenario takes place under such conditions, modify movement and combat as follows.

**All Units:** During the End Phase, each player rolls 1D6. The result is the number of each player's units that take damage from the heavy hail; if the result is more than the number of units a player controls, ignore the excess. Randomly determine the units affected and then roll 1D6 separately for each unit and apply that amount of damage as a single Damage Value grouping to the appropriate units, in a randomly determined direction of attack and location. For battle armor, the damage is applied to a single trooper, with any excess damage lost; for Airships and conventional infantry units, double the damage (damage is applied to the conventional infantry as though the attack originated from another infantry unit).

**Strong Gale:** Heavy hail automatically includes all modifiers and effects of a Strong Gale (see p. 61). If players are using the Shifting Winds rules (see p. 57) and the wind shifts to a Moderate or Light Gale, the heavy hail becomes light hail, until the winds shift back to a Strong Gale. Even if the wind shifts above a Strong Gale, the effects of heavy hail remain constant.

**Extreme Temperature:** Heavy hail automatically includes all modifiers and effects of -40 degrees Celsius (see p. 62).

**Prohibited Conditions:** Cannot be used with Thin, Trace or Vacuum Atmospheric Pressures, or with Extreme Temperatures of 30 degrees Celsius and above.



*A Roughriders' Cerberus stumbles into the spotlights of a picket force lying in wait.*

## LIGHT

### DUSK/DAWN

If a scenario takes place under such conditions, modify combat as follows.

**All Units:** Apply a +1 to-hit modifier to all weapon attacks.

**Heat:** For every 25 points of heat on a target unit that tracks heat, apply a -1 to-hit modifier to any weapon attacks; conventional infantry ignore this modifier.

**Searchlights:** Searchlight-equipped units do not offset these penalties.

### FULL MOON NIGHT/GLARE

If a scenario takes place under such conditions, modify movement and combat as follows.

**All Units:** Apply a +2 to-hit modifier to all weapon attacks.

**Heat:** For every 20 points of heat on a target unit that tracks heat, apply a -1 to-hit modifier to any weapon attacks; conventional infantry ignore this modifier.

**Searchlights (only applies to Full Moon Night):** Units equipped with an active searchlight eliminate the +2 to-hit modifier within the arc and range of their searchlight; attacks against units equipped with an active searchlight eliminate this modifier as well.

### MOONLESS NIGHT/SOLAR FLARE

If a scenario takes place under such conditions, modify movement and combat as follows.

**All Units:** Apply a +3 to-hit modifier to all weapon attacks, while applying a +1 to-hit modifier to all physical attacks.

Apply a +1 modifier to any Piloting/Driving Skill Rolls (and Control Rolls) made if a unit used Running (Sprinting) or Flanking (Overdrive) movement, or used Maximum Thrust that turn.

**Heat:** For every 15 points of heat on a target unit that tracks heat, apply a -1 to-hit modifier to any weapon attacks; conventional infantry ignore this modifier.

**Searchlights (only applies to Moonless Night):** Units equipped with an active searchlight eliminate the +3 to-hit modifier within the arc and range of their searchlight (physical attacks within the arc of the searchlight eliminate the +1 modifier); any weapon or physical attacks against units equipped with an active searchlight eliminate this modifier as well.

### PITCH BLACK

This weather condition refers to a region of the Inner Sphere or Deep Periphery that is sparsely populated by star systems, or some other astronomical/atmospheric condition (such as a heavy asteroid field) that completely eliminates all light, including starlight.

If a scenario takes place under such conditions, modify movement and combat as follows.

**All Units:** Apply a +4 to-hit modifier to all weapon attacks and a +2 to-hit modifier to all physical attacks.

Apply a +2 modifier to any Piloting/Driving Skill Rolls (and Control Rolls) made if a unit used Running (Sprinting) or Flanking (Overdrive) movement, or used Maximum Thrust that turn.

**Heat:** For every 10 points of heat on a target unit that tracks heat, apply a -1 to-hit modifier to any weapon attacks; conventional infantry ignore this modifier.



**Searchlights:** Units equipped with an active searchlight modify the +4 to-hit modifier to a +1 modifier within the arc and range of their searchlight (physical attacks within the arc of the searchlight eliminate the +2 modifier); any weapon or physical attacks against units equipped with an active searchlight reduce the weapon attack modifier to +1, while completely eliminating the physical attack modifiers.

## RAIN

### LIGHT RAINFALL

If a scenario takes place under such conditions, modify movement and combat as follows.

**Conventional Infantry:** Apply a +1 to-hit modifier to all attacks.

**Prohibited Conditions:** Cannot be used with Thin, Trace or Vacuum Atmospheric Pressures.

### MODERATE RAINFALL

If a scenario takes place under such conditions, modify movement and combat as follows.

**All Units:** Apply a +1 to-hit modifier to all weapon attacks.

**Mud:** Moderate rainfall automatically includes all modifiers and effects of mud (see p. 50) in any clear, Depth 0 water or dirt road hex on the playing area.

**Prohibited Conditions:** Cannot be used with Thin, Trace or Vacuum Atmospheric Pressures.

### LIGHTNING STORM

If a scenario takes place under such conditions, modify movement and combat as follows.

During the End Phase of every turn, roll 1D6. On a result of 1–4, nothing happens. On a result of 5–6, roll 1D6 again, dividing the result by 2 (round down, to a minimum of 1). This new result indicates the number of lightning bolts that have struck the ground. Finally, players should roll on the Lightning Bolt Table to determine the strength of each lightning bolt.

Once the type of lightning bolt has been determined, using any manner that the players agree on, randomly determine the hexes where the lightning strikes. All units within that hex take damage. This damage is applied as a single Damage Value grouping from a single attack from a randomly determined direction, to a single location (for units with locations). For conventional infantry, the attack is resolved as though it originated from another infantry unit.

**Terrain Factor:** If players are using the Terrain Factor Rules (see p. 64), the damage from this attack is applied to all ter-

rain conditions as appropriate; remember to scale damage for building hexes, as appropriate (see *Scaled Damage*, p. 126).

**Moderate Rainfall:** A lightning storm automatically includes all modifiers and effects of moderate rainfall (at left).

**Moderate Gale:** A lightning storm automatically includes all modifiers and effects of a Moderate Gale (see p. 61).

**Prohibited Conditions:** Cannot be used with Thin, Trace or Vacuum Atmospheric Pressures.

### HEAVY RAINFALL

If a scenario takes place under such conditions, modify movement and combat as follows.

**All Units:** Apply a +1 to-hit modifier to all weapon attacks and a +1 Piloting/Driving Skill Roll modifier (this includes Control Rolls).

**Mud:** Heavy rainfall automatically includes all modifiers and effects for mud (see p. 50); mud occurs in every hex across the playing area (except for water hexes of Depth 1+, standard roads and building hexes).

**Rapids:** Heavy rainfall automatically includes all modifiers and effects for rapids (see p. 50) for any Depth 1 or deeper water hexes on the playing area.

**Prohibited Conditions:** Cannot be used with Thin, Trace or Vacuum Atmospheric Pressures.

### GUSTING RAIN

If a scenario takes place under such conditions, modify movement and combat as follows.

**Heavy Rainfall:** Gusting rain automatically includes all modifiers and effects of heavy rainfall (above).

**Strong Gale:** Gusting rain automatically includes all modifiers and effects for a Strong Gale (see p. 61).

**Prohibited Conditions:** Cannot be used with Thin, Trace or Vacuum Atmospheric Pressures.

### TORRENTIAL DOWNPOUR

If a scenario takes place under such conditions, modify movement and combat as follows.

**All Units:** Apply a +2 to-hit modifier to all weapon attacks and a +2 modifier to all Piloting/Driving Skill and Control rolls.

**Mud:** A torrential downpour automatically includes all modifiers and effects of mud (see p. 50); mud occurs in every hex across the playing area except for water hexes of Depth 1+, standard roads and building hexes. Additionally, all Depth 0 water hexes become swamp hexes (see p. 51).

**Torrent:** A torrential downpour automatically includes all modifiers and effects of torrents (see p. 52) for any Depth 1 or deeper water hexes on the playing area.

**Prohibited Conditions:** Cannot be used with Thin, Trace or Vacuum Atmospheric Pressures.

## LIGHTNING BOLT TABLE

1 D6 Roll	Damage Value	Number of hexes affected
1–3	5	1
4–5	10	1
6	15	7*

\*15 points of damage are applied to all units in the central hex, while 5 points are applied to all units in adjacent hexes.

INTRODUCTION

ADVANCED  
GROUND MOVEMENT

ADVANCED  
COMBAT

ADVANCED  
BUILDINGS

ADVANCED  
SUPPORT  
VEHICLES

GENERAL  
RULES

ADVANCED  
SUPPORT VEHICLE  
CONSTRUCTION

ADVANCED  
WEAPONS  
AND EQUIPMENT

INDEX

RECORD SHEETS



## SNOW

### LIGHT SNOWFALL

If a scenario takes place under such conditions, modify movement and combat as follows.

**Conventional Infantry:** Apply a +1 to-hit modifier to all conventional infantry.

**Extreme Temperature:** Light snowfall automatically includes all modifiers and effects of -40 degrees Celsius (see p. 62).

**Prohibited Conditions:** Cannot be used with Thin, Trace or Vacuum Atmospheric Pressures.

### MODERATE SNOWFALL

If a scenario takes place under such conditions, modify movement and combat as follows.

**All Units:** Apply a +1 to-hit modifier to all weapon attacks.

**Extreme Temperature:** Light snowfall automatically includes all modifiers and effects of -50 degrees Celsius (see p. 62).

**Thin/Deep Snow:** At the start of Turn 10 of a scenario (provided a scenario lasts long enough), heavy snowfall includes all modifiers and effects of thin snow (see p. 52). At the start of Turn 20 of a scenario (provided a scenario lasts long enough), heavy snowfall includes all modifiers and effects of deep snow (see p. 41). In both instances, thin/deep snow occurs in every hex across the playing area (this includes the tops of buildings, but not water hexes, unless they are frozen over).

**Ice:** At the start of Turn 20 of a scenario (provided the scenario lasts long enough), heavy snowfall includes all modifiers and effects of ice (see p. 50); ice occurs in every water hex across the playing area.

**Prohibited Conditions:** Cannot be used with Thin, Trace or Vacuum Atmospheric Pressures, or with Extreme Temperatures of 30 degrees Celsius and above.

### SLEET

If a scenario takes place under such conditions, modify movement and combat as follows.

**All Units:** Apply a +1 to-hit modifier to all weapon attacks.

**Moderate Gale:** Sleet automatically includes all modifiers and effects of a Moderate Gale (see p. 61). If players are using the Shifting Winds rules (see p. 57) and the wind shifts to a Light Gale, the effects for sleet are lost, until the winds shift back to a Moderate Gale. If the wind shifts above a Moderate Gale, however, the effects of sleet remain constant.

**Ice:** At the start of Turn 15 of a scenario (provided the scenario lasts long enough), sleet includes all modifiers and effects of ice (see p. 50); ice occurs in every water hex across the playing area.

**Extreme Temperature:** Sleet automatically includes all modifiers and effects of -40 degrees Celsius (see p. 62).

**Prohibited Conditions:** Cannot be used with Thin, Trace or Vacuum Atmospheric Pressures, or with Extreme Temperatures of 30 degrees Celsius and above.

### SNOW FLURRIES

If a scenario takes place under such conditions, modify movement and combat as follows.

**Moderate Snowfall:** Snow flurries automatically includes all modifiers and effects of moderate snowfall (at left).

**Moderate Gale:** Snow flurries automatically includes all modifiers and effects of a Moderate Gale (see p. 61).

**Prohibited Conditions:** Cannot be used with Thin, Trace or Vacuum Atmospheric Pressures, or with Extreme Temperatures of 30 degrees Celsius and above.

### HEAVY SNOWFALL

If a scenario takes place under such conditions, modify movement and combat as follows.

**All Units:** Apply a +1 to-hit modifier to all weapon attacks and a +1 modifier to all Piloting/Driving Skill Rolls (this includes Control Rolls).

**Thin/Deep Snow:** At the start of Turn 5 of a scenario (provided a scenario lasts long enough), heavy snowfall includes all modifiers and effects of thin snow (see p. 52). At the start of Turn 15 of a scenario (provided a scenario lasts long enough), heavy snowfall includes all modifiers and effects of deep snow (see p. 41). In both instances, thin/deep snow occurs in every hex across the playing area (this includes the tops of buildings, but not water hexes, unless they are frozen over).

**Ice:** At the start of Turn 20 of a scenario (provided the scenario lasts long enough), heavy snowfall includes all modifiers and effects for ice (see p. 50); ice occurs in every water hex across the playing area.

**Extreme Temperature:** Heavy snowfall automatically includes all modifiers and effects of -50 degrees Celsius (see p. 62).

**Prohibited Conditions:** Cannot be used with Thin, Trace or Vacuum Atmospheric Pressures, or with Extreme Temperatures of 30 degrees Celsius and above.

### ICE STORM

If a scenario takes place under such conditions, modify movement and combat as follows.

**Black Ice:** An ice storm automatically includes all modifiers and effects of black ice (see p. 40).

**Extreme Temperature:** An ice storm automatically includes all modifiers and effects of -60 degrees Celsius (see p. 62).

**Ice:** At the start of Turn 10 of a scenario (provided the scenario lasts long enough), an ice storm includes all modifiers and effects of ice (see p. 50); ice occurs in every water hex across the playing area.

**Moderate Gale:** An ice storm automatically includes all modifiers and effects for a Moderate Gale (see p. 61).

**Prohibited Conditions:** Cannot be used with Thin, Trace or Vacuum Atmospheric Pressures, or with Extreme Temperatures of 30 degrees Celsius and above.

### BLIZZARD

If a scenario takes place under such conditions, modify movement and combat as follows.

**Heavy Snowfall:** A blizzard automatically includes all modifiers and effects of heavy snowfall (see *Heavy Snowfall*, above).

**Strong Gale:** A blizzard automatically includes all modifiers and effects of a Strong Gale (see p. 61).

**Prohibited Conditions:** Cannot be used with Thin, Trace or Vacuum Atmospheric Pressures, or with Extreme Temperatures of 30 degrees Celsius and above.



## WIND

### LIGHT GALE

If a scenario takes place under such conditions, modify movement as follows.

**Airships:** Apply a +1 modifier to all Control Rolls.

**Conventional Infantry:** Apply -1 Ground MP to all foot conventional infantry, to a minimum of 0; any units reduced to 0 MP can either move or make a weapon attack in a turn, but not both (see p. 213, *TW*).

**Prohibited Conditions:** Cannot be used with Trace or Vacuum Atmospheric Pressures.

### MODERATE GALE

If a scenario takes place under such conditions, modify movement and combat as follows.

**All Units:** Apply a +1 to-hit modifier to all missile weapon attacks.

**Airships:** Apply a +2 modifier to all Control Rolls.

**WiGE, VTOL:** Apply a +1 modifier to all Piloting Skill Rolls.

**Conventional Infantry:** Apply -1 MP to both Ground and Jumping movement to all conventional infantry, to a minimum of 0; any units reduced to 0 MP can either move or make a weapon attack in a turn, but not both (see p. 213, *TW*).

**Prohibited Conditions:** Cannot be used with Vacuum Atmospheric Pressures.

### STRONG GALE

If a scenario takes place under such conditions, modify movement and combat as follows.

**All Units:** Apply a +2 to-hit modifier to all missile weapon attacks and a +1 to-hit modifier to all direct-fire ballistic weapon attacks.

**'Mechs:** Apply a +1 modifier to all Piloting Skill Rolls.

**Airships:** Apply a -1 modifier to Safe Thrust and a +3 modifier to all Control Rolls.

**Hover, WiGE, VTOL:** Apply a +2 modifier to all Driving Skill Rolls.

**Aerospace Units (excepting Airships):** Apply a +1 modifier to all Control Rolls.

**Battle Armor:** Apply -1 Ground MP, to a minimum of 0; any such units can either move or make a weapon attack in a turn, but not both (see p. 213, *TW*).

**Conventional Infantry:** Apply -2 Ground MP to all conventional infantry, to a minimum of 0; any units reduced to 0 MP can either move or make a weapon attack in a turn, but not both (see p. 213, *TW*). No jumping movement is allowed.

**Water Hexes:** All water hexes contain the Rapids terrain modification (see p. 50).

**Terrain/Construction Factor:** If using the Terrain Factor Rules (see p. 64), during the End Phase of every turn, apply 10 points of damage to every base terrain type that lists a TF (CF in the case of buildings) value greater than 0 on the Expanded Movement Costs and Planetary Conditions Tables (see p. 126).

In the case of building hexes, this damage is scaled, depending on the building classification (see *Scaled Damage*, p. 32).

**Prohibited Conditions:** Cannot be used with Vacuum Atmospheric Pressures.

### STORM

If a scenario takes place under such conditions, modify movement and combat as follows.

**All Units:** Apply a +3 to-hit modifier to all missile weapon attacks and a +2 to-hit modifier to all direct-fire ballistic weapon attacks.

**'Mechs:** Apply a +3 modifier to all Piloting Skill Rolls.

**Hover, WiGE, VTOL:** Apply a +3 modifier to all Driving Skill Rolls.

**Aerospace Units (excepting Airships):** Apply a +2 modifier to all Control Rolls.

**Battle Armor:** Apply -1 MP to Ground movement, to a minimum of 0; any such units can either move or make a weapon attack in a turn, but not both (see p. 213, *TW*). No jumping movement is allowed.

**Airships and Conventional infantry:** These units cannot operate in storm conditions.

**Water Hexes:** All water hexes contain the Rapids terrain modification (see p. 50).

**Terrain/Construction Factor:** If using the Terrain Factor Rules (see p. 64), during the End Phase of every turn, apply 20 points of damage to every base terrain type that lists a TF (CF in the case of buildings) value greater than 0 on the Expanded Movement Costs and Planetary Conditions Tables (see p. 32).

In the case of building hexes, this damage is scaled, depending on the building classification (see *Scaled Damage*, p. 126).

**Prohibited Conditions:** Cannot be used with Vacuum Atmospheric Pressures.

### TORNADO F1-F3

If a scenario takes place under such conditions, modify movement and combat as follows.

**All Units:** Apply a +3 to-hit modifier to all direct-fire ballistic weapon attacks and a +2 to-hit modifier to all direct-fire and pulse energy weapon attacks; missile weapon attacks cannot be made.

Apply -2 Walking/Cruising MP and a +3 modifier to all Piloting/Driving Skill Rolls.



*Whipped by a growing storm, fog envelopes these Pleiades Hussars 'Mechs.*

INTRODUCTION

ADVANCED  
GROUND MOVEMENT

ADVANCED  
COMBAT

ADVANCED  
BUILDINGS

ADVANCED  
SUPPORT  
VEHICLES

GENERAL  
RULES

ADVANCED  
SUPPORT VEHICLE  
CONSTRUCTION

ADVANCED  
WEAPONS  
AND EQUIPMENT

INDEX

RECORD SHEETS



**Aerospace Units (excepting Airships):** Apply -1 Safe Thrust MP and a +3 modifier to all Control Rolls.

**Hover, VTOL, WiGE, Airship and Infantry Units:** These units cannot operate in Tornado F1-F3 conditions.

**Terrain/Construction Factor:** If using the Terrain Factor Rules (see p. 64), during the End Phase of every turn, apply 40 points of damage to every base terrain type that lists a TF (CF in the case of buildings) value greater than 0 on the Expanded Movement Costs and Planetary Conditions Tables (see p. 32).

In the case of building hexes, this damage is scaled, depending on the building classification (see *Scaled Damage*, p. 126).

**Water Hexes:** All water hexes contain the Torrent terrain modification (see p. 52).

**Prohibited Conditions:** Cannot be used with Vacuum Atmospheric Pressures.

### TORNADO F4+

If a scenario takes place under such conditions, modify movement and combat as follows.

**'Mechs:** 'Mechs cawing Skill Rolls. Only direct-fire and pulse energy weapons can be used, but apply a +3 to-hit modifier.

**Non-'Mech Units:** These units cannot operate in Tornado F4+ conditions.

**Water Hexes:** All water hexes contain the Torrent terrain modification (see p. 52).

**Terrain/Construction Factor:** If using the Terrain Factor Rules (see p. 64), during the End Phase of every turn, apply 80 points of damage to every base terrain type that lists a TF (CF in the case of buildings) value greater than 0 on the Expanded Movement Costs and Planetary Conditions Table (see p. 32).

In the case of building hexes, this damage is scaled, depending on the building classification (see *Scaled Damage*, p. 126).

**Prohibited Conditions:** Cannot be used with Vacuum Atmospheric Pressures.

## MISC.

### BLOWING SAND

If a scenario takes place under such conditions, modify movement and combat as follows.

**All Units:** Apply a +1 to-hit modifier to all direct-fire and pulse energy weapon attacks.

**WiGE/VTOL Vehicles:** During the End Phase, each player rolls 1D6 if he controls any WiGE or VTOL vehicles that were airborne that turn. The result is the number of units damaged by the blowing sand; if the result is more than the number of such units a player controls, simply ignore the excess. Randomly determine the WiGE/VTOL vehicles affected; then roll 1D6 and divide by 2 (to a minimum of 1) separately for each unit and apply that amount of damage as 1-point Damage Value groupings to the appropriate units, in a randomly determined direction of attack and location for each point of damage.

**Moderate Gale:** Blowing sand automatically includes all modifiers and effects of a Strong Gale (see p. 61). If players are using the Shifting Winds rules (see p. 57) and the wind shifts to a Light Gale, the effects for blowing sand are lost, until the winds shift back to a Moderate Gale. For each level of wind condition above Moderate Gale, increase the damage to WiGE/VTOL vehicles by 1 point.

### EXTREME TEMPERATURES

If a scenario takes place under such conditions, modify movement and combat as follows.

For combat in temperatures between -30 and 50 degrees Celsius (-22 degrees and 122 degrees Fahrenheit), the environmental conditions have no impact on a game of *Classic BattleTech*. However, fighting in significantly higher or lower temperatures affects how well units dissipate heat and degrades the combat effectiveness of other units.

For all units that track heat, for each 10 degrees C (or fraction thereof) higher than 50 degrees, add 1 Heat Point to the unit's overall heat buildup each turn. For every 10 degrees C (or fraction thereof) less than -30 degrees, subtract 1 Heat Point from the unit's overall heat build-up each turn.

**Vehicles:** For vehicles, for each 10 degrees C (or fraction thereof) higher than 50 degrees, reduce their Cruising speed by 1 Movement Point. For every 10 degrees C (or fraction thereof) less than -30 degrees, reduce their Cruising speed by 1 Movement Point. Recalculate Flanking speed based on the new Cruising speed.

**Infantry:** Extreme temperatures affect infantry in the same way as vehicles, slowing their movement. However, conventional infantry platoons cannot be deployed outside a vehicle or building in temperatures that exceed 50 degrees C or are less than -30 degrees C, unless they are XCT troops (see p. 351), in which case they ignore such movement restrictions.

**ProtoMechs:** ProtoMechs are affected by extreme temperatures as for vehicles.

### BOG DOWN RULES

Some planetary conditions may actually stick a unit in place, as noted in the description of such conditions.

Any time a unit enters a hex that may cause it to get stuck, the controlling player must make a Piloting/Driving Skill Roll. If the roll fails, the unit gets stuck in the hex and may not move for the rest of the turn; a 'Mech that fails this roll does not fall. The unit may torso twist or rotate its turret normally, but it may not change its facing. For any weapon or physical attacks made against a unit stuck in a hex, modify the to-hit number by -2.

At the start of the next turn's Movement Phase, the player controlling a stuck unit makes a Piloting/Driving Skill Roll. On a successful roll, the unit breaks away from the planetary condition in the hex and may move normally. If the roll fails, the unit remains stuck (but does not fall in the case of 'Mechs) and makes another Piloting/Driving Skill Roll at the start of the next Movement Phase.

Jump-capable units that use Walking or Running movement to enter tundra, magma, deep snow or mud may get stuck, but such units can free themselves in subsequent Movement Phases by simply jumping out of the terrain.

**Additional Modifiers:** For tundra, magma crust, deep snow and mud hexes, apply a -1 modifier to the Piloting Skill Roll to determine whether a unit entering such terrain gets stuck. Apply the same modifier to Piloting Skill Rolls made to free a stuck unit.

**Falling:** If a 'Mech falls in such a hex (for example, if it is forced to make a Piloting Skill Roll after being displaced), it automatically becomes stuck and its movement ends. The 'Mech must make three successful Piloting Skill Rolls to be free of the hex; the first to free itself from a stuck prone position, the second to stand up and the third to free itself from the hex completely.



INTRODUCTION

ADVANCED GROUND MOVEMENT

ADVANCED COMBAT

ADVANCED BUILDINGS

ADVANCED SUPPORT VEHICLES

GENERAL RULES

ADVANCED SUPPORT VEHICLE CONSTRUCTION

ADVANCED WEAPONS AND EQUIPMENT

INDEX

RECORD SHEETS



**Jumping:** A jumping 'Mech that lands in such a hex automatically gets stuck; jumping infantry are not automatically stuck, however.

**Infantry:** For infantry entering such a hex, roll 2D6. On a result of 4 or less, the unit gets stuck. To escape getting stuck, an infantry unit need only make a 2D6 roll of 4+.

**ProtoMechs:** For ProtoMechs entering such a hex, use the Gunnery Skill Rating when making Piloting Skill Rolls.

**Skidding:** A unit entering such a hex while skidding automatically gets stuck.

**Displacement**

Units that get stuck in a hex are still displaced under the Unit Displacement rules (see p. 151, TW); however, they will automatically fall in the hex into which they are displaced. If a unit is displaced into a hex where it can bog down, an immediate roll is made to see if the unit gets stuck in the new hex.

If a unit is displaced more than one hex in a single action and the first hex into which it is displaced has a planetary condition that requires a Bog Down Roll, the unit is not displaced any further if it gets stuck. The only exception to this rule is if a unit is displaced multiple hexes in a single action because each of the previous hexes is occupied by another unit (that is, if the unit was not displaced, it would violate stacking rules). In this case, no Bog Down Roll is made and the unit is displaced appropriately (though a Bog Down Roll is made in the final hex into which the unit is displaced, if appropriate).

*Using the Unit Displacement Diagram (see p. 153, TW), all hexes are mud and the 'Mech in Hex B is stuck. As 'Mech A falls into Hex B, it automatically gets stuck in the mud, which means that during the Movement Phase of the following turn, if the player wishes to move the unit, he must make three successful Piloting Skill Rolls. The 'Mech in Hex B, even though it is stuck, is still automatically displaced into Hex C. However, because it was stuck when it was displaced, it automatically falls in Hex C and will automatically get stuck in a prone position. If the 'Mech in Hex C has 2 MP left, it can attempt to move into Hex F, or if it has 1 MP left, it can attempt to move into Hex E; both require a Piloting Skill Roll to move into the hex, avoiding the domino effect, and then another Piloting Skill Roll to avoid getting stuck in either mud hex. If the 'Mech in Hex C does not have any MP left, it is automatically displaced into Hex D. It must then make a Piloting Skill Roll to avoid falling, and if successful, another Piloting Skill Roll to avoid getting stuck; if it fails the first roll and falls, it is automatically stuck.*

**CAREFUL MOVEMENT**

The increased MP cost of entering hexes enveloped by light or heavy fog or covered with ice represents the extra caution needed to avoid tripping, falling or crashing in such conditions. By paying the increased Movement cost, units can cross such dangerous terrain without mishap.

Alternatively, players who do not wish to pay this cost can announce their intention to pass through the terrain at full speed before moving their units. After the unit moves 1 hex, the player must make a Piloting/Driving Skill Roll.

If the unit is a 'Mech and the roll fails, the 'Mech immediately falls and must stand up per standard rules before continuing

its movement (if this fall occurs on pavement, the unit skids and its move is over). If the roll succeeds, the 'Mech remains upright and the unit may move per standard rules. However, the player must make an additional Piloting/Driving Skill Roll for each non-clear hex (unless there is ice in the clear hex) and level change through which the unit passes.

If the unit is a vehicle and the roll fails, the effects depend on the specific terrain and conditions. On icy terrain, the vehicle skids (see *Skidding*, p. 62, TW). Unless it is in Clear terrain, if the roll fails in fog, the vehicle crashes. In Clear terrain, the vehicle hits a hole or other minor obstruction that costs the unit 1 additional MP. In all other terrain, the crash ends the vehicle's movement, and the vehicle sustains damage to its Front side as if it had charged.

If both fog and ice are present, the modifiers are cumulative, because the fog's effect on visibility is assumed to present the greater obstacle to safe movement. All other standard rules for fog and ice apply, regardless of unit type (see pp. 57 and 50 respectively).

**EXPANDED HEAT POINT TABLE**

Activity	Heat Points
Walking	+1 per turn
Running	+2 per turn
Jumping	+1 per hex (minimum of 3 per turn)
Sprinting	+3 per turn
Attempting to stand	+1 per attempt
Weapons fire	Per Weapons and Equipment Tables, p. 303, TW and p. 404.
Heat-causing weapons	Per Weapons and Equipment Tables, p. 303, TW and p. 404.
Heat sink	-1 per operational heat sink
	-2 per operational double heat sink
	-1 additional per operational single heat sink under water (max. 6 points)
	-2 additional per operational double heat sink underwater (max. 6 points)
First engine hit	+5 per turn
Second engine hit	+10 (total) per turn
Low Temperature	-1 per turn per 10 degrees Celsius below -30 degrees Celsius
High Temperature	+1 per turn per 10 degrees Celsius above 30 degrees Celsius
Weather Conditions	See Weather Conditions Table, p. 36
Deep Snow	-1 per turn; for 'Mechs this only applies if a heat sink is mounted in the legs.
Fire/Magma Crust	+5 if occupied during Heat Phase
	+2 per each hex exited during Movement Phase
Magma Liquid	+10 if occupied during Heat Phase
	+5 per each hex exited during Movement Phase

**Hover and WiGE Vehicles:** Hover and WiGE vehicles ignore the effects of ice and do not need to expend Careful Movement when moving through such conditions.

**Terrain Factor:** Some units may expend an additional +1 MP for careful movement when entering a hex in order not to inflict movement damage against the planetary conditions in that hex. See *Careful Movement* under *Terrain Factor Rules*, p. 65.

## HEAT SCALE MODIFIERS

Different planetary conditions may also affect how quickly a unit that tracks heat generates internal heat. Though the rules for each planetary condition note whether they affect heat, for ease

of use, the Expanded Heat Point Table (see previous page) lists the number of Heat Points generated by all conditions, as well as the Heat Points generated by various activities and damage. (For a full description of heat rules, see pp. 158–161, *TW*.)

## TERRAIN FACTOR RULES

In standard rules *Classic BattleTech*, all terrain—with the exception of buildings—is considered indestructible for movement purposes. When it comes to combat, only the clearing of wooded terrain is addressed (see *Clearing Woods*, p. 112, *TW*). However, while simple and easy to use, such rules are far from realistic. Particularly with the introduction of some base terrain types and

## TERRAIN FACTOR AND CONVERSION TABLE

Table Key:

NLV: Non-Large Vehicles  
SSV: Small Support Vehicle  
LCV: Light Combat Vehicle  
PM: ProtoMechs

Terrain Factor	Former Terrain	New Terrain	Prohibited Units Movement Damage	Prohibited Units Combat Damage	Careful Movement
Ultra-Heavy Woods: 120	Ultra-Heavy Woods	Heavy Woods	Infantry	Infantry*	—
Heavy Woods: 90	Heavy Woods	Light Woods	Infantry	Infantry*	—
Light Woods: 50	Light Woods§§	Rough	Infantry, SSV, PM	Infantry*	NLV
Ultra-Heavy Jungle: 130	Ultra-Heavy Jungle	Heavy Jungle	Infantry	Infantry*	—
Heavy Jungle: 100	Heavy Jungle	Jungle	Infantry	Infantry*	—
Light Jungle: 60	Light Jungle§§	Rough	Infantry, SSV, PM	Infantry*	NLV
Gravel Piles: 100	Gravel Piles	Rough	Infantry	—	—
Magma Crust: 30	Magma Crust	Magma Liquid	‡	—	—
Planted Fields: 30	Planted Fields	Clear	—	—	Infantry, LCV, SSV
Sand: 100	Sand	Sand Sublevel 1§	—	Infantry*	—
Sheer Cliffs: 50	Sheer Cliffs	**	Infantry	—	SSV, PM
Tundra: 70	Tundra	Rough	Infantry	—	LCV, SSV, PM
Rail: 20	Rail	Clear	Infantry	—	LCV, SSV, PM
Dirt Road: 20	Dirt Road	‡‡	—	—	Infantry
Gravel Road: 50	Gravel Road	‡‡	Infantry	—	Infantry, LCV, SSV, PM
Paved Road: 150	Paved Road	‡‡	Infantry, SSV, PM	Infantry*	Infantry, Vehicles
Paved: 200	Paved	Rough	Infantry, NLV, PM	Infantry	Large Vehicles; Mechs
Deep Snow: 30	Deep Snow	Light Snow	—	—	Infantry
Light Snow: 15	Light Snow	Mud	—	—	Infantry
Ice: 40	Ice	††	—	—	Infantry, PM, Vehicles
Clear/Rough: 200	Clear/Rough	Rough Sublevel 1†	Infantry, SSV	Infantry*	All

\*Except for infantry with the Combat Engineer specialization (see p. 341).

†This also applies to any Clear Level terrain, so that Level 5 Clear terrain would now be Level 4 Rough.

‡See *Magma*, p. 36.

§If more than 50 points of damage dealt to the hex is done by direct-fire energy or pulse weapons, it becomes a Rough Sublevel 1.

§§If the hex started as ultra woods/jungle, it is reduced to ultra-rough.

\*\*Sheer cliffs are simply removed from the hexside, with no additional affects, or without leaving any other condition behind.

††If the underlying terrain is water, the hex is reduced to water; otherwise the condition is simply removed from the hex.

‡‡Each road, when reduced, becomes a rough road. This means all units pay an extra 1 MP to enter the hex, but it is still a road, and so a unit may pass through a hex with an underlying terrain that it may be prohibited from entering; all other benefits of the road are lost.



terrain modifications that can easily be damaged and/or destroyed by the movement of heavy machinery—much less the targeted impact of powerful weaponry—taking that factor into account conveys a more realistic game, while adding whole new levels of tactics.

With that in mind, the Terrain Factor rules build on the Terrain Factor concept originally described in *Clearing Woods* (see p. 112, *TW*), but greatly expands its usage.

The Terrain Factor (TF) determines the number of damage points a particular planetary condition in a specific hex can take before being reduced or eliminated; this damage, regardless of when it occurs, is tracked across a game until the TF is reduced to 0. Damage can occur from movement and/or combat (see *Movement Damage* and *Combat Damage*, below). Finally, in the specific case of some planetary conditions—noted on the Terrain Factor and Conversion Table—the TF also represents the number of tons of total weight that can occupy a given hex before the specific planetary condition's TF is automatically reduced to 0.

Though the TF of every planetary condition is found on the Expanded Movement Costs and Planetary Conditions Table (each TF is the rating per hex), those values are also listed on the Terrain Factor and Conversion Table below, for ease of comparison and use. The table also details whether a planetary condition is converted to another type of planetary condition as its TF is reduced and what it will ultimately be converted to once its TF is reduced to 0. Note that only those planetary conditions with a TF value higher than 0 are listed on the Terrain Factor and Conversion Table.

The introduction to planetary conditions mentions the added complexity of including such rules in a given scenario—a reality particularly worth repeating for the Terrain Factor rules. These rules provide a wonderful diversity, for the realistic element as well as the new and fun tactics that such “terrain destruction” allows. However, tracking damage across all the planetary conditions of an entire playing area can significantly increase the complexity of a game, as well as the length of time it will take to finish that game. As a way to mitigate such a factor, players can be selective, if they wish. For example, in a given scenario perhaps only terrain modifications can be reduced using these rules, while all other planetary conditions cannot. Regardless of whether a playing group is selective or plans to apply the Terrain Factor rules across the entire playing area, all players should be very familiar with these rules and willing to implement them in a given scenario before play begins.

**Current TF:** As with Construction Factor (see p. 155, *TW*), the current TF of a planetary condition in a specific hex is defined as the TF at the instant an action takes place. For example, if two 'Mechs enter the same hex with a planetary condition that has a TF above 0 at different times in the same Movement Phase, the current TF for both units may be different, if the first unit damaged the planetary condition's TF.

For those planetary conditions that can be reduced through different types of conditions—such as ultra-heavy woods, to heavy woods, to light woods, to rough hex—its type does not change until the TF falls below the value of the reduced hex as shown on the Terrain Factor column of the Terrain Factor and Conversion Table.

**Note:** A hex must be reduced to a rough/clear hex, with no terrain modifications left, before the hex itself can be dam-

aged. For example, an ultra-heavy jungle hex would need to have 130 points of damage applied to it, to reduce it to a rough hex, and then additional damage could be applied to that rough hex's Terrain Factor of 200.

### Movement Damage

Each time a unit enters a hex—depending on the unit type and the planetary condition in question—it can potentially damage the planetary condition(s) in that hex. If the Terrain Factor and Conversion Table indicates that a specific unit type entering a hex can damage a specific planetary condition in that hex, the player divides the weight of the unit by 10 (rounding up) and applies that value to the planetary condition, reducing its TF.

If more than one planetary condition exists in a hex, and the unit entering the hex can damage the TF of multiple planetary conditions, damage is applied to all appropriate conditions.

**Buildings:** While these rules are very similar to how building hexes resolve damage due to unit movement, players should refer to those specific rules when dealing with buildings (see pp. 166, *TW*, and 114).

**Falling Damage:** Damage inflicted from a fall is also inflicted against all the target planetary conditions and the hex. Determine the damage to the unit that has fallen and apply the same damage to the hex and the planetary conditions.

**Large Vehicles:** Double the damage applied to a planetary condition from a Large Vehicle.

**Infantry:** In the case of infantry, to determine the damage to the TF of planetary conditions in a hex, use the Tons of Cargo Space Occupied column of the Generic Conventional Infantry Units Table and Battle Armor Organization/Weight Table (see pp. 213 and 214, *TW*, respectively). If the Advanced Battle Armor Weights rules are in effect (see p. 186), use those weights instead.

**Non-DropShip Aerospace Units:** Non-Spheroid aerospace units taking off and landing do not determine damage for every hex they pass through. Instead, they only determine damage in the final hex or hexes they occupy at the end of landing, or the hex(s) where they began their takeoff.

**DropShips:** DropShips taking off and landing do not determine damage for every hex they pass through. Instead, they use the proximity damage from their fusion exhaust, determining damage not only for units, but for appropriate planetary conditions as well, applying said damage to appropriate Terrain Factors (see *Proximity Damage*, p. 88, *TW*). All planetary conditions in a hex—including roads, rails and so on—with a landing or taking-off Spheroid DropShip are automatically reduced to 0 TF.

**Mobile Structures:** A Mobile Structure automatically inflicts 150 points of damage to all terrain and terrain modifications within a hex it enters (see p. 165).

**Careful Movement:** Some units can use Careful Movement (see *Careful Movement*, p. 63) to avoid damaging a planetary condition's TF. The Terrain Factor and Conversion Table (see p. 64) notes which units can expend an extra 1 MP per hex to avoid dealing damage.

### Combat Damage

Units can use weapon attacks to reduce various planetary conditions, changing them from one type to another. As all such targets are immobile, apply a -4 to-hit modifier to any such attacks.

INTRODUCTION

ADVANCED  
GROUND MOVEMENT

ADVANCED  
COMBAT

ADVANCED  
BUILDINGS

ADVANCED  
SUPPORT  
VEHICLES

GENERAL  
RULES

ADVANCED  
SUPPORT VEHICLE  
CONSTRUCTION

ADVANCED  
WEAPONS  
AND EQUIPMENT

INDEX

RECORD SHEETS



Specifically targeting a planetary condition to reduce its TF requires a conscious effort. If an attack against a unit passes through or into such hexes, the attack does not reduce that planetary condition's TF (unless the rules for Woods Cover and Missed Shots are in use; see pp. 84 and 81, respectively).

**Prohibited Units:** Not all units can use attacks to reduce a given planetary condition's TF; the Terrain Factor and Conversion Table notes which units are prohibited from damaging which planetary conditions.

**Area-Effect Weapons:** Because area-effect weapons target the hex, such weapons always damage a planetary condition in a hex, regardless of whether or not the player made a conscious choice to strike the hex (for example, a bomb that scatters will still damage the TF of any planetary conditions in the hex); double the Damage Value of these weapons against all planetary conditions (except Clear/Rough terrain).

**Buildings:** These rules do not apply to buildings, which have their own rules for resolving the damage from an attack against a building hex (see pp. 166, *TW*, and p. 114).

**Cluster Weapons:** For weapons that use the Cluster Hits Table, use the weapon's total Damage Value.

**LOS:** When trying to damage a planetary condition in a given hex, treat the condition as a standing 'Mech. If the "'Mech" would have partial cover from the attack (see p. 102, *TW*), then the attacker cannot attempt to damage the planetary condition. This rule does not apply to buildings, which have their own rules for resolving LOS (see pp. 166, *TW*, and p. 114).

### Terrain Displacement

In most instances, when a base terrain type's or terrain modification's TF is reduced to 0, nothing further occurs beyond the change in a hex as described on the Terrain Factor and Conversion Table (see p. 64). However, some instances exist when the reduction of a hex's TF to 0 results in the terrain itself displacing.

**Clear/Rough:** There are two instances in which a clear/rough hex's terrain may displace.

- If a clear/rough hex's TF is reduced to 0
- If the total tonnage of units in the hex (DropShips do not count) is more than the clear/rough hex's TF x 2

In both instances, if an adjacent hex is one level lower (or more), the terrain will displace into that hex in the way described below; if there is more than one adjacent hex with a lower level, randomly determine which hexside the terrain displaces into (the terrain will only displace across a single hexside).

The terrain will not collapse until the very end of the End Phase of the turn in which the TF was reduced to 0 (or the tonnage of units in the hex is greater than the current TF of the hex), after all other damage resolution has occurred.

Divide the clear/rough hex's TF at the beginning of the turn by 5 (round up; if this number is 0 or less, no damage is applied) and apply it to all units—and Terrain Factors—in the hex in which the terrain displaces. Apply the damage in 5-point Damage Value groupings, to randomly determined locations using the Front/Back column of the appropriate hit location table; damage to conventional infantry is applied as though the damage originated from another infantry unit.

**'Mechs and ProtoMechs:** 'Mechs and ProtoMechs must make an immediate Piloting Skill Roll (ProtoMechs use their Gunnery Skill Rating) with a +3 modifier. If the roll fails, the 'Mech falls into the hex where the terrain is being displaced, taking standard fall-

ing damage. Next, the damage from the displaced terrain above is applied using the 'Mech Front Hit Location Table. If the roll succeeds, the damage from the displacement is only applied to the 'Mech's feet, but it does not fall and stays in the target hex.

**Non-Airborne Units and Infantry:** Non-airborne units and infantry (with the exception of DropShips) automatically fall into the hex where the displacement is occurring, taking damage as noted under *'Mechs and ProtoMechs*.

- **Continued Displacement:** If the target hex where the terrain displaces has an adjacent hex one level lower (or more), the destroyed terrain will automatically displace into that hex as well. Divide the clear/rough hex's TF at the start of the current turn by 10 (round up; if this number is 0 or less, no damage is applied) and apply it to all units—and Terrain Factors—in the additional hex into which the terrain displaces, in the same manner as noted above.

The terrain will continue to displace into new hexes as long as any lower-level hex exists adjacent to the latest hex where the terrain displaced, with the damage applied to each unit—and Terrain Factors—in a new hex continuing in that format; a third hex would divide the TF by 15, the fourth hex by 20 and so on. If at any time the displacing terrain would no longer cause damage to units in a new hex, even if a lower-level hex exists, the terrain stops and does not enter the new hex.

- **Units and Continued Displacement:** If the terrain displacement continues beyond the hex in which a unit is located, all units will automatically displace into the new hex. There are two exceptions involving 'Mechs and DropShips. If 'Mechs make their initial Piloting Skill Roll to stay standing, they are not displaced; DropShips are never displaced.
- **Order of Damage/Events:** The falling and displacement of units—and the damage involved—are resolved first in every hex; if this results in further displacement of units, that is resolved first. Then the damage from the displacing terrain is applied. Finally, once all such events have been determined, the players determine if another terrain displacement will occur, as noted above.
- **New Hex Conditions:** Any hex where terrain has displaced is now considered a gravel pile hex (see p. 30), along with any other planetary conditions that may already exist in the hex.



DK

*A minor cave-in due to damage almost stops a Solaris VII duel.*



While the above rules are mainly geared toward a “rock slide,” they can be used to simulate several different types of terrain slides. For example if using deep snow across the entire playing area, the same rules could be used to simulate an avalanche.

*In the Terrain Damage and Displacement Diagram, a scenario is unfolding on the Deep Canyon #1 map. The Light Snow planetary condition exists in all hexes. As the battle is relatively small, the players have decided to track movement and combat damage across all planetary conditions, which includes the underlying terrain of all hexes (this choice feels particularly appropriate, as moving giant machines of war along the edges of a canyon’s precariously balanced rocks and crevasses can be dangerous).*

*During the Movement Phase of a turn, a Hauberk battle armor unit enters Hex A. As shown on the Terrain Factor and Conversion Table, the unit cannot damage light woods and so no damage is applied for the movement. However, it can damage the light snow in the hex, and so 1 point of damage is applied to the light snow [8 tons (2 tons per trooper as shown on the Advanced Battle Armor Weights Table; see p. 187) / 10 = .8, rounding up to 1].*

*When the Goblin Infantry Tank enters Hex A, it automatically damages the woods and light snow. The 45-ton tracked vehicle inflicts 5 points of damage [45 (weight of tank) / 10 = 4.5, rounding up to 5] to the light woods as well as the light snow.*

*An 85-ton BattleMaster enters Hex B, automatically inflicting 9 points of damage [85 (weight of Mech) / 10 = 8.5, rounding up to 9] against both the snow and Hex B. Afterwards, a DI Morgan vehicle also enters Hex B, automatically inflicting 10 points of damage [100 (weight of vehicle) / 10 = 10] against the light snow and the hex; as the light snow’s TF is only 15, it is immediately reduced to mud.*

*Unfortunately, during the Indirect Artillery Attack Phase of the same turn, a Cruise Missile/90 lands precisely in Hex B. As a result, 90 points of damage are applied to the BattleMaster and DI Morgan (both units survive), as well as to Hex B.*

*Then 65 points of damage are applied to all the immediately adjacent hexes. The players mark down the damage to all the Clear terrain hexes (all the light snow is turned to mud). Then they look at Hex A: the damage reduces the light snow there to mud and the light woods to Rough terrain (especially as the area-effect weapon damage is doubled against such planetary conditions). Then 65 points of damage is applied to the units in Hex A as well. The Goblin barely survives; because the cruise missile is an area-effect weapon and damage is applied to each trooper, the Hauberk battle armor is eliminated.*

*Then 40 points of damage are applied to the next adjacent hexes. Again, the players mark down damage to all clear hexes (all the light snow is turned to mud); again, the light trees in Hex E are reduced as the area-effect weapon doubles its damage against the woods.*

*Finally, the players track the last 15 points of damage applied to each clear hex in the next adjacent hexes; the light snow is reduced to mud in all those hexes.*

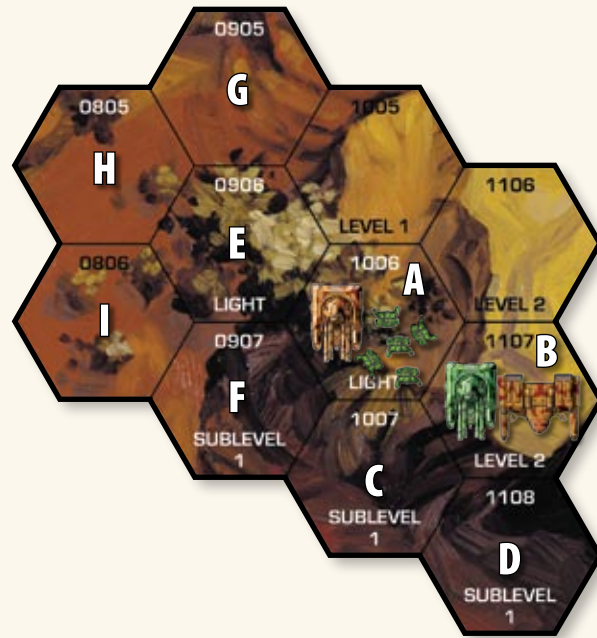

• TERRAIN DAMAGE AND PLACEMENT DIAGRAM •

*The players now have something else to contend with at the end of the End Phase of the current turn. The current TF of Hex B is 91 [200 (TF at start of turn) – 9 (damage inflicted by BattleMaster movement) – 10 (damage inflicted by DI Morgan movement) – 90 (damage inflicted by Cruise Missile/90) = 91]. If the combined weight of any units [85 (Mech tonnage) + 100 (DI Morgan tonnage) = 185] in Clear/Rough terrain is more than double the current TF [91 (current TF) x 2 = 182], the hex collapses. The TF of the hex is automatically reduced to 0. Because there are adjacent hexes at a lower level, a displacement also automatically occurs.*

*First, the players determine where the displacement will occur: into hexes A, C or D. The players roll and determine the displacement will fall into Hex A (it only falls into a single hex, even if multiple hexes are available). The controlling player of the BattleMaster must immediately make a Piloting Skill Roll to avoid falling and being swept away in the displacement. A roll of 10 means a success and the Mech stays on its feet despite the +3 modifier. However, damage done by the displacing terrain must be assigned and so 40 points of damage are applied to the Mech’s legs [200 (TF of the hex at the start of the turn) / 5 = 40]. The BattleMaster remains standing, now in a Level 1 rough hex, with a current TF of 200.*

*Unfortunately for the DI Morgan, it is automatically displaced into Hex A. It will take 20 points of damage for a two-level fall [100 (DI Morgan tonnage) / 10 x 2 (levels fallen) = 20]—which will also be inflicted against the target hex—and then 40 points of damage for the displaced terrain. The displaced terrain will also inflict 40 points of damage against the Goblin Infantry Tank (which the players determine destroys it) and against Hex A itself, leaving its current TF at 70 [200 (TF at start of turn) – 5 (Goblin movement) – 20 (DI Morgan falling damage) – 65 (Cruise Missile/90) – 40 (displacing terrain damage) = 70].*

INTRODUCTION

ADVANCED GROUND MOVEMENT

ADVANCED COMBAT

ADVANCED BUILDINGS

ADVANCED SUPPORT VEHICLES

GENERAL RULES

ADVANCED SUPPORT VEHICLE CONSTRUCTION

ADVANCED WEAPONS AND EQUIPMENT

INDEX

RECORD SHEETS



An adjacent hex is at a lower level, and so displacement continues. Displacement could move into Hexes E, F or C. The players randomly determine the location and come up with Hex E. Once again, the DI Morgan is automatically displaced and so will once again take 20 points of damage for the fall; this damage would have been inflicted against both the woods and the target hex, but since the woods are gone, only the hex receives the damage. Damage from displacement is then determined to be 20 points [200 (TF of the hex at the start of the turn) / 10 = 20], which is applied both to the DI Morgan and Hex E.

Once again there is an adjacent hex at a lower level, and so displacement continues. Displacement could move into hexes F, I, H and G. The players again randomly determine the location and come up with Hex I. The players are almost getting used to resolving the situation and quickly determine that the DI Morgan is again automatically swept down, taking another 20 points of damage for the fall (which is inflicted against Hex I as well) and then 14 points of damage from the displacement [200 (TF of the hex at the start of the turn) / 15 = 13.3, rounding up to 14], which is also applied to the hex.

One further displacement can still occur. Hex F is adjacent to Hex E and a level lower, and so displacement occurs once more. Provided the DI Morgan has survived this long, it will once more displace into Hex F, taking another 20 points of damage from the fall (again, is also inflicted against Hex F) and then 10 points of damage from the displacement [200 (TF of the hex at the start of the turn) / 20 = 10], which is also applied to the hex. Even though there is enough terrain left to displace, no adjacent hex now exists that is also a level lower, and so no further displacement occurs.

Finally, the players note that the hexes where a displacement occurs (A, E, I and F) are now considered gravel piles.

If any of the falling and displacement had reduced a hex's TF to 0, then after the complete resolution of Hex B's displacement had occurred, those further displacements would also be resolved, in the appropriate order.

## PLANETARY CONDITIONS TABLES

As noted under *Expanded Movement Costs and Planetary Conditions Rules* (see p. 28), players can simply assign planetary conditions to a given scenario. However, weather is always uncertain, and all too often intel on a battlefield is lacking, leaving combatants to make decisions on the fly for how to overcome bad weather and surprising terrain to still achieve victory. The Planetary Conditions Tables help to simulate this X factor of combat, by randomly injecting planetary conditions not necessarily of any player's choosing.

For ease of use, the tables are split into six tables covering weather conditions and six tables covering base terrain types, terrain modifications and terrain conditions. Each set of six tables has a corresponding seventh "general" table to randomly roll any of the six correlated tables. A final sub-table exists for atmospheric pressures.

Players may either select a specific Weather Table, and then roll 1D6 to determine the exact weather rules to be used in a game, or for a truly random situation, roll 1D6 on the General Weather Table to determine the specific Weather Table for the scenario and then roll 1D6 to determine the exact weather rules to be used in a game.

Likewise, players may either select a specific Terrain Table and then roll 1D6 to determine the exact terrain rules to be used in a game, or to really mix things up, roll 1D6 on the General Terrain Table to determine the specific Terrain Table for the scenario and then roll 1D6 to determine the exact terrain rules to be used in game.

**Conflicting Planetary Conditions:** When randomly determining planetary conditions, remember to resolve any conflicting conditions before play begins (see p. 29).

## Planetary Conditions and Mapsheets

While any of the terrain and weather conditions in this section can be used with any mapsheet, the Planetary Conditions to Mapsheets Table provides a quick and easy way to match up the most appropriate mapsheet types with the general terrain and weather condition types in use in a given scenario.

## PLANETARY CONDITIONS TO MAPSHEETS TABLE

Planetary Condition	Mapsheet Terrain
Weather Table 1: Solar	Badlands, Wooded, Mountains
Weather Table 2: Wind	Flatlands, Coastal, Mountains
Weather Table 3: Rain	Wetlands, Hills, Mountains
Weather Table 4: Snow	Mountains
Weather Table 5: Extreme Temperature	Badlands, Flatlands, Coastal, Mountains
Weather Table 6: Combined Weather	Flatlands, Coastal, Hills, Mountains
Terrain Table 1: Flora/Fauna	Hills, Wetlands, Wooded
Terrain Table 2: Extreme Temperature	Badlands, Flatlands, Coastal, Mountains
Terrain Table 3: Water	Wetlands, Coastal
Terrain Table 4: Hostile	Wetlands, Badlands, Mountains
Terrain Table 5: High/Low Gravity	Any
Terrain Table 6: Ground	Hills, Badlands, Wooded, Mountains



INTRODUCTION

ADVANCED  
GROUND MOVEMENT

ADVANCED  
COMBAT

ADVANCED  
BUILDINGS

ADVANCED  
SUPPORT  
VEHICLES

GENERAL  
RULES

ADVANCED  
SUPPORT VEHICLE  
CONSTRUCTION

ADVANCED  
WEAPONS  
AND EQUIPMENT

INDEX

RECORD SHEETS

## PLANETARY CONDITIONS TABLES

### 1D6 General Weather Table

1	Light
2	Wind
3	Rain
4	Snow
5	Extreme Temperatures
6	Combined Weather

### 1D6 Weather Table 5: Extreme Temperatures\*

1	-70C to -60C (p. 62)
2	-59C to -40C (p. 62)
3	-39C to -30C (p. 62)
4	50C to 60C (p. 62)
5	61C to 70C (p. 62)
6	71C to 80C (p. 62)

### 1D6 Terrain Table 3: Water

1	Rapids (p. 50)
2	Torrent (p. 52)
3	Hazardous Liquid Pools (p. 49)
4	Mud (p. 50)
5	Swamp (p. 51)
6	Extreme depths (p. 42)

### 1D6 Weather Table 1: Light

1	Pitch Black (p. 58)
2	Moonless Night (p. 58)
3	Full Moon Night (p. 58)
4	Dawn/Dusk (p. 58)
5	Glare (p. 58)
6	Solar Flare (p. 58)

### 1D6 Weather Table 6: Combined Weather

1	Gusting Rain (p. 59)
2	Snow Flurries (p. 60)
3	Blizzard (p. 60)
4	Blowing Sand (p. 62)
5	Ice Storm (p. 62)
6	Lightning Storm (p. 59)

### 1D6 Terrain Table 4: Hostile

1	Meteor Shower (p. 56)
2	Earthquakes (p. 55)
3	Atmospheric Pressure (p. 54)**
4	Tainted /Toxic Atmospheres (p. 56)
5	Magma (p. 36)
6	Electromagnetic Interference (p. 55)

### 1D6 Weather Table 2: Wind

1	Light Gale (p. 61)
2	Moderate Gale (p. 61)
3	Strong Gale (p. 61)
4	Storm (p. 61)
5	Tornado F1-F3 (p. 61)
6	Tornado F4+ (p. 62)

### 1D6 General Terrain Table

1	Flora/Fauna
2	Extreme Temperature
3	Water
4	Hostile
5	High/Low Gravity
6	Ground

### 1D6 Terrain Table 5: High/Low Gravity\*

1	.1 to .3 (p. 55)
2	.4 to .6 (p. 55)
3	.5 to .9 (p. 55)
4	1.1 to 1.3 (p. 55)
5	1.4 to 1.5 (p. 55)
6	1.6 to 1.9 (p. 55)

### 1D6 Weather Table 3: Rain

1	Light Fog (p. 57)
2	Heavy Fog (p. 57)
3	Light Rainfall (p. 59)
4	Moderate Rainfall (p. 59)
5	Heavy Rainfall (p. 59)
6	Torrential Downpour (p. 59)

### 1D6 Terrain Table 1: Flora/Fauna

1	Planted Fields (p. 38)
2	Woods (p. 40)
3	Jungle (p. 31)
4	Clear
5	Level 1 Foliage (p. 36)
6	Bug Storm (p. 40)

### 1D6 Terrain Table 6: Ground

1	Sand (p. 39)
2	Dirt/Gravel/Paved Roads (p. 51)***
3	Gravel Pits (p. 30)
4	Heavy Industrial Zone (p. 31)
5	Sheer Cliffs (p. 39)
6	Half Levels (p. 31)

### 1D6 Weather Table 4: Snow

1	Sleet (p. 60)
2	Light Hail (p. 57)
3	Heavy Hail (p. 58)
4	Light Snowfall (p. 60)
5	Moderate Snowfall (p. 60)
6	Heavy Snowfall (p. 60)

### 1D6 Terrain Table 2: Extreme Temperature

1	Black Ice (p. 40)
2	Ice (p. 50)
3	Thin Snow (p. 52)
4	Deep Snow (p. 41)
5	Tundra (p. 62)
6	Geyser (p. 48)

### 1D6 Atmospheric Pressure Table

1	Vacuum (p. 54)
2	Trace (p. 54)
3	Thin (p. 54)
4	Standard (p. 54)
5	High (p. 54)
6	Very High (p. 55)

\*Extreme Temperature weather and High/Low Gravity terrain can go above and beyond the conditions listed on the table. If the players roll a 1 or a 6 on either table, provided all players agree, the playing group can simply choose a temperature/gravity higher or lower than that represented by the table.

\*\*Immediately roll on the Atmospheric Pressure Table at bottom right of this page.

\*\*\*Players may choose which type of road, or randomly determine which type.





# GLANCING BLOWS

Jason M. Hardy

**ORESTES**  
**FREE RASALHAGUE REPUBLIC**  
**16 FEBRUARY 3052**

It had been solo combat. That was the problem—there had been only two pilots, two machines involved. If it had been otherwise, if it had been different, maybe there would have been more witnesses, maybe even cockpit footage recorded by others who stood nearby and couldn't help but take a moment in the chaos to stand and watch. But it had been solo. Everyone else stayed away.

Haakon Magnusson already knew this task of reconstruction would consume him. Maybe he'd come out on the other side of it some day, in a year or five or ten, maybe he'd have a clear enough picture of what happened that he could say to himself, enough, no more, now I know. I know what happened. Or maybe he would exhaust himself and be forced to quit because he wouldn't have the energy to continue, or maybe his drive to discover what happened would diminish and he would no longer feel the need to interrogate anyone who had been anywhere near Satalice that day. He couldn't imagine that happening, but the universe had proved exceptionally able to produce events completely beyond his conception.

He closed his eyes, weary, then opened them again. He didn't want to sleep. He didn't want the company of his dreams right now. They kept producing his son for him in various guises. His infant son, his son as a youth, and, most cruelly, his son as triumphant warrior, returning home from the fight with sweat on his brow and a grim smile on his mouth. He would willingly go without sleep forever if it meant he could avoid being haunted by that image.

Keeping his eyes open, though, was no better. What did he have to look at? An empty room, white and austere like an untouched glacier. He hated the white furnishings and their smooth, con-

toured surfaces. He hated the screens fitted into the walls at various intervals, and he especially hated the information they kept shoving in his face. On top of all that, he hated that the entire installation had been his idea.



"This will be the easiest of all," Haakon had said, on a planet far away, the first time he had set up a room like this. He pointed to the space between joists where a wall would eventually be erected. "Big, but not too big. It has to be visible from anywhere in the room, but I don't want it to overwhelm any of the other displays."

"What's it going to be hooked up to?" asked Vanessa, dutifully making annotations in her notepaper as it recorded Haakon's words and translated them into text.

"Same mainframe as the others, but it doesn't need to be as complicated. This is going to display a simple image."

"And that image will be ..."

"The Free Rasalhague Republic, of course, in all its glory, from Orestes to Damian." It would be perfect, a reminder of his greatest joy every time he walked into the room. It would be a comfort in his most difficult times. He could look at the map, smile, and know that Free Rasalhague existed. That would take the edge off any sorrow.



When Haakon had fled Rasalhague, he'd made sure his map had come with him. He was determined to have his Republic with him, no matter what else they took from him.

But the map was no longer a comfort. Every glance he gave it brought sorrow. The Republic it showed was a mere shadow of its

former self, planets darkened to indicate their fall to the Clans. More than fifty worlds gone! Rasalhague, the heart of his nation, where he had first designed his command room, where he had carefully placed the map that gave him so much pride, now seemed impossibly distant from his current border.

His nation had existed, whole and intact, for sixteen years. The survival, even triumph, of the Republic in the Ronin War convinced Haakon that he had been more than a deft politician—he had been a tool of destiny. Free Rasalhague was meant to be, and he was meant to create and lead it.

But then the invaders had come. Swarming from the rimward border of his nation, the Clans had captured fifty of the Republic's worlds in less than a year. Fifty circles now black.

He should take the map down. How could he look at planets like New Oslo, Skandia and Rasalhague, especially Rasalhague, darkened? And more still falling. Satalice was now dark. Satalice, where his son had been. Where Haakon had sent the bulk of the KungsArmé, the hopes of a reeling Republic.

Where those hopes had come to nothing.



His son Ragnar had piloted an *Ostsol*, 25 tons heavier than the *Wolfhound* used by the merc-turned-Wolf barbarian, Phelan. Haakon had heard from dozens of soldiers already, by word or by letter, and each and every one of their accounts was contradictory.

The one thing they all agreed on was that Ragnar's last fight came at the end of the Battle of Satalice, after several hours of brutal fighting.

"The Clanner drew him out," one infantry *løjtnant* had reported. "He must have been planning it for awhile, but it took him a long time to work his way to where he needed to be. But if you were paying attention—and I had to, we always had to know where that damn *Wolfhound* was—you could see the Clanner was herding Ragnar, guiding him, practically steering the Prince away from the center of the battle so he could engage him one-on-one. He'd lay down a fusillade of energy in front of the Prince to push him backward, or graze a beam against one side or another to get him to move laterally. The precision—I've never seen such accuracy. He could have made them all direct hits, I'm sure of it, but that's not what the Clanner wanted. He wanted to take him on by himself, so he used these shots, these darts he was throwing, to draw the Prince out. Then, on open ground, it was just the two of them, and the Clanner launched himself at the Prince like a wolf at a rabbit. He got what he wanted."

That was one story. Here was another.

"The Prince was in control the whole time," said the driver of a transport. "You should've seen how he moved on the field, you would have been so proud. The damn Clanner



couldn't get a clear bead on him, he was firing wild, taking shots that didn't come anywhere near the Prince. I could tell Ragnar wanted a piece of this guy—I don't know how, but you can tell, you know? You can feel it—but there kept being people in front of him he needed to take care of, people closer than this damn Phelan character. It didn't help that the Clanner was faster, and he used his speed. Fire and run, fire and dodge, fire and run. But the Prince wouldn't slow down. The Prince kept after him. He was smart, right? Knew what victory over that *Wolfhound* would mean. Could take the whole day for us. So he kept after him, playing that field like a chessboard. Every shot set up something that was two or three moves away. The *Wolfhound* tried to stay away, but he just ... he wasn't a pure tactician, like the Prince was."

And it just got worse. None of the accounts seemed to agree on anything—except that the Clanner had won and Ragnar was gone.



There should have been a great funeral. Wooden boat set on fire, sparks flying into the night sky, people mourning theatrically and possibly throwing themselves onto the burning ship before it drifted into the deep water. Maybe Haakon would have been one of them.

Except Ragnar wasn't actually dead. There was no body to send to sea. Besides, the way things were going, Haakon had trouble believing he would be able to assemble enough true Rasalhagian warriors for a proper funeral.

But he could imagine. If he closed the eyes, he could feel the flames lapping his arms, his legs, blistering his skin, eating him away into ash.

Those people of ancient Terra knew what they were doing. A warrior's exit from this life should be a bright blaze of glory, not slow decomposition in the ground. A warrior should be here one moment, and then gone like that. Because a warrior who stays around too long absorbs blow after blow after blow, and even if they're light blows, even if they barely slow you down, they eventually take their toll, and you ... you eventually aren't a warrior anymore.

Just like a nation of planets. The Inner Sphere was seemingly based on the idea that nations could lose a planet or two on the border and be okay. Some planets got traded back and forth the way football teams traded aging quarterbacks. That sort of loss could be endured.

But loss after loss after loss—that was long, drawn-out pain. It would be better if the whole realm, the whole Republic, were wiped away with a single blow. An explosion, or a sucking black hole, and Free Rasalhague would be gone. A suitable, dignified death.

He looked out at the night sky and focused on the space between the stars.



There was business the next day. The volume of it seemed small, of course, but still, there were a handful of planets and billions of people, and a ruler had tasks to perform. And there was the slow, backward trickle of the war.

"Supply routes are being changed," said Haakon's chief of staff. "You probably don't need to know the details, but in case you're curious a file outlining the new routes has been sent to your noteputer."

"Are the supplies ever catching up to the troops?"

The chief glanced at a handheld screen. "Sometimes," he said. "But I wouldn't worry too much about it. Of all the reasons we've had for losing, low supplies are far down the list."

Haakon only nodded in reply.

"The flow of refugees seems to have slowed a bit," the chief said. "For once we have enough supplies on most planets to meet the demand. It's probably only a temporary lull, though. I'm sure the pace will increase again, and we will need to be ready for another surge."

"No," Haakon said.

"Pardon, sire?"

"No. There will be no surge."

"With all due respect, sire, the pace of attacks is not slackening, and ... and, well, we have not gained additional victories. There will be more refugees."

"There will be more defeated Rasalhagians," Haakon said. "But there will be fewer refugees. They will no longer flee."

"How do you ..."

"They have nowhere to flee to," Haakon said. The words came out flat, emotionless. "Refugees flee because they are looking for someplace safer. But there are fewer and fewer such places in the Republic. Soon there will be none." He looked at his ever-shrinking map on the wall. "They have realized they will not be able to escape Clan rule."

The briefing ended soon after that. The chief knew better than to dispute Haakon's assertion. The black mood had been on him for some time, and there was nothing the chief could do to talk it away.



The chief had tried to buoy Haakon's spirits once, not long after Ragnar had been lost.

"He's not dead," the chief said. "That's one thing all the reports agree on. Your son is captured, but not dead."

Had Haakon seen the humor in anything anymore, he would have laughed. Was that supposed to be better? Was he supposed to be happy that his son was in the hands of the people who were ripping his realm apart? Did anyone know what they did to their prisoners? Or perhaps we was really dead...

Haakon kept having a vision. A vision of the last Rasalhague forces making a final stand on some coreward planet—likely here on Orestes. The battered, shattered remnants of the KungsArmé fall under the relentless Clan attack, until there is nothing between Haakon and the enemy but a small unit of loyal troops. They fight valiantly in their final battle, but there is nothing they can do to slow the onslaught. Then, at the end, there is nothing besides Haakon, his dead soldiers, and the advancing Clanners. And then one of the Clan `Mechs stops, the hatch opens, and a face appears. Ragnar's face, but not his. The features are the same, but the expression is twisted, malevolent. Alien. He sneers for a brief moment, then disappears back inside his `Mech.

Then he blasts his father into nothing.

That could be what they are doing to my son, Haakon thought. They will steal him from me completely before they are done. What comfort can I draw from that?

The chief talked on for a while and watched Haakon's eyes sink deeper into his head. After that effort, the chief didn't attempt to cheer him again.



Here, in the present, days come and go, and Haakon is amazed each morning to wake up and find out he is still alive. That he emerges from his bedroom and functions, at least to a degree. He had put so much planning into Ragnar's ascension to the throne, so much care into his upbringing, that when that stopped—shouldn't everything else have stopped? But people went on, events went on, much as they had before his son was lost.

He knew he was not the only one who mourned his son. The outpouring of grief was nationwide, and the people had been sent reeling. But even in the midst of all this, even as the Republic fell apart, people still lived. They worked, they occasionally played, they found time to be with those they wanted to be with. They persisted. The entire Republic might fall, and the people would carry on. Many of them had been alive before the Republic existed, living in a Rasalhague of the mind rather than a political reality. They had survived without it before. They could endure without it again.

One day, while he was looking out a window and watching life proceed around him, a thought struck Haakon. He called to one of his assistants, then pointed at the map.

"Turn them on," he said. "Turn all of them on."

The assistant complied without hesitation. Soon, it was there again, restored with a few keystrokes. The Free Rasalhague Republic, mighty and strong.

The planets were still there. They had fallen, but they had not vanished. They remained as real as their history, and that history was written in Rasalhague ink. They had waited a long time for independence. If necessary, they could wait again.

Haakon could not. The struggle of twenty years ago could not be repeated, not by him. But perhaps there was someone out there, someone who survived the onslaught, who would lead the Republic back. Perhaps.

It was the first time since his son had fallen that Haakon saw anything in the future except blackness.



His chief of staff came again, and again and again, every day with new business, new minutiae. The details of retreat were considerable, and retreat remained all the KungsArmé could do in the face of its implacable enemy.

Occasionally the chief brought him yet another account of the battle between

Phelan Kell and his son. Haakon still read them all, but with an air of detachment, as if he were reading dry history, not family tragedy. One account in particular struck him, the story related by a crewman from a scout vehicle. The man had eagle eyes and a sharp memory, and his account bore the ring of truth—even though it directly contradicted several other accounts. If it was not the complete truth of what happened, it was a truth Haakon could accept.

"The critical element to understanding the fight between Phelan and the Prince," the crewman wrote, "is knowing that the Clanner had the smaller, faster Mech. Meaning he also had less firepower.

"Anyone who rises to a high rank and still prefers a light Mech obviously knows the key to fighting in one—never stop moving. Never fool yourself into thinking there's a moment where you can stop and stand and pummel your opponent. It was a concept the Clanner understood very well.

"I didn't see the Clanner land too many clean shots on the Prince, and I never saw him fire while standing still. He was darting, turning, serpentineing, circling—anything. That made his shots wild, but he knew how to compensate. They didn't hit dead center very much, but they seldom missed. A beam would cut into the Prince's leg, into an arm, into his torso, whittling away the edges. Not enough to knock the Prince out, but enough to keep him off balance. Glancing blow after glancing blow after glancing blow.

"I couldn't tell you which was the shot that finally decided the combat. There was no single killshot. It was the final accumulation of all those minor blows, all combined, that finally finished the Prince off.

"I am only guessing at this last part, but perhaps the Clanner's strategy was intentional. His marksmanship was uncanny, making hits when other warriors wouldn't have bothered to fire. I eventually got the impression that the nature of the blows was intentional—that the Clanner wanted to win, but wanted the Prince to survive. And so he fought the way he did."

Haakon had no way of knowing if that was true. Who could know what was in a Clanner's head? But if he couldn't know, he could at least believe.

He slept that night. Not soundly, but he slept. As he lay on his pillow, he heard his heartbeat echo in his ears. He imagined it was the heartbeat of Rasalhague, and of his son. Somehow, it was still beating. Cataclysms and captivity would come, but that heart would still beat.

Rasalhague would never truly fall.

After-action Reports - Ragnar

**EYES  
ONLY**



FL

Paula "Lady Death" Trealine directly enters the fray during a raid against a Periphery world.

Combat is at the heart of *BattleTech*. When 'Mechs and other units pound each other with barrages of laser and autocannon fire, the fun really begins. This section greatly expands the options available to players for *BattleTech* combat.

As with all optional rules, all players must agree to use a particular rule in a given game. As these rules in particular will have a direct effect on how a game unfolds, we recommend that players review all the rules in this section before choosing the optional rules they want to include in their game.

## GENERAL RULES

The following rules apply to weapon attacks and physical combat, as appropriate.

### EXPANDED CRITICAL HITS AND DAMAGE

In standard-rules *BattleTech*, the ability of weapons to deal critical hits and how those critical hits affect a 'Mech are kept simple, for game balance and also for ease of play. The expanded rules in this section create differences between the critical damage-dealing abilities of the proverbial "golden BB" from an LB-X autocannon and the horrific destruction wreaked by an AC/20. What's more, instead of a single critical hit immediately eliminating equipment, a range of effects is introduced to better reflect degradation of ability due to damage. This rule applies only to 'Mechs, though it does not apply to a 'Mech's engine, gyros, sensors or double heat sinks.

Remember that players pick and choose which optional rules they wish to use, and these are not intrinsically linked; players can use both, or just one or the other of these rules in their games.

### Advanced Determining Critical Hits

In place of the standard rules for determining critical hits (see *Critical Damage*, p. 123, *TW*), use the following rules.

Every time the internal structure of a 'Mech takes damage from a weapon attack, roll 2D6 and add a modifier based on the

## ADVANCED DETERMINING CRITICAL HITS TABLES

Damage Value Grouping	Modifier
1–5	+0
6–10	+1
11–15	+2
16–20	+3
21+	+4

Dice Roll (2D6)	Effect
2–8	No Critical Hit
9–10	Roll 1 Critical Hit Location
11–12	Roll 2 Critical Hit Locations
13–14	Roll 3 Critical Hit Locations
15+	Head/Limb Blown Off; Roll 3 Critical Hit Locations*

\*Only roll 3 critical hit locations if the attack strikes the torso



Damage Value grouping of the hit, as shown on the Advanced Determining Critical Hits Table, and then compare the die roll result to that same table. On a result of 9 or higher, the target unit takes critical damage.

The Damage Value grouping modifier does not take into account the weapon's overall Damage Value (or Attack Value), but only the Damage Value grouping as it applies to the 'Mech. Furthermore, it doesn't matter how much internal structure was damaged, just that it was in fact damaged. For example, a HAG 40 has a Damage Value of 40 points, but since all its damage is applied in groupings of 5 points (or less), at most any potential critical damage by a HAG would never apply a modifier to the die roll result. An AC/20, however, has a Damage Value grouping of 20, and so would apply a +3 modifier when determining a critical hit (again, regardless of how much internal structure was actually damaged by the attack).

Use all other standard rules (see *Critical Damage*, p. 123, *TW*) for determining the specific locations of critical hits rolled.

**Aerospace Units Vs. Ground Units:** Due to the abstract nature of certain weapons when mounted on aerospace fighters, the ability of a fighter to deal devastating damage to ground units is significantly increased. If players wish to keep this increased level of lethality for their fighters, they can feel free to do so. However, if that increased lethality is not desired, then when using aerospace units vs. ground units, use the standard rules for determining critical hits.

### Expanded Critical Damage

Expanded Critical Damage does not apply to the engine, gyros, sensors, double heat sinks, or any physical attack weapons.

The expanded Critical Damage rule works as follows: every time a piece of equipment suffers a critical hit, it may be only damaged or it may be destroyed. If more than half of an item's slots have been damaged, the equipment is considered destroyed. Otherwise, it may continue functioning.

When using these expanded critical damage rules, a single critical slot can be damaged multiple times until it is "destroyed."

At the end of a phase in which an item is damaged, roll 2D6 on the appropriate Critical Damage table to check the status of that item. Add the total number of damaged slots for the item, regardless of when the damage occurred, to the die roll result. Roll only once per phase for each item damaged during that phase, regardless of the number of times the item was hit. Damage takes effect at the end of the phase.

The effects of multiple critical hits are cumulative. For example, two Focus Misaligned results against a Direct-Fire Energy/Pulse weapon result in the weapon inflicting 2 less points of damage and an additional +2 to-hit modifier for subsequent attacks at medium and long range. Critical effects that call for a roll with a certain result (such as a To-Hit Roll result of 2, or a result of 7+ for the item to work) increase their target numbers by +1 for each additional hit. For example, an autocannon (Direct-Fire Ballistic weapon) that has suffered three Ammo Feed Damage results will sustain an ammunition explosion on a To-Hit Roll result of 4 or less (rather than the result of 2 that indicates an explosion after a single Ammo Feed Damaged result).

A jammed ballistic or artillery weapon may not fire. The jam can be cleared using the same rules for clearing a jammed Rotary Autocannon (see p. 140, *TW*).

**Cockpit Critical Hit:** Under these rules, a cockpit critical hit does not automatically destroy the cockpit and kill the MechWarrior. Instead, the player rolls on the Cockpit Critical Damage Table and applies the results. Unless the player rolls a 12+, if there is internal structure remaining in the location, the cockpit slot is not marked off as destroyed.

**Electronic Equipment:** For Electronic Equipment that provides a continuous effect throughout a turn, the controlling player should roll at the start of each subsequent turn to see if it functions (see Equipment Critical Damage Table, p. 76). For example, an Inner Sphere Guardian ECM Suite takes 1 critical hit in a turn and the controlling player rolls a 10 on the Equipment Critical Damage Table. At the start of each subsequent turn for the rest of the scenario, the player must roll a 10+ for the Guardian ECM Suite to function in that turn.

### Keeping Damage Secret

In a refereed tournament or one with a gamemaster, such as a Double Blind game (see p. 220), it is more fun to keep the effects described above secret from the players. For example, if a player's AC/10 has an ammo feed problem, the gamemaster should tell the player that the weapon makes a "funny sound" when fired. When the player gets a result of 2 on his to-hit roll, the explosion of his weapon comes as a complete surprise.

### FUMBLES

Standard-rules play assumes that all weaponry functions perfectly until it is damaged and that all MechWarriors, while they may miss, never do so in a catastrophic way. Real combat is much messier and despite the best maintenance and training, both machine and warrior can fumble.

## DIRECT-FIRE ENERGY/PULSE WEAPONS CRITICAL DAMAGE TABLE

2D6* Roll	Effect
2-3	Minor damage; no effect
4-5	Moderate damage; attacks with weapon add +1 to-hit modifier
6-7	Focus misaligned; weapon inflicts -1 damage, additional +1 to-hit modifier applies to shots at medium and long range (as well as at extreme and LOS range, if those rules are in use; see p. 85.
8-9	Emitter damage; weapon generates +1 Heat Point. To-Hit Roll result of 2 for an attack with the weapon causes overload with effects identical to an ammo explosion, inflicting damage equal to the damage inflicted by the weapon; for Variable Damage weapons, use the Damage Value at short range.
10-11	Weapon severely damaged (mark off another critical slot on the weapon, the top most slot available); cannot fire
12+	Weapon destroyed (mark off all critical slots on the weapon)

\*Add number of critical slots damaged to this result

INTRODUCTION

ADVANCED  
GROUND MOVEMENT

ADVANCED  
COMBAT

ADVANCED  
BUILDINGS

ADVANCED  
SUPPORT  
VEHICLES

GENERAL  
RULES

ADVANCED  
SUPPORT VEHICLE  
CONSTRUCTION

ADVANCED  
WEAPONS  
AND EQUIPMENT

INDEX

RECORD SHEETS



## DIRECT-FIRE BALLISTIC AND ARTILLERY WEAPONS CRITICAL DAMAGE TABLE

2D6* Roll	Roll Effect
2-3	Minor damage; no effect
4-5	Moderate damage; attacks with weapon add +1 to-hit modifier
6-7	Barrel damage; To-Hit Roll result of 2 for attack with weapon causes it to jam Ammo feed damage; weapons that can fire various types of ammo may no longer switch between them, must fire last ammo type used. To-Hit Roll result of 2 for attack with weapon causes an ammo explosion in an ammo bin that feeds that shot (the controlling player decides which ammo slot explodes; if there is an ammo bin with shots remaining, the player must select that slot, meaning he cannot select an ammo slot that is empty if another slot of the same ammo type is not empty).
8-9	
10-11	Weapon severely damaged (mark off another critical slot on the weapon, the topmost slot available); cannot fire
12+	Weapon destroyed (mark off all critical slots on the weapon)

\*Add number of critical slots damaged to this result

## EQUIPMENT CRITICAL DAMAGE TABLE

2D6* Roll	Effect
2-7	Minor damage; no effect
8-9	Moderate damage; player must roll 7+ before each use for damaged item to work
10-11	Severe damage; player must roll 10+ before each use for damaged item to work
12+	Item destroyed

\*Add number of critical slots damaged to this result

## COCKPIT CRITICAL DAMAGE TABLE

2D6 Roll	Effect
2-5	Minor Wound; apply one hit against MechWarrior
6-7	Moderate Wound; apply two hits against MechWarrior
8-9	Severe Wound; apply three hits against MechWarrior
10-11	Critical Wound; apply four hits against MechWarrior
12+	MechWarrior Killed/Cockpit destroyed (mark off slot)

## MISSILE WEAPONS CRITICAL DAMAGE TABLE

2D6* Roll	Effect
2-3	Minor damage; no effect
4-5	Moderate damage; attacks with weapon add +1 to-hit modifier
6-7	Damage to ranging system; shots at medium and long range suffer an additional +1 to-hit modifier (as well as at extreme and LOS range, if those rules are in use; see p. 85) Ammo feed damage; weapons that can fire various types of ammo may no longer switch between them, must fire last ammo type used. To-Hit Roll result of 2 for attacks with weapon causes an ammo explosion in the ammo bin that fed that shot (the controlling player decides which ammo slot explodes; if there is an ammo bin with shots remaining, the player must select that slot, meaning he cannot select an ammo slot that is empty if another slot of the same ammo type is not empty).
8-9	
10-11	Weapon severely damaged (mark off another critical slot on the weapon, the topmost slot available); cannot fire
12+	Weapon destroyed (mark off all critical slots on the weapon)

\*Add number of critical slots damaged to this result

## ADVANCED 'MECH HIT LOCATION TABLE

2D6 Rolls	Left Side	Front/Rear	Right Side
2*	Left Torso [critical]	Center Torso [critical]	Right Torso [critical]
3	Left Leg	Right Arm	Right Leg
4	Left Arm	Right Arm	Right Arm
5	Left Arm	Right Leg	Right Arm
6	Left Leg	Right Torso	Right Leg
7	Left Torso	Center Torso	Right Torso
8	Center Torso (R)	Left Torso	Center Torso (R)
9	Right Torso (R)	Left Leg	Left Torso (R)
10	Right Arm	Left Arm	Left Arm
11	Right Leg	Left Arm	Left Leg
12	Head	Head	Head

\*A result of 2 may inflict a critical hit. Apply damage to the armor in that section in the normal manner, but the attacking player also rolls once on the Determining Critical Hits Table, p. 124, TW.



## ADVANCED FOUR-LEGGED/PROME 'MECH HIT LOCATION TABLE

2D6 Rolls	Left Side	Front	Rear	Right Side
2*	Left Torso [critical]	Center Torso [critical]	Center Torso (R) [critical]	Right Torso [critical]
3	Left Leg	Right Leg	Right Arm	Right Leg
4	Left Rear Leg/Left Arm	Right Rear Leg/Right Arm	Right Front Leg/Right Leg	Right Rear Leg/Right Arm
5	Left Front Leg/Left Arm	Right Front Leg/Right Arm	Right Rear Leg/Right Leg	Right Front Leg/Right Arm
6	Left Front Leg/Left Leg	Right Front Leg/Right Torso	Right Rear Leg/Right Torso (R)	Right Front Leg/Right Leg
7	Left Rear Leg/Left Torso	Center Torso	Center Torso (R)	Right Rear Leg/Right Torso
8	Center Torso	Left Torso	Left Torso (R)	Center Torso
9	Right Torso	Left Arm	Left Leg	Left Torso
10	Right Arm	Left Front Leg/Left Arm	Left Rear Leg/Left Leg	Left Arm
11	Right Front Leg/Right Leg	Left Front Leg/Left Leg	Left Rear Leg/Left Arm	Left Front Leg/Left Leg
12	Right Rear Leg/Head	Left Rear Leg/Head	Left Front Leg/Head	Left Rear Leg/Head

\*A result of 2 may inflict a critical hit. Apply damage to the armor in that section in the normal manner, but the attacking player also rolls once on the Determining Critical Hits Table, p. 124, *TW*.

Whenever a player makes a to-hit roll with a result of 2, a fumble has occurred and the attack always misses; note that even if the modified To-Hit Number is 2 or less, under this rule the player always makes a die roll and on a die roll result of 2 the shot misses.

Additionally, the controlling player should immediately roll 2D6 again. On a result of 12, the weapon that missed automatically receives a single critical hit (apply the critical to the topmost unmarked critical slot of the weapon); if the Expanded Critical Damage rules (see p. 75) are in use, the player should immediately roll on the appropriate table.

### FLOATING CRITICAL RULE

Under standard rules, when the possibility of a critical hit arises by rolling a 2 on the 'Mech Hit Location Table, any critical hits are applied to the location initially rolled (center, right or left torso, depending on the attack direction). This chance for a critical hit represents the possibility of a lucky shot penetrating a chink in the 'Mech's armor and striking a vital internal component. As it is logical to assume that such lucky shots can strike areas of the 'Mech other than the torso, the following rule allows a possible critical hit to affect any area of the 'Mech. This rule applies only to 'Mech hit locations.

When a player rolls a 2 on the Hit Location Table, ignore the Torso hit location. Instead, roll the dice a second time to determine where the shot actually hits. If another 2 is rolled, that result indicates the shot struck the appropriate torso location. It does not indicate another possible critical hit. If the result is other than 2, the shot strikes the appropriate hit location. Mark off armor for that location and roll once on the Determining Critical Hits Table to see if any critical hits were inflicted on that area.

### ADVANCED HIT LOCATIONS

The following rules provide advanced (and more accurate) hit locations for 'Mechs.

#### Four-Legged and Prone 'Mech Hit Location Table

Players can use the Advanced Four-Legged/Prone 'Mech Hit Location Table to more accurately reflect hit locations against standing four-legged (quad) and prone 'Mechs. Under advanced rules, four-legged 'Mechs determine attack direction the same way as vehicles (see p. 192, *TW*).

The Left Side and Right Side columns in the Advanced Four-Legged/Prone 'Mech Hit Location Table are identical to those in the standard Hit Location Table, but are provided here for players' convenience.

#### Advanced 'Mech Hit Location Table

Players can use the Advanced 'Mech Hit Location Table to more accurately reflect side hit locations against biped 'Mechs; namely, that side hits have a chance at hitting a rear location. Players should note that the weakest part of any 'Mech armor is the rear and the use of this advanced hit location table will significantly increase the number of rear hits that may occur.

The Front/Rear column in the Advanced 'Mech Hit Location Table is identical to that in the standard Hit Location Table, but is provided here for players' convenience.

**Four-legged 'Mechs:** When using four-legged 'Mechs, players may wish to use the Front and Rear column of the Advanced Four-Legged/Prone 'Mech Hit Location Table and the side columns of the Advanced 'Mech Hit Location Table to provide the most accurate hit location situations.

### ENGINE EXPLOSIONS

Though the scientific reality of fusion engines prevents them from exploding, the dramatic effect of such an expensive piece of machinery blowing up in a huge ball of fire is so appealing to the majority of *BattleTech* players that this rule was created to satisfy the common desire for a good explosion.

INTRODUCTION

ADVANCED  
GROUND MOVEMENT

ADVANCED  
COMBAT

ADVANCED  
BUILDINGS

ADVANCED  
SUPPORT  
VEHICLES

GENERAL  
RULES

ADVANCED  
SUPPORT VEHICLE  
CONSTRUCTION

ADVANCED  
WEAPONS  
AND EQUIPMENT

INDEX

RECORD SHEETS





The fusion engines that power 'Mechs and certain vehicles are well protected from damage. Designed to operate under heavy fire, they can withstand direct hits from enemy weapons. Fail-safe devices and the basic physics of magnetic plasma confinement present in all fusion engines prevent them from exploding when damaged; instead, the engine shuts down immediately when catastrophic damage occurs (as described in detail on pages 36-37 of *TechManual*). However, secondary effects may sometimes create massive explosions.

The fusion engine of a 'Mech may explode any time four or more of its slots are destroyed in the same phase of a turn, usually when the center torso location is destroyed (also destroying the equipment contained therein).

When the fusion engine of a 'Mech takes four or more critical hits in the same phase, roll 2D6. On a result of 10 or higher, the engine explodes. In the case of fusion-powered Combat and Support Vehicles and aerospace fighters, the engine explodes on a 2D6 result of 12 after an engine critical hit.

The explosion destroys the unit and all other units in the same hex, and also starts a fire in the hex, regardless of the terrain (see p. 43). Any units in adjacent hexes take damage equal to the engine's rating divided by 10 (rounded to the nearest whole number; round .5 down). Units 2 hexes away take damage equal to the engine's rating divided by 20. Units 3 hexes away take damage equal to the engine's rating divided by 40. Divide this damage into 5-point Damage Value groupings and randomly determine each location; determine the direction of the attack from the direction of the hex where the engine exploded.

**Area-Effect Weapon:** An engine explosion is treated as an area-effect weapon, and so all rules that apply to such weapons also apply to an engine explosion.

**Buildings, Levels (Hills) and Mobile Structures:** Use the rules for Buildings, Levels (Hills) and Mobile Structures as they interact with artillery when determining the outcome of an engine explosion's interaction with such terrain features (see p. 184).

**Water:** Use the rules for Area Effect Weapons against buildings (see p. 172, *TW*) when resolving the damage from an exploding engine if the target is in a water hex. If the target is not in a water hex and an adjacent hex is a water hex, no damage is applied to completely submerged targets in that adjacent hex.

**Woods:** Woods hexes provide no protection against damage from engine explosions, even if the Woods Cover (see p. 84) rules are in use.

### Ammunition

In Standard Rules play, the destruction of a unit by an ammo explosion has no effect on any other unit in the vicinity. However, some ammo explosions can be truly titanic. For those wishing to have more spectacular results from an ammo explosion, use all the rules above for an engine explosion, with the following modification.

When a unit without CASE in the proper location to stop an ammunition explosion from destroying a unit is destroyed by an ammunition explosion, determine the total amount of damage caused by the detonation (generally equal to the amount of shots remaining times the maximum damage of each shot). Divide this amount by 10 (round down) and apply it as an area-effect attack in the destroyed unit's hex, with all units in adjacent hexes taking half this damage (round down).

### Self-Destruct Sequence

A desperate pilot may choose to destroy his own BattleMech rather than let it fall into enemy hands. Other pilots use this tactic as a last-ditch effort to take enemy 'Mechs down with them. Whatever the rationale, the wide radius of a BattleMech explosion means that it will almost certainly kill the pilot, even if he ejects.

In order to initiate a self-destruct sequence, the player must announce to his opponent that one of his units will be self-destructing, but not which one. The player secretly writes down which of his units is self-destructing during the End Phase of a turn. If the pilot wishes to eject, he will do so during the following turn's Movement Phase instead of moving the unit.

In the turn following the turn in which the announcement was made, during the Weapon Attack Phase, the self-destructing unit is revealed to all the players. The unit does not automatically explode, however. In order to correctly override the 'Mech's safety features and initiate destruction, the controlling player must make an unmodified Piloting Skill Roll. If the roll is successful, the unit explodes. If it fails, the unit does not explode, and it can no longer move, fire or make physical attacks. The controlling player may continue to make Piloting Skill Rolls in subsequent Weapon Attack Phases until successful, as long as the pilot remains in the unit. If the pilot has ejected and the player fails the initial Piloting Skill Roll to destroy the 'Mech, the unit will not explode and the enemy has just gained a nice piece of salvage.

If at any time during the self-destruct sequence the engine receives the three critical hits required to destroy the engine, the self-destruct sequence is aborted as the system controlling the sequence is destroyed. However, if an engine in this situation takes four critical hits in the same phase, then it could still explode as noted above.

### CALLED SHOTS

A called shot is similar to an aimed shot, though less narrowly targeted. An aimed shot is an attack against a specific hit location and can only be made against an immobile target. An attack "aimed" more generally, representing the pilot's skill at directing his attack against a desired general area, is a called shot. Called shots can be made against active, mobile targets.

Any attack can be a called shot. The player must announce the type of called shot—high, low, right or left—when the attack is declared. All called shots must be made with an additional +3 to-hit modifier. If the attack hits, the hit may be resolved on a different table than the one that would normally be used. For a successful called shot aimed high, consult the Shot from Above section of the Special Hit Location Table (see p. 175, *TW*). For one aimed low, consult the Shot from Below section. Units cannot aim low against a target in partial cover, or against a vehicle; vehicles are also not subject to "aim high" attacks.

For called shots aimed right and left, a successful attack strikes the target as though the attack had come from one hexside to the right or left of the hexside through which the attack would normally come, based on the line of sight. Aiming left hits the next hexside clockwise, while aiming right hits the next hexside counterclockwise. For example, if an attack would normally come in from the right side, aiming right would hit the front (one additional hexside to the right), while aiming left would hit the back (one additional hexside to the left). This means aiming left or right makes no difference if the attack is coming in straight at the front side of a 'Mech, because all three front hexsides are considered "front."





Unlike an aimed shot (see p. 110, *TW*), there are no restrictions on weapons (or targeting computers) making a called shot; the more generalized nature of “calling an area” as opposed to trying to hit a specific location means that even “scatter-style” weapons can be used in a called shot.

**Advanced 'Mech Hit Location Table:** Players may wish to disallow the use of the Advanced 'Mech Hit Location Table with “called right” or “called left” shots, as this can significantly increase the likelihood of rear torso hits.

## WEAPON ATTACKS

Unless specifically stated otherwise, the following optional rules apply only to weapon attacks.

**Super-Heavy Combat Vehicles:** Super-Heavy Combat Vehicles (including VTOLs) are considered Large Support Vehicles for the Unit Heights Table (see p. 99, *TW*).

### LINE OF SIGHT AND DEAD ZONES

The standard line-of-sight rules work well under all circumstances except one: when two opposing units are not separated by terrain equal to or higher than both of them or adjacent terrain equal to or higher than one of them, and yet logically there should be no line of sight (LOS) between them. The example below illustrates such a situation.

*In the LOS Dead Zone 1 diagram, the BattleMech in Hex A on the Deep Canyon #2 map is at Level 3. It wants to fire at the 'Mech in Hex B, which is at Level 0. As the cut-away diagram shows, no line of sight should exist between these two units, because of the Level 3 hill in Hex X. However, the standard LOS rules require the 'Mech in Hex B to be adjacent to Hex X in order to be in the hill's “dead zone.” As it stands, the 'Mech in Hex A has LOS to the one in Hex B and so can fire on it.*

The Dead Zone rule adds more complexity to calculating LOS between units, but treats dead zones more realistically. This rule is especially important in mountainous terrain, sink-holes and canyons where there is often a large difference between different units' levels.

The Dead Zone rule replaces the following standard LOS rule (see p. 100, *TW*), which reads: “Terrain along the LOS between two units is intervening if: The terrain or feature is adjacent to the attacker and equal to or higher than the attacker's level; or the terrain or feature is adjacent to the target and equal to or higher than the target's level.” All other standard LOS rules still apply. Because the standard line-of-sight rules work well in most situations, advanced line of sight should only be used when a player thinks there is a legitimate line-of-sight question. Players should not invoke this rule unless absolutely necessary, as it will slow down game play.

### Dead Zone Rule

Players must check for dead zones if there is no intervening terrain equal to or higher than both the attacker and the target, but there is still some question as to whether LOS exists. Note which of the two units is at the higher level and which is lower. Then find the highest-level hex between the two units.

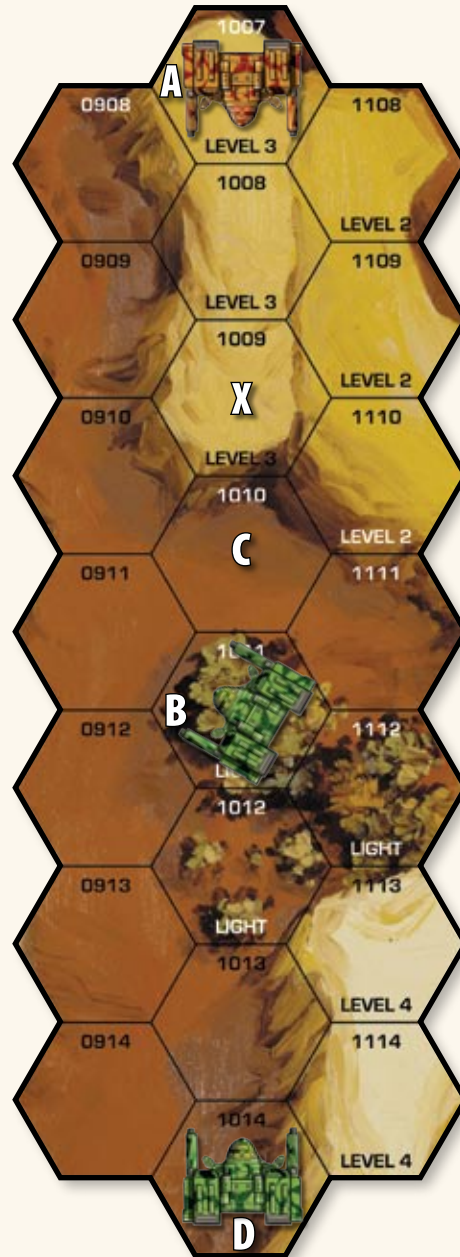

• LOS DEAD ZONE DIAGRAM 1 •

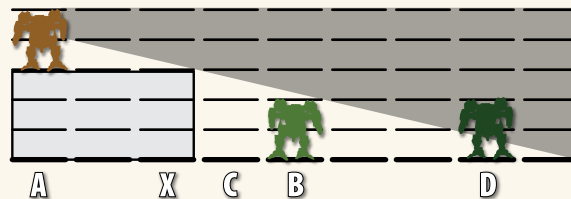

• LOS DEAD ZONE DIAGRAM 2 •

INTRODUCTION

ADVANCED  
GROUND MOVEMENT

ADVANCED  
COMBAT

ADVANCED  
BUILDINGS

ADVANCED  
SUPPORT  
VEHICLES

GENERAL  
RULES

ADVANCED  
SUPPORT VEHICLE  
CONSTRUCTION

ADVANCED  
WEAPONS  
AND EQUIPMENT

INDEX

RECORD SHEETS



If there is more than one of equally high levels, use the hex closest to the lower of the two units, designating it "Hex X." The level of Hex X may or may not create a dead zone. To find out, follow the steps shown below.

1. Subtract the level of the lower unit from that of Hex X. This number is "A."
2. Subtract the level of Hex X from that of the higher unit. This number is "B."
3. Subtract B from A and multiply the result by 2. This number is "C."
4. Count the range to Hex X from both units. Subtract the range to the lower unit from the range to the higher. This number will be negative if the higher unit is closer to Hex X than the lower unit. Add this number to C.

If the final result is greater than 0, the lower unit is in the dead zone and LOS is blocked. If the result is 0 or less, then LOS exists between the two units.

Using the previous example, the dead-zone rule works as follows. For the purposes of this rule, BattleMechs are considered to only be 1 level above the terrain on which they are standing (as opposed to the standard 2 levels), so the 'Mech in Hex B is at Level 1. Hex X is at Level 3.  $3 - 1 = 2$ , so "A" is 2. The 'Mech in Hex A is at Level 4;  $4 - 3 = 1$ , so "B" is 1.  $2 - 1 = 1$  and  $1 \times 2 = 2$ , so "C" is 2. The range from Hex X to both units is 2 hexes, and  $2 - 2 = 0$ . The final result is  $2 (2 + 0 = 2)$ . Because 2 is higher than 1, there is no LOS between the two units.

The Dead Zone rule does not change the way partial cover is determined.

*Consider the 'Mech in Hex D in the LOS Dead Zone diagram on p. 79. To find out whether it has LOS to the 'Mech in Hex A, subtract its level (Level 1) from 3 ( $3 - 1 = 2$ ;  $A = 2$ ). Next, subtract the level of Hex X (Level 3) from that of the higher unit ( $4 - 3 = 1$ ;  $B = 1$ ). Subtract B from A ( $2 - 1 = 1$ ), then multiply by 2 ( $1 \times 2 = 2$ ;  $C = 2$ ). The range to Hex X from the lower unit is 5; the range to the higher is 2 ( $5 - 2 = 3$ ). Add this to C ( $2 + 3 = 5$ ). The result is 5, which is less than 1, so LOS exists between the two 'Mechs.*



RA

*Black Widow Company and Bounty Hunter take the high ground.*

## Diagramming LOS

Some players might find it easier to diagram LOS between two units rather than using the formula provided for the Dead Zone rule.

To use the Line of Sight Chart found at the back of this rulebook, first determine the level of the attacking unit. The level of an attacking 'Mech is the level of the hex it occupies plus 2, to account for the 'Mech's height. Then plot the firing unit along the Level axis on the left side of the chart. Next, determine the target unit's distance from the attacker as well as its level, and plot it on the chart.

Then plot intervening terrain features between the two units.

Finally, use a straightedge and draw a line from the attacking 'Mech to the target on the chart to determine whether a clear LOS exists. (In the sample chart, the building interrupts the line, and so no LOS exists.)

See the Missed Shot LOS Chart, p. 83, for an example; the attacking unit is marked with an "F", while the target is marked with a "T".

**Line of Sight Chart:** The Line of Sight Chart at the back of the book is designed for players to photocopy, cut apart and paste together to cover truly large ranges, as needed.

## GLANCING/DIRECT BLOWS

Weapons fire in standard rules is almost always a straight-up hit or miss affair. However, not all shots are created equal. Some shots barely hit the target, while others are more perfectly center-lined. The following advanced rules reflect the differences that can exist even between multiple successful hits.

### Glancing Blow

Any time a dice roll result for a weapon or physical attack is exactly the number needed for the attack to strike its target, the hit is considered a glancing blow. For example, if you need to roll a 9 or better to hit the target, a result of 9 would be a glancing blow. A result of 10 or greater would be a normal hit.

A glancing blow inflicts half the normal damage against the target (rounded down). In the case of weapons that roll on the Cluster Hits Table, apply a -4 modifier to the dice roll result on the Cluster Hits Table. This modifier never reduces a roll on the table below 2.

A glancing blow is also less likely to cause critical damage. To reflect this, apply a -2 modifier to the die roll result on the Determining Critical Hits Table if a glancing blow yields the possibility of a critical hit; if using the Advanced Determining Critical Hits rule (see p. 74), apply a -4 modifier.

The Glancing Blow rule does not apply to damage that does not require a to-hit roll, such as falling damage. It also does not apply to non-damaging attacks such as TAG. All-or-nothing attacks such as Streak missile launchers cannot have glancing blows. If using the Linking Weapons rule (see p. 74), the entire linked group is considered a glancing blow.

**Conventional Infantry:** A glancing blow weapon attack from a non-infantry unit against conventional infantry is treated as the next row above on the Non-Infantry Weapon Damage Against Infantry Table (see p. 216, *TW*). For example, a medium pulse laser striking a glancing blow would be treated as a Cluster (Ballistic) attack. No attack can be moved above a Direct Fire (Ballistic or Energy) attack.



### Direct Blow

Any time a successful weapon or physical attack is made, the player should determine the Margin of Success (see p. 42, *TW*). For every MoS of 3, increase the Damage Value of the attack by 1; for weapons that roll on the Cluster Hits table, for every MoS of 3, apply a +2 modifier to the dice roll result on the Cluster Hits Table. The maximum Damage Value that can occur due to a direct blow is 2 times the standard Damage Value of the weapon. For example, a light machine gun making a direct blow would increase its standard Damage Value of 1 by 1, for a total Damage Value of 2. However, since that is the maximum increase that can occur, even if the MoS of the light machine gun attack was 6 or higher, the damage would remain at 2. However, a MoS of 6 for a heavy machine gun would increase the Damage Value from 3 to 5.

A direct blow is also more likely to inflict a critical hit. For every MoS of 3, apply a +1 modifier to the die roll result when determining critical hits; this applies whether using standard rules or the Advanced Determining Critical Hits rule (see p. 74).

**Automatic Hits:** If the Modified To-Hit Number is 2 or less for a given attack, the Target Number for the purposes of these rules would be 2. In this instance, the player would still roll the die, even if the strike is automatic, and compare the MoS against a Target Number of 2 to determine if a direct blow occurred.

**Conventional Infantry:** For every MoS of 3, treat a direct blow weapon attack from a non-infantry unit against conventional infantry as the next row down on the Non-Infantry Weapon Damage Against Infantry Table (see p. 216, *TW*). For each row "above" Cluster (Missile), roll 1D6 and add that number of troopers eliminated. For example, an LRM 20 direct blow with a MoS of 6 would first determine its standard damage ( $20 / 5 = 4$ ) and then would roll 2D6 (1D6 for each 3 MoS "above" Cluster (Missile)) and apply that die roll result to the 4 to determine the total number of eliminated troopers.

### MISSED SHOTS

In standard-rules *BattleTech*, a shot that misses the target simply vanishes (with the exception of some area-effect weapons, such as bombs). However, reality is more brutal and weapons always deal damage, often to friendly targets if they are too near when a missed shot occurs. Players have two ways to deal with missed shots: a somewhat more simplified rules set, and a rules set that builds on the initial rules and provides a more realistic way to determine missed shots.

Note that in a truly large game, numerous units may be intervening in the LOS between the attacker and target, so the use of this rule could greatly slow down game play. Players therefore may wish to only use this rule in smaller games (though ultimately, of course, it is up to each playing group to decide when and if they implement this rule).

**Swarm and I-Swarm:** Swarm and I-Swarm (see p. 371, respectively) follow their own rules for a missed shot.

### Determining Where a Missed Shot Hit

Whenever a weapon attack misses its target, note the die roll result, and then use the following rules to determine what it hit. In general the player will start at the hex closest to the target and then move backwards towards the attacker, using the various rules in this section to determine if a unit and/or terrain is struck in a given hex.

If a unit (friendly or enemy) is in the LOS between the attacker and target, and the unit is also a valid target, the attacking player should refigure the Modified To-Hit Number as though the attack is directed at that unit and compare that number to the original dice roll. Note that this "simplified" rules set does not take into consideration differences in the height of units, or differences in levels. Simply find the next appropriate unit that could have been a target and compare the newly figured Modified To-Hit Number against the original dice roll to determine if the attack struck the intervening unit as though it was the original target.

If more than one such unit is in the LOS between attacker and target, the player should begin with the unit closest to the original target. If more than one legal unit is in a hex (regardless of whether the units in question are friendly or enemy), randomly determine which unit to compare its Modified To-Hit Number against the original die roll first. If the new attack misses, the controlling player determines a new Modified To-Hit Number against the next unit, and so on.

If any woods/jungle hexes are between the attacker and a new target, and the Woods Cover rules (see p. 84) are in use, automatically apply the Woods Cover rule to those hexes if the shot strikes that new target; that is, treat each intervening jungle/woods hex as though the target occupied that hex for damage absorption. If several jungle/woods hexes intervene, each hex will absorb the damage as defined under that rule. This means that if the Damage Value of an attack drops to 0, the controlling player no longer needs to determine a new target for the missed shot. If a unit occupies a jungle/woods hex, apply the damage first to the hex, and then determine whether the attack strikes the target(s) in the hex. Note that such woods/jungle hexes only absorb damage if the target is struck.

If a level or building hex between the attacker and a target provided partial cover to a 'Mech (or hull-down to a vehicle, or hull down to a 'Mech, if the 'Mech is hull down), the controlling player should roll 2D6. On a result of 8 or higher, the attack strikes the terrain; in the case of weapons that roll on the Cluster Hits Table, the full Damage Value of the weapon is applied (if tracking damage to terrain; see *Terrain Factor Rules*, p. 64).

Note that there may be a mix of terrain types and/or units within the intervening LOS, requiring the players to switch through the rules above to ultimately determine the effect of a missed shot.

If no units and/or terrain are intervening between the attacker or target, or if the attacks against such units and/or terrain missed, or if there is damage left over after strikes against woods/jungle hexes, then the controlling player must move beyond the target to determine where the missed shot hit.

Draw a line between the attacker's hex and the target's hex, out to the edge of the playing area. Using the rules above, the controlling player should determine the ultimate resolution of any weapons that failed to strike the target in the hexes, along that LOS, beyond the target hex.

If any terrain equal to or higher than the target exists beyond the target (such as a hill or a building), the shot automatically strikes that terrain feature, dealing full damage (or whatever damage remains).

INTRODUCTION

ADVANCED  
GROUND MOVEMENT

ADVANCED  
COMBAT

ADVANCED  
BUILDINGS

ADVANCED  
SUPPORT  
VEHICLES

GENERAL  
RULES

ADVANCED  
SUPPORT VEHICLE  
CONSTRUCTION

ADVANCED  
WEAPONS  
AND EQUIPMENT

INDEX

RECORD SHEETS



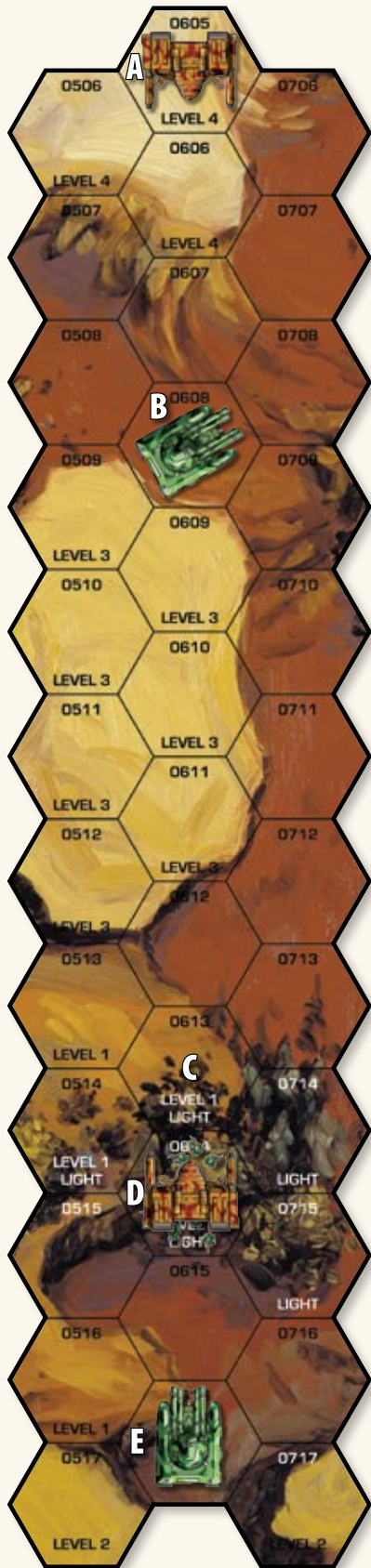

The Missed Shot rule automatically uses the Extreme and LOS Range rule (see p. 85). If a weapon does not strike any target and hits the edge of the playing area, any remaining damage is ignored. If a weapon cannot be used at LOS Range, and the weapon does not strike any target (either unit or terrain) and it hits its final extreme range hex, any remaining damage is ignored.

**Cluster Hits Weapons:** Note that all the rules above also apply to any damage that does not strike the target for weapons that roll on a Cluster Hits Table. For example, a controlling player makes a successful to-hit roll with an LRM 20 on the Cluster Hits Table, but only rolls a 5; 9 missiles struck the target. That leaves 11 missiles that didn't strike the target, so the player would use the rules noted above, rolling on the 11 column of the Cluster Hits Table if a new successful attack occurs.

**Aerospace Units:** Missed shots from airborne aerospace units against airborne aerospace units are simply ignored. Missed shots from airborne aerospace units against ground targets always strike the target hex, if tracking damage to terrain (see *Terrain Factor Rules*, p. 64) or are ignored; this does not include artillery or bombs, which use their own rules to determine where a missed shot lands.

*In the Missed Shot diagram, at left, on the Deep Canyon #1 map, the 'Mech in Hex A is firing a PPC and LRM 20 at the vehicle in Hex E. The PPC completely missed, while the LRM 20 struck the target vehicle, but only 9 missiles hit the target. The controlling player therefore needs to determine where the PPC hit, as well as the other 11 missiles from the LRM 20 that didn't strike the vehicle.*

*Starting back toward the attacking 'Mech from the target, along the LOS, the first potential targets are in Hex D. An enemy 'Mech and a friendly infantry unit occupy Hex D. As the missed shot doesn't care what is in the way, the controlling player randomly determines which unit the shot will attempt to strike first; he determines the infantry is up first. The controlling player must completely refigure the modified to-hit number as though the attack were originally against the infantry unit and compare that to the original die roll result. If that shot misses, the controlling player then completely refigures the modified to-hit number as though the 'Mech in Hex D were the target. If either of those shots hit, the player automatically subtracts 2 points of damage from the PPC and LRM 11 (the remaining missiles) for the intervening light woods in Hex C and then 2 more points of damage from the light woods in Hex D. This leaves the PPC with a Damage Value of 6 to inflict on the target, while the LRM 11 would be an LRM 7; the controlling player rolls on the 7 column of the Cluster Hits Table to determine how many missiles struck the target.*

*If neither target in Hex D is struck (or if some of the missiles from the "LRM 7" didn't strike the target after a roll on the Cluster Hits Table), the controlling player would move all the way back to the target in Hex B and completely refigure the modified to-hit number and once again compare it to the original die roll result. If that target missed, the player would then move beyond Hex E to any targets, along the LOS, out to the edge of the playing area. If there are no additional targets and/or terrain to hit before reaching the edge of the playing area (or the targets were missed), then the weapons deal no damage.*

• MISSED SHOT DIAGRAM •

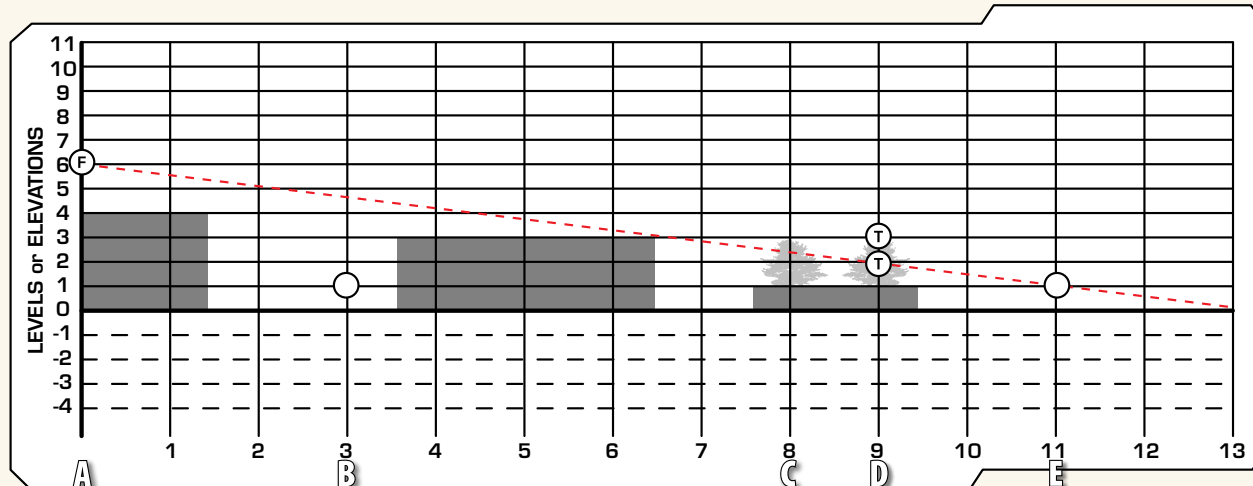

• MISSED SHOT LOS CHART •

**Level Difference**

In the more simplified rules above, differences in a unit's height and/or differences in level are ignored. However, the "true" LOS between the attacker and the target means that often units in the LOS would not be intervening and so there would be no way for a missed shot to strike those targets. While these rules are more complicated, they provide the most accurate way of determining what a missed shot strikes. While "realistic and accurate," the use of these rules will significantly increase the length of a game, so players may decide to restrict them to situations where the radical differences in terrain and units' heights make it hard to accurately eyeball events on the battlefield. For example, though fighting in a city is dealt with exactly like fighting in terrain, if combat is taking place on a truly large "city" playing area, with missed shots fired from units at radically different heights due to their location on top of tall buildings, these rules may be the most effective for determining where a missed shot hit, especially if players are using the expanded Construction Factor rules (see p. 121) where damage is tracked per level within a building hex.

Per *Diagramming LOS* (see p. 80), the controlling player should use the Line of Sight Chart (provided at the back of this rulebook) to graph out the various terrain features and units between the attacker and the original target along the LOS, and then draw the "true" LOS between the attacker and target using a straight edge (see the Missed Shot LOS Chart and example). Once the graph is completed, the players then use the rules under *Determining Where a Missed Shot Hit* as normal, but only those units and terrain features that fall within the LOS graphed on the chart are taken into consideration.

If there is damage remaining from the shot and it either goes up in the air above the playing area (for example, in the Missed Shot Diagram, if the vehicle in Hex E fired at the 'Mech in Hex A and the shot did not strike any terrain or units), or it strikes the underlying terrain of a hex (in the Line of Sight Chart, it strikes Hex 13), the damage is ignored; if players are using the *Terrain Factor Rules* (see p. 64), the damage from the attack that struck Hex 13 would be tracked, however.

Using the Missed Shot Diagram (see p. 82) as an example, graphing that situation would result in a graph as shown on the Missed Shot LOS Chart, above. This chart clearly shows that both the enemy 'Mech and friendly infantry in Hex D are in the LOS, and so as described in the Missed Shot Diagram example, the player would need to determine if the shot struck either target.

Unlike the *Determining Where a Missed Shot Hit* rules, where woods/jungle hexes only absorb damage if a "new target" is struck, if those rules are in use, any woods/jungle hexes intervening in the LOS as shown on the graph absorb damage; in this case, the woods in Hex C and D absorb damage from the missed shots, regardless of whether the targets in Hex D are hit.

If the missed shots do not hit either target in Hex D, the player would not move to the vehicle in Hex B, as it is clearly not intervening in the "true" LOS as shown on the graph. Instead, if the shots missed both targets, it would strike the ground in Hex 13 on the graph (off the diagram) and the damage would be ignored; or, if the players are tracking terrain damage under the *Terrain Factor Rules* (see p. 64), 13 points of damage [21 (PPC + 11 missiles) - 4 (2 points from each weapon for the light woods Hex C) - 4 (2 points from each weapon for the light woods Hex D) = 13] would be applied to Hex 13 on the graph.

**DAMAGE**

The following rules expand on the possibilities for damage inflicted by weapons, offering greater variety at the expense of simplicity.

**Altered Energy Weapon Damage**

Due to the constraints of focusing, energy weapons can lose effectiveness over their range.

The Altered Energy Weapon Damage rule decreases or increases Direct-Fire Energy and Pulse weapons damage depending on the distance between the attacker and the target. Damage inflicted at long range decreases by 1 point. For attacks against very close targets (which are a bit more effective), increase the damage done by 1 point for targets in the same hex as or in a hex immediately adjacent to the attacker.

INTRODUCTION

ADVANCED GROUND MOVEMENT



ADVANCED COMBAT

ADVANCED BUILDINGS

ADVANCED SUPPORT VEHICLES

GENERAL RULES

ADVANCED SUPPORT VEHICLE CONSTRUCTION

ADVANCED WEAPONS AND EQUIPMENT

INDEX

RECORD SHEETS



### Woods Cover

Woods can provide protection from an attack in much the same way as a building, in that shots will sometimes strike trees and overgrowth instead of the intended target.

When using the Woods Cover rule, woods in the target unit's hex do not provide the usual to-hit modifier for terrain. Instead, the woods hex absorbs damage from any type of weapon attack. A light woods/jungle hex absorbs 2 points of damage, a heavy woods/jungle hex absorbs 4 points of damage, while an ultra woods/jungle hex absorbs 6 points of damage. The woods will absorb damage from each attack into its hex, in a manner similar to the way buildings absorb damage (see *Attacking Units Inside Buildings*, p.171, *TW*).

Remember to track damage applied to such a hex in this fashion for the purposes of clearing (see *Clearing Woods*, p. 112, *TW*). Woods cover only applies to woods occupied by the target hex; intervening woods simply inflict the standard to-hit modifiers rather than absorbing damage.

### Cluster Hit Penalties

This optional rule reflects the fact that for some weapons that roll on the Cluster Hit Table (missiles, LB-X and so on), the damage spread increases at a certain range, reducing the number of hits that will strike the target at longer ranges. This rule does not apply to Streak or LRM missile launchers, or to standard/extended-range missiles from an ATM launcher.

For any HAG, LB-X, SRM, MRM or HE ATM, against targets at long range, apply a -1 modifier to the result of the die roll on the Cluster Hits Table. Add a +1 modifier to the die roll against targets in the same hex as or hexes adjacent to the attacker. In all instances, this is in addition to any other modifiers that may affect this die roll result. These modifiers never reduce a roll on the table below 2, or above 12.

### ADVANCED FIRING

The following rules explain special firing stances and modes.

#### Attacks Against Large Infantry Formations

When more than a single infantry unit is located in a hex, this increases the likelihood of an attack hitting a unit...just not exactly the unit the attacker was attempting to hit. Whenever more than one conventional infantry platoon occupies the same hex, use the following rule.

For each additional conventional infantry platoon that occupies the hex, apply a -1 to-hit modifier. Then randomly determine the actual target hit. For example, a hex is occupied by two friendly and two enemy infantry platoons. A -3 to-hit modifier would be applied to any weapon attacks against any of the four units occupying the hex. However, if the to-hit roll is successful, the attacking player would randomly determine which of the four infantry units is actually hit.

Note that these modifiers only apply if a platoon has at least 21 active troopers. If the platoon has less than 21 active troopers, then that additional modifier does not apply. However, the platoon can still be the accidental target of an attack. For example, a battle armor unit, a platoon with 18 active troopers, a platoon with 21 active troopers and a platoon with 28 active troopers occupy the same hex. Regardless of the unit targeted, only a -1 to-hit modifier applies; there are two platoons with at least 21

troopers active, which activates this rule, but the platoon with only 18 active troopers and the battle armor squad provide no additional modifiers. However, because the rule is activated, if a successful attack is made, the attacking player would randomly determine which of the four infantry units is struck.

### Bracing

A 'Mech may gain additional accuracy when firing weapons by bracing itself against a hill or building, much like a twelve-meter-tall sniper. A 'Mech may also combine bracing with careful aim (below) or bracing with careful aim and opportunity fire (see p. 86) for deadly accurate shots.

The 'Mech may only brace a single arm against the hex directly in front of it, which must be 1 level higher than the level of the underlying terrain of the hex occupied by the 'Mech. The bracing action is executed during the Movement Phase of a turn and costs 1 MP; a 'Mech expending Jumping MP cannot brace in that turn (i.e. the 'Mech would need to wait until the following turn and only expend Walking/Running MP to brace).

While bracing, the 'Mech is considered an immobile target; it cannot move or make physical attacks. A bracing 'Mech may not fire leg- or front-torso-mounted weapons or weapons in the un-braced arm. The 'Mech may not torso twist, and weapons in the braced arm may only fire at targets in the front firing arc. The 'Mech may only fire weapons mounted in the braced arm.

Apply a -2 to-hit modifier to all attacks made with the weapons in the braced arm.

A bracing 'Mech is considered to be taking cover behind the hex against which it is bracing (see *Taking Cover*, p. 88). A four-legged 'Mech cannot brace because it has no arms. A bracing 'Mech may stop bracing during any subsequent Movement Phase simply by moving. Ending a bracing action costs no MP.

**Actuator Damage:** Modifiers from actuator damage in a braced arm are ignored.

**ProtoMechs:** ProtoMechs may brace their main guns, but do not require any terrain to do so. Instead, the player simply nominates a ProtoMech as "bracing" at the end of its movement. A ProtoMech that is bracing is considered an immobile target during any turn it is bracing. Apply a -2 to-hit modifier to any attack made by the main gun; the ProtoMech can only make attacks with the main gun in a turn it is bracing.

### Careful Aim

Instead of firing its weapons, a unit can spend the Weapon Attack Phase of a turn taking careful aim on a single target within its line of sight. While taking careful aim, the unit may make neither weapon nor physical attacks, nor may it expend MP.

For every consecutive Weapon Attack Phase the unit spends taking careful aim, apply a -1 to-hit modifier to any weapon attacks against the chosen target (to a maximum of -3). Once the unit attacks, it uses up this bonus. If the aiming unit moves, switches targets or fails a Piloting Skill Roll, or if the target moves out of LOS before any weapon attacks are made, careful aim is interrupted and any accumulated bonus is lost.

**Pulse/Rapid-Fire/LB-X/HAG:** Pulse, Rapid-Fire (when firing more than one shot), LB-X (when firing cluster rounds) and Hyper-Assault Gauss rifle weapons cannot make use of careful aim.

**Targeting Computers:** Targeting computers apply their standard modifier when used in conjunction with careful aim.



## Extreme Range

Ranged weapons can fire at targets beyond long range, but such shots are difficult.

Use the following rules for Extreme Range.

- Extreme Range starts 1 hex beyond long range and extends to a range equal to the weapon's maximum medium range times 2. For example, extreme range for a medium laser extends from 10 to 12 hexes; the medium laser's long range is 9 (9 + 1 = 10), and its maximum medium range is 6 (6 x 2 = 12). For Variable Range weapons, multiply the Long Range by 1.5 (round down). If a weapon does not have a Long Range, it cannot have an Extreme Range.
- Apply a +6 to-hit modifier to any weapon attacks against targets at extreme range.
- For any weapon that rolls on the Cluster Hits Table, apply a -2 modifier to the die roll result when rolling on the Cluster Hits Table (this is in addition to any other modifiers that may affect this die roll result). These modifiers never reduce a roll on the table below 2.
- Divide the Damage Value of any Pulse Weapon by 2, rounding down.
- Subtract 1 point of damage from any Direct-Fire Energy weapon or any weapon with the word "Gauss" in its name (except HAGs).
- Multiply the Damage Value of any Direct-Fire Ballistic (but not Gauss) weapons by .75 (rounding down).
- For Variable Damage weapons, use the long range Damage Value when determining the Extreme Range Damage Value.
- In the case of special rules that use range as a determining factor and do not specifically mention extreme range, treat extreme-range attacks in the same way as long-range attacks; i.e. any long range modifiers are also applied to extreme range. For example, the null-signature system (see, p. 336) increases the modifier for long-range attacks by +2 to a total of +6. As such, for extreme range attacks, a +2 modifier would be added to the standard +6 extreme range modifier, for a total modifier of +8. Finally, as it is impossible to consider every case in the space available, the players' judgment must prevail on occasion.
- Any weapon attack from a weapon at Extreme Range using a C<sup>3</sup> System adds 1 range bracket beyond the closest friendly unit in the C<sup>3</sup> system. For example, if a weapon is firing at Extreme Range and the closest friendly unit is at Short Range, the firing unit would determine the final Modified To-Hit Number as though the closest friendly unit was at Medium Range.

## LOS Range

For those playing truly large games across dozens of maps, players can institute LOS Range. Note that for added realism, players can use the LOS Range rule in conjunction with the Visual Range Table found in the Double Blind rules (see p. 221), to provide a "hard number" of hexes that a player can visually see under a variety of Planetary Conditions: if you can see it, you can try to make an attack.

Use the following rules for LOS range.

- LOS Range starts 1 hex beyond extreme range and extends to the limits of the entire playing area, regardless of how large.

- Apply a +8 to-hit modifier for any weapon attacks against targets made at LOS range.
- Any Direct-Fire Ballistic or Missile weapon with a Long range of less than 13 hexes cannot make use of LOS range.
- Any Direct-Fire Energy or Pulse weapon with a Long range of less than 7 hexes cannot make use of LOS Range.
- For any weapon that rolls on the Cluster Hits Table, apply a -3 modifier to the die roll result when rolling on the Cluster Hits Table (this is in addition to any other modifiers that may affect this die roll result). These modifiers never reduce a roll on the table below 2.
- Divide the Damage Value of any Pulse Weapon by 3, rounding down.
- Divide the Damage Value of any Direct-Fire Ballistic (but not Gauss) weapons by 2, rounding down.
- Multiply the Damage Value of any Direct-Fire Energy weapon, or any weapon with the word "Gauss" in its name (except HAGs), by .75 (rounding down).
- For Variable Damage weapons, use the long range Damage Value when determining the LOS Range Damage Value.
- As with extreme range, treat LOS Range attacks as long range attacks for any situations where range is a determining factor; i.e. any long range modifiers are applied to LOS Range. In the null-signature system example above, an additional +2 would be added, making the LOS Range modifier +10.
- Note that any C<sup>3</sup> System is incompatible with LOS Range. If a weapon is firing at LOS Range, it cannot make use of a C<sup>3</sup> network.

## Firing When Down

Under standard rules, a prone 'Mech may only fire if neither of its arms has been destroyed. Advanced rules allow a prone 'Mech with one arm destroyed to prop itself up on its intact arm and fire any non-limb mounted weapons. Apply an additional +1 modifier (beyond the standard prone modifier) to all shots made while prone to reflect the damaged 'Mech's reduced stability. Any actuator damage modifiers are also added.

## Linking Weapons

Before the game begins, and also during the End Phase of any turn, a player may designate certain weapons to be linked on his units (this can be any non-infantry unit). Any or all weapons on a single unit can be linked, but they must be able to fire into the same firing arcs. A unit may also have more than one linked group of weapons. For example, a ALB-3U *Albatross* may link the large pulse laser and two medium lasers in its right arm into "link 1", the SRM 6, LRM 15 and ER Large Laser in the torsos into a "link 2" and finally, since only the LB 10-X AC is the only weapon mounted in the left arm, it is in its own "link 3." Additionally, provided the rules above are adhered to, a weapon can be a part of multiple links. Linked weapons must be clearly indicated on a unit's record sheet.

Linked weapons must always be fired at the same target, though all linked weapons in a given group need not fire every time (for example if a target is out of range of some weapons in a link, those shorter-ranged weapons need not be fired at the target, but they cannot be fired at any other target). The controlling player makes only one to-hit roll for the entire

INTRODUCTION

ADVANCED  
GROUND MOVEMENT

ADVANCED  
COMBAT

ADVANCED  
BUILDINGS

ADVANCED  
SUPPORT  
VEHICLES

GENERAL  
RULES

ADVANCED  
SUPPORT VEHICLE  
CONSTRUCTION

ADVANCED  
WEAPONS  
AND EQUIPMENT

INDEX

RECORD SHEETS





group of linked weapons. The to-hit number for the group is determined according to the worst range and other modifiers in the group. For example if a large pulse laser and a medium laser were in a link together and the target was in range of the medium laser, then the to-hit modifier would be determined based upon the medium laser (i.e. its shorter range, no pulse modifier would be applied and so on). If the roll fails, all the linked weapons miss. If it succeeds, all the linked weapons hit. Hit location is determined normally for each individual weapon in the linked group.

### Opportunity Fire

Instead of attacking during the Weapon Attack Phase of a turn, a unit may elect to watch for enemy units to come closer or into line of sight and then launch an attack immediately. Such attacks are called opportunity fire. Players should note that opportunity fire can make the game much more complicated because it allows attacks to be made outside the normal sequence of play. Players should carefully consider the impact of this optional rule before incorporating it into their game.

During any Weapon Attack Phase, in place of making a weapon attack, a controlling player may announce the unit is in "Over-watch" mode. From that point on, the unit's player watches for a chance to strike, and the unit may not move or make any attacks until the controlling player announces that he is taking opportunity fire.

At any time during the Movement Phase of any subsequent turn, a player controlling any unit previously said to be in Over-watch mode can announce opportunity fire. A player can even announce opportunity fire in the middle of a target's movement, allowing him to attack a unit dashing from one area of cover to another. Opportunity fire may only be used against targets in the front firing arc, and the attacking unit cannot torso twist or rotate its turret.

Opportunity fire is resolved immediately in the same Movement Phase. If two or more units wish to use opportunity fire at the same time, resolve the attacks in the order in which they were announced. If the players cannot agree on which attack was announced first, roll a die to determine which player starts. On a result of 1-3, Player A goes first; on a result of 4-6, Player B goes first.

Opportunity fire works like other types of attack, except that all such attacks include an additional +2 to-hit modifier to reflect the speed at which the shot must be made. The target movement modifier is based on the movement of the target up to the point at which it is attacked. Once a unit announces opportunity fire, it may attack with any and all of its weapons, but must make all attacks immediately; any damage, and Piloting Skill Rolls required due to damage, are resolved immediately. The unit may not move or make any weapon attacks for the remainder of the turn, though the unit may make physical attacks. A unit in over-watch that makes any attacks using opportunity fire cannot be declared to be in "Over-watch" mode again until the following turn's Weapon Attack Phase.

A unit may also make physical attacks as opportunity fire. The controlling player must choose one type of attack or the other, and in either case the unit ceases watching after the attack is made.

Damage from opportunity fire takes effect immediately. If the attack forces the target's player to make a Piloting Skill Roll, he must do so immediately following the attack. Once the attack is over, the target finishes its movement (if possible) and the Move-

ment Phase continues normally; if the 'Mech fell due to a failed Piloting Skill Roll due to damage, provided it still had MPs available, it could attempt to stand and continue moving.

Instead of announcing opportunity fire, a watching unit may move during the Movement Phase (unless its controlling player declares that it is still watching). A 'Mech that moves is no longer in Over-watch mode for opportunity fire.

**Jumping 'Mechs:** A 'Mech that is jumping that is the target of opportunity fire that fails a Piloting Skill Roll caused by that fire falls into the hex it occupied when the attack was made. Resolve any falling damage, displacement and so on that might occur due to such an un-intended fall. The jumping 'Mech's movement is over.

### Opportunity Fire: Firing on the Move

In standard rules, all units move and then all units fire. However, the ability to snap off a quick shot as a unit moves from cover to cover can often be a valid and crucial tactic. As with the Opportunity Fire rules (above), the ability to interrupt movement with weapon attacks can significantly increase not only the complexity, but the length of a game, so all players should firmly review this rule before deciding to add it to a game.

During the Movement Phase, a controlling player can announce at any time (either before MP are spent, during the expenditure of MP, or after all MP have been spent) that the unit being moved is making a weapon attack. Only 1 weapon can be fired using this rule. The weapon must fire into its standard firing arc. No torso or turret twisting is allowed, so a front torso-mounted weapon could only fire into the front arc, while a right arm-mounted weapon could fire into the front arc and right-side arc.

Apply a +3 modifier (in addition to all other standard modifiers) to reflect the nature of the rapidly taken shot. If the target has already moved in the current Movement Phase, then apply the standard target movement modifier; if the target has not yet moved, then no target movement modifier is applied.

This means that a unit expending Jumping MP (infantry, a jumping 'Mech, and so on) can make an attack while jumping. In this case, both modifiers would apply: the +3 for jumping and the +3 for the Firing on the Move, as well as any other applicable modifiers.

Any damage inflicted against the target is resolved immediately, with any required Piloting Skill Rolls also made immediately.

**Infantry:** Infantry apply a +1 to-hit modifier unless jumping; then a +3 to-hit modifier applies. This is in addition to the +3 Firing on the Move modifier.

**VTOL Vehicle:** If a VTOL Vehicle does not enter a new hex at any point in a Movement Phase, then its standard attacker movement modifier is not applied when making a Firing on the Move attack in that Movement Phase; in other words, the unit is only moving vertically within the hex (any weapon attacks against such a unit would only apply a +1 modifier for an airborne unit and would not have any additional target movement modifiers).

**Linking Weapons:** If using the Linking Weapons rule (see p. 85), a series of linked weapons can be fired in this fashion. However, all linked weapons must be in the same location (note this restriction is more stringent than the standard linking restriction of "the same firing arc").

**Physical Attacks:** While this type of attack can be made in the same turn that an attacking unit is making a charging (ram) or death-from-above attack, apply a +2 to-hit modifier to the physical

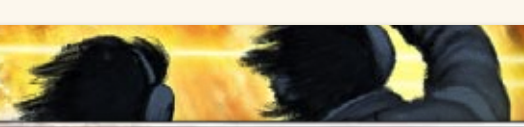



attack in question in order to reflect the difficulty of trying to fire on the run while making such a difficult physical attack.

**“Popping Up”:** Any non-Mech unit expending Jumping MP can stay in its hex and simply move vertically up and down to make use of this rule; on the other hand, a Mech must enter a new hex for each Jumping MP it expends and so cannot simply “pop up” in the same hex using Jumping MP.

### Expanded Reversing (Flipping) Arms

In standard rules, a Mech cannot torso twist and reverse its arms. However, this can occur under advanced rules. The player must announce whether a Mech is torso twisting or reversing its arm first. Then the controlling player makes a standard Piloting Skill Roll, applying all standard modifiers. If it is successful, then the secondary move can be made. If it fails, it does not result in a fall. Instead, the second move (whether a torso twist or reversing arms) simply cannot be made.

### Suppressing Fire

In place of a standard attack, a unit can use suppressing fire in an attempt to pin an infantry unit in place. The use of this rule requires the use of the Morale rules as well (see p. 21).

Before making a weapon attack, the controlling player must announce that in place of a weapon attack, a suppressing fire attack is being made. The attack is made against the hex where the infantry is located (whether in woods, in a building and so on). If the attack is successful (if using the Fumble rules, a result of 2 is a miss and the suppressing fire doesn't force a roll; see p. 75), no damage is applied against any infantry units occupying that hex (though damage can be applied to the hex, if players are tracking damage: a building hex, the terrain [see *Terrain Factor Rules*, p. 64] and so on). Instead, any infantry units (friendly or enemy) in that hex must make a Morale Check at the end of the Weapon Attack Phase, applying the modifiers from the Suppressing Fire Table, as well as all appropriate modifiers from the Morale Tables (see p. 212). If the unit fails the Morale Check, it is not broken; none of the standard effects for a failed Morale Check apply. Instead, any infantry units in the hex cannot expend MP in the subsequent turn's Movement Phase, and apply a +1 to-hit modifier to all weapon attacks by battle armor and a +2 to-hit modifier to all weapon attacks by conventional infantry in that turn's Weapon Attack Phase as well.

Regardless of how many suppressing-fire weapon attacks are directed at a hex in a turn, each infantry unit in a hex

can never make more than a single Morale Check against suppressing fire in a turn. The highest modifier as shown on the Suppressing Fire Table is applied, with each additional weapon that would normally apply a modifier higher than 0 applying a +1. For example, a flamer, heavy machine gun, SRM 6, PPC and medium pulse laser are announced as engaging in suppressing fire against a target hex. The highest-modifier weapon on the Suppressing Fire Table is the flamer at +3. Neither the PPC (Direct Fire Energy) nor the medium pulse laser (Pulse) provide a modifier above 0. Therefore, though they both would cause a Morale Check for suppressing fire on their own, they do not add an additional modifier in this case. The SRM 6 (Cluster Missile) and the heavy machine gun (additional weapon beyond first), however, both apply a +1 modifier, for a total of +6, which will be added to any applicable modifier from the Morale Check Table.

**Airborne Infantry:** Suppressing fire against airborne infantry (for example, infantry expending VTOL MP) cannot be made.

### PARTIAL COVER

The following rules expand on partial cover. Like other advanced rules, they increase realism at the expense of simplicity.

#### Expanded Partial Cover

Expanded partial cover allows a unit to have 1/4 cover, 3/4 cover and vertical cover in addition to the horizontal partial cover permitted under standard rules.

If the line of sight for an attack passes directly through the line between two hexes, the target normally chooses the attack direction. Under the expanded partial cover rules, the attack enters the target hex through the corner, and levels in either hex may provide partial cover to the target.

If both hexes adjacent to the line of sight and the target are one level higher than the level of the underlying hex the target occupies, the terrain provides standard partial cover.

If one hex's level is equal to the level of the underlying hex the target occupies and one hex is one level higher than the level of the underlying hex the target occupies, the target has 1/4 cover. An attack against such a target has no partial-cover modifier. If the hit location roll result indicates a leg hit on the covered side, the shot hits the cover rather than the Mech.

If one hex's level is equal to the level of the underlying hex the target occupies and one hex is equal to the level of the target, the target is in vertical cover. The partial-cover modifier is the standard +1, and any hit locations rolled against the covered side (arm, leg, or torso, but not center torso or head) strike the cover.

If one hex is one level higher than the level of the underlying hex the target occupies and one hex is equal to the level of the target, the target has 3/4 cover. The partial-cover modifier is the standard +1 and any hits on the legs or the covered side strike the cover.

If the attacker is at a higher level than the target, 1/4 and horizontal cover do not apply unless the target is actually taking cover (see *Taking Cover*, p. 88). A target can use vertical cover as long as the attacker is not higher than the terrain that provides it. Three-quarter cover is considered vertical cover if the attacker is higher than the target; if the attacker is higher than the hex providing 3/4 cover, such cover does not apply.

## SUPPRESSING FIRE TABLE

Weapon Type	Modifier
Direct Fire (Ballistic or Energy), Cluster (Ballistic), Pulse	+0
Cluster (Missile)	+1
Burst Fire Weapon: 1D6 or 2D6	+2
Burst fire Weapon: 3D6 or 4D6+	+3
Area-Effect	+4
Additional Weapons Beyond First	+1

INTRODUCTION

ADVANCED  
GROUND MOVEMENT

ADVANCED  
COMBAT

ADVANCED  
BUILDINGS

ADVANCED  
SUPPORT  
VEHICLES

GENERAL  
RULES

ADVANCED  
SUPPORT VEHICLE  
CONSTRUCTION

ADVANCED  
WEAPONS  
AND EQUIPMENT

INDEX

RECORD SHEETS



# PHYSICAL COMBAT

The following optional rules relate to physical combat.

## WEIGHT CLASS PHYSICAL ATTACK MODIFIERS

In standard rules, all units are considered equal when it comes to making physical attacks. However, despite the increased gyro size of many larger units, it is easier to control a lighter-weight 'Mech than a heavier one when it comes to the extra agility required to make physical attacks.

Whenever a unit makes any type of physical attack, consult the Weight Class Physical Attack Modifiers Table (below) and apply the appropriate modifier based on the weight of the unit; this is in addition to all other standard modifiers. Note that these modifiers ONLY apply to the physical attack itself. Any Piloting Skill Rolls required due to the success or failure of a physical attack do not apply these additional modifiers (see p. 23).

## WEIGHT CLASS PHYSICAL ATTACK MODIFIERS TABLE

Weight Class	Modifier
Light (Ultra-Light)	-2
Medium	-1
Heavy/Assault	+0

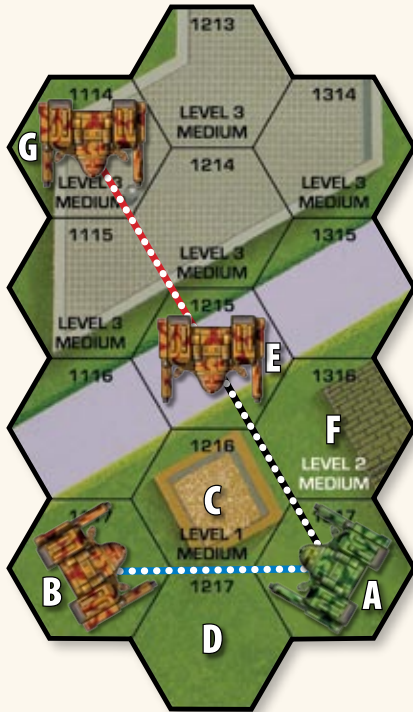

• EXPANDED PARTIAL COVER DIAGRAM •

In the Expanded Partial Cover Diagram, above, the 'Mech in Hex A on the City (Skyscraper) map is under attack by three other 'Mechs. The 'Mech in Hex B is attacking against 1/4 cover, as the building in Hex C is Level 1 and Hex D is Level 0. Any shots by the Hex B 'Mech that result in a right-leg hit location miss the target 'Mech and strike the covering building instead.

The 'Mech in Hex E is attacking against 3/4 cover, because the building in Hex F is equal in height to the 'Mech in Hex A and the building in Hex C provides partial cover to the target 'Mech. Hits on the right leg, arm or torso will hit the building in Hex F, while hits on the left leg will hit the building in Hex C.

The 'Mech in Hex G is on a Level 3 building, making it Level 5. Though it is higher than the building in Hex F, the target is equal in height and adjacent to the building in Hex F and so the 'Mech in Hex G must still attack against vertical cover on the target's right side. Such cover does not protect the target on the bottom left side, however, as the Hex G 'Mech is high enough to shoot over the Level 1 building in Hex C.

### Taking Cover

A 'Mech can move to the edge of the hex it is occupying to actively "take cover," gaining partial cover through a single chosen hexside regardless of the attacker's level. Naturally, the hex behind which the target takes cover must be half the level of the 'Mech—that is, one level higher than the underlying terrain in the hex in which the 'Mech is standing. The hexside must be chosen at the beginning of the Weapon Attack Phase, and a unit taking cover may not torso twist.

**Reversing Arm:** A 'Mech that is taking cover can reverse its arms.

## NEW PHYSICAL ATTACK WEAPONS

The *Advanced Weapons and Equipment* section contains numerous experimental weapons that can be used in physical weapon attacks. The complete rules for their use are found under *BattleMech Melee Weapons*, p. 288. The Physical Weapon Attacks Addendum Table (see p. 87) provides a cheat sheet for those weapons, presented in the same format as the standard-rules physical attack weapons (see Physical Weapon Attacks Table, p. 146, TW).

## NEW ATTACK TYPES

The following rules describe some new types of physical attacks. Unless otherwise noted, standard rules for physical attacks apply (see p. 144, TW).

### Blocking a Physical Attack

Not really a new type of physical attack, this rule allows a player to potentially lessen the amount of damage from a physical attack, as well as deciding where the attack will land.

The following rule only applies to incoming punch, club, physical weapon and kick attacks. A player cannot use this rule to block any other type of physical attack.

Whenever a punch, club or physical weapon attack is announced against a target 'Mech, the controlling player of the target 'Mech can attempt to block with the right arm or the left arm that has not already been declared as making an attack; a block with both arms cannot be made against the same attack. However, a player can block two different attacks, one arm to each attack, provided all the appropriate criteria under these rules are met. The player



## PHYSICAL WEAPON ATTACKS ADDENDUM TABLE

Weapon Type	To-Hit Modifier	Damage Value	To-Hit Location Table	Firing Arc**	Affected by TSM	To-Hit/Damage Value Affected by Actuator Damage
Chain Whip	-2	1/per 10 tons +1‡	Standard	Arm	No	Yes/No
Claws	+1	1/per 7 tons‡‡	Punch	Arm	Yes	Yes/Yes
Flail	+1	9	Standard	Arm	No	Yes/No
Lance	+1	1/per 5 tons††	Standard	Arm	Yes	Yes/Yes
Mace	+2	1/per 4 tons***	Standard*	Arm	Yes	Yes/Yes
Shields	†	†	Standard	Arm	No	Yes/No
Vibroblade						
Deactivated	-2	1/per 10 tons + 1‡	Standard*	Arm	Yes	Yes/Yes
Activated	-2	§	Standard*	Arm	No	Yes/No

\*Roll normally on the 'Mech Hit Location Table. Alternatively, when the controlling player announces the physical weapon attack, he may also announce that he will use the Punch or Kick Hit Location Table to resolve damage if the attack succeeds, in which case apply a +4 modifier in addition to all the standard modifiers, including the standard to-hit modifier for the weapon (this modifier does not apply when attacking on the Punch/Kick Location Table due to attacks from different levels; see p. 150, *TW*).

\*\*The target of the physical weapon attack can be in the 'Mech's forward arc or in the side arc corresponding to the arm in which the equipment is mounted.

\*\*\*A successful attack does 1 point of damage for every 4 tons that the attacking 'Mech weighs (round up).

†See *Shield*, p. 290

††A successful attack does 1 point of damage for every 5 tons that the attacking 'Mech weighs and may damage the internal structure of the target.

‡A successful attack does 1 point of damage for every 10 tons that the attacking 'Mech weighs (round up), + 1.

‡‡A successful attack does 1 point of damage for every 7 tons that the attacking 'Mech weighs (round up).

§See *Vibroblade*, p. 292

can also block with one arm and make a standard attack with the other arm. In both situations the player must nominate one arm as the "primary" arm, adding an additional +1 modifier to the "secondary" arm, regardless of what actions are taken. For example the player may nominate a left arm that is blocking an attack as the "primary arm" and then launch a punch attack with the right arm as the "secondary arm," applying a +1 to-hit modifier, in addition to all other modifiers. A unit cannot block a punch, club or physical weapon attack and make any other type of physical attack except for a punch as noted above.

If weapon attacks by weapons in a arm were made in the same turn, that arm cannot be used for blocking; the arm also cannot be used to launch a physical attack in the same turn it is used to block. Finally, the physical attack must originate in the arm's arc used for the block; for example, an attack on the left side of a 'Mech could not be blocked by the right arm.

Once a successful punch, club or physical weapon attack is made, the controlling player of the blocking unit makes a Piloting Skill Roll. All standard modifiers apply (including damage to actuators in the blocking arm, as well as other damage, and so on). Additionally, compare the Piloting Skill Ratings of the attacking and blocking units, using the difference between the two skill ratings as a modifier to the to-hit number. If the attacker's skill rating is lower, add the modifier to the to-hit number. If the blocker's Piloting Skill Rating is lower, subtract the modifier from the to-hit number. A failed Piloting Skill Roll means the attack proceeds as normal; the block failed and the unit cannot attempt to make an attack with that arm this turn. A successful Piloting Skill Roll means that the attack has been successfully blocked; halve the damage, rounding down,

from the punch, club or physical weapon attack and apply that against the arm that blocked the attack. Finally, for each 2 MoS, subtract 1 point of damage from the attack; damage can never be reduced below 1. For example if the Target Number of the Piloting Skill Roll is 7 and the die roll result is 11, that provides a MoS of 4 and so an additional 2 points of damage would be subtracted from the physical attack, after the damage from the initial attack is halved.

The same rules apply for blocking a kicking attack with a leg, except that only kicking attacks from the front arc can be blocked. If the blocking 'Mech fails its Piloting Skill Roll to block a kick, it must roll another Piloting Skill Roll; this is in addition to the roll for being kicked or any Piloting Skill Rolls that might be required due to damage (as usual, all modifiers apply to all the Piloting Skill Rolls, including the one for having missed blocking a kick). If a unit blocks a kick, it cannot block a punch, club or physical weapon attack in the same turn.

**Physical Weapons:** If a 'Mech mounts a physical weapon (that is, a physical weapon that can be used to make a damaging attack), it can use the weapon to attempt to parry a physical attack, not just block it. In addition to all the standard modifiers described above, apply the appropriate to-hit modifiers for the weapon in question from the Physical Weapon Attacks Table (see p. 146, *TW*) or the Physical Weapon Attacks Table Addendum (above). If the parry is successful, no damage is dealt.

**Shields:** If a unit mounts a shield (see p. 290) and successfully blocks, the damage is applied to the shield; shields cannot be used to parry an attack, as described under *Physical Weapons* above.

INTRODUCTION

ADVANCED  
GROUND MOVEMENT

ADVANCED  
COMBAT

ADVANCED  
BUILDINGS

ADVANCED  
SUPPORT  
VEHICLES

GENERAL  
RULES

ADVANCED  
SUPPORT VEHICLE  
CONSTRUCTION

ADVANCED  
WEAPONS  
AND EQUIPMENT

INDEX

RECORD SHEETS



**Weight Class Piloting Skill Roll Modifiers:** The Weight Class Physical Attack Modifiers Table (see p. 88) apply when attempting to block an attack.

**Different Levels:** A punch/physical weapon or kick attack can be blocked by either a leg or an arm, depending on the differences in levels (see Different Levels Table, p. 150, *TW*).

### Grabbing

Only 'Mechs with at least one undamaged hand actuator (or claw) may attempt a grabbing attack. Rather than inflicting damage, this type of attack is intended to take away an object that the target is holding, such as a handheld weapon (see p. 315), unprotected cargo or certain items that must be carried in "capture-the-flag" scenarios. This type of attack cannot be used to grab items that only have the appearance of being hand-held, such as hatchets and certain arm-mounted weapons, which are actually part of the 'Mech. If an item occupies critical slots, it cannot be grabbed.

The attacker must announce what he is attempting to grab during weapon attack declaration, and may make no weapon attacks with the grabbing arm during the turn. The grab is treated as a punch attack (see p. 145, *TW*), with an additional +1 to-hit modifier. If the attack is successful, the attacking 'Mech grabs the desired object, provided the 'Mech is strong enough to carry it (see *'Mech Lifting Capabilities*, p. 261, *TW*). If the attacking 'Mech is not strong enough to carry the object, the attack knocks it out of the target's grasp and it falls to the ground in the hex the attacker occupies.

**Grabbing Turrets:** If a 'Mech is in the same hex as a vehicle with a turret in the Physical Attack Phase, the 'Mech can make a grabbing attack to grab hold of the turret, though a 'Mech attempting such a grabbing attack must have two functioning hand actuators; only a single grabbing turret attack can be made against a vehicle per turn. If the attack is successful, the 'Mech has grabbed hold of the turret. The player then immediately makes another Piloting Skill Roll with an additional +3 to-hit modifier, while also applying the following additional weight-class modifiers: light +1, medium +0, heavy -1, assault -2. Activated triple-strength myomer also applies a -2 modifier. A failure has no effect. A successful Piloting Skill Roll automatically forces the vehicle's controlling player to roll once on the Turret column of the Ground Combat Vehicle Critical Hits Table (see p. 194). Additionally, for each 3 MoS, the player must make an additional roll on that table. Regardless of success or failure, the grabbing attack is finished at the end of the Physical Attack Phase; if the attacking player wishes to attempt to grab the turret once more, his 'Mech must make a new grabbing turret attack in the following turn.

If a 'Mech is in a hex with another unit that mounts a turret, or in a building hex that mounts a turret, all the same rules apply as above. A successful roll forces a Determining Critical Hit roll for the turret (i.e. in the case of a unit with it mounted in a location, the Determining Critical Hit roll is made for that location). As above, every 3 MoS forces an additional Determining Critical Hit roll.

### Grappling

This dangerous type of attack is an attempt to restrain an enemy unit through brute force. Only 'Mechs or ProtoMechs may attempt it, and only against other 'Mechs or ProtoMechs.

The grappling unit may not make any weapon attacks in the turn in which it attempts to grapple. The base to-hit number

of a grapple attack is equal to the attacking unit's Piloting Skill Rating (for ProtoMechs, use their Gunnery Skill Rating), with an additional modifier based on the relative weight classes of attacker and target. For every weight class by which the attacker is heavier than the target, apply a -1 to-hit modifier. For every weight class by which the attacker is lighter than the target, apply a +1 to-hit modifier. For example, an attempt by an assault 'Mech to grapple a medium 'Mech has a modifier of -2 because the attacker is two weight classes heavier than the target. In the case of ProtoMechs, treat them as a weight class underneath lights, so the assault 'Mech attempting to grapple a ProtoMech has a -4 modifier. In addition, the to-hit number may be modified for missing or damaged actuators in the same way as for a punch (see p. 145, *TW*). Damaged and missing actuators in both arms count toward this modifier because the grapple attack requires both arms, as well as leg actuator damage and gyro damage. All modifiers are cumulative.

If the attack is successful, the target is grappled. Move the attacking unit into the target's hex regardless of the standard stacking rules. In subsequent Physical Attack phases, the target can attempt to break the grapple by making an Attack Roll, applying the modifiers described above. For example, a medium 'Mech's attempt to break free of an assault 'Mech's grapple would have a +2 to-hit modifier because the medium 'Mech (now the attacker) is two weight classes lighter than its target (the assault 'Mech).

While grappling, neither unit may move or make physical attacks. The grappling 'Mechs may only fire head- and front torso-mounted weapons, and only at the grappling opponent. Such weapon attacks receive a -4 immobile-target modifier; however, neither grappling unit may make an aimed or called shot.

If other units attempt to attack the grappling units, they run the risk of hitting the friendly unit. Make the Attack Roll against the enemy unit first, with a +1 modifier. If the attack misses, make a second Attack Roll against the friendly unit, this time with no +1 modifier. If this attack succeeds, the player who made the rolls has hit the friendly unit by mistake.

If a unit breaks a grapple, move the unit that made the initial attack to any adjacent hex chosen by the player controlling the unit that broke the grapple. Place the attacking unit so that it faces the unit that broke the grapple. This move can result in the attacker being thrown off a high level or into water, or may result in other unit displacement. If either unit is destroyed, the grapple is broken and the surviving unit stays in the hex.

The attacking unit may choose to break the grapple in a subsequent Physical Attack Phase. Such an attempt counts as its physical attack for that phase. If the attacker breaks the grapple, the target immediately may make an Attack Roll in order to continue it; all grappling rules apply. If the roll is successful, the grapple continues with the target becoming the attacker. If this counterattack fails or if the original target does not wish to counterattack, the original attacker may move to any hex adjacent to the target, facing the target unit.

### Jump Jet Attack

As a desperate measure, a 'Mech can use the exhaust from its jump jets as an extremely short-range weapon. This type of attack, known colloquially as the "I Am Jade Falcon" maneuver, can only be used against targets adjacent to the attacker and so follows all standard rules for physical attacks.



Only 'Mechs with undamaged jump jets (but not mechanical jump boosters; see p. 292) in their legs can make a jump jet attack, and only if they are prone or at 1 level higher than the target. Also, the attacking 'Mech cannot have already jumped in the same turn.

If the attacking 'Mech is standing, it may only attack a target directly in front of and 1 level below it. It may only attack with the jump jets mounted in one leg, and may make no attacks with weapons mounted in that leg during that turn. Prone 'Mechs may only make jump jet attacks against a target in the hex directly behind them. The attacker may use jump jets mounted in either or both legs, provided that the legs used have not fired weapons in the same turn. The base-to-hit number for this type of attack is equal to the attacking unit's Piloting Skill Rating; all other appropriate modifiers apply, including the firing while prone modifier if the attacker is prone.

If the attack hits, it inflicts damage equal to the number of jump jets mounted in each attacking leg times 3. If both legs are used, determine hit location for each leg's jets separately. The damage from each leg's jets strikes a single location, determined on the appropriate column of the 'Mech or Vehicle Hit Location Table.

The attack generates heat as normal for the number of jump jets fired; this heat is also applied to the target unit for units that track heat.

### Tripping

This attack represents a leg hook or "clothesline" attack intended to knock the target off its feet. Only 'Mechs may make a tripping attack, and only against other BattleMechs.

The base-to-hit number for this attack is equal to the attacking unit's Piloting Skill Rating, applying a -1 to-hit modifier, in addition to all other standard modifiers. If the attack is successful, the target unit must make a successful Piloting Skill Roll at the end of the Physical Attack Phase or fall. Unlike a kick, a failed attack does not require the attacker to make a Piloting Skill Roll.

### CHARGING

In a standard charging attack, the attacker suffers relatively little damage compared to the target. The standard rules are structured this way to make possible such bold attacks as a *Hermes* charging an *Atlas*, which would otherwise be suicidal, as well as relatively easy to determine what that damage is. The following optional rule provides a more realistic way of determining damage between attacker and target, albeit at the expense of more complex math.

Follow standard rules for charging (see p. 148, *TW*), but change the damage to the attacker and target using the formulas found below. Round any fractions up after multiplication.

**Charging Terrain/Falling:** If players wish they can use these same formulas for determining "realistic" damage when charging/skidding into terrain or when falling.

$$\text{Target Damage} = \frac{[(\text{Attacker Mass} \times \text{Target Mass}) \times (\text{Hexes moved})]}{(\text{Attacker Mass} + \text{Target Mass})} / 10$$

$$\text{Attacker Damage} = \frac{[(\text{Attacker Mass} \times \text{Target Mass}) \times (\text{Hexes moved})]}{(\text{Attacker Mass} + \text{Target Mass})} / (10 + \text{MoS})$$

### DEATH FROM ABOVE

The best way to stop a death from above attack is to destroy the 'Mech as it jumps at the target. This optional rule allows the wreckage of the destroyed attacker to continue to hurtle toward the target and even cause damage.

If the attacking 'Mech is destroyed, its player should make a Piloting Skill Roll with an additional +1 modifier. If the roll is successful, resolve the attack as though the 'Mech had not been destroyed. The only change to the procedure is that the attack suffers an additional +1 modifier, and the damage is resolved differently.

If the attacker was destroyed by the loss of all its center torso internal structure, it hits the target in pieces. Divide the damage in half (round up), then into 5-point Damage Value groupings and apply it using the appropriate column of the Hit Location Table (not the Punch Hit Location Table). If the attacker was destroyed by any other means, it hits the target in one chunk. Divide the damage the attack would have inflicted in half (round up), but apply it all to a single hit location determined using the standard Hit Location Table. The target must make a Piloting Skill Roll or fall according to the standard rules.

The attacking 'Mech takes damage as though the attack had failed, which is only important for determining what is left of it for salvage after the battle.

### INTENTIONAL FALLS FROM ABOVE

Standard rules prohibit a unit from intentionally flinging itself off a hill to make an "accidental" fall from above attack against a target in a lower adjacent hex. In advanced-rules play, such an action is possible (if foolish).

Under advanced rules, a unit may deliberately walk or run off any level during the Movement Phase by spending 1 MP—if its pilot can muster up the guts to do so. To determine this, the controlling player makes a 2D6 roll, applying a -1 modifier to the Target Number for a Veteran pilot and a -2 modifier for an Elite pilot. If the result is greater than 9, the pilot is determined enough to make the leap. Otherwise, the unit's movement ends immediately.

If the unit manages to jump off the hill, move it into its new hex and resolve the fall immediately. The unit's movement ends at this point. If another unit is in the hex where the jumping unit falls, follow the rules for Accidental Falls from Above (see p. 152, *TW*). To reflect the intentional nature of the attack, apply an additional -1 modifier to the base-to-hit number.

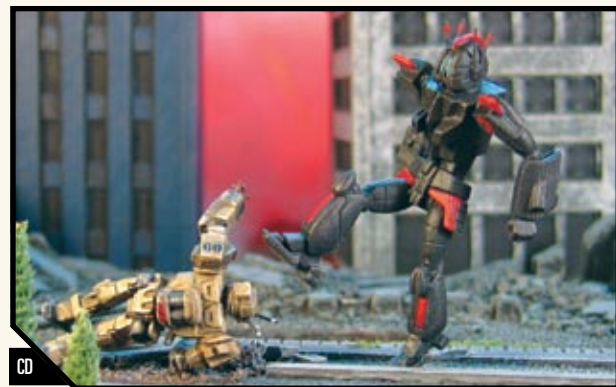

CD

*Under Condition Feral there can be no mercy from a Wolf's Dragoons warrior.*

INTRODUCTION

ADVANCED  
GROUND MOVEMENT

ADVANCED  
COMBAT

ADVANCED  
BUILDINGS

ADVANCED  
SUPPORT  
VEHICLES

GENERAL  
RULES

ADVANCED  
SUPPORT VEHICLE  
CONSTRUCTION

ADVANCED  
WEAPONS  
AND EQUIPMENT

INDEX

RECORD SHEETS



# PICKING UP AND THROWING OBJECTS

'Mechs with working hand actuators are capable of considerable dexterity. When combined with the strength of the 'Mech and its height, this allows them to pick up a variety of objects, carry those objects and potentially even throw objects a considerable distance.

The following rules build on the 'Mech Lifting Capabilities rules (see p. 261, *TW*); a 'Mech's lifting capability remains 10 percent of its tonnage; increased to 20 percent for operating Triple Strength Myomer (see p. 143, *TW*). However, that restriction is based on two working (unoccupied) hand actuators. A 'Mech can pick up 5 percent of its tonnage (increased to 10 percent for operating Triple Strength Myomer) with a single hand (arm).

**ProtoMechs:** These weight restrictions also apply to ProtoMechs, such that a one-handed, 2-ton ProtoMech can lift 100 kg (two-handed can lift 200 kg), while a one-handed, 9-ton ProtoMech can lift 450 kg (two-handed can lift 900 kg). Note that the construction rules for ProtoMechs automatically assume that it is built with two hands. The distinction here is for describing whether a player will designate that the ProtoMech is using one or two hands (i.e. one hand might already be carrying an object) for the various actions described in this section.

Additionally, anytime these rules call for a Piloting Skill Roll to be made by ProtoMechs, use the unit's Gunnery Skill Rating.

**Battle Armor:** Anytime the rules call for a Piloting Skill Roll to be made by battle armor, use the unit's Anti-'Mech Skill Rating.

**Four-Legged 'Mech:** Four-legged 'Mechs do not have hand actuators (obviously), and so cannot use any of these rules.

## Throwing Capabilities

Regardless of the object to be thrown (whether an inanimate object or another unit), a 'Mech with one working (unoccupied) hand actuator can throw objects up to 2.5 percent of its mass, while a 'Mech with two working (unoccupied) hand actuators can throw objects up to 10 percent of its mass. As usual, Triple Strength Myomer doubles the allowable weight.

Additionally, the distance any object or unit can be thrown is determined by the weight of the object/unit in comparison to the throwing unit's weight as shown on the Throwing Distance Table (round down). If the throwing unit has active Triple Strength Myomer, divide the weight of the thrown object/unit by 2 (rounding down) before consulting the Throwing Distance Table.

## THROWING DISTANCE TABLE

Percentage of Throwing 'Mech's Weight*	Total Distance
10%	1 Hex
7.5%	2 Hexes
5%	3 Hexes
2.5%	6 Hexes
1% (or less)	9 Hexes

\*If TSM is active, divide the weight of the thrown object/unit by 2 (rounding down) before consulting this table.

For example, a 100-ton 'Mech with a single hand actuator free could lift a 5-ton ProtoMech (as it is 5 percent of the 'Mech's weight), but could not throw the ProtoMech (as it can only throw 2.5 percent of its weight with a single hand). If the 'Mech had operational Triple Strength Myomer, however, which doubles its throwing capacity, it could not only lift the ProtoMech, but if the action was successful, the 'Mech could throw the ProtoMech up to a maximum distance of 3 hexes. If the 'Mech did not have active Triple Strength Myomer but was using two hand actuators (arms), the 'Mech could potentially throw the ProtoMech up to the 3-hex distance. Finally, if the 'Mech was using two hands (arms) and had active Triple Strength Myomer, the ProtoMech could be thrown up to a maximum of 6 hexes.

## PICKING UP INANIMATE OBJECTS

Any inanimate object may be picked up, provided it is within the weight limit for the 'Mech. However, as an inanimate object can literally be anything (a flag pole from a building, the roof of a house, a statue, an un-occupied car and so on), the players will need to agree on the weight of a given item before attempting to pick it up. Regardless, the unit must be in the hex with the object during the Physical Attack Phase; if the item is only "level 1" in height, the 'Mech must be in a hull-down position (see *Biped 'Mech* under *Hull Down* rules, p. 21) to pick it up.

Like finding a club, when attempting to pick up an inanimate object, the unit may not fire weapons or make physical attacks during the turn.

If the object is not attached to a fixed location, the player makes a standard Piloting Skill Roll. A failure means the object was not picked up; no damage is done to the object. A success means the object has been picked up.

If the object is attached to a fixed location (a building, the ground and so on), then divide the 'Mech's lifting ability by 4 to represent the strain of detaching the object. In addition, the 'Mech must make a successful standard punch attack to remove the object from its fixed location; if the weight of the object requires two hands to lift, then two successful punch attacks are required to pick up the object; the standard -4 immobile modifier is not applied when attempting to pick up an object. This means the controlling player announces that the 'Mech will attempt to pick up the object during the Movement Phase, but the physical attack to "tear off" the object does not occur until the Physical Attack Phase. A success (in the case of two arms, two successes) indicates the object has been picked up, while a failure (in the case of two arms, only a single failure need occur) means the object was not picked up.

Whether or not the object was successfully removed, it takes some type of damage. After every successful (or unsuccessful) attempt to remove an object from a fixed location, roll 1D6. On a result of 1-4, only minor damage occurs: the flagpole is bent, the statue goes from 1,000 kilograms to 900 kilograms and so on. On a result of 5, major damage occurs: half the flagpole snaps off, the statue goes from 1,000 kilograms to 500 kilograms, and so on. On a result of 6, the object is destroyed: the flagpole snaps into a handful of pieces, the statue shatters, and so on. Depending on the object, the players may need to come to a complete consensus about the specific damage done to a given object, using the rules above as a guideline.

**Physical Weapons:** As noted under *Dropping or Setting Down Inanimate Objects* (see p. 98), a hatchet, mace, sword or vibrosword can be dropped. Use the rules for picking such an item up exactly



as described above for an inanimate object; i.e. the 'Mech that originally dropped it or another 'Mech can attempt to pick it up, provided it can lift the weight. However, it cannot be used in a standard physical weapon attack; it can only be thrown as an inanimate object (see *Physical Weapons* under *Throwing Inanimate Objects*, p. 95). Only a 'Mech that was built to use that exact tonnage and critical space (or less) weapon and that does not currently hold another physical weapon can pick it up and then use the weapon as its own. For example a *Hatchetman* that does not currently hold a hatchet could pick up any of the four noted physical weapons, provided they weigh 3 tons and occupy 3 critical slots or less. For example the *Hatchetman* could obviously pick up another *Hatchetman's* hatchet, but it could not pick up an *Axman's* hatchet (it weighs 5 tons and occupies 5 criticals), yet it could pick up and use in a physical weapon attack the *Gurkha's* sword (it weighs 3 tons and is 2 criticals); or it could simply throw the sword as an inanimate object.

**'Mech Limbs:** Tearing off an object from a fixed location can include an arm or leg from a disabled and/or abandoned 'Mech (friendly or enemy); meaning the cockpit is destroyed, the MechWarrior is dead and/or ejected and so on. This also includes a shut-down 'Mech or one whose pilot is unconscious, making the 'Mech immobile. Regardless, the 'Mech must be prone and the 'Mech making the attempt to tear off a limb must end the turn in the target hex but with enough MP remaining to exit the hex. To avoid violating stacking rules, after the attack on the limb is made (whether successful or not), at the end of the Physical Attack Phase the 'Mech "spends" those held MP and enters the adjacent hex it was going to enter.

Note that like charging and DFA attacks, the unit doesn't finish its move until after the Movement Phase and so cannot be the target of a charge attack or DFA. However, the unit does occupy the hex. As such, any other type of physical attacks can be made against the unit during the Physical Attack Phase both before and after it spends its final MPs, it can be hit by a skidding unit, it can be the subject of displacement, and so on. If a Piloting Skill Roll is required to avoid falling and the 'Mech falls, it is automatically displaced into a random, legal adjacent hex. If the unit is displaced out of the target hex for any reason, such as for a fall, before it can tear off the arm, then the action automatically fails and the extra MP are lost as well; i.e. the unit's move is completely over.

The weight of the limb must be taken into consideration when attempting to lift it. A 'Mech limb is considered to weigh 10 percent of the 'Mech's total internal structure weight (regardless of damage taken to the internal structure), plus the weight of the armor (if any), rounded up to the nearest .5. In the case of advanced armors that provide extra points, that multiplier must be removed from the armor points to determine the actual weight of the armor on a limb. Finally, any equipment mounted in the arm must also be taken into consideration, such as heat sinks, weapons and so on; if a weapon is split across a limb and torso location the full weight of the weapon must be taken into consideration when determining if the attacking unit can lift the limb.

All the standard rules from above are used, except an additional +3 modifier is applied to the target number (applied to both punch attacks if two are required), to reflect the added strain required to tear a still-attached limb off the abandoned/immobile 'Mech; the modifier for a prone and adjacent target is never applied to this punch attack.

If the attack is successful, the shoulder/hip actuator is automatically destroyed; if a weapon is split across a limb and torso location, all critical slots in the torso are automatically marked off (in the case of exploding weapons, apply damage to the immobile 'Mech as per a standard critical to such a weapon; the weapon does not explode in the arm). Roll for determining critical hits and apply the damage to the other arm; if "limb blown off" is the result, the limb is destroyed and completely worthless. Finally, if the arm is not destroyed, roll 1D6 and apply that damage to the arm; if this results in internal structure damage, roll as normal for determining critical hits.

If any critical results in an ammunition explosion in the arm, subtract all the damage from the internal structure and the armor (the arm is completely destroyed, in this case), then apply any remaining damage in 5-point Damage Value groupings to random locations of the 'Mech holding the limb using the front column of the hit location table.

If the attack is unsuccessful, roll 1D6 and apply that damage to the arm; if damage is applied to internal structure, roll as normal for determining critical hits. Even if the internal structure is not damaged, roll for determining critical hits, but apply a -3 modifier to the die roll result.

*Loren wants his Caesar (with a Piloting Skill Rating of 4) to tear the arm off a BattleMaster that just had its cockpit destroyed in a previous turn. During the Movement Phase, he runs to enter the target hex where the prone enemy 'Mech is located, but he makes sure to hold the 2 MP required to enter the Clear Level 0 hex from the adjacent Level 1 hex where the prone 'Mech is located, as he can't violate the stacking rules at the end of the turn.*

*First, he has to determine the weight of the limb to make sure he can remove it. The weight of an un-damaged BLR-4S BattleMaster arm is 2.5 tons [8.5 (total internal structure weight) x .1 = .85 + 1.43 (26 (arm armor) / .9 (to remove the ferro-fibrous 1.12 multiplier)) = 23 / 16 (standard armor per ton) = 1.43] = 2.28, rounding to 2.5). However, the weight of the equipment in the arm must also be taken into consideration. The right arm mounts a 15 ton Gauss Rifle, making the total weight 17.5, while the right arm mounts 2 small pulse lasers, making the total weight 4.5. The Caesar is a 70-ton 'Mech and so can pick up 7 tons with two hands, or 3.5 tons with one hand. The Caesar cannot lift the weight of the right arm, but it can lift the weight of the left arm. Luckily Loren didn't fire the weapons mounted in either arm (and both hand actuators remain active), as he'll need both to lift the left arm.*

*Loren determines that his modified Target Number for the two punch attacks are 9 [4 (Piloting Skill Rating) + 0 (punch attack modifier) + 2 (attacker movement modifier) + 3 (modifier for tearing off a limb) = 9]. Loren rolls twice for a result of 10 and 11! He's torn off the limb; the controlling player crosses the limb off the BattleMaster.*

*Because the attacks were successful, Loren makes a note that the shoulder actuator is automatically destroyed. He also rolls once on the Determining Critical Hits Table, with a result of 8. Unfortunately, he has to assign another critical hit. He rolls to determine the location and comes up with a hand actuator. Loren rolls 1D6 with a result of 5 and marks off that much armor.*

*Finally, at the end of the Physical Attack Phase, he spends the held 2 MP to move into the adjacent hex.*

INTRODUCTION

ADVANCED  
GROUND MOVEMENT

ADVANCED  
COMBAT

ADVANCED  
BUILDINGS

ADVANCED  
SUPPORT  
VEHICLES

GENERAL  
RULES

ADVANCED  
SUPPORT VEHICLE  
CONSTRUCTION

ADVANCED  
WEAPONS  
AND EQUIPMENT

INDEX

RECORD SHEETS



### Carrying Inanimate Objects/Units

A 'Mech/ProtoMech may choose to carry the object (or unit; see the various following rules for picking up units) it has picked up. As noted previously, all the 'Mech Lifting Capabilities rules (see p. 261, *TW*) apply. However, if a 'Mech can pick up an object one-handed and does so, then it can fire weapons and make punch attacks from the arm that is not holding the object; all other restrictions still apply, including not firing any forward-firing torso-mounted weapons.

If the carrying 'Mech falls for any reason, it drops the object. Roll 1D6 and use the rules for picking up an object from a fixed location to determine damage. Depending on the type of object being used, players may wish to tweak these rules. For example, a large closet safe is likely not going to be destroyed by a drop, so a result of 1–5 may indicate minor damage, with 6 indicating major damage and no chance of destruction, while a box full of ancient pottery might receive major damage on a result of 1–2, while a 3–6 result will destroy the object.

**Carrying Hostile Units:** A carried hostile unit (again, see various following rules for picking up a hostile unit) has a facing equal to the facing when it was picked up (except 'Mechs, which always face the carrying 'Mech). If the carrying or carried units have torso weapons (or, in the case of a vehicle, weapons mounted in the location facing the carrying unit and/or a turret), they may fire at each other using the grappling rules (see p. 90). No attack may be made by either unit against any other units while a unit is being carried. Carried hostile battle armor may never be the target of a weapon attack.

During any Weapon Attack Phase that the carrying unit takes damage from the carried unit, the controlling player of the carrying unit must make an immediate Piloting Skill Roll with a +1 modifier; a failure means the carried unit was dropped (for a carrying 'Mech, a failed Piloting Skill Roll does not result in a fall). Units dropped this way resolve the fall as for an opposed Piloting Skill Roll MoS of 1–3 in favor of the carried unit as described below, but do not roll for any potential critical hits against the carrying unit.

Additionally, an opposed Piloting Skill Roll must be made at the start of each Physical/Driving Attack Phase (for vehicles, assign a –2 modifier to the die roll result to represent their less dexterous ability to break a hold). If the carrying unit has a greater MoS, it retains its hold on the carried unit. If the carried unit has a greater MoS, it breaks free.

An MoS of 1–3 in favor of the carried unit results in an immediate 2-level fall (1-hex fall if carried by a ProtoMech) for the carried unit. For 'Mechs, determine facing after the fall as normal; for vehicles, use the VTOL Rotor Destruction rules (see p. 197, *TW*); for battle armor, use the Infantry Falling Damage Table (see p. 151, *TW*); treat ProtoMechs as 'Mechs (see *Special Circumstances*, p. 185, *TW*). A dropped unit is placed either in the same hex as the carrying unit, or in a randomly determined adjacent hex if same-hex placement would violate the stacking rules, with a randomly determined facing. This may result in a fall greater than 2 levels, a domino effect and further displacement, all of which should be resolved immediately. If a unit cannot be appropriately placed (for example, if all the adjacent hexes are more than two levels higher than the hex of the carrying unit), then the dropped unit is destroyed.

Additionally, the controlling player of the carrying unit makes a Determining Critical Hit Roll to see if any critical hits occurred to the arm of the carrying unit. If critical hits occur and two arms

were used, randomly determine which arm all the critical hits are assigned to; note that in this instance, a dice roll result of 12 does not blow off the limb, but instead means that 3 critical hits are assigned (as normal, any “extra” critical hits that cannot be assigned are ignored). For ProtoMechs, if a critical hit occurs—regardless of how many—assign only a single critical hit (determined randomly if two arms were used) to the left-most open critical box on the affected arm.

An MoS of 4 or more in favor of the carried unit means it successfully drops to the ground without being damaged, while the carrying unit still determines if any critical damage occurred as described above.

If both units fail the Piloting Skill Roll, nothing happens. However, if both units fail their Piloting Skill Rolls and the carrying unit rolls a 2, then the carrying unit takes an automatic shoulder actuator critical hit (randomly determine an arm if both arms were used; for ProtoMechs, automatically mark off the right-most critical box) and the controlling player also rolls for potential additional critical hits as described above. The carried unit suffers a fall exactly as determined above, except it takes double the damage.

As noted for an object, if the carrying 'Mech falls for any reason, the carried unit is dropped; resolve as for an opposed Piloting Skill Roll MoS of 1–3 in favor of the carried unit as described above, but do not roll for potential critical hits against the carrying unit.

### Throwing Inanimate Objects

An object that has been picked up can be thrown either at a target hex or at another unit. A 'Mech must be standing to throw an object.

**Throwing at a Hex:** To throw an object at a hex, the controlling player makes a standard punch attack. Apply a +1 to-hit modifier for every hex beyond the first adjacent hex to the target hex; for example, throwing an object 6 hexes would apply a +5 modifier. However, the standard –4 to-hit modifier for an immobile target is still applied.

If the attack is successful, charging damage divided by 2 (see p. 148, *TW*) is applied to the target hex (whether a building, or terrain if using the Terrain Factor Rules on p. 64, and so on). In other words, the weight of the object is divided by 10, multiplied by the number of hexes thrown, divided by 2 and then rounded up, to a minimum of 1 point of damage.

If an object weighs 1 to 9 tons, inflict the base damage of 2 points for 1 to 3 tons, 3 points for 4 to 6 tons and 4 points for 7 to 9 tons; per normal charging damage, this is multiplied by the distance thrown and then divided by 2.

If an object weighs less than a ton, divide its kilograms by 1000, then multiply by hexes thrown and divide by 2, rounding up. If this number is less than 1, no damage is applied to the target. For example, a 650-kilogram statue is thrown 5 hexes, which would cause 2 points of damage [650 kilograms (weight of statue) / 1000 = .65 × 5 = 3.25 / 2 = 1.625, rounded up to 2].

If the level of the unit throwing the object is greater than the level of the target hex, then that must also be taken into consideration. In addition determine the potential damage for this “distance fallen” separately from the “distance thrown.” In other words, the weight of the object is divided by 10, multiplied by the number of levels fallen (adding +2 for a 'Mech, or plus 1 for a ProtoMech), rounded up, to a minimum of 1 point of damage (note that unlike distance thrown, this value is not divided). Once a player has determined both the distance thrown value and the



distance fallen value, only apply the greater value to both the target and thrown object.

If the attack is a failure, use the Altitude Bombing Scatter Diagram (see p. 245, *TW*) to determine where the object landed. Roll 1D6 to determine direction and then another 1D6 to determine distance (to the maximum hex range allowed for the object as shown on the Throwing Distance Table, p. 92).

Additionally, on a natural result of 2, the carrying unit takes an automatic shoulder actuator critical hit (randomly determine an arm if both arms were used; for ProtoMechs, automatically mark off the right-most critical box).

Regardless of whether the attack was successful, damage to the inanimate object is resolved with a 1D6 roll using the rules for picking up an object from a fixed location, but apply a +3 modifier to the die roll result.

**Throwing at Another Unit:** Use all the rules above for throwing at a hex, including the modifiers added for the number of hexes thrown, except instead of a punch attack the throwing unit makes a charging attack (per standard rules, the relative Piloting Skill Rolls of the attacking and target unit are taken into consideration).

If the attack is successful, apply the damage as noted above to the target, using the direction of the attack to determine the appropriate location. For battle armor, the damage only applies to a single trooper; for conventional infantry, the attack is treated as though it originated from another infantry unit.

If the attack is a failure, determine where it lands as described above; regardless of whether a unit is in the new hex, the attack fails to strike that unit (it automatically strikes any other non-unit object, such as terrain or a building).

**Physical Weapons:** The following Physical Attack Weapons can be thrown as inanimate objects (whether by the unit they are mounted on, or by another unit if the unit picks the object up (see *Physical Weapons* under *Picking Up Inanimate Objects*, p. 92): Hatchet, Mace, Sword, and Vibrosword.



MR

A pirate seeks to terrify his opponents with a make-shift flail using a 'Mech's head.

Use all the rules described above, with the following exception. If a unit is built to use the physical attack weapon (i.e. it can use the weapon in a physical weapon attack), apply a -1 modifier to the punch attack. When rolling to determine damage to the physical weapon, roll 1D6: on a result of 1-4, nothing happens, on a result of 5-6, the weapon takes a critical hit, applied to the topmost open critical slot. If the weapon is damaged, it can still be thrown as an inanimate object until all its critical slots are destroyed, but it cannot be used to make a physical weapon attack as soon as 1 critical slot is assigned.

## THROWING 'MECHS AND PROTOMECHS

To throw another 'Mech or ProtoMech, all the standard rules for carrying and throwing an inanimate object apply, except as noted below.

The 'Mech must have first grappled the target unit successfully (see *Grappling*, p. 90). During the following turn's Physical Attack Phase, provided the grapple has not been broken, the 'Mech may attempt to throw the grappled unit.

Both players make a Piloting Skill Roll, applying the appropriate modifiers from the 'Mech Throwing Tables to the die roll results. Compare Margins of Success. If the throwing 'Mech has a greater MoS, the throw is successful; use the difference in MoS to determine total distance thrown (to a maximum number of hexes as shown on the Throwing Distance Table, p. 92).

If the controlling player of the throwing 'Mech was attempting to hit a specific target (this target must be announced prior to making the first opposed Piloting Skill Roll), a second attack must immediately be made, using the rules for throwing at a hex or throwing at a target, as described for inanimate objects. If this second attack is successful, the thrown unit strikes the target. If the target was another unit, apply damage to the target and the thrown unit as described under throwing inanimate objects; resolve any displacements (and possible domino effects) if the stacking rules are violated.

A successful second attack against a target, even after a successful opposed Piloting Skill Roll for throwing a unit, can still miss the target if the MoS was not high enough to allow a sufficient number of hexes to be covered. In this case, place the thrown unit in the maximum hex range according to the MoS, along the LOS between the attacker and target.

If this second attack is not a success, or if the player did not nominate a specific target, use the Altitude Bombing Scatter

INTRODUCTION

ADVANCED  
GROUND MOVEMENT

ADVANCED  
COMBAT

ADVANCED  
BUILDINGS

ADVANCED  
SUPPORT  
VEHICLES

GENERAL  
RULES

ADVANCED  
SUPPORT VEHICLE  
CONSTRUCTION

ADVANCED  
WEAPONS  
AND EQUIPMENT

INDEX

RECORD SHEETS

## 'MECH THROWING TABLES

Unit Picking Up Is A:	Modifier
ProtoMech	+0
Light 'Mech	+0
Medium 'Mech:	+1
Heavy 'Mech	+2
Assault 'Mech:	+3

Unit Being Picked Up Is A:	Modifier
ProtoMech	+2
'Mech	+0



Diagram (see p. 245, *TW*) to determine where the object landed. Roll 1D6 to determine direction and then another 1D6 to determine distance (to the maximum hex range as determined by the MoS and allowed for as shown on the Throwing Distance Table, p. 92).

Note that unlike a thrown object, a thrown unit can potentially strike another unit located in the hex into which it is thrown. If the stacking rules for a given hex are not violated when the unit enters it, there is no chance for the thrown unit to strike another unit. If the stacking rules will be violated, however, roll 1D6; on a result of 4 or higher, a randomly determined unit in the target hex has been struck. Apply damage as described above; on a result of 1–3, no target is struck. In either case, resolve any displacements (and possible domino effects) appropriately.

Damage to the thrown unit and any target is resolved exactly like a thrown inanimate object, except the players randomly determine the direction of attack and apply the damage in 5-point Damage Value groupings to randomly determined locations on the thrown unit. Additionally, once that damage is resolved, the unit automatically takes additional damage as for a fall (unless “falling damage” was applied in place of “throwing damage”, in which case this additional damage is ignored); damage is applied to the unit as for an opposed Piloting Skill Roll with a MoS of 1–3 in favor of the carried unit, as described under *Carrying Hostile Units* (see p. 94). This damage is applied before any other damage if it occurs due to additional displacement and so on. If a thrown unit lands in a hex with a lower level, those additional levels should be taken into consideration when determining damage from the fall.

If the grappled ‘Mech or ProtoMech has the higher MoS, then the throw is unsuccessful. In the case of an MoS of 1 or 2, the grapple remains in effect. An MoS of more than 2 in favor of the grappled unit will result in the grapple being broken and the opposing unit being placed in an adjacent hex per the grappling rules (see p. 90).

If both units fail their Piloting Skill Roll, nothing happens; the grappled unit remains grappled.

If both units fail their Piloting Skill Rolls and the grappling unit rolls a 2, the grappled unit is dropped. Damage is applied to the unit as for an opposed Piloting Skill Roll with a MoS of 1–3 in favor of the carried unit (as described under *Carrying Hostile Units*; see p. 94), and the unit is placed in an adjacent hex per the grappling rules. Additionally, the grappling unit takes an automatic shoulder actuator critical hit (randomly determine which arm; for ProtoMechs, automatically mark off the right-most critical box).

### Attacks Against Units Carrying ‘Mechs/ProtoMechs

Use the rules for attacks against grappling units (see p. 90) to determine the results of an attack against a unit carrying another unit.

*Peter’s BRZ-C3 Berserker, with a Piloting Skill Rating of 4 and activated TSM, has managed to grapple a 20-ton Stinger with a Piloting Skill Rating of 2. At the start of the Physical Attack Phase of the following turn an immediate opposed Piloting Skill Roll is made to see if the Stinger breaks free. Peter rolls a 9, while his opponent rolls a 6; even with the +2 modifier for the differences in Piloting Skill Rating, Peter’s result is still higher, so the Stinger doesn’t manage to break free.*

*When it is Peter’s turn to nominate the Berserker for a physical attack he decides to try and throw the Stinger; with his activated TSM the ‘Mech is able to lift the 20 tons. He actually doesn’t care where he throws it, as all three hex facings from where his Berserker is standing (noting the Altitude Bombing*

*Scatter Diagram from p. 245 of TW) are off a cliff edge. Both players make Piloting Skill Rolls, applying the modifiers from the ‘Mech Throwing Table (which means Peter will add a +3 for his assault ‘Mech) as well as the differences of Piloting Skill Ratings. He rolls 2D6 with a result of 5 (which equals 8, with the +3 modifier), while his opponent rolls only a 4 (which equals a 6 with the difference in Piloting Skill Ratings). That provides a MoS of 2 so he successfully throws the Stinger!*

*Peter immediately rolls 1D6 with a result of 5 and consults the Altitude Bombing Scatter Diagram to determine the direction of the throw. While the MoS of 2 normally would mean that the Stinger would be thrown 2 hexes, consulting the Throwing Distance Table lets Peter know he can only throw the Stinger a maximum of 1 hex. Which is fine, since the Level 6 of the hex they occupy and the Level 0 of the target hex means damage will be determined as for an 8 level fall (the 6 levels of the difference between the two hexes, plus 2 for being thrown by a ‘Mech); since this will by far be greater damage than the “1 hex throwing charge,” the falling damage is applied to the Stinger. (If Peter and his opponent were using the Terrain Factor rules, that damage would also be applied in the terrain in the target hex.)*

### PICKING UP AND THROWING VEHICLES

To pick up vehicles, all the standard rules for picking up and carrying an inanimate object apply, except as noted below. Note that regardless of whether a vehicle is thrown or dropped, for simplicity it is always considered to land right side up.

**VTOL Vehicles:** If a VTOL Vehicle is successfully picked up, its rotor is automatically destroyed.

**Airborne Vehicles:** Airborne vehicles cannot be picked up; the vehicle must be landed.

**Fighters:** Fighters must be landed to be picked up, but are treated exactly like vehicles.

### Picking Up a Friendly Vehicle

To pick up a friendly vehicle, the ‘Mech must be in a hull-down position (see *Biped ‘Mech* under *Hull Down* rules, p. 21) and in the same hex as the vehicle during the Physical Attack Phase, and it cannot have made any weapon or physical attacks with either arm that turn.

The player makes a standard Piloting Skill Roll. A success means the vehicle is picked up, while a failure means it is not picked up; no damage or any other effects are applied. Apply a +1 modifier to the Piloting Skill Roll to stand if carrying a vehicle.

### Picking Up an Enemy Vehicle

To pick up an enemy vehicle, the ‘Mech must be in a hull-down position (see *Biped ‘Mech* under *Hull Down* rules, p. 21) and in the same hex as the vehicle during the Physical Attack Phase, and it cannot have made any weapon or physical attacks with either arm that turn.

The player makes a standard punch attack (two punch attacks if both hands are needed to lift the vehicle). If the attack(s) is successful, both units must make Piloting Skill Rolls as for the Throwing ‘Mechs and ProtoMechs rules (see p. 95). An MoS in favor of the carrying unit allows it to lift the vehicle up (in place of damaging the unit with the punch attack), while an MoS in favor of the vehicle allows it to avoid the attempt, taking half the standard punching damage instead.



If both units fail their Piloting Skill Rolls and either unit rolls a natural 2, then the 'Mech takes an automatic hand actuator critical hit (randomly determine which arm if two punches were made) and double damage for the punch.

Once the ground unit is held by the 'Mech, the 'Mech must stand (with a +1 modifier to the Piloting Skill Roll) in order to take any action other than holding the vehicle in place like a grapple (see p. 90).

### Throwing a Vehicle

Use the rules for throwing an inanimate object to throw a vehicle (see p. 94).

Damage to the thrown unit and any target is resolved exactly like a thrown inanimate object, except randomly determine the direction of attack and apply the damage in 5-point Damage Value groupings to randomly determined locations on the thrown unit. Additionally, once that damage is resolved, the unit automatically takes additional damage as for a fall; this damage is applied to the unit as for an opposed Piloting Skill Roll with an MoS of 1–3 in favor of the carried unit (as described under Carrying Hostile Units; see p. 94). This damage is applied before any other damage that may occur due to additional displacement and so on. If a unit is thrown and lands in a hex with a lower level, those additional levels should be taken into consideration when determining damage from the fall.

### Attacks Against Units Carrying Vehicles

Use the rules for attacks against grappling units (see p. 90) to determine the results of an attack against a unit carrying a vehicle.

### PICKING UP AND THROWING BATTLE ARMOR

To pick up and throw battle armor, all the standard rules for picking up and throwing an inanimate object apply, except as noted below.

#### Picking Up Friendly Battle Armor

A 'Mech may pick up a friendly battle armor squad if the 'Mech is equipped with two working (unoccupied) hand actuators. The total number of battle armor that may be picked up and carried in this manner is determined by the size of the 'Mech as shown on the Maximum Additional Battle Armor Table. Additionally, the weight of the battle armor being picked up must be taken into consideration as shown on the Advanced Battle Armor Weights Table (see p. 187); as normal, a 'Mech can only lift 10 percent of its weight.

Note that picking up friendly battle armor is in addition to any mechanized battle armor that might be carried by the 'Mech.

## MAXIMUM ADDITIONAL BATTLE ARMOR TABLE

'Mech Weight Class	Total Number of Battle Armor
Light	2
Medium	3
Heavy	4
Assault	6

Regardless of the total tonnage of the battle armor squad, a 'Mech can never pick up more than 6 troopers. Additionally, a 'Mech may only pick up a complete squad of battle armor. If there are more troopers in the squad than the 'Mech can carry, it may not pick up the squad. For example, a 50-ton *Hunchback* wants to pick up and carry a squad of Grenadiers. There are four active troopers, however, so it cannot pick the squad up. Its companion, a 70-ton *Archer*, may pick up the squad.

To pick up a friendly battle armor squad, the 'Mech must be in a hull-down position (see *Biped 'Mech* under *Hull Down* rules, p. 21) and in the same hex as the battle armor unit during the Physical Attack Phase, and cannot have made any weapon or physical attacks with either arm that turn. The player makes a standard Piloting Skill Roll. A success means the battle armor is picked up, while a failure means the troopers are not picked up; no damage or any other effects for a failed Piloting Skill Roll are applied. If the 'Mech is carrying the maximum number of battle armor for its weight class, assign a +1 modifier to the Piloting Skill Roll to stand.

*A Titan II is trying to decide between two hexes to go hull-down—one containing a friendly battle armor squad composed of 6 Nephilim or another containing a friendly squad composed of 6 Tengu. As an assault 'Mech, the 100-ton Titan II can pick up all 6 troopers. However, looking at the Advanced Battle Armor Weights Table, that equals 12 tons for the assault Nephilim and so the Titan II would not be able to pick the squad up (as it can only lift 10 percent of its weight with both hands; if it mounted activated Triple Strength Myomer, it could pick the squad up). Looking at the table again, the total trooper weight for the heavy Tengu battle armor is 9 tons, and so the Titan II's controlling player moves the 'Mech into that hex so he can go hull-down and make a standard Piloting Skill Roll to pick up the squad of 6 Tengu.*

#### Picking Up Enemy Battle Armor

Enemy battle armor follow all the same rules for picking up friendly battle armor, except that the rules for picking up a vehicle also apply. However, a 'Mech may only ever pick up two troopers, one in each hand.

In other words, the player makes a punching attack against the infantry unit. If successful, both players then make Piloting Skill Rolls. An MoS in the attacking unit's favor defines the trooper as "captured" in the 'Mech's hand (rather than damaging the trooper with the punch), while an MoS in the battle armor's favor means the trooper was not captured; instead, the trooper takes half the standard punching damage. In this instance, if two punch attacks are made, the opposing player makes a single Piloting Skill Roll for the battle armor unit, but the opposing player makes two separate Piloting Skill Rolls to compare for MoS (representing both arms).

If a trooper is grabbed in this fashion, it automatically becomes a squad of 1, with the controlling player tracking it as though it is a separate unit; the trooper is pulled from the squad to which it was attached. If two punch attacks are successful and two Piloting Skill Rolls win the MoS, then each trooper is its own unit, with the controlling player separating both units off from the original squad.

INTRODUCTION

ADVANCED  
GROUND MOVEMENT

ADVANCED  
COMBAT

ADVANCED  
BUILDINGS

ADVANCED  
SUPPORT  
VEHICLES

GENERAL  
RULES

ADVANCED  
SUPPORT VEHICLE  
CONSTRUCTION

ADVANCED  
WEAPONS  
AND EQUIPMENT

INDEX

RECORD SHEETS



If at any point later in the scenario those single trooper squads are in the same hex as the original squad they were attached to during the End Phase of turn, they may automatically rejoin their unit.

### Throwing Battle Armor

The rules for throwing an inanimate object apply to battle armor, except a 'Mech may only throw a maximum of two battle armor troopers, even if the 'Mech is attempting to throw both troopers at units and so can still make two "charging attacks" (one for each arm). If the 'Mech is carrying more than one battle-armored trooper in an arm, it may not throw that battle armor.

*Chris' Seraph Dominus, with a Piloting Skill Rating of 3 and activated Triple Strength Myomer, has walked and then gone hull down in a light woods hex with an elite enemy battle armor squad that jumped 3 hexes, composed of four Phalanx with an Anti-'Mech Skill of 2. Chris didn't make an attack with the Seraph's left arm at any prior point in the turn, and so he can make a punching attack against the Phalanx to attempt to grab a trooper.*

*To make the attack, the modified To-Hit Number is 8 [3 (Piloting Skill Rating) + 0 (punch attack modifier) + 1 (attacker movement modifier) + 2 (target movement modifier) + 1 (light woods) + 1 (battle armor modifier) = 8]. Chris rolls 2D6 and gets a result of 8: a successful punch. Instead of dealing damage, however, Chris wants to try to capture a trooper. He and his opponent each make Piloting Skill Rolls (an Anti-'Mech Skill Roll for the battle armor). Because the Anti-'Mech Skill Rating of the battle armor is 1 less than the 'Mech's Piloting Skill Rating, a +1 modifier is added to the die roll result for the opponent. Chris rolls 2D6 for a result of 9, while the opponent's roll result is a 7. Even with the +1 modifier, that still leaves an MoS of 1 for Chris... he's snagged the battle armor! The opponent immediately notes on the squad's record sheet that he now has two Phalanx battle armor squads, one of 3 troopers and one of 1 trooper.*

*Chris notes wryly that if the MoS had not been in his favor, he would've done 9 points of damage [85 (tonnage of the Seraph) / 10 = 8.5, rounding to 9, x 2 (activated TSM) / 2 (failed attempt to grab trooper) = 9]. As the Phalanx only has 8 total armor, including the trooper, that would have ended it real quick.*

*During the Movement Phase of the following turn, Chris successfully stands the Seraph up from its hull down position. At the start of the Physical Attack Phase of that same turn, an immediate opposed Piloting Skill Roll is made to see if the battle armor breaks free. Chris rolls a 10, while the opponent gets a 5 (making it a 6 with the +1 modifier for the difference in skill ratings). No luck, the trooper is still stuck.*

*During his turn to nominate the Seraph in the Physical Attack Phase, Chris verifies the weight of the Phalanx in comparison to the 'Mech. The 1.5 tons of the Phalanx is 1.76 percent of the Seraph's 85 tons [1.5 / 85 = .0176, or 1.76 percent]. Looking at the Throwing Distance Table, this weight is higher than 1 percent of the Seraph's weight, and so even with the TSM activated (which doesn't change the distance an object can be thrown, only the weight that can be picked up), he can only throw the battle armor 6 hexes. He sees an enemy 'Mech 6 hexes away, which has moved 4 hexes and has a Piloting Skill Rating of 4; there are 2 woods hexes intervening. This provides a final "charging attack" modified To-Hit Number of 11 [3 (Piloting Skill Rating)*

*+ 1 (attacker movement modifier) + 1 (target movement modifier) + 2 (two light woods hexes) + 5 (distance thrown beyond the adjacent first hex) - 1 (difference in Piloting Skill Rolls) = 11]. Chris makes the roll with a result of 12! A hit!*

*Next, Chris must figure out the damage to apply to attacker and target, and arrives at 6 points [2 (base damage for a 1-3 ton object) x 6 (number of hexes) = 12 / 2 = 6]. He randomly determines two hit locations, using the appropriate direction of attack, and applies a 5-point and a 1-point Damage Value grouping to the target 'Mech. Six points of damage is then applied to the Phalanx for the "charging attack". Next, damage for a 2-level fall is applied, which the players determine is 1 additional point after looking at the Infantry Falling Damage Table. Finally, the Phalanx (minus all its armor, but still alive), is placed in the hex where it landed.*

*If the opposing player manages to move the lone trooper into a hex with the original Phalanx squad during a future turn, the trooper can automatically re-merge with its unit during the End Phase.*

### Attacks Against Units Carrying Battle Armor

Attacks against a unit carrying battle armor in its hands may strike that battle armor as well. When a 'Mech takes a hit on either arm where it is carrying battle armor, roll 1D6. On a result of 1-4, the battle armor unit does not take damage, and the total value of the weapon damage is applied directly to the carrying unit's location; a result of 5-6 means the carried battle armor unit is hit.

For battle armor, a randomly chosen trooper takes maximum damage before the entire carrying unit takes damage. Any damage left after the trooper is destroyed is applied to the location hit.

### DROPPING OR SETTING DOWN INANIMATE OBJECTS

A unit may drop a carried object/unit at anytime. If an object is simply dropped, roll 1D6 and use the rules for picking up an object from a fixed location to determine damage; for a dropped unit, resolve damage as for an opposed Piloting Skill Roll with an MoS of 1-3 in favor of the carried unit, as described under *Carrying Hostile Units* (see p. 94).

To set down an object, a 'Mech must go hull-down (see *Biped 'Mech* under *Hull Down* rules, p. 94), an expense of 1MP. The object is placed in the carrying unit's hex or any adjacent hex to the arm arc (if both arms are carried, this must be the front arc), at the controlling player's discretion. A 'Mech can set the object down on an adjacent Level 1 or Level 2 without going hull-down, but must still expend the 1 MP. A ProtoMech can place an object in a hex at the same level as its underlying terrain or at Level 1, only paying the 1 MP cost.

**Physical Weapons:** During the End Phase of any turn a player with a 'Mech mounting a Hatchet, Mace, Sword or Vibrosword can declare he is dropping the weapon, regardless of whether the weapon is destroyed or not; i.e. the hand actuator in that arm is "occupied" by the weapon and so cannot be used unless the weapon is dropped. The player should simply note that the weapon in question is no longer on the 'Mech and is in the unit's hex (it is now an inanimate object), and also let players know whether the weapon is "destroyed" due to a critical slot hit, or all the critical slots remain undamaged. The same unit, or another unit, can then attempt to pick it up just like an inanimate object (see *Physical Weapons*, p. 92).



## DRAGGING A 'MECH

In place of picking up a 'Mech, two friendly 'Mechs may attempt to drag a disabled and/or abandoned 'Mech (friendly or enemy) from the playing area; a friendly immobile 'Mech can be dragged in this fashion, but an enemy immobile 'Mech cannot (it must be disabled and/or abandoned).

Each 'Mech must have two working hand actuators (unoccupied), and the 'Mech to be dragged must have at least 1 internal structure point in both arms or both legs. Both 'Mechs must be in a hull-down position (see *Biped 'Mech* under *Hull Down* rules, p. 21) in an adjacent hex, facing the downed 'Mech. When they stand back up, both apply a +1 modifier to their Piloting Skill Rolls. If either roll fails, nothing occurs, but they fail to "latch onto" the downed 'Mech. Both 'Mechs must go hull-down and attempt to stand back up with the downed 'Mech once again.

The weight of the 'Mech to be dragged must be equal to or less than the combined weight of the two 'Mechs doing the dragging. Additionally, use the Movement Penalties under *Cargo Carriers* (see p. 261, *TW*) for the modifications to movement for dragging; treat the dragged unit's weight as half (round down), applied to each dragging 'Mech. For example, a 5/8 *Quickdraw* and a 4/6 *Hunchback* are dragging a 25-ton *Cossack*. A quarter of 50 tons is 12.5. Half of the *Cossack*'s weight is also 12.5 (the weight applied to both the *Quickdraw* and *Hunchback*), so they either subtract 3 or cut in half, rounding down (which ever is less) their Walking MP. In this instance that leaves the *Hunchback* with a Walking MP of 1 and the *Quickdraw* with a Walking MP of 2; neither unit can move faster than the *Hunchback*'s Running MP of 2 while dragging the unit.

While the two 'Mechs are dragging the other 'Mech they are considered to be in the same hex with the prone 'Mech, both with the same facing, while the prone 'Mech is being dragged by its arms or legs (and so is facing in the same or opposite direction), face-down. No other units, infantry or otherwise, can occupy the hex. Neither dragging 'Mech can make any physical or weapon attacks. Any attacks against any of the three 'Mechs involved that miss the target automatically have a chance at striking the two dragging units (see the *Missed Shots* rule, p. 81).

If either dragging 'Mech falls (due to damage, terrain and so on), the falling 'Mech is displaced into a randomly determined adjacent hex (it is displaced before falling damage occurs), while the other 'Mech "loses its grip." Though it does not fall, it also is randomly displaced into an adjacent hex. In both cases, players should avoid additional displacements if possible; if they are unavoidable, resolve any additional displacements and/or domino effects as appropriate. A successful charging attack or a death-from-above attack against either dragging 'Mech automatically displaces all three 'Mechs; randomly determine which 'Mech to displace first, then displace the second 'Mech and finally the third 'Mech, resolving damage and any additional displacements that this might cause in order.

At the end of every Movement Phase after the dragging 'Mechs have moved into a new hex (regardless of how many hexes), each should make a Piloting Skill Roll. If either roll fails, the 'Mechs do not fall and do not lose their grip. Instead, a failure means they were unusually rough in pulling the prone

'Mech. If one or both dragging 'Mechs fail the Piloting Skill Roll, apply 1D6 points of armor as a single Damage Value grouping to a randomly determined location on the prone 'Mech, using the Front column of the hit location table. Additionally, roll for determining critical hits and apply any that occur to a random location using the Front column of the hit location table; if more than one critical hit is rolled, assign each critical hit to a different location (ignore a "limb blown off" result and apply 3 critical hits instead).

## OTHER COMBAT WEAPONS AND EQUIPMENT

The following section provides additional optional rules that enhance the capabilities of certain weapons and equipment.

### ACTIVE PROBES

Active probes are primarily used to locate hidden units on the battlefield—battle armor as well as 'Mechs and vehicles. Active probes cannot detect hidden unarmored infantry.

### Hidden Units (Expanded)

In standard-rules play, the player determines if any enemy units lie within the detection radius of an active probe after the unit has finished moving (see p. 129, *TW*). As an optional rule, the effect radius can be active throughout the unit's entire movement. This allows a probe-equipped unit to detect hidden units along its movement path, whereas the standard rules can result in a probe passing a hidden unit without detecting it.

### Targeting

Another optional rule allows active probes to aid in targeting enemy units within the probe's range. If the target is within the probe's range and line of sight exists to the target, reduce the total to-hit modifier for firing through and into woods/jungles by 1 (that is, reduce the total woods/jungles modifier by 1, regardless of the number of woods/jungle hexes involved).

### Concealing Information

A unit with an active probe can also acquire information about an enemy unit's status if players are playing with concealed record sheets (see *Concealing Information*, p. 219).

### Minefields

A unit with an active probe can potentially reveal minefields (see *Weapon-Delivered Minefields*, p. 210).

### ECM Suites

A unit with an active probe will find it easier to overcome an ECM's ghost target ability (see *Ghost Targets*, p. 101).

### ANTI-MISSILE SYSTEMS

To increase the effectiveness of anti-missile systems, the following two optional rules are available.

INTRODUCTION

ADVANCED  
GROUND MOVEMENT

ADVANCED  
COMBAT

ADVANCED  
BUILDINGS

ADVANCED  
SUPPORT  
VEHICLES

GENERAL  
RULES

ADVANCED  
SUPPORT VEHICLE  
CONSTRUCTION

ADVANCED  
WEAPONS  
AND EQUIPMENT

INDEX

RECORD SHEETS



### Enhanced Missile Defense

Under *Total Warfare* rules, an anti-missile system subtracts four from the die roll result on the Cluster Table for a missile weapon, but this cannot be modified below a result of 2. In this optional rule, anti-missile systems can be more effective. If the modified die roll result is less than 2, the anti-missile system has successfully destroyed all the missiles and no damage from the weapon is applied.

### Used As a Weapon

Though designed as a defensive measure, the standard anti-missile system is a kind of specialized machine gun and can be fired as an offensive weapon in a pinch. An AMS used as a weapon functions exactly like a machine gun, except that it has a range of 1; it cannot reach targets at medium or long range (or more). A laser AMS used as a weapon acts like a micro pulse laser with a maximum range of 1.

### AUTOCANNONS

Compared to laser weapons, autocannons have little to recommend them except for heat efficiency and submunitions. The following advanced rules suggest several options that make autocannons more potent weapons on the battlefield.

Note that these options only apply to autocannons, not other types of Direct-Fire Ballistic weapons such as Gauss rifles and artillery cannons.

#### Optional Firing Modes

Autocannons fire bursts of large-caliber shells to damage a target, much like enormous machine guns. They can be used in rapid-fire mode or fired at multiple targets, as described below.

**Rapid-Fire Mode:** Any standard or light autocannon (not LB-X, Ultra or Rotary models) can be fired at double the standard rate as though it were an Ultra AC. This approach carries considerable risks. Follow the standard rules for a Rapid-Fire Weapon firing two shots (see p. 114, *TW*), with the following exceptions.

The weapon's arming circuitry fails on a To-Hit Roll result of 4 or less (rather than 2 or less). On a To-Hit Roll result of 2, the ammo feed jams, causing the rounds in the chamber to explode inside the barrel. This causes an effect similar to an ammunition explosion, but inflicts only the amount of damage the autocannon would normally inflict in one shot and does not cause any other ammo to explode. The autocannon is considered completely destroyed (meaning players must mark off all of its critical slots). CASE keeps this damage from spreading to other locations, but the MechWarrior still receives two pilot hits.

Double the heat generated by the specific weapon type used when firing in Rapid-Fire Mode.

**Multiple Targets:** Rather than firing at a single target, any type of autocannon can be "walked" across two targets close to one another. An LB-X autocannon firing a cluster shot and Ultra and Rotary autocannons firing at multiple targets are a special case.

No matter what type of autocannon is being used, both targets must be in adjacent hexes and within range of the weapon. Determine the to-hit number for both targets and make separate to-hit rolls against each target, using the higher (more difficult) of the to-hit numbers and adding a +1 modifier for firing at multiple targets with a single shot. Note that this is not the secondary target modifier; that modifier does not apply to this type of attack unless multiple targets also are being attacked in the same phase. If the to-hit roll succeeds, the target is struck by a single hit that inflicts

damage equal to half the normal damage done by the weapon (rounded down).

For an LB-X autocannon firing a cluster shot, make a single to-hit roll against the highest to-hit number plus 1. If all damage is applied to the first target after a roll on the Cluster Hit Table, then no additional damage is applied to the second target. However, if some of the damage missed the target, use that "missed" Damage Value as the new number to roll on the Cluster Hit Table to determine what damage struck the second target. For example, a controlling player rolls a 7 on the Cluster Hit Table roll for an LB 10-X, resulting in six 1-point Damage Value groupings hitting the first target. That leaves 4 damage and so the controlling player would then roll on the 4 column of the Cluster Hit Table to see what damage is applied to the second target.

For Ultra and Rotary autocannons, make a single to-hit roll against the highest to-hit number plus 1. Then determine whether the designated number of shots fired hit a target. If only one shot hit, it will strike one of the targets—determined at random—with a single shot that does full damage. If two, four or six shots hit, one, two or three shots will strike each target at full damage. If three or five shots hit, one or two shots will strike each target; randomly determine where the other shot lands.

When using this attack from a non-infantry unit against conventional infantry, treat the weapon as the next row above on the Non-Infantry Weapon Damage Against Infantry Table (see p. 216, *TW*). i.e. a Cluster (Ballistic) becomes a Direct Fire (Ballistic) attack.

Players can fire at multiple targets in rapid-fire mode (see above). Resolve damage as though the autocannon is a Rapid-Fire weapon firing two shots.

### ECM SUITES

The rules below expand on the use of ECM suites.

#### ECCM

An ECM suite can be tuned to act as electronic counter-countermeasures (ECCM) in order to negate enemy ECM systems. The ECM loses its normal functions when used in this way. The player must announce the switch to ECCM in the End Phase of any turn, or may set the suite for ECCM at the start of the scenario. In either case, note the change on the record sheet of the unit in question.

While the ECCM suite is active, the electronic countermeasures of an enemy unit within the ECCM's radius will not work. Also, any LOS traced through a hex that is encompassed by both ECM and ECCM will be unaffected by the ECM, even if the actual unit carrying the ECM suite is outside the ECCM bubble.

If multiple units equipped with both ECM and ECCM are on the map, the interaction between the two types of electronics systems becomes complicated, because multiple ECM suites operating in the same area can counter an enemy's ECCM (see ECCM diagram, p. 101). One ECCM suite can counter one ECM suite.

If the amount of friendly ECCM in a hex is equal to or greater than the enemy ECM in that hex, ECM does not function in that hex. For this purpose, the Angel ECM suite (see p. 279) counts as two ECM or ECCM suites, or the player can choose to run the Angel at 1 ECM and 1 ECCM.

**Communications Equipment:** Communications equipment (see p. 212, *TechManual*) can be used to generate an ECCM field with the same area of effect as an Inner Sphere Guardian ECM Suite. Any unit that mounts 3 to 6 tons of communications equipment equals half of an ECM suite when generating an ECCM



field. If the unit mounts 7 or more tons of communications equipment, it equals 1 ECM suite when generating an ECCM field. Any time communications equipment is used to generate an ECCM field, all other bonus modifiers are lost.

### Ghost Targets

An ECM suite can be tuned to generate “ghost targets” that may affect the ability of enemy units to properly target friendly units. The ECM loses its normal functions when used in this way. The player must announce the switch to ghost target generation in the End Phase of any turn, or may set the suite for ghost target generation at the start of the scenario. In either case, note the change on the record sheet of the unit in question.

At the start of every Weapon Attack Phase when an ECM is tuned to generating ghost targets, the controlling player makes a Piloting Skill Roll with a +2 modifier; no other modifiers are applied to this roll. If the roll fails, he did not tune the

ECM correctly and no effects are applied for that turn. On a successful roll result, he attuned the ECM properly; the player should note the result’s Margin of Success.

During a turn’s Weapon Attack Phase, if a weapon attack passes through the ECM bubble of an enemy ECM unit tuned to generating ghost targets and the controlling player made a successful Piloting Skill Roll that turn, the attacking player must also make a Piloting Skill Roll before making a to-hit roll for the weapon attack in question; the only modifier added to this Piloting Skill Roll is the MoS of the enemy ECM unit. If the roll is a success, the to-hit roll is made as normal; the attacker’s targeting and tracking system is able to differentiate between all the ghost targets. If the roll fails, for every 2 MoF (round down), apply a +1 to-hit modifier to all weapon attacks that pass through the ECM bubble for that turn by that attacker. Note that an attacking player only makes a single roll, regardless of how many weapons are firing, applying any modifiers to all weapon attacks equally.



• ECM DIAGRAM •

INTRODUCTION

ADVANCED  
GROUND MOVEMENT

ADVANCED  
COMBAT

ADVANCED  
BUILDINGS

ADVANCED  
SUPPORT  
VEHICLES

GENERAL  
RULES

ADVANCED  
SUPPORT VEHICLE  
CONSTRUCTION

ADVANCED  
WEAPONS  
AND EQUIPMENT

INDEX

RECORD SHEETS



If an attack passes through multiple ghost target-generating ECM fields, only a single roll is made. Determine the highest Margin of Success from those multiple enemy ECM fields, applying an additional +1 for each additional field, and then applying the total modifier to the Piloting Skill Roll. A +4 to-hit modifier is the maximum that can be applied to a weapon attack through the use of ghost target ECM fields. For example, if an attack passed through three ghost target-generating ECM fields and the highest Margin of Success of those fields was a 3, the modifier applied to the Piloting Skill Roll would be 4 [+3 (highest MoS of the three ECM fields) +2 (2 additional ECM fields) = 5, but only a maximum +4 can be applied].

**Angel ECM Suite:** An Angel ECM Suite can be tuned to be 1 ECM or 1 ECCM while it generates ghost targets.

**Communications Equipment:** Communications equipment (see p. 212, *TechManual*) can be used to generate ghost targets with the same area of effect as an Inner Sphere Guardian ECM suite. However, to do so, the unit must mount 7 or more tons of communications equipment. Any time communications equipment is used to generate an ECCM field, all other bonus modifiers are lost.

**ECCM:** Just as standard ECM functions cease when inside an enemy ECCM field, an ECM cannot generate ghost targets if the amount of friendly ECCM in a hex is less than the enemy ECCM in that hex.

**Active Probe:** For any unit making an attack that also mounts an active probe, apply a +1 modifier to the die roll result when making the Piloting Skill Roll to determine the to-hit modifier as described above.

**Targeting Computers:** Any units making an attack with a weapon wedded to a targeting computer (see 143, *TW*) apply a +2 modifier to the die roll result when making the Piloting Skill Roll to determine the to-hit modifier as described above.

**Cockpit Command Console:** If a unit mounts a cockpit command console and has a second pilot that enables all its other abilities to function (see *Cockpit Command Console*, p. 300), it can be used to generate ghost targets with the same area of effect as an Inner Sphere Guardian ECM suite. Additionally, apply a +3 modifier to the die roll result when making the Piloting Skill Roll to determine the to-hit modifier for attacks from such a unit as described above.

## ENERGY WEAPONS

Any energy weapon (either Direct Fire or Pulse) can dial down its Damage Value, cutting back on heat generated. Before a controlling player makes a to-hit roll for an energy weapon attack, he can announce that he is "dialing back" the Damage Value. For each 1 point less of Damage Value, the weapon generates 1 less heat point than normal, to a minimum of 1 heat; regardless of whether a weapon's Damage Value is reduced to 0, the weapon will always generate at least 1 heat. For example, a medium laser could dial back its Damage Value of 5 down to a 3 to only generate 1 heat. However, even if the medium laser's Damage Value is dialed back to a 2, 1 or even 0, the weapon would still generate 1 heat. Meanwhile, an Inner Sphere ER large laser dialed back to a 0 Damage Value would still generate 4 heat.

This dialing back rule has no other affect; i.e. it doesn't change a weapon's range, to-hit modifiers, and so on.

**Ammo:** Any energy weapon that is ammo-dependent (such as a vehicle flamer, Plasma weapons and chemical lasers) cannot make use of this rule.

**Bombast Laser:** Only use this rule for a Bombast Laser when dealing with a Damage Value of 7 or less. For a Damage Value greater than 7, use that weapon's special rules (see p. 320).

## GAUSS WEAPONS

Though an extremely effective weapon, the Gauss rifle has one major drawback: it will explode if struck by enemy fire. Under the following optional rules, however, a Gauss rifle can be "powered down" to prevent an explosion.

During the End Phase of any turn, the controlling player may announce that he is powering down his weapon (or powering up a previously powered-down weapon). The change must be marked on the record sheet of the unit in question. A powered-down Gauss rifle may not fire but does not explode if it suffers a critical hit. The powered-down weapon will still be destroyed, however, if it takes a critical hit.

## MACHINE GUNS

The humblest weapon on the battlefield, the often-neglected machine gun can be fired in new optional modes in advanced-rules play. Like autocannons (see p. 100), machine guns can be fired against multiple targets or in rapid-fire mode.

Against multiple targets, machine guns use the rules for autocannons. If any of the targets is a conventional infantry unit, after determining the number of troopers eliminated (see Burst-Fire Weapon Damage Vs. Conventional Infantry Table, see p. 217, *TW*), divide the value in half (round down) to minimum of 1.

When rapid-firing, use the optional rule below.

### Rapid-Fire Mode

A machine gun may be modified to fire at a much higher rate than normal, chewing up huge amounts of ammunition but significantly increasing the weapon's damage potential. The controlling player must mark any machine guns to be used in rapid-fire mode on the record sheet at the beginning of the game, and the weapons must be rapid-fired for the entire game.

Each time the weapon is rapid-fired, roll 1D6 to determine the heat generated. This number also becomes the damage inflicted by the weapon if it hits (it is possible for a burst to inflict only 1 point of damage). Each rapid-fire burst uses a number of rounds equal to the damage it inflicted x 3.

Rapid-fire machine guns do not inflict increased damage on conventional infantry.

**Light and Heavy Machine Guns:** For light machine guns, the damage and heat is 1D6 -1 (to a minimum of 1); for heavy machine guns the damage and heat is 1D6 +1.

**Machine Gun Array:** Machine Guns cannot be fired in rapid-fire mode when fired as part of a Machine Gun Array (see p. 137, *TW*); for Machine Guns in an array to use rapid-fire mode, the Machine Gun Array must be shut off, or destroyed.

## MISSILES

The minimum range of LRMs and ATMs in the standard rules reflects the time it takes for the internal guidance systems to lock on to targets and for the explosive payloads to arm. Hot-loading enables a player to arm his LRM or ATM warheads before firing the missiles.

Because a 'Mech's ammo bays are enclosed during battle, LRMs and ATMs must be hot-loaded before a scenario.



The controlling player must indicate which ammo slots are “hot-loaded” on the ‘Mech’s record sheet before play begins. Because vehicles have crews that can set up LRMs or ATMs to be hot-loaded during battle, a player controlling a vehicle can announce hot-loading during the End Phase of a turn. After the End Phase of the following turn, any of the vehicle’s LRM or ATM launchers can be set to fire hot-loaded missiles. A player may follow the same procedure to switch back to normal firing mode.

Minimum-range modifiers do not apply to hot-loaded LRMs and ATMs. However, hot-loaded LRMs and ATMs are not as accurate as standard missiles. When resolving damage from a flight of hot-loaded LRMs or ATMs, the attacking player rolls 3D6. Add the two lowest die results together to determine hits on the Cluster Hits Table.

Because hot-loaded LRMs and ATMs are fully armed in the launcher, any critical hit to the launcher triggers a missile explosion that destroys all of the launcher’s critical slots. Also, the body location of the launcher takes damage equal to the maximum potential damage of the missile flight. For example, an exploding hot-loaded LRM 10 launcher causes 10 damage points to the internal structure of the location where it’s mounted. Any time a hot-loaded missile launcher explodes, the controlling player must roll 2D6. On a result of 2 through 5, the destruction of the launcher triggers an ammunition explosion in a single ammunition slot in that location (randomly determined), if any exist in that location. Note that vehicles store their ammunition in the “body” away from where the actual launchers are mounted and so this roll is never made for a vehicle.

**Equipment:** All missile-related equipment still apply all their standard modifiers when using this rule, such as Artemis-IV, -V, NARC and TAG munitions and so on. Smoke and illumination rounds are also un-affected by hot-loading missiles.

**Mine Clearing:** Mine-clearing attacks are unaffected by this distinction.

**Vehicle Crews:** If a vehicle has a crew of 1, it cannot make use of hot-loaded LRMs unless they are designated as such before the start of the game.

## PARTICLE PROJECTOR CANNON (PPC)

The following provide optional rules for PPC use.

### Disengaging Inhibitor

Advanced rules for particle projector cannons allow players to disengage the weapon’s field inhibitors if they so desire. The field inhibitors restrict the dangerous charged-particle feedback produced when a PPC is fired, but also prevent the weapon from firing accurately at targets closer than minimum range. Disengaging a PPC’s field inhibitor removes the mini-

imum range modifier, at the risk of subjecting the firing unit to particle feedback.

To disengage a unit’s PPC inhibitor, a player must declare the inhibitor disengaged during the End Phase of a turn; the inhibitor will stay disengaged until a player announces during a subsequent End Phase that it is re-engaged. The standard minimum-range modifier does not apply to that attack; otherwise, the player makes his to-hit roll per standard rules. The player must then roll 2D6 and compare it to the PPC Feedback Table, below, to determine if the shot causes particle feedback. If the result is less than the safe level shown above, the first unmarked PPC critical slot is destroyed and the ‘Mech takes additional damage equal to the Damage Value of the PPC (as well as capacitor, if the PPC is connected to one and it is charged) to the internal structure of the body location in which the weapon was mounted, even if the Expanded Critical Damage rules (see p. 75) are in effect. CASE will stop damage transfer, but the MechWarrior will always take two pilot hits.

**Aerospace Fighters:** The damage is applied to the armor location; if the damage destroys the armor, then any remaining damage is halved (rounded down) and applied to the SI, per standard damage transfer rules.

**Large Craft:** Large Craft cannot disengage a PPC inhibitor.

### Overcharging

A unit can intentionally override the safeguards on a particle projector cannon and overcharge the PPC. However, this dangerous move can have unexpected consequences and automatically results in damage inflicted on the PPC itself.

At any time before firing the weapon, the player announces he is overcharging it. When the controlling player makes a weapon attack with an overcharged PPC, he or she rolls a number of dice equal to the type of PPC fired, based on the Overcharging PPC Table (below). The player rolls those dice and adds the results together. This value is added to the standard Damage Value and heat generated by the weapon that turn.

The weapon automatically takes a critical hit (applied to the topmost unmarked critical slot) when it is overcharged. Additionally, the player then compares the original die roll result to the Feedback Table. If the player rolled only a single die, consult the “3 or more hexes” row; if the player rolled two dice, consult the “2 hexes” row; if the player rolled three dice, consult the “1 hex” row. If the result of the die roll is less than or equal to the relevant number, the PPC catastrophically explodes; use the rules under *Disengaging Inhibitor* (at left) for determining the damage caused by such an explosion (damage applied to the unit is equal to the total Damage Value of the overcharged PPC; the only difference is that instead of a single critical hit, all of the weapon’s critical slots are marked off).

## PPC FEEDBACK TABLE

Target Distance	Avoid Feedback On
1 hex	10+
2 hexes	6+
3 or more hexes	3+

## OVERCHARGING PPC TABLE

Weapon Type	Dice Rolled
Light PPC	1D6
PPC, ER PPC, Snub-nose	2D6
Heavy PPC	3D6

INTRODUCTION

ADVANCED  
GROUND MOVEMENT

ADVANCED  
COMBAT

ADVANCED  
BUILDINGS

ADVANCED  
SUPPORT  
VEHICLES

GENERAL  
RULES

ADVANCED  
SUPPORT VEHICLE  
CONSTRUCTION

ADVANCED  
WEAPONS  
AND EQUIPMENT

INDEX

RECORD SHEETS



**PPC Capacitor:** Overcharging can be used with a PPC capacitor, but regardless of whether or not an explosion occurs, in addition to the single critical hit applied to the PPC, the PPC capacitor slot is marked as destroyed.

### RETRACTABLE BLADE

In Advanced Rules retractable blades have a deadly, if risky attack. Anytime a 'Mech with a retractable blade that is retracted successfully punches, the controlling player can immediately announce that he is extending the retractable blade. This automatically inflicts a possible critical hit in the location successfully struck by the punch attack (this additional possible critical hit is regardless of whether internal structure was damaged or not); the player rolls on the Determining Critical Hit Table, if a 'Mech, or the appropriate Vehicle Critical Hits Table, if a vehicle. In the case of a successful punch against a battle armor unit, a critical hit means the trooper inside the suit structure is automatically eliminated. However, the controlling player must immediately roll 2D6. On a result of 10+, the blade is destroyed (mark off the topmost critical slot).

## HEAT

Under standard rules, though a 'Mech's heat level can rise above 30, it has no additional effect on the 'Mech beyond the power plant shutdown at 30 Heat Points, though the excess heat makes it take longer to restart the 'Mech. The following rules add additional effects to the heat scale above 30 points. This is important because many modern and especially advanced 'Mech designs can build up far more than 30 heat points. With this optional rule, such extreme heat levels can have dire consequences.

For ease of use, the Expanded Heat Scale is included on the Advanced 'Mech Record Sheet at the back of this book.

### AVOIDING SHUTDOWN

The Expanded Heat Scale shows some shutdown-avoid numbers higher than 12. The following optional rule is recommended for use in conjunction with the new heat scale, but can be used in any game.

The controlling player of a unit can make a Piloting Skill Roll to avoid shutdown, because a skilled pilot would know how to override shutdown. To find the base target number, find the appropriate Avoid Number under the Heat Data and apply a -5. Then apply a final modifier based upon the skill of the pilot as shown on the Avoid Shutdown Pilot Skill Rating Modifiers Table. For example, at a heat level of 34, for a Veteran Pilot, the final Modified Target Number would be 8 [14 (34 heat level avoid number) -5 (standard modifier) -1 (veteran pilot) = 8].

### AVOID SHUTDOWN PILOT SKILL RATING MODIFIERS TABLE

Pilot Skill Rating	Modifier
6-7	+1
4-5	+0
2-3	-1
0-1	-2

### EXPANDED HEAT SCALE

Heat Points	Effects
50	Shutdown
49	-9 Movement Points
48	+7 modifier to fire
47	*Pilot damage, avoid on a result of 12
46	Shutdown, avoid on a result of 20+
45	Ammo explosion
44	**System failure, avoid on a result of 10+
43	-8 Movement Points
42	Shutdown, avoid on a result of 18+
41	+6 modifier to fire
40	Ammo explosion, avoid on a result of 12
39	*Pilot damage, avoid on a result of 10+
38	Shutdown, avoid on a result of 16+
37	-7 Movement Points
36	**System failure, avoid on a result of 8+
35	Ammo explosion, avoid on a result of 10+
34	Shutdown, avoid on a result of 14+
33	+5 modifier to fire
32	*Pilot damage, avoid on a result of 8+
31	-6 Movement Points
30	Shutdown, avoid on a result of 12+

\*If the Avoid Roll fails, the pilot takes 1 point of damage. If the 'Mech has suffered a Life Support critical hit, this damage cannot be avoided, and is added to damage normally suffered (see p. 127, *TW*).

\*\* Extreme heat levels can cause critical damage to the 'Mech. If the Avoid Roll fails, roll a hit location on the Front column of the 'Mech Critical Hit Table and apply a single critical hit to that location. Determine the slot hit normally.



*In harsh, deep deserts, heat can be worse than any enemy.*



## REROUTING HEAT SINK COOLANT ('MECHS ONLY)

Heat sinks networks are designed to cool the entire 'Mech, offering maximum flexibility at the expense of efficiency. It is possible to re-route the coolant flow from the cockpit controls, sending more coolant to a specific item of equipment, but denying that coolant to the rest of the 'Mech's systems. This is called linking the heat sink.

When sufficient numbers of heat sinks are linked to the item of equipment, the item is treated as generating slightly less heat than normal, representing a boost in efficiency. To gain this improvement, first calculate the reduced heat output of the item. The heat load reduction is calculated as follows: an item that generates 10 or more heat points when activated (i.e. a PPC, a fusion engine with 2 critical hits and so on) has its heat reduced by 2 points; an item that generates 3 to 9 heat points when activated (i.e. a medium laser, a fusion engine with 1 critical hit, a Inner Sphere large pulse laser, and so on) has its heat reduced by 1 point; items that generate 0 to 2 points of heat (i.e. machine guns, undamaged fusion engines, and so on) do not have their heat reduced.

This reduced heat does not take effect until sufficient heat sinks have been linked to completely handle the reduced heat load. For example, a MechWarrior trying to link double strength heat sinks to an ER PPC would not receive the benefits of the linked heat sinks until 7 DHS were linked to the one weapon.

Heat sinks linked to an item cannot be used to handle heat from other heat sources. A heat sink linked to the engine can dissipate heat from non-jumping movement as well as heat generated by engine critical hits; jump jets must have heat sinks linked to each jump jet individually.

During the End Phase, a player may announce an attempt to link a heat sink. The player makes a standard Piloting Skill Roll, applying all standard modifiers. Only one heat sink may be linked in this fashion per End Phase. Additionally, the heat sink must appear on the Critical Hit Table (heat sinks not shown on the Critical Hit Table are integral to the engine, and so cannot be re-routed to specific systems.) A successful Piloting Skill Roll routes the coolant from that heat sink to one desired component: the engine, one jump jet, or one weapon or other heat-generating component. Mark the link in pencil on the Critical Hit Table.

A failed attempt has no effect. If using the Fumble rule (see p. 75), a fumble actually ruptures a coolant line, recorded as a critical hit against the heat sink the controlling player was attempting to link.

Ending a link similarly is performed one heat sink per End Phase, but success is automatic; no Piloting Skill Roll is needed.

**Coolant Pod:** Coolant Pods (see p. 303) do not affect linked heat sinks, as they are outside the normal coolant distribution network.

**Critical Hits:** If the item a heat sink is linked to is destroyed, the player must reroute any linked heat sinks, using the rules above, before those heat sinks can be used again.

## HEAT SINK COOLANT FAILURE

Despite the wonders of technology and solid maintenance, push a 'Mech's heat too far and venting for emergency pressure relief and evaporative cooling results in a reduction of

coolant inventories to dangerous levels. In some cases, the heat burden reduces the efficiency of heat sinks in a vicious cycle of overheating and efficiency reduction, until the 'Mech is barely able to cool itself. As a result, in extended battles, BattleMechs may need external cooling assistance and coolant replenishment of a coolant truck to get their heat levels under control.

During the End Phase of any turn in which a unit has Heat 5 or higher (meaning heat is being tracked on the Heat Scale that has inflicted some type of modifier), the player rolls 2D6 and applies the modifier from the Heat Sink Coolant Failure Modifier Table based on that level of heat to the die roll result. If the modified result is 10 or higher, a breakdown in the 'Mech's coolant efficiency has occurred. The total heat dissipation capacity of the 'Mech is reduced by 1, starting during the Heat Phase of the following turn.

This is not a critical hit applied to a given heat sink, and so it must be tracked separately. A unit can lose both heat sinks due to damage, as well as multiple strikes against its total heat dissipation from multiple failures of this die roll. If a unit receives enough strikes against its heat dissipation capacity in this manner, depending upon other circumstances (such as engine hits, infernos and so on), a unit may not be able to dissipate any heat at all without the assistance of a coolant truck's coolant system (see below).

## Coolant Systems

Coolant trucks are not only useful for cooling off overheated 'Mechs, but can replace degraded coolant during the midst of a battle (as might occur under the Heat Sink Coolant Failure rule; at left), thus returning a 'Mech to full heat-dissipation capacity.

Any unit with at least 5 tons of liquid storage capacity (for example, the Coolant Truck from *Technical Readout: 3039*) can be used under this rule; the player simply nominates the unit to be carrying the appropriate type of coolant before the start of play. For this rule, any such unit is termed "coolant truck," regardless of what unit actually might mount such storage capacity.

The controlling player of any 'Mech adjacent to a friendly coolant truck at the end of a Movement Phase may announce that the 'Mech is hooking up. Hooking up takes the remainder of the turn, and so the 'Mech may make no attacks. During the Heat Phase of that turn and every Heat Phase thereafter dur-

INTRODUCTION

ADVANCED  
GROUND MOVEMENT

ADVANCED  
COMBAT

ADVANCED  
BUILDINGS

ADVANCED  
SUPPORT  
VEHICLES

GENERAL  
RULES

ADVANCED  
SUPPORT VEHICLE  
CONSTRUCTION

ADVANCED  
WEAPONS  
AND EQUIPMENT

INDEX

RECORD SHEETS

## HEAT SINK COOLANT FAILURE MODIFIER TABLE

Heat Level	Modifier
5-10	+0
11-15	+1
16-20	+2
21-25	+3
26-30	+4
31-35	+5
36-40	+6
41-45	+7
46-50	+8



ing which the 'Mech remains attached, a 'Mech hooked up to a coolant truck can dissipate an additional 15 points of heat. Additionally, for each turn after the first that the 'Mech is continuously hooked up to a coolant truck, remove 2 levels of coolant failure. For example, a 'Mech with a 3-level heat sink reduction due to coolant failures would reduce that number to 1 after the first turn; after the second turn, the drop would be eliminated.

A player may announce his intention to detach a 'Mech from a coolant truck during the End Phase of any turn. Detaching takes up all of the following turn, after which the 'Mech can move and operate normally.

A 'Mech hooked up to a coolant truck is immobile (as is the coolant truck), and so the standard -4 modifier for an immobile target applies to the to-hit number for attacks against it. It can also be the target of aimed shots. The 'Mech stays immobile (i.e. it cannot expend any MPs and is considered immobile) for the entire cooling process, from hookup to detaching, though all its electronics still work, it can make any type of weapon attacks and/or appropriate physical attacks and so on.

If a 'Mech falls or is displaced, the hook-ups are automatically undone; the 'Mech will need to be hooked up once more, using the rules outlined above. Additionally, roll 1D6; on a result of 4 or higher, the hook up is damaged and cannot be used for the remainder of the scenario.

Each coolant truck has five hookup points. Light and medium 'Mechs (up to 55 tons) use a single hookup point to cool down. Heavy and assault 'Mechs (60 tons and up) require two hookup points.

Currently accepted rules of warfare offer a hooked-up 'Mech a degree of immunity from battle; if it makes no attacks, no one will fire on it. If the 'Mech engages in hostile action, however, enemy units may fire at it with impunity. This convention is a point of etiquette rather than a hard-and-fast game rule.

Coolant trucks equipped with flamers or sprayers may fire coolant. A player must announce his intention to fire coolant before using the flamer/sprayer, and firing coolant consumes a "shot" of flamer ammo. Also, firing coolant through a flamer/sprayer reduces the number of hookup points available for other uses (the tank can only pump so much coolant). Each vehicle flamer/sprayer fired reduces the number of available hookups by 1; each heavy flamer fired reduces the number of hookups by 2. A single coolant-equipped vehicle can fire coolant through a maximum of five standard vehicle flamers/sprayers or two heavy flamers and one standard flamer/sprayer; in this case no coolant flows to the hookup points.

A coolant truck may fire coolant at a 'Mech to reduce its heat level, though this does not work nearly as efficiently as hooking up the 'Mech. Resolve the shot as a normal flamer/sprayer attack. If the attack hits, the coolant stream reduces the target's heat level by 2 rather than inflicting damage. A hit by a heavy flamer shooting coolant lowers the target's heat level by 4. Coolant may also be fired at a burning hex or unit to put out the fire. Roll against the to-hit number as with a normal attack, applying the Immobile Target modifier if firing at a hex. If the shot hits the target, the coolant puts out the fire.



• NEW VEHICLE ARC FIRING DIAGRAM •

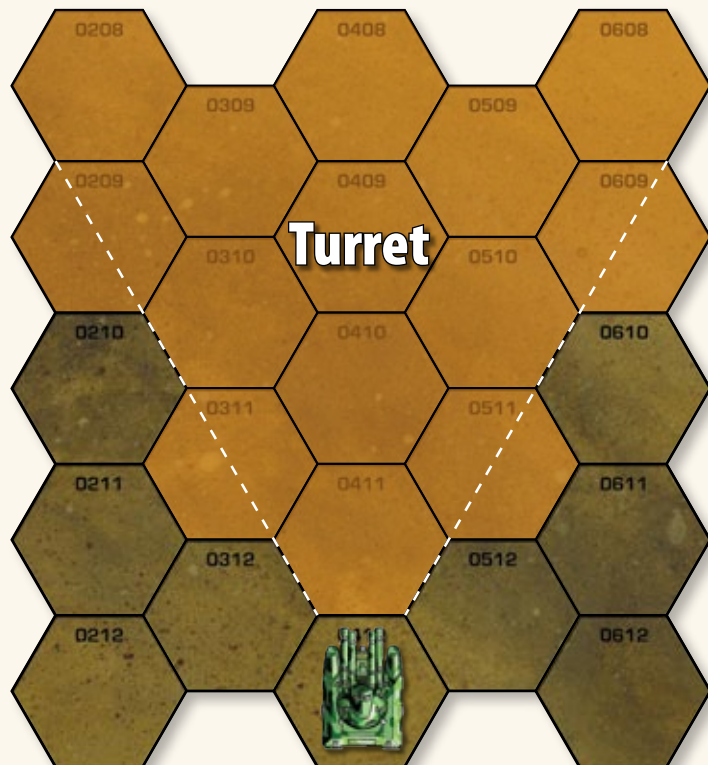

• NEW VEHICLE TURRET ARC DIAGRAM •



# VEHICLES

The following additional rules specifically apply to vehicles in combat.

## FIRING ARCS

In advanced rules, vehicles have unique firing arcs as shown on the New Vehicle Firing Arcs diagram. The diagram also includes all the various firing arcs a vehicle could potentially possess, based on the equipment it mounts (see *Vehicular Sponson Turrets*, p. 348, and rules for mounting two turrets, p. 347).

## VEHICLE EFFECTIVENESS

While the vehicle rules presented in *Total Warfare* increased the effectiveness of vehicles from previous rules sets, vehicles were still carefully maintained at a level that would leave 'Mechs the kings of the battlefield. For those players wishing to further increase the effectiveness of vehicles, the following changes to the Ground Combat Vehicle Hit Location Table and Motive System Damage Table (see p. 193, *TW*) can work wonders. Individual playing groups can pick and choose which of these changes they wish to implement.

**VTOLs and Large Vehicles:** If desired, these same changes can be made to VTOL and Large Vehicle hit location tables.

### Ground Combat Vehicle Hit Location Table

- Remove the critical result from the "8" die roll result on the Side column.
- Remove the potential motive system damage from the "9" die roll result on the Front, Rear and Side columns.

### Motive System Damage Table

- Completely remove the Attack Direction Modifiers.
- Reduce all Vehicle Type Modifiers by 1 (to a minimum of 0).

### VTOL SPECIAL ATTACKS

In advanced-rules play, VTOLs may make strafing and bombing attacks in much the same way as aerospace fighters. The standard rules apply (see pp. 243-246, *TW*), with the following exceptions.

#### Strafing

VTOLs can make strafing attacks in much the same way as aerospace fighters. Use all the same rules for Strafing (see p. 243, *TW*) with the following exceptions.

The controlling player declares the attack during the Movement Phase of a turn, but its effects are not resolved until the end of the Weapon Attack Phase, after all other attacks have been resolved; if there are multiple VTOL strafing/dive-bombing attacks, randomly determine the order in which they are resolved. This means that a unit in the path of the attack that has not yet moved may choose to leave the area and thereby avoid being strafed.



• NEW VEHICLE SPONSON ARC DIAGRAM •



Demolisher II, First Donegal Jaegers (House Steiner)

INTRODUCTION

ADVANCED  
GROUND MOVEMENT

ADVANCED  
COMBAT

ADVANCED  
BUILDINGS

ADVANCED  
SUPPORT  
VEHICLES

GENERAL  
RULES

ADVANCED  
SUPPORT VEHICLE  
CONSTRUCTION

ADVANCED  
WEAPONS  
AND EQUIPMENT

INDEX

RECORD SHEETS



A VTOL that makes a strafing attack may make no other weapon attacks during the same turn (though its AMS may still be used to defend against incoming missile attacks). The VTOL may strafe as it moves over hexes, but must fly over each hex to be strafed. As it strafes, the VTOL must maintain a constant elevation and may not make facing changes. Before and after strafing, the VTOL may move normally.

VTOLs may strafe with one, some or all of its turret- or front-mounted energy weapons.

### Bombing

Like aerospace fighters, VTOLs may carry bombs on external racks, using those rules (see p. 245, *TW*); Safe Thrust Reductions are applied as Cruising MP reductions for VTOLs.

A VTOL may make only one bombing attack per turn, and may not make weapons or strafing attacks in the same turn. As with strafing, the controlling player declares the bombing attack during the Movement Phase. The player indicates the target hex, which must be one that the VTOL flew over during that turn. Though the VTOL may only strike one target hex, it may drop as many bombs as the player desires in that hex in a single turn. The attack is resolved at the end of the Weapon Attack Phase after all other attacks have been resolved (if there are multiple VTOL strafing/dive-bombing attacks, randomly determine the order in which they are resolved), in the same manner as an aerospace fighter's dive-bombing attack (see p. 245, *TW*). Note that unlike an aerospace fighter, which changes altitude during a dive-bombing attack a VTOL does not change elevations during a dive-bombing attack.

---

## INFANTRY

---

The following additional rules specifically apply to infantry in combat.

### DIGGING IN

An infantry unit may safeguard itself from attack by digging in: hiding behind foliage and other ground cover, lying prone or other defensive measures. Digging in is an option in any type of terrain except roads, pavement, buildings and water. The process takes a full turn, during which the infantry unit may not move or attack. If it is attacked during this turn, it is not considered dug in yet and so receives no bonuses.

All attacks against a dug-in unit (regardless of munition type) add a +2 to-hit modifier, except for flamers and area-effect weapons. In addition, damage is not doubled against a dug-in unit in Clear terrain.

The unit remains dug in until it moves; after moving, it must spend another turn to dig in again.

Note that "digging in" in this fashion only applies to the infantry unit in question. Specialized infantry (see *Trench/Fieldworks Engineers*, p. 341) can build a fortified hex that any infantry unit, including mechanized infantry, can enter and automatically receive the "digging in" benefit.

**Mechanized Infantry:** Except in the case of fortified hexes built by appropriately specialized infantry, mechanized infantry may not use the digging-in rule.

### Hitting the Deck

A variation on digging in, hitting the deck is an infantry unit getting their noses close up and personal to the terrain they're in. If an infantry unit does not expend any MP during the Movement Phase, the controlling player may announce that the infantry is "hitting the deck."

All attacks against an infantry unit hitting the deck (regardless of munition type) add a +1 to-hit modifier (including attacks made in the same turn the unit hit the deck), except for flamers and area-effect weapons. However, damage is still doubled against a "hitting the deck" unit in Clear terrain.

Unlike a unit "digging in", however, an infantry unit hitting the deck can still make a weapon attack in the same turn.

The unit remains on the deck until it moves. If an infantry unit on the deck does not move or fire for two turns, it can change to "dug in."

**Anti-Mech Skill Rolls:** Apply a +1 modifier to any Anti-Mech Skill Rolls made by a unit that has hit the deck.

**0 MP:** Any infantry unit that can only move or shoot must designate a facing in the hex when they hit the deck, and the troopers may only fire their weapons in that direction. Use the standard front firing arc to determine which targets the unit can attack. In the following turn, if the unit remains on the deck, the controlling player can designate a new hexside during the Movement Phase (this is not considered an expenditure of MP and so the unit is still on the deck).

### CONVENTIONAL INFANTRY SQUAD DEPLOYMENT

Apply a +1 to-hit modifier to all attacks made against squad-deployed conventional infantry (see *Squad Deployment*, p. 27). This modifier does not apply to infantry platoons reduced by damage to seven or fewer troopers—only infantry initially deployed in squads.

### USING NON-INFANTRY UNITS AS COVER

If an infantry unit occupies the hex of a non-infantry unit that is on the ground (including enemy units), they can use that unit for cover.

At the end of the Movement Phase, after all units have moved, any controlling players with infantry units occupying the hex of a non-infantry unit should nominate a hexside. Any attacks made against the infantry where the direction of attack crosses that hexside apply a +3 to-hit modifier; any attacks made by the infantry unit that cross that hexside apply a +1 to-hit modifier. Any attacks (either by or against the infantry unit) where the attack direction crosses any other hexside apply no additional modifiers.

### BATTLE ARMOR INFANTRY

Battle-armored infantry troopers are supposed to be tough, but some players may feel they are a bit too tough. The following optional rule makes battle-armor units vulnerable to lucky critical hits.

Make the standard die roll to see which trooper is struck by an attack. After resolving damage, make a second die roll. If that die roll result indicates the same trooper where damage was just assigned that trooper is destroyed regardless of the damage just applied, or how much armor remains. If the second result is any other trooper (whether active or not), then the chance for a critical hit is gone and the controlling player should move on to the next attack, if any.



INTRODUCTION

ADVANCED  
GROUND MOVEMENT

ADVANCED  
COMBAT

ADVANCED  
BUILDINGS

ADVANCED  
SUPPORT  
VEHICLES

GENERAL  
RULES

ADVANCED  
SUPPORT VEHICLE  
CONSTRUCTION

ADVANCED  
WEAPONS  
AND EQUIPMENT

INDEX

RECORD SHEETS



# WEAPON RESOLUTION DICE (TIPS AND SUGGESTIONS)

As with movement dice, weapon resolution dice can help speed up and simplify game play, especially if a large number of units are on the board. Keep in mind, however, that weapon resolution dice are not a formal game mechanic—simply an option to make game play smoother. Therefore, all players should agree to their use before game play begins.

Players can use weapon resolution dice in two ways.

The first is when resolving to-hit rolls for multiple weapon attacks simultaneously. For example, the controlling player of a PTR-4D *Penetrator* is firing all six of his medium pulse lasers at the same target. Instead of rolling 2D6 six times, he would use the weapon resolution dice method and roll six different pairs of dice simultaneously for the six medium pulse laser to-hit rolls (each pair a distinct color so that it is quick and easy to see which of the six medium pulse lasers struck the target and which missed). It is important to note that this use of weapon resolution dice should only apply when multiple weapons are attacking with the same modified-to-hit number. Furthermore, it is suggested that such a use of weapon resolution dice only occur when firing multiples of the same weapon. In both instances it is all too easy to get the dice mixed up. For example, if the controlling player of that PTR-4D *Penetrator* tried rolling eight pairs of dice to resolve the six medium pulse lasers as well as the 'Mech's twin extended range large lasers, the chances are the large lasers would have a different modified to-hit number from the medium lasers. If so, the controlling player would have to announce, and then remember, which two sets of 2D6 out of eight sets represent the extended range large lasers, and then once rolled, remember the two different modified to-hit numbers: one for the large lasers and a different one for the six medium pulse lasers. Not only can

this cause confusion for the controlling player, but it can open up the game to unnecessary arguments if the opponent feels the controlling player forgot one of those elements as well.

The second way to use weapon resolution dice is when rolling on the Cluster Hits Table for multiple Cluster Weapons. For example, the controlling player of an SRM Carrier has already resolved that Combat Vehicle's weapon attack to-hit rolls and is now ready to roll on the Cluster Hits Table to determine how many short-range missiles from his various SRM weapons struck the target. Instead of rolling 2D6 multiple times for each Cluster Weapon that struck the target and comparing it to the Cluster Hits Table, weapon resolution dice would allow a player to make a single roll with multiple pairs of dice to quickly determine how many clusters of damage from each Cluster Weapon actually struck the target. (As a side note, if the controlling player was the first to use weapon resolution dice, instead of rolling 2D6 nine times for the carrier's nine SRM-6s, he or she could have made one roll of nine distinct pairs of 2D6 dice.) As with resolving multiple weapon attacks, it is suggested that weapon resolution dice only be employed this way when rolling multiple Cluster Weapons of the same type in an effort to avoid confusion.

Given the nature of damage resolution, weapon resolution dice should not be used to resolve hit locations and damage to target.

**Note:** The way in which a player determines locations and damage to target for announced attacks can be an important tactic in game play. For example, if the controlling player of an AS7-D *Atlas* hits a target with the *Atlas*' AC/20 and SRM-6, it will usually be better to determine the location and apply the damage of the AC/20 first in an effort to strip the hit location of its armor. Then the controlling player would determine how many SRMs struck the target using the Cluster Hits Table, and finally determine location and damage to target for each SRM that struck; that is, if the AC/20 stripped the location struck of armor, then the multiple rolls to determine location for the missile hits provide a higher probability of hitting the now defenseless location's internal structure (perhaps several times), thus resulting in several chances for a critical hit.



Word of Blake battle armor launch a trap to try and destroy a Crescent Hawk's Cestus.

# BOOM!

Jason Schmetzer

**JUBILEE DROPPORT  
MARANTHA  
MAGISTRACY OF CANOPUS  
14 MARCH 3071**

The sentry died with barely a sound.

Vincent crept up behind him, cat-quiet on the soft soles of his boots, and slid his assault rifle around on its sling behind him. The Blakist guard was looking the other way, watching one of the DropShips squatting on the tarmac as a BattleMech walked sentry-go across the field. Vincent allowed himself a grin as he came out of his crouch, arms reaching, hands open and tensed.

In a smooth motion he slid forward, one hand around the Blakist's head to cup his chin and the other on the back of his helmet. "Peace of Blake," he whispered, and twisted. There was a moment's resistance—*forty kilograms of pressure*, his mind filled in—and then a slight pop, like a green stick breaking, and then he was holding the sentry's entire weight. The body sighed as the zealot's last breath slithered out of it, but Vincent laid him down before the man's bowels could release.

"Clear," he whispered.

Three black shadows detached themselves from the base of the retaining wall behind him and sprinted forward, covering the twenty meters in seconds. They were garbed identically to him, each in a black sneaksuit with web-harnesses festooned with silent pouches. Each of them held an assault rifle toward the port.

"A knife would have worked," the leftmost one said. Sheila was always a distance killer, Vincent knew. He smiled—it was an old argument—and reached down to tap the dead man's body armor.

Sheila shrugged, nearly invisible in the dark. "I would have gotten him in the neck," she said.

"Vehicle," Franks whispered, twisting slightly to bring his Ebony assault rifle to bear.

Vincent crouched over the sentry and brought his own Ebony around from where he'd slung it behind him. He didn't look toward his hands, instead judging the distance between the team and the approaching truck. *Four hundred meters*, he thought. A flick of his thumb dialed the power selector on the Ebony's receiver to high.

"We need transport," he said. "Dalton." He beckoned toward the body, then re-slung his rifle to grasp the dead man's feet. The third Magistrate operator took the Blakist's forearms and together they carried the man the ten meters to the roadway. Two swings for momentum and then they tossed the body into the center of the road.

"It stops, we take it," he said, bringing his rifle around again.

"It's a Pit Bull," Sheila whispered.

"Watch the cargo bed for troops," he ordered. The lights of the truck were starting to cast a shadow behind the body. They'd be spotting it any minute now. He



looked to Sheila. "Would have been kind of hard to hide the knife wound to his neck, don't you think?"

Vincent watched the truck slow suddenly as the driver saw the body, and tried to keep his mind on the mission. The truck itself was a symbol of the troubles, he knew. Pit Bulls were inexpensive, all-terrain cargo trucks built primarily in the Taurian Concordat. He'd ridden in any number of identical vehicles during his stint in the Magistracy Armed Forces, but he'd never been comfortable with them. They came from the Concordat, after all.

*Can't we even make a decent enough truck that we don't have to buy other people's?*

That he got to shoot at this one, and kill the Blakist bastards driving it, was a welcome bonus. He'd spent ten years in the MIM, the last year leading this cell of the Ebon Magistrate. The Blakists had come to the Magistracy to bring their Jihad to Vincent's home. He didn't need to wait for orders from his control; he knew what the Magestrix would say. Kill them. Kill them all, and make certain they know the Magistracy is not their playground.

The Pit Bull stopped, groaning on its oversized axles. Two men jumped out, one from each side of the cab. The cargo bed was stacked high with containers but the light was too low for Vincent to read the icons on the side. They left the truck running as they jogged toward the sentry's body. Vincent, from his position on the rightmost edge of the team, took the nearest Blakist. Sheila and Franks would target the left, and knew to do it without being ordered to. The Ebons spent enough time training for these situations that they didn't need to be told what to do.

"Blake's blood," Vincent heard, as one of the new arrivals knelt by the body. "You okay, pal?" The other man remained standing, looking around. His hand dipped toward his belt. Vincent fired. The others fired.

The Ebony laser assault rifle was a silent weapon, designed from the start for Ebon operations. Along with the shock-resistant polymer frame and the variable power function, it also had an all-but-invisible pulse. The four lasers fired within a second of each other and the only sound was the muted click of the firing mechanism engaging. There were no showy flashes of neon light or earth-shattering screeches of power. The two men near the body both had heads; four rifles fired at two targets, and then their heads were gone.

Vincent was on his feet before his target had finished falling to the ground. He didn't bother going to check the bodies; without heads they weren't a threat to anyone, and he already knew the sentry was dead. Instead he moved to the Pit Bull and mounted the cargo bed. Up close he read the icons on the containers, and a tight, feral smile broke out on his face.

"Boom," he whispered.

Sheila climbed into the bed with him while Dalton and Franks climbed into the cab. The Pit Bull lurched into motion, continuing on the way it had been going when they stopped it. They had an appearance to make on the opposite side of the Port, but turning off the road and going across the fields would only attract attention.

"Primary target," Vincent said, trusting the whisper-mike on his throat to transmit his words to the Ebon driving. Franks nodded his head once and turned at the next intersection, pointing



the Pit Bull toward the squat shape of the *Mule*-class DropShip in the distance. Vincent slung his rifle, pushing it around behind him and letting the friction sling draw it tightly against the small of his back. He reached into the left thigh pocket of his sneaksuit.

Sheila looked at him. "The DropShip?"

Vincent grinned and slapped the container beside him. "Boom."



"Mech."

Vincent looked up from the third container he was working on. A white-painted Word of Blake BattleMech was coming toward them. It was a light 'Mech, a *Commando*, but it was still more powerful than anything the Ebons had at their command. "Rifles off," he said, reaching behind him to pull the power pack from the Ebony's butt. With no power, the sophisticated laser assault rifle became a quiescent mass of plaster and polymer.

"We're still a klick away," Sheila said.

"And then we've got to get aboard," Vincent said, not taking his eyes off the *Commando*. "So let's worry about what's in front of us right now, shall we?"

The *Commando* wasn't moving with any more purpose than its already established patrol pattern. Vincent could well imagine the tedium of walking a 'Mech across the same ground again and again, waiting for something to happen. Either the MechWarrior would be ultra-sensitive, checking every sensor contact out of sheer boredom, or he'd simply be bored out of his mind and just keep walking until the end of his shift. Vincent knew which type of pilot he'd be, but he was hoping for the other.

"If it shoots?" Sheila asked.

"Then we die," Vincent said.

The *Commando* came abreast of them and passed, without so much as a pause.

"Half a klick," Franks reported. "Two minutes."

Vincent looked forward, toward the mass of DropShip that was rapidly blotting out everything else on the landscape. This close he could see the landing ramps still closed, as if the ship was buttoned up for launch. For a moment he was afraid they were too late, but the landscape around the massive vessel still crawled with vehicles and personnel. He smiled after a moment. It would take the massive ground tug a while to re-hitch trailers and get clear of the blast radius of the *Mule's* drive.

"Warehouse," he ordered.

The *Commando* continued along its patrol route, its pilot safely ignoring any danger around him in his single-minded pursuit of the end of his shift. The Pit Bull turned away from the DropShip and toward the low line of warehouses in the distance.

"We're not going to the DropShip?" Sheila asked, as she reinserted her power pack in the Ebony's butt.

"Not just yet," Vincent said, returning to his wiring. "And not in this truck."



Vincent pounded on the cab of the truck and pointed. "That one, over there." The warehouse he indicated was virtually deserted, but he saw the telltale scuffs on the tarmac out front that told him what he sought was inside. Franks dipped his head once and guided the Pit Bull toward it. He swung the front end of the vehicle around and then switched to reverse, backing into the doorway so that the cargo bed was the first part of the truck through, as if they were expecting to load more cargo.

"Hey!" a laborer shouted. Vincent looked across the containers at him, eyes narrowed. If it was a Canopian citizen he'd simply incapacitate him. There was no need to harm those who were just trying to earn an honest living. Wars came and went but cargoes always needed handling. "You can't bring that crap in here, friend. This is a restricted warehouse."

"Orders," Sheila shouted back, as Franks gunned the engine one last time before he shut the big diesel down. A surreptitious swipe unclipped her rifle from its harness; Vincent caught it as she stepped around him. "The Adept out there told us to bring it here." Vincent smiled, impressed by her tactic.

"Adept Kline?" the man asked.

"That's the one," Sheila said. Her hand moved too quickly for him to see and there was a pop. The laborer collapsed and Sheila turned away, revealing the suppressed pistol she'd drawn from the holster low on her thigh. Franks and Dalton piled out of the truck's cab and came around the back, looking to Vincent.

"Exos." He pointed to a rack against the side of the wall, where a brace of bulky Gorilla exoskeletons were waiting. "Get these drums unloaded." He turned and waved a hand at Franks to hold up. "Go back out and get us one of those baggage jitneys," he said. "Three cars at least, empty if you can find it quickly."

The slender man nodded once and trotted out the warehouse door. Vincent followed Sheila and Dalton toward the racked exoskeletons. They were simple muscle-amplification suits, used by laborers across the Human Sphere to make moving bulk items easier. While nowhere near as sophisticated as the powered combat armor the MIM had access to, the Gorillas were simple, reliable technology.

And they'd move the bombs like they were weightless.

Each drum was a 50-kilo container of concentrated fertilizer, intended for the reforestation project at Indian Island. There were six in the back of the Pit Bull, and Vincent had spent the drive across the DropPort dousing each in diesel fuel, then wiring them together with the initiator charges from his thigh pouch. The trick now would be getting them close enough to the DropShip to actually do any damage. Which was where the jitney came in, if they could get back across the tarmac without anyone catching on.

"Boom," Vincent whispered.

Franks reappeared at the door just as they were getting the body of the laborer back into the now-empty Pit Bull. He jumped in the cab of the truck and fired the diesel up before pulling the truck out. The warehouse was filled with the sickly-pungent tang of diesel exhaust by the time the truck was gone, but Vincent barely noticed. He stomped his exo to the doorway and looked out, being patient and waiting for his eyes to adjust.

The *Commando* he found almost immediately, still stalking its way around the tarmac. Vincent smiled at that, thinking of what his commander would have said about such a predictable patrol routine when he'd been on tour with the MAF. It made him feel better about this mission, knowing that even the high and mighty Word of Blake carried idiots on its rolls.

There was still traffic around the *Mule*, and more and more cargo carriers and baggage jitneys going toward it still. His eyes rolled across the mélange of hovercraft, tracked crawlers, and wheeled cargo vehicles until he saw the one he wanted. He looked behind him, saw the others ready with the bombs. He brought his Ebony around, thumbing the selector from high-power to extended-range, shouldered it.

"Vincent," Sheila said. He fired.

The fuel truck he'd targeted, almost a full kilometer distant, exploded as the laser pulse stabbed into the thin metal shell. The explosion cast light for a square kilometer. Vincent watched the

rolling shadows as Franks pulled the jitney up in front of the warehouse. "You sure that was smart?" he asked.

Vincent smiled. "Not at all... but it should keep their attention over there."

The others loaded the containers into the three-trailer jitney while Vincent shed his Gorilla suit. He beckoned the others back into the warehouse and pointed toward an access stair. "I want you three to get up there and cover me," he said.

"You're kidding," Dalton said.

"It doesn't take four people to drive that thing," Vincent said, relishing his Ebony now that he was out of the exoskeleton. "I'll take it out to the DropShip and leave it. Then one of you can tag the containers from here and we'll all get out in the confusion."

"And when something goes wrong?" Sheila asked.

*Not if, when,* Vincent thought. *Good girl.* "Then you kill it," he said, and walked out.

The jitney's controls were simple to the point of imbecility. Two foot pedals, one marked "Go" and the other "Stop" and a steering bar. He climbed into the driver's couch and pushed the "Go" pedal, turning the bar toward the *Mule*. There weren't any obstacles on the road, so Vincent took the opportunity to look around. *It's always a good idea to see how the bad guys react to bad news,* he thought.

Emergency vehicles were already emerging from the hardened shelters they hunkered in when not needed. He looked toward the military reservation on the western edge of the port but saw little response; evidently the Word figured that Magistracy crews could handle Magistracy problems. That was good news for him. The big *Mule* with the broadsword painted on it looked open and inviting. Vincent grinned and looked the other way.

The *Commando* was running toward the explosion. Vincent shook his head and started to turn away, but then jerked his head back as the twenty-five ton BattleMech sprinted past the flaming wreck and kept coming, directly toward the *Mule*. "Shit," he breathed, and smashed his foot down on the "Go" pedal. The jitney lurched and gained another five kph, but that was it.

"Vincent," his earbud whispered.

"I see it," he growled.

"We can't kill that thing," Franks said.

"I know," Vincent said.

The *Commando* jerked and angled toward the warehouse. Vincent looked at it, confused. The radios should have been so low-powered as to be undetectable, especially through the sure-to-be-cluttered RF frequencies of the port. Then a white-hot bloom of light flared on the 'Mech's faceplate canopy, and Vincent understood.

"Sheila," he whispered.

"Get to the ship," she said. The warehouse was still a kilometer distant. The Ebons' assault rifles could make that stretch. Two more spots of luminescence flared to life on the *Commando's* head before the 'Mech pounded past. Franks and Dalton.

"Displace!" he shouted, twisting in his seat to follow the 'Mech.

"The target, Vincent! The mission!"

Telltale puffs of scintillating light showed where the Ebons were hitting the *Commando's* tough armor, but the damage their rifles could do to even the lightest BattleMech was infinitesimal. The *Commando*, sprinting forward in multi-meter strides, was already raising its arm-mounted weapons to bear on the warehouse. It fired.

The building exploded.

Vincent turned forward again. The DropShip filled the jitney's windscreen as he approached. There were marines out now, gray-clad Word of Blake infantrymen with rifles directing the vehicles away from the DropShip. Vincent kept the jitney on course, ignoring the wave-offs from soldiers and directors alike. The *Mule's* squat stern clutched above the tarmac, with just enough space for the fusion torch's mighty exhaust to clear to lift the ship free of a planet's gravity. The massive legs that supported the vessel were splayed, stressed with the weight of the 11,200 ton DropShip. Vincent steered for the small space between the nearest leg and the DropShip's hull.

A bullet ricocheted off the tarmac in front of him. He looked to the side, saw the infantryman adjusting his aim to the jitney's driver's carriage. Vincent snarled at the man, bringing his Ebony around one-handed and stabbing a laser pulse at him. The soldier dodged to the side, safe.

For the moment.

Vincent let the sling take the rifle and grabbed the steering bar with both hands, jerking the jitney to the side around the curve of the *Mule's* stern. He leaned out of the cab, pulling the rifle free, and looked back, watching the trailers curl around behind him. He saw the canvas flaps swing open, saw the barrels secured together. He looked the other way.

The *Commando* was running toward him, arms raised. Vincent saw the focusing lens of the medium laser in the 'Mech's right forearm begin to glow as the MechWarrior preheated the laser. He looked away, back at the trailers, and raised the Ebony.

"For the Magestrix," he muttered, and fired.

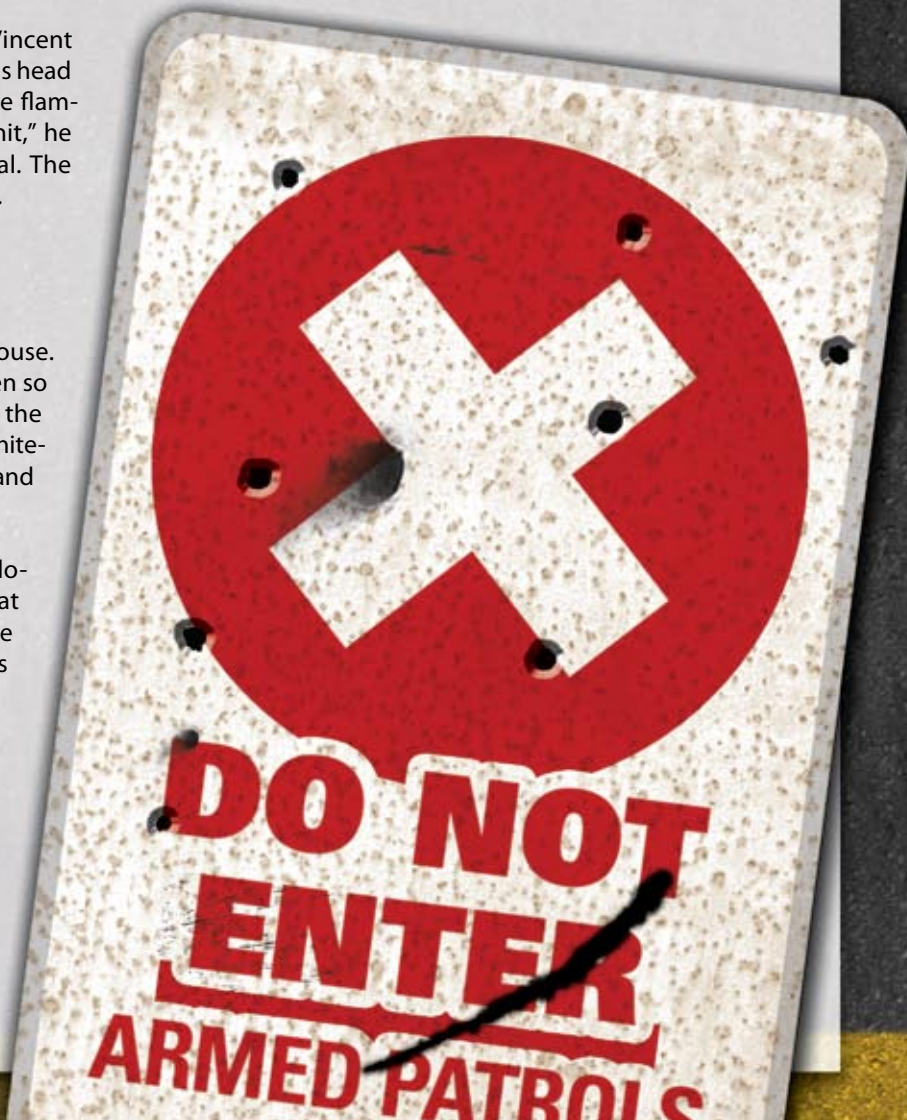



DK

*A St. Ives Lancers' UrbanMech surveys the price of urban warfare.*

Though the building rules in standard *Classic BattleTech* can seem a little complicated at first, they are still designed with ease of use in mind. The advanced rules for buildings in this section introduce additional building classifications and game play options, while offering more “realistic” choices for damaging buildings, building collapse and so on.

This section allows for the “construction” of buildings that include elevators, turrets, armor, weapons and more, a process that will reference the Mobile Structures rules in *Advanced Support Vehicles Construction* (see p. 236). However, this is merely a reference guide for players interested in more advanced and sophisticated static building designs, rather than in Mobile Structures themselves, whose effect in game play is covered under *Advanced Ground Rules* (see p. 18).

**Note:** These rules do not provide details on how to use the various buildings in a campaign, but instead are focused on how they interact with units during a stand-alone *Classic BattleTech* game. Campaign rules for how various building types can affect a much larger-scale war will appear in detail in *Interstellar Operations*.

### STRUCTURE RECORD SHEET

Players interested in using these rules will find it helpful to track the condition and capabilities of any advanced buildings using the Structure Record Sheets found in the back of this book. Each sheet may be used to track one or more structures, using the hexagonal grids to determine their size and shape. To differentiate an advanced building from a Mobile Structure, simply note a motive type of “Static” on the Structure Record Sheet. As desired, players may use multiple record sheets to track larger or more extensive cityscapes.

## ADVANCED BUILDING CLASSIFICATIONS

Under standard *Total Warfare* rules, a single, generic “building” structure is used, with four broad categories covering every type of building available. This generic term, however, does not truly cover the myriad of static structures that exist in the *Classic BattleTech* universe.

The following section introduces a range of buildings through the use of an expanded classification system, while retaining the building-type nomenclature (Light, Medium, Heavy and Hardened) used in *Total Warfare* to denote buildings of varying levels of overall strength and resiliency.

The Building Classification and Type Table on the following page outlines all of the advanced buildings covered here, including classification and type, their basic CF, maximum armor allowed per hex, maximum size (in hexes and levels), the MP cost of movement into such building hexes and the Piloting/Driving Skill modifiers for such movement. If an “NA” appears in both the MP Cost Per Hex and Piloting/Driving Skill Modifier columns, then that building hex cannot be entered by a unit until the hex is reduced to rubble (see *Large Doors*, p. 138, for the exception).

Following the table, the *Building Classifications* section provides additional rules and details covering all the buildings described on the table.

**Note:** Unless specifically stated otherwise, all Buildings rules presented on pages 166-179 of *Total Warfare* still apply.

**Building Sizes:** The building sizes presented in these rules represent an abstraction for game play and construction purposes,



## BUILDING CLASSIFICATION AND TYPE TABLE

Classification/Type	Construction Factor (CF)*	Max Armor (per hex)	Max Size (Hexes/Levels)	MP Cost Per Hex†	Piloting/Driving Skill Modifier	Damage Scaling: Damage to Building/ Damage to Units‡
<i>Cost to Enter Any Hex</i> 1						
Tent	1–2	—	1/1	+0	—	x1/x0
Hangar		—				
Light	1–8		10/7	+0	+0†	x1/x0.5
Medium	9–16		14/10	+1	+0†	x1/x0.5
Heavy	17–45		18/13	+2	+1†	x1/x0.5
Hardened	46–75		20/14	+3	+3†	x1/x0.5
Standard§		—				
Light	1–15		6/5	+1	+0	x1/x1
Medium	16–40		8/8	+2	+1	x1/x1
Heavy	41–90		10/10	+3	+2	x1/x1
Fence	1	—	—/3	+1††	—	x1/x0
Wall		CF x 1				
Light	1–15		—/4	+1	+0	x1/x0.5
Medium	16–40		—/6	+2	+0	x1/x0.5
Heavy	41–90		—/8	+3	+1	x1/x0.5
Hardened	91–150		—/10	+4	+3	x1/x0.5
Bridge		—				
Light	1–15		—	NA‡‡	NA‡‡	x1/x1
Medium	16–40		—	NA‡‡	NA‡‡	x1/x1
Heavy	41–90		—	NA‡‡	NA‡‡	x1/x1
Hardened	91–150		—	NA‡‡	NA‡‡	x1/x1
Rail	151–650		—	NA‡‡	NA‡‡	x1/x1
Gun Emplacement		CF x 1				
Light	1–15		1/1	NA	NA	x0.5/x2
Medium	16–40		1/1	NA	NA	x0.5/x2
Heavy	41–90		1/1	NA	NA	x0.5/x2
Hardened	91–150		1/1	NA	NA	x0.5/x2
Fortress		CF x 1				
Medium	16–40		12/15	+3	+2	x0.5/x2
Heavy	41–90		15/20	+4	+3	x0.5/x2
Hardened	91–150		20/30	+5	+4	x0.5/x2
Castles Brian§§		CF x 2**				
Heavy	35–90		20/10	+4	+4	Capital/Capital**
Hardened	91–150		30/15	+5	+5	Capital/Capital**

\*See pp. 166–167, *TW*. The listed CFs show the range applicable to each building type. If a scenario does not specify a building's CF, assume that all its hexes have the maximum CF possible for that building type and classification.

†Infantry (except mechanized infantry) pay only 1 MP to enter a building hex regardless of building type; ProtoMechs and mechanized infantry pay only 2 MP to enter any building hex except for tents and fences (which cost only 1 MP). Hangars apply MP and Piloting Skill modifiers only when entering from outside, unless other factors apply (see *Hangars*, p. 116).

‡Round all damage down; if the damage is reduced to 0 or less, no damage is applied.

§As detailed in *TW*, except there is no Hardened type.

††Only applies to conventional infantry using Ground MP.

‡‡Units move over bridges (never through them) as though traveling on a road.

§§Area-effect weapons do not double their damage against Castles Brian hexes.

\*\*Castles Brian use capital-scale damage, as noted under *Scale* (see p. 238, *TW*). See *Scaled Damage* (p. 126) for more information.

INTRODUCTION

ADVANCED  
GROUND MOVEMENT

ADVANCED  
COMBAT

ADVANCED  
BUILDINGS

ADVANCED  
SUPPORT  
VEHICLES

GENERAL  
RULES

ADVANCED  
SUPPORT VEHICLE  
CONSTRUCTION

ADVANCED  
WEAPONS  
AND EQUIPMENT

INDEX

RECORD SHEETS



with horizontal “area” represented by hexes 30 meters across and vertical height represented by “levels” 6 meters tall. In reality, buildings may be constructed with far more variety in both area and height, but for purposes of these rules, such details have little impact on the building’s game play effects.

**Damage Scaling:** In addition to the CF of a building type, building classifications change the way in which damage is applied, as noted on the Damage Scaling column of the table (see *Scaled Damage*, p. 126).

## BUILDING CLASSIFICATIONS

The following entries define each building classification and list any unique rules for each beyond those given on the table.

**Building Construction:** Each of these building classifications can be enhanced (some more than others) by several different types of construction options, as described in *Building Construction*, p. 128.

### Tents

The term “tent” applies to any non-permanent or semi-permanent structure lighter than any other fixed structure type. Tents are usually makeshift or collapsible structures that offer some protection from the elements but negligible protection against damage. Tents do not affect or impede the movement of battlefield units into or through their hexes, and are automatically destroyed if any unit type weighing 5 tons or more attempts to enter them. Units passing through a tent hex do not require a Piloting Skill Roll.

Units inside a tent suffer the full damage from any attack delivered against them.

### Hangars

Hangars feature wide-open interiors for housing ‘Mechs, aircraft and other large vehicles or equipment. Most types of warehouses and some large commercial structures also fit into the hangar category.

Unless building design features and equipment create some form of clutter, units moving between hexes inside an “empty” hangar expend only 1 MP, suffer no damage and inflict no damage to the hangar’s CF—as long as the hangar ceiling is high enough to accommodate the unit. A Level 1 hangar can accommodate vehicles, infantry and ProtoMechs, while Level 2 or higher hangars can accommodate ‘Mechs as well (see the Unit Heights Table, p. 99, *TW*, for reference).

If a hangar lacks the height necessary to accommodate the unit, or if the unit is moving through the hangar’s walls, the hangar suffers damage as normal for the unit’s passage, and any movement and piloting modifiers based on its construction will apply as if passing through a standard building.

If advanced building movement is being used, and the hangar features equipment of any kind (including unspecified equipment), additional movement costs and Piloting Skill modifiers will apply as well, even if the hangar is large enough and the unit is already within its walls. However, the structure’s open design reduces these effects, and the building sustains damage only if the unit fails a Piloting Skill Roll.

Hangars generally have no suitable floors above ground level, so any unit in a hangar hex must be on the structure’s ground floor or its roof.

### Standard Buildings

Standard buildings (buildings as presented in *Total Warfare*) represent homes, office complexes and other mostly civilian structures that contain interior spaces for rooms and hallways.

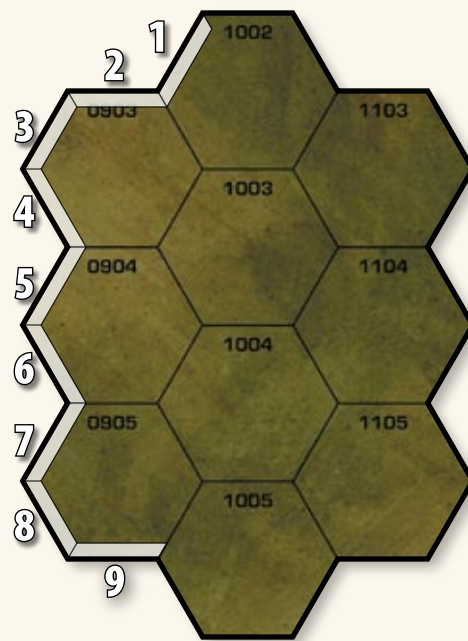

• WALL DIAGRAM •

### Walls

Not strictly buildings, walls are simple structures with no enclosed spaces, generally used as a basic static defense against ground forces or a simple delineation of property lines. Under these rules, walls are not part of a building, but stand-alone structures.

Walls are always placed along hexsides, with each hexside treated as a separate structure for purposes of damage tracking and movement effects. Units can occupy hexes containing walls, but in many such cases, the unit’s controlling player must declare whether the unit is standing on ground level alongside the wall or on the wall itself (and, if standing upon the wall, which wall segment it is standing upon). Place a counter or die with the unit to indicate when it is standing on the wall. For range purposes, an attacking unit treats a wall section (and any units thereon) as if it is located in the nearest of the two hexes it borders.

**Fences:** The lightest form of wall—so much so that they have their own entry on the Building Classification and Type Table—fences represent an obstacle only to conventional infantry that are limited to Ground MP (including foot infantry, motorized infantry and most mechanized infantry). All other units suffer no movement penalties to pass through a fence hexside, and require no Piloting Skill Rolls when doing so.

Like walls, fences are always placed along hexsides, but cannot support the weight of any unit climbing on them.

### Bridges

Under standard rules, bridges are considered both structures and roads (or rails, as appropriate). The advanced rules treat bridges as special walls with roads (or rails) running along them. All wall rules apply, with the following additions.

Unlike walls, bridges pass through the middle of hexes. Each bridge hex has its own CF, like a building, which reflects its external weight and damage capacity. If a unit’s tonnage exceeds the CF of a bridge hex, or the bridge hex’s CF is reduced to 0 or

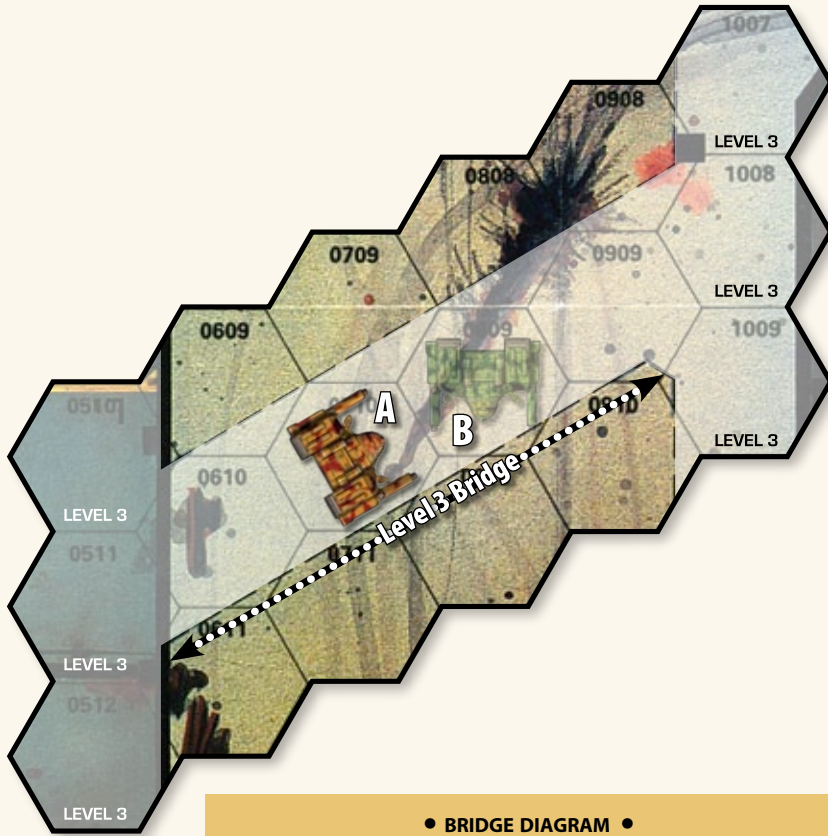

• BRIDGE DIAGRAM •

less, the hex collapses. Furthermore, any bridge hexes that are completely cut off from both ends of a bridge (such as through the collapse of bridge hexes on both ends), these isolated bridge hexes will collapse as well. (Bridge hexes that are still connected by a continuous bridge length to either end point of the structure will remain standing.)

Every bridge starts and ends with a road hex that has the same elevation as the underlying terrain. The difference in elevations between opposite ends of a bridge may not vary by more than 1 level per hex of bridge length (so a bridge that runs 5 hexes from start to finish may not be constructed if its start and end points are more than 5 levels in height apart). For movement and line of sight purposes, units upon a bridge must first determine the bridge's height at the current hex (see Multi-Level Bridges, at right). For the sake of simplicity, multiple bridges may not occupy the same level and hex at the same time.

In most cases (notably excepting the start and end hexes) the terrain below a bridge is treated as a lower level that may be occupied by battlefield units. (Bridges represent a rare instance in which a single non-building hex can have two distinct levels.) For units upon a bridge, the underlying terrain is considered to be either road or rail (as appropriate).

Therefore, a unit in a bridge hex may be on the bridge or under it (see diagram above); the controlling player decides and should clearly indicate the unit's position with a die or counter. Note that a unit may enter a bridge hex and be considered underneath the bridge, provided the level of the underlying hex plus the height of the unit is equal to or less

than the level of the bridge. If a unit cannot move underneath the bridge, the unit must move onto the bridge as if the move were a level change.

**Multi-Level Bridges:** Bridges that change elevation levels between their start and end points as described above must identify their height along each hex traversed. For simplicity's sake, this elevation change must be steady, linear and spread across the entire length of the bridge, with no more than 1 elevation level of change per hex of bridge. To compute the exact rate at which a bridge's elevation changes, divide the height difference (in levels) between the start and end hexes by the bridge's length (in hexes), and do not round the result. For each hex along the bridge, starting from its lowest point, add this value to the bridge's height, rounding normally (.5 rounds up).

For example, if a bridge runs 8 hexes long, but changes 2 levels in the process (starting from a terrain height of 5 levels to a terrain height of 7 levels), each hex of bridge would add 0.25 levels to the starting height. At Hex 0 (the first bridge hex), this would mean the bridge is at Level 5. At 1 hex in, it would be 5 levels high ( $5 + 0.25 = 5.25$ , rounded down to 5). At 2 hexes, it would be 6 levels high ( $5.25 + .25 = 5.5$ , rounded up to 6); and again at 3 hexes ( $5.5 + .25 = 5.75$ , rounded up to 6) through 5 hexes ( $[5.75 + .25 = 6]$  at Hex 4;  $[6 + .25 = 6.25$ , rounded down to 6] at Hex 5). At Hex 6 and beyond, the bridge will be at Level 7 ( $[6.25 + .25 = 6.5$ , round up to 7] at Hex 6;  $[6.5 + .25 = 6.75$ , round up to 7] at Hex 7, and  $[6.75 + .25 = 7]$  at Hex 8).

### Gun Emplacements

Gun emplacements are single-hex buildings designed strictly to provide a weapons platform and protection for the crew manning those weapons. A variety of weapons and other special structure equipment can be mounted in a gun emplacement (see *Building Construction*, p. 128). Furthermore, unlike other building types, gun emplacements have minimal interior space, and so cannot be "entered" as a building by non-infantry units. Instead, they are largely treated as a stationary vehicular unit for purposes of stacking and making or receiving attacks, but as a building for tracking damage.

### Fortresses

Fortresses represent any type of heavy military building, including bunkers, guard towers and installations.

Like gun emplacements, fortresses can mount a variety of special equipment and weapons (see *Building Construction*, p. 128).

### Castles Brian

Castles Brian represent the pinnacle of military-grade fortifications. Pioneered by the Terran Hegemony at the height of its power, each represents some of the most hardened structural

INTRODUCTION

ADVANCED  
GROUND MOVEMENT

ADVANCED  
COMBAT

ADVANCED  
BUILDINGS

ADVANCED  
SUPPORT  
VEHICLES

GENERAL  
RULES

ADVANCED  
SUPPORT VEHICLE  
CONSTRUCTION

ADVANCED  
WEAPONS  
AND EQUIPMENT

INDEX

RECORD SHEETS



material created by man, often strengthened further by burying the bulk of their complexes into local terrain (such as inside a mountain). Almost impregnable, often it takes nothing short of a nuclear blast or heavy orbital bombardment to significantly damage such structures.

Like fortresses and gun emplacements, Castles Brian can mount a variety of special equipment and weapons. Unlike these other structures, they can support far more weight because they use capital-scale Construction Factors, which apply not only to how they sustain damage and support external loads, but also to how much internal weight capacity they receive during construction (see *Building Construction*, p. 128). Furthermore, these buildings are ideally suited to sub-surface use, and may be constructed as underground and underwater buildings with far fewer restrictions on their design.

Castles Brian are also immune to the damage-doubling effect of area-effect weapons, and feature environmental sealing by default.

Castles Brian are almost never built small or as single structures, but almost always form the basis of a massive semi-subterranean complex. For a rough guide on the construction of a Castles Brian complex, see *Castles Brian Complexes*, p. 141.

## STANDARD RULES EXPANSIONS

The following sections expand on various standard rules used for buildings in *Total Warfare*, as they apply to the advanced building rules.

### MOVING THROUGH ADVANCED BUILDINGS

The standard *Classic BattleTech* rules (see pp. 166-179, *TW*) cover the effects of moving units within and through fairly abstracted buildings for speed of game play. Advanced buildings, however, often possess additional features that can further complicate movement into and within such structures. The following expanded rules present additional features intended to better simulate the effects of moving into and conducting combat within and around buildings.

#### Climbing Buildings

Under standard game rules, ascending to the roof of a building requires a non-infantry unit to possess VTOL capability or sufficient Jumping MP to reach and land on the rooftop, while other units may ascend to the roof from inside the building itself. Under these advanced rules, 'Mechs and ProtoMechs with hand actuators, as well as any infantry unit (other than those with Mechanized or Motorized movement types) may also climb the building's exterior to reach the rooftop.

For 'Mechs and ProtoMechs, this action follows the same rules for climbing described on p. 22, but inflicts damage to the hex's CF as through the unit had entered the hex normally (reflecting the stress of climbing the vertical surface). For infantry units, this action is the same as ascending a building from the inside, at a cost of 1 MP per level, but such units receive no defensive benefits from being inside the structure if attacked while doing so, nor do they inflict any damage to the building in the process. 'Mechs and ProtoMechs climbing buildings in this manner may use only

rear-mounted weapons and may not execute any physical attacks; infantry units climbing a building may make attacks as well, but halve any damage values when doing so (to reflect the difficulties of firing weapons while hanging onto a building for dear life).

**Climbing and CF:** A climbing unit whose tonnage exceeds the CF of the building hex it is trying to climb (after accounting for the damage to the building's CF caused by climbing it, as described above) will cause a collapse and suffer an automatic fall. If using the standard building rules, the entire hex will collapse and the unit will fall from its current level (before it started to ascend). If using the expanded Construction Factor rules (see p. 121), the first level in the building hex being climbed that falls below the unit's tonnage (after damage) will collapse instead, and the unit's falling distance will equal whatever height it managed to ascend to before the level's CF gave out. (For example, a 35-ton 'Mech scaling a 7-level, CF-40 standard-class building would inflict 4 points of damage to the CF of each level as it climbs up the structure. This reduces the CF to 36 points at each level of the building's hex—still enough to support the 'Mech's weight. If, however, the sixth level suffered 2 points of CF damage at Level 6—likely from a stray SRM or machine gun burst—the climbing unit would collapse the sixth level upon reaching it because the CF there—already reduced to 38 points—would be reduced to 34 points by the 'Mech's tonnage, and would no longer be able to hold up the 'Mech. As the level collapses, the 'Mech would suffer a 6-level fall as well.)

#### Small Buildings

Small buildings are any structure standing 2 levels or less above the underlying terrain. Standard movement rules permit other units to ascend to the tops of these buildings as a consequence of a basic elevation-change movement. However, under these advanced rules, ground vehicles and 'Mechs may not simply drive or walk onto a building in this fashion. Instead, a suitable unit must climb per the Climbing Buildings rules above.

The above does not apply if a special bridge or road (representing a ramp) specifically links the building's upper level(s) with the unit's current level. In this case, such a climb would follow the standard rules for changing elevations while moving along a road.



Crimson Hawk, *Tau Provisional Galaxy* (*Gan Blood Spirit*)



## Advanced Building Features

With advanced building construction, units moving through a building hex may encounter a variety of additional obstacles not generally tracked in standard game play, such as low ceilings, internal equipment, heavy metal superstructure and so forth. These advanced building features can add to (or reduce) a non-infantry unit's mobility and susceptibility to suffering damage as it enters each building hex.

To determine the effect of any relevant advanced building features, consult the Advanced Building Movement Table below. Any applicable Piloting Skill modifiers are applied to the target number for all non-infantry Piloting Skill Rolls made to avoid taking damage from the building, in addition to those for the building's class and type on the Building Classifications and Types Table (see p. 115). Any applicable MP costs per hex are likewise added to the MP costs for the appropriate building class and type. The notes for each building feature then describe any additional effects on movement or combat within buildings that have such features. If multiple features apply to the same building hex, all modifiers presented here are cumulative, along with those for the building class and type.

*While brawling their way through a city, Jason and Rich find their two BattleMechs—a War Dog and a Warhammer, respectively—isolated in a built-up area on a map of their own creation. To escape their pursuers, the two warriors decide to split up and tear straight through the buildings nearby.*

*Jason's War Dog, as it happens, is facing a 3-hex long Medium standard building with a CF of 40, low ceilings and a heavy metal superstructure. A general-use building, it has been designed by the gamemaster to house unspecified equipment. Looking at the Building Classifications Table and the Advanced Building Movement Table, Jason finds that each hex of this building will cost his 'Mech 5 MP to move through (1 [Base MP cost per hex] + 2 [Medium Standard Building] + 1 [Low Ceilings] + 0 [Unspecified Equipment] + 1 [Heavy Metal Superstructure] = 5). He also finds that the Piloting Skill target number to avoid damage when charging through each building hex will have a +4 modifier (+1 [Medium Standard Building] + 1 [Low Ceilings] + 0 [Unspecified Equipment] + 2 [Heavy Metal Superstructure] = +4). As he has a Piloting Skill of 5, this means Jason will need to roll a 9 or higher for every building hex he plows through on his way to the other side or he will suffer damage from the building (and because his 'Mech has a Walking rate of 4 MP and a Running rate of 6 MP, moving through each hex will force Jason to run).*

*As Jason charges through his building, he looks at the notes on the Advanced Buildings Table and finds that each building hex he plows into will suffer 15 points of damage from his 75-ton War Dog thanks to the low ceilings (75 tons ÷ 10 [standard damage] x 2 [Low Ceilings] = 15). He further finds that if he fails his Piloting Skill Roll, his 'Mech will suffer a total of 16 damage points in the bargain, thanks to the low ceilings and heavy metal superstructure (CF 40 ÷ 10 [standard damage] x 2 [Low Ceilings] x 2 [Heavy Metal Superstructure]). Jason forges onward just the same, and narrowly makes his Piloting Skill Roll with a result of 9. The*

*building hex he enters sustains 15 points of damage, while his War Dog is unscathed.*

*Rich, meanwhile, finds that his Warhammer must crash through the walls of a Heavy hangar building 2 hexes long and 2 levels high—tall enough to accommodate his 'Mech. The hangar is built using standard construction, has a generator unit in the second hex, and unspecified equipment in the first hex. Consulting the tables, Rich finds that the movement through the hex with unspecified equipment will cost 2 MP (1 [Base hex cost] + 2 [entering Heavy Hangar] – 1 [Hangar hex with equipment] + 0 [Unspecified Equipment] = 2), with a –2 Piloting Skill modifier to avoid damage (+1 [entering Heavy Hangar] – 3 [Hangar hex with equipment] + 0 [Unspecified Equipment] = –2), and the hex with the generator will cost 2 MP (1 [Base hex cost] – 1 [Hangar hex with equipment] + 2 [Generator Equipment] = 2) with a –1 Piloting Skill modifier to avoid damage (–3 [Hangar hex] + 2 [Generator Equipment] = –1). The MP costs and Piloting Skill modifiers for a Heavy hangar do not apply, because Rich's 'Mech is already inside the building at this point, and the building has enough height to accommodate its size.*

*At a walk, Rich's 'Mech can traverse both of the building's hexes, but he must make a Piloting Skill Roll to avoid damage for each hex (though, if the second hex had been an empty hangar hex, no roll would have been needed). He decides to do so, confident in his MechWarrior's Piloting Skill of 4. For the first hex, Rich finds that his 70-ton Warhammer will automatically inflict a standard 7 points of damage to the building's 45 CF (because it is entering the building through a wall). With a Piloting Skill Roll result of 6 (easily beating his Target Number of 2 for the first hex [4 – 2 (first Hangar hex Piloting Skill modifier) = 2]), Rich's 'Mech receives no damage. He then moves onward, entering the generator's hex. Here, he makes a Piloting Skill Roll of 2, missing his Target Number of 3 to avoid damaging either himself or the building (4 – 1 [generator hex Piloting Skill Roll modifier] = 3). Because of this failed roll, Rich's 'Mech will inflict 7 points of damage to this building hex, and also receives 5 points of damage (CF 45 ÷ 10 = 4.5, rounded up to 5), applied randomly to the Front Hit Location Table.*

*Much to Jason's surprise, an enemy infantry platoon is present in his building, 2 hexes ahead. In addition to the +2 modifier to attack this platoon (or for the platoon to attack Jason's 'Mech) thanks to the standard rules for combat within buildings (see p. 175, TW), Jason notes that the presence of the unspecified equipment in each hex raises that to a +4 modifier. With a Gunnery Skill of 4, and having run to enter his hex, Jason's War Dog would need an 11 or higher to hit with its Gauss rifle (4 [Gunnery] + 4 [2 Building hexes, plus 2 Unspecified Equipment hexes] + 2 [War Dog's run] + 1 [Gauss rifle minimum range modifier] = 11), while his Streak SRMs (lacking the minimum range modifier) would need a 10, and his Large and Medium pulse lasers (which benefit from a –2 pulse laser modifier) would need 8 each. The regular-rated Rifle (Ballistic) infantry platoon with its Gunnery Skill of 4, by comparison, would need a 10 to shoot back (4 [Gunnery] + 2 [Medium Range] + 4 [2 Building hexes, plus 2 Unspecified Equipment hexes]).*

INTRODUCTION

ADVANCED  
GROUND MOVEMENT

ADVANCED  
COMBAT

ADVANCED  
BUILDINGS

ADVANCED  
SUPPORT  
VEHICLES

GENERAL  
RULES

ADVANCED  
SUPPORT VEHICLE  
CONSTRUCTION

ADVANCED  
WEAPONS  
AND EQUIPMENT

INDEX

RECORD SHEETS



## ADVANCED BUILDING MOVEMENT TABLE

Building Features	MP Cost/Hex*	Piloting Modifier**	Notes
Empty Hangar/Tunnel/Open-Space Hex	1	NA	Treat as Paved Terrain†
Hangar/Tunnel/Empty Cargo Hex	-1	-3	To a Minimum MP cost per hex of 1††
Non-Liquid Cargo Hex	+0	-2	
Liquid Cargo Hex	+1	+2	See <i>Liquid Fuel/Chemical Storage Tanks</i> (p. 134)
High Ceilings	+0	-1	Half all damage from movement (round down)‡
Low Ceilings	+1	+1	Double all damage from movement (round up)‡
Unspecified Equipment Hex‡‡	+0	+0	+1 to-hit modifier for weapon attacks (per hex)
Specified Equipment Hex‡‡	+1	+1	+2 to-hit modifier for weapon attacks (per hex)
Generator/Weapon Hex‡‡	+2	+2	+2 to-hit modifier for weapon attacks (per hex)
Heavy Metal Superstructure	+1	+2	Double damage to unit from failed Piloting Skill

\*In addition to all other applicable MP costs for the building type (see *Building Classification and Type Table*, p. 115)

\*\*In addition to all other applicable modifiers for the building type (see *Building Classification and Type Table*, p. 115)

†See *Open-Space Construction*, p. 138. Hangars and tunnels apply these rules only if they are as high as or taller than the moving unit, feature no equipment, and the unit is not moving through the building's outer walls (otherwise, apply the standard hangar MP and Piloting modifiers).

††Hangars and tunnels apply these costs and modifiers only if they are as high as or taller than the moving unit and feature interior equipment of any kind. (Do not apply normal hangar MP and Piloting costs if already inside.)

‡Applies to damage done both to the building and to the unit moving through it.

‡‡Do not count turreted or rooftop-based equipment.

### ADVANCED BUILDING CRITICAL DAMAGE

The basic rules for attacking buildings in *Total Warfare* treat buildings more as “destroyable terrain” than as complex systems in and of themselves. When dealing with less generic buildings (such as those that can be created using the rules in this section), the following additional rules enable players to reflect critical damage effects against such structures.

**Damage Threshold:** To use the Advanced Buildings Critical Hits rule, players must determine an advanced building's Damage Threshold at the start of any turn in which it suffers damage. This value is equal to the building hex's current Construction Factor (at the start of the turn), divided by 10 (round up). If the damage inflicted by any single weapon attack or Damage Value grouping exceeds the hex's Damage Threshold, the attacker must make a critical hit roll as outlined below.

**Armor:** Per Armored Buildings rules (see p. 121), critical hits may not occur against an advanced building hex that is armored as long as no damage is inflicted to the CF.

**Aimed Shots:** Against advanced buildings with level-specific equipment (such as turrets), an attacking unit may declare an aimed shot at the desired level and hex of the building where a targeted component is located. This attack works as a standard aimed shot against an immobile target (see p. 110, *TW*), striking the desired hex and level on a successful hit and a follow-up 2D6 roll of 6, 7 or 8. (If using the expanded Construction Factor rules [see p. 121], should this second roll fail, the damage is resolved against a random level of the same hex; otherwise, the damage is resolved against the hex normally.) A successful aimed shot adds a +2 modifier to the Advanced Building Critical Hit roll, as long as all other conditions for a critical hit apply (including exceeding the building's CF threshold).

Only units located outside a building, and with a valid line of sight to the desired building hex and level, can attempt an aimed shot against a building.

### Critical Hit Effects

The following rules describe the effects of critical hits against an advanced building. If the target hex (and level, if using the Expanded Construction Factor rules) does not contain an appropriate item corresponding to these critical effects, no critical hit occurs.

**Ammunition:** This result means the hex's ammunition explodes. Unlike a 'Mech, where only a single slot explodes, the hex loses all its ammunition. Count the total damage for all ammunition carried and apply the damage directly to the hex's Construction Factor. If CASE is mounted in a hex with an Ammunition critical hit, divide the total damage by 10 (round down) and apply that value to the hex's Construction Factor. As usual, ammo that cannot explode (such as Gauss and Plasma) is still destroyed and cannot be used for the rest of the scenario.

**Gunners Killed:** A critical hit kills or severely injures the gunners for this hex. No weapons can be fired from this hex for the rest of the scenario.

**Gunners Stunned:** Damage from the critical hit disorients the gunners. During the following turn, the hex may take no actions (firing weapons and so on). After that, the hex may act normally. Multiple Gunners Stunned results in the same turn extend the number of turns for which these effects last.

**Turret Jam:** The turret rotation mechanism temporarily freezes, leaving the turret stuck in its current facing until the gunners spend a Weapon Attack Phase fixing the jam. The hex may not fire any weapons from that turret (though other weapons in that hex may still fire) while the jam is being fixed. Treat a second or subsequent Turret Jam critical hit—regardless of whether the gunner cleared the first jam—like a Turret Locks critical hit.

**Turret Locks:** The turret rotation mechanism is severely damaged, locking the turret in its current facing for the remainder of the game. Additional critical hits of this type—or Turret Jam critical hits—have no further effect.



## ADVANCED BUILDING CRITICAL HITS TABLE

2D6 Roll	Effect
2–5	No Critical Hit
6	Weapon Malfunction
7	Gunners Stunned
8	Weapon Destroyed
9	Gunners Killed
10	Turret Jammed/Turret Locked*
11	Ammunition
12	Other

\*When rolling these critical hit results, roll 1D6. On a result of 1–3, the effect to the left of the slash occurs; on a 4–6 result, the effect to the right of the slash occurs.

**Weapon Destroyed:** One weapon mounted in the damaged hex suffers major damage and ceases to function. The attacking player then rolls 1D6. On a result of 1–3, the player controlling the target unit chooses which weapon stops working. On a 4–6, the attacking player chooses which weapon stops working. If there are weapons in and outside of a turret in a hex, randomly determine which location the player will choose from. The hex cannot fire that weapon for the remainder of the game. If a weapon is destroyed that can explode (such as a Gauss rifle), the weapon explodes for its normal effects as an equivalent-damage ammunition explosion for the location where the weapon is mounted (see *Ammunition*, p. 125, *TW*).

**Weapon Malfunction:** This critical hit causes a weapon mounted in the hex to malfunction. If a hex has multiple weapons in that location, randomly determine which one takes the hit using the Weapon Destroyed rule above. The hex cannot fire that weapon until the malfunction is fixed. The gunners must spend one Weapon Attack Phase clearing the malfunction, during which the hex may make no weapon attacks. The gunners may only fix one weapon malfunction per Weapon Attack Phase.

**Other:** A variety of other equipment can be mounted in an advanced building hex. On this critical hit result, a randomly determined item assigned to this hex (and level, if using the expanded Construction Factor rules; at right) is damaged and rendered inoperative. If no such other item exists in this location, this critical hit has no effect.

### ARMORED BUILDINGS

Some building classes—including fortresses, Castles Brian and walls—may be constructed with additional armor beyond their Construction Factor. If a building hex is armored, non-infantry units may not enter the hex except through an open (and suitably sized) large door (see *Large Doors*, p. 138).

Attacks against an armored building from outside the structure will not cause breaches, critical hits or CF damage until the armor in the targeted hex is destroyed. Attacks from inside an armored building will affect its CF directly, however.

### ATTACKING BUILDINGS FROM WITHIN

Though a dubious action in most instances, units inside a building hex may opt to deliver attacks against the building itself, rather than against any other units therein. This kind of attack automatically succeeds if the unit can trace a valid line of sight to the target hex and its weapons can reach that range (if using the optional LOS Range bracket—see p. 85—treat this as an attack against an immobile target at such ranges). A successful attack will deliver the weapon's full damage to the targeted building hex (and level, if using the Expanded Construction Factor rules); cluster weapons and weapons fired in rapid-fire modes deliver their maximum damage result.

If the attack is delivered using the standard building rules, the CF damage caused by such attacks affects the targeted hex as normal, regardless of whether the attacker aimed at a wall, the floor or the ceiling. If the expanded Construction Factor rules (below) are used, an attack against a building hex's floor or wall will affect the attacker's own level, while an attack against the ceiling will affect the CF of the level above the attacker.

If the attacked hex suffers damage significant enough to cause a collapse, and the attacking unit is within the same hex, it will suffer the effects of the resulting collapse per standard rules (see p. 176-177, *TW*), or—if they are being used—the expanded Construction Factor rules (below).

**Attacking Building Equipment:** If an advanced building employs specific equipment of any kind (see *Building Construction*, p. 128), and a unit inside the building can trace a valid line of sight and weapon range to it, the unit may opt to "attack" such equipment directly. Resolve this attack as an appropriate attack against an immobile target. A successful attack on such equipment will deliver the attack's damage to the equipment, rather than to the building's CF. To determine if the targeted equipment is destroyed, roll on the Advanced Building Critical Hits Table, at left, after delivering a successful attack, adding 10 percent of the attack's full damage value (rounded up) to the roll (so a standard Gauss rifle will raise a roll result by 2 points [ $15 \div 10 = 1.5$ , round up to 2]). If no other critical hit effect applies to the targeted item, a critical roll result of 10 will render the item inoperative, destroying the item if it occupies only one hex.

**Missed Shots:** It is virtually impossible to miss a building while standing inside it, especially when intentionally aiming at the structure or its components. If for any reason an attack against a building or building equipment fails to hit the targeted hex, deliver half the attacking weapon's rated damage (round up) against a randomly determined building hex adjacent to the targeted hex location. If no other potential target hex lies within the attacking unit's range or line of sight, deliver this damage to the target hex instead.

**Armored Buildings and Damage Scaling:** When attacking a building from within, any armor assigned to the building hex is ignored and damage is applied directly to the CF. However, if damage-scaling rules are in use, these rules continue to apply (see *Scaled Damage*, p. 126).

### CONSTRUCTION FACTOR (EXPANDED)

Under the standard *Classic BattleTech* rules presented in *Total Warfare*, the Construction Factor of a building is tracked per hex. This is done for simplicity and ease of tracking damage, particularly across numerous, large multi-hex buildings.

INTRODUCTION

ADVANCED  
GROUND MOVEMENT

ADVANCED  
COMBAT

ADVANCED  
BUILDINGS

ADVANCED  
SUPPORT  
VEHICLES

GENERAL  
RULES

ADVANCED  
SUPPORT VEHICLE  
CONSTRUCTION

ADVANCED  
WEAPONS  
AND EQUIPMENT

INDEX

RECORD SHEETS



Under the following Expanded Construction Factor rules, each level of each building hex tracks damage separately, using a CF at each level equal to that of the entire building. Thus, a four-level Medium building with a CF of 40 is treated as having a CF of 40 at each level, rather than over the entire structure.

**Armored Buildings:** As with CF, the armor on a building using Expanded Construction Factor rules also applies equally to each level (abstracting the manner in which building armor is effectively infused with the structure itself), so a building with a CF of 50 and 20 armor points under standard rules would receive 50 CF and 20 armor *per level* under these rules. If any armor remains on a targeted level, the CF for that level will not sustain damage and the hex may not be entered from outside (except via an open door).

**Area-Effect Weapons:** Under these rules, damage delivered by an attack from an area-effect weapon (see p. 173, *TW*) is determined for each level of a building whenever damage assigned to units is also assigned to those various building levels.

**Top-Down Collapse:** Under the Expanded Construction Factor rules, an entire building hex will not automatically collapse when a level within that hex has collapsed. Instead, any levels of structure *above* the destroyed level will fall into the structure and inflict additional damage to themselves and the building overall. This “top-down” collapse will inflict damage on the level above the originally destroyed level and the next level below it equal to one-third of the total CF of all the levels above the originally destroyed level (rounded down). If this damage exceeds the CF of either level, that level has been destroyed in the process and any excess damage transfers equally to the next level up (for the levels above the originally destroyed level), and down (for levels below the originally destroyed level). A top-down collapse will stop only if the falling upper levels are completely destroyed, or if they no longer inflict enough damage to destroy those below them. If floors remain to fall, however, players must re-compute their Damage Value after each level is destroyed.

A top-down collapse may also occur if the CF of any level of the building hex is reduced below the weight of any units occupying levels above the damaged level.

If the bottom-most level of a building hex is destroyed under these rules, the entire hex of the structure will collapse per the normal rules in *Total Warfare*.

**Total Collapse (Multi-Hex Buildings):** Under these rules, a multi-hex building will collapse if more than half its hexes suffer collapses that reduce them to half their original height or lower. (So a 6-hex building that started play at 4 levels in height will suffer a total collapse if 3 or more hexes of the building are reduced to a height of 2 levels or less.)

**Damage and Displacement:** All the standard rules (starting on p. 177, *TW*) apply. If a level collapses, falling damage and displacement are resolved normally.

When tracking damage per level, if a unit occupies a level that collapses, it will fall and deal damage to the level it strikes below, equal to the unit’s weight divided by 10 (round up, to a minimum of 1), multiplied by the number of levels it fell. As this is considered movement damage, damage is applied immediately to that level. A unit will not pass through a level it fell on unless the damage applied reduces the CF of that level below the weight of any units occupying that level, in which case the level collapses immediately, with the subsequent falling and displacement—and damage to the building—of those units immediately resolved.

Damage to units within a collapsing building is still resolved per the normal rules in *Total Warfare* (see pp. 176-178). To find

the damage, simply add up the CFs of all levels above the unit (not including the level the unit currently occupies) and divide that sum by 10 (rounding up). This damage applies in addition to normal falling damage, based on the difference in levels the unit has fallen. If any unit occupying an upper level finds itself falling into a lower level occupied by another unit, treat the effect as an accidental fall from above, resolved after all other damage from the collapsing levels is assessed, using both units’ original starting levels to determine the height of the fall.

*Randall and Herb are playing an urban battle in which the Expanded Construction Factor rules are in place. A 7-level tall advanced building has a CF of 50 and occupies 7 hexes on the map (hexes A through G). Inside, Randall has placed an infantry platoon that has spent several turns spotting for artillery fire against Herb’s forces (the platoon is in Hex C). Using the Expanded CF rule, the building began play with a CF of 50 for all 7 levels in each hex, but after several turns of combat, Hex C comes under fire when Herb realizes that Randall’s infantry platoon is somewhere inside. One of Herb’s attacks has delivered 10 points of damage to the third level (reducing its CF to 40), while another has inflicted 24 points of damage to the fourth level (reducing its CF to 26).*

*Frustrated after yet another artillery strike pummels his forces with deadly accuracy, Herb delivers another attack against the building’s fourth floor—using the Sniper Artillery Cannon mounted on his customized Zeus (located in Hex H. As a 10-point area-effect weapon with a damage radius into the adjacent hexes, the Sniper’s successful attack delivers three times its normal damage—30 points—to the fourth level of Hex C, as well as 20 points to the third and fifth levels of that hex, and 10 points to the second and sixth levels. Hex B of the three-hex building also sustains 20 points of damage to its fourth level, as well as 10 points of damage to its fifth and third level CFs. After assessing the damage, Randall finds that Hex C has now sustained a total of 10 points of damage to its sixth and second levels, 20 points of damage to its fifth level, 30 points of damage to its third level (10 from previous damage, 20 from the Sniper) and 54 to the fourth level (24 previous damage, 30 from the Sniper). As the damage on the fourth level exceeds the 50 CF of the building, that level of Hex C collapses.*

*Because the levels above and below the collapsed level still exist, the players find a top-down collapse has begun. To find the damage the collapsing upper levels (levels 5 through 7) will inflict, the remaining CFs of the upper levels are added together and divided by 3, rounding down. The result is 40 points ((50 points for Level 7) + [(50 - 10 = 40) points for Level 6] + [(50 - 20 = 30) points for Level 5]) = 120 ÷ 3 = 40). As the top-down collapse begins, Randall—as the building’s controlling player—applies 40 points of damage to the fifth and third levels. This damage destroys both levels, with the fifth level sustaining 60 points (20 points previously, plus 40 from the collapse), and the third sustaining 70 (30 from prior damage, plus 40 from collapse damage).*

*Excess damage from the fifth level’s destruction (10 points) transfers to the sixth level, bringing its total CF damage to 20, while 20 points of excess damage to the third level transfers down to the second, bringing it to a total CF damage of 30. Because upper floors still exist, the collapse continues—only now, the combined CF of the sixth and seventh levels comes to 80 (50 for Level 7, plus 30 for Level 6), for a collapsing damage value of 26 points (80 ÷ 3 = 26.667, rounded down to 26). After applying this damage to the levels above and below*

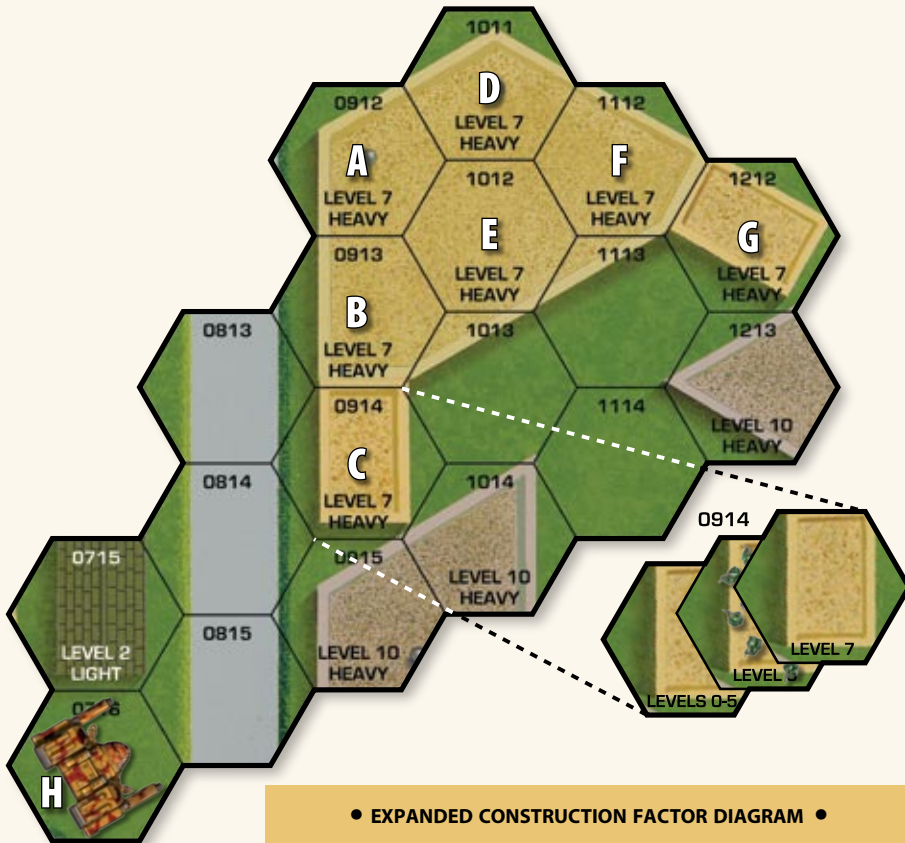

the destroyed levels—now the sixth and second levels—Randall finds that the second level has been destroyed with a total of 56 points of damage (30 previous points, plus 26 from this phase of the collapse = 56), but the sixth level still has some CF remaining (20 previous damage, plus 26 = 46). The 6 points left over from the second level's collapse transfer to the first level, and the collapse continues.

With a combined remaining CF of 54 (50 for Level 7 and 4 for Level 6), Randall finds that the falling levels now inflict only 18 points of damage in their continued collapse to levels 1 and 6. This will destroy Level 6's 4 remaining CF and transfer 14 points to Level 7's CF. Against Level 1, the 18 points adds to the 6 points from the last part of the collapse, leaving Level 1 intact with a CF of 28 ( $50 - [18 + 4] = 28$ ). Because the damage failed to collapse the lower floor, the top-down collapse of the building hex has ceased, leaving two battered but still technically intact levels remaining in Hex C—except that the seventh level has now fallen to Level 2, a five-level plunge.

Randall's foot infantry—who were on level 6 all this time—sustained only 25 percent damage from the collapse of their floor (a CF 50 standard building, as a Heavy Building, passes along only 25 percent of its damage to the infantry unit within—per p. 173, TW), for a total of 13 points ( $50 \times 0.25 = 12.5$ , round up to 13). In addition, they now face 9D6 damage for falling five levels (3D6 for every 2 levels—or fraction thereof—results in 9D6 damage, per p. 151, TW), plus 4 points for the collapse of Level 7 on top of them ( $36 \text{ CF} \div 10 = 3.6$ , round up to 4 points). The odds of any survivors from that catastrophe are slim."

## BUILDING COLLAPSE (EXPANDED)

Under the standard *Classic BattleTech* rules presented in *Total Warfare*, a collapsing building hex does not affect any other hex. However, particularly tall buildings, or multi-hex buildings, can cause heavy damage to the rest of the structure or throw out a lot of debris as they fall. To reflect this more accurately, the following rules provide a more extensive alternative to the standard building collapse rules.

### Multi-Hex Building Collapse

When a building hex that is part of a multi-hex building collapses, it automatically damages all adjacent building hexes in the same multi-hex building. To reflect this, when one hex of a multi-hex building collapses, reduce the current CF of every hex that is part of the same building and adjacent to the collapsing hex by half (rounding the result down). If multiple hexes adjacent to an affected hex of a multi-hex building collapse in the same damage phase, this halving effect applies only once.

**Scaled Damage:** This damage is modified if using the Scaled Damage rules (see p. 126).

**Construction Factor (Expanded):** If using the Construction Factor (Expanded) rules (see p. 121), when any level of a hex collapses, divide the damage for every level adjacent to the collapsing hex that is part of the same structure by half (rounding down). If the entire hex collapsed, divide every level in the adjacent and connected hexes by half (rounding down).

**Order of Damage:** All damage to adjacent and attached building hexes and/or levels applies after all collapsing, falling and displacement effects have occurred from the collapse of the original hex (or level, if using the Expanded Construction Factor rules). See *Collapse*, p. 176, TW, for rules on these additional effects.

### Building Collapse Splash Damage

A building hex that collapses also has a chance of spilling its debris into other hexes (even if it is not part of a multi-hex building). This "splash" damage depends mainly on the height of the collapsing building hex.

**Area of Effect:** The debris from a collapsing building will affect a radius equal to 1 hex for every 12 full levels in height that the building (or building hex) stood at the time of its collapse, rounded down. This means an 11-level tall building will not affect any adjacent hexes, while a 50-level skyscraper will affect a radius of 4 hexes if it topples ( $50 \div 12 = 4.1667$ , rounded down to 4). All units, buildings and terrain within the affected area—except for other hexes of the collapsing building itself—will receive area-effect damage from the collapsing building as described below unless a building hex or hill equal to or taller than half the collapsing building's height (rounded down) lies

INTRODUCTION

ADVANCED  
GROUND MOVEMENT

ADVANCED  
COMBAT

ADVANCED  
BUILDINGS

ADVANCED  
SUPPORT  
VEHICLES

GENERAL  
RULES

ADVANCED  
SUPPORT VEHICLE  
CONSTRUCTION

ADVANCED  
WEAPONS  
AND EQUIPMENT

INDEX

RECORD SHEETS



between the affected hex and the collapsing building hex. (If in doubt—such as if the line of sight follows a hexside where one half would block the debris and the other would not—assume the building receives the better “cover”.)

**Damage:** All splash damage—applied as an area-effect attack to any units or buildings in the affected hexes—is computed as follows:

- For all units in the adjacent hexes, divide the collapsing hex's CF (as it was at the beginning of the turn) by 20, then multiply that value by the number of levels the building hex stood. Round the result up to the nearest whole number.
- For every hex outward beyond the adjacent hexes, add 10 to the CF divider before multiplying for the number of collapsing levels. Thus, at 2 hexes from a collapsing building (if it is tall enough to affect those hexes), the collapsing hex's CF is divided by 30 (20 + 10), then multiplied by the building height. At 3 hexes, the CF is divided by 40 (20 + [10 x 2]), then multiplied by height. At 4 hexes, the CF is divided by 50 (20 + [10 x 3]) before multiplication, and so on.
- As this reflects the random and uncontrolled scattering of falling debris from a great height, partial cover does not protect against this type of splash damage.
- Units inside a collapsing building hex suffer damage as normal for a collapsing building, with no additional splash damage effects applied.
- The splash damage effect from a collapsing building will not only cause damage to all units and structures within the surrounding hexes, it will also fill such hexes with rubble and will also act as an unintended Clearing Woods action (see pp. 112-113, *TW*) if any woods or jungle terrain lies within the affected area.

### Scaled Damage

This damage is modified if using the Scaled Damage rules (see p. 126).

### Order of Damage

The collapse, falling and unit displacement effects of the original collapsing hex—as described under *Collapse* in *TW* (see p. 176)—are resolved first. Next, if the hex is part of a multi-hex building, damage to the adjacent building hexes, as noted under *Multi-hex Building Collapse* (see p. 123), is applied. Finally, the splash damage from a collapsing building hex is applied.

All affected hexes should be dealt with in this order, before any additional collapses are resolved. In other words, if a Level 13 multi-hex building hex collapses, and the damage from the collapse reduced the CF of an adjacent building hex to 0, that building collapse would not be resolved until the splash damage from the originally collapsing building hex is resolved.

### Domino Effect

If the splash damage from a collapsing building should cause another building hex to collapse, resolve that effect only after completely resolving the effects of the first collapse. If multiple buildings are collapsed in this fashion, pick the one that can deliver damage to the most nearby buildings and units in its area of effect (for example, a building with a splash radius of 2 hexes, within which are two other building hexes and a vehicle, would resolve its damage before another building that would only inflict damage on two infantry units).

*In the Building Collapse Splash Damage diagram at right, the players are running a game where the Expanded Building Collapse rules (but not the Expanded CF rules or Damage Scaling) are in effect. The 5-hex, 24-level Fortress-class high-rise sandwiched among other buildings in a massive skyscraper complex (represented by Hexes A through E), began play with a starting CF of 95, while the adjacent structures represented by Hexes F through I and J through M each began play with a CF of 75 and 120, respectively. The level 6 building represented by Hexes Q through S, and the level 2 building represented by Hexes T through X, each have a starting CF of 60.*

*By the third turn of game play, the high-rise—marked as a primary objective—has suffered 44 points of damage to Hex B (reducing it to a CF of 51). In the following turn, the Demolisher II in Hex N unloads its full fury—a double-fired Ultra-AC/20 and an LB 20-X using solid slug ammunition—against Hex A, while a second Demolisher II (in Hex O) unloads with the same volley. Scoring a full hit, the first Demolisher inflicts 60 points of damage, while its partner hits with only its LB and half the burst from its Ultra AC for another 40 points. This damage, however, is more than enough to completely collapse that building hex.*

*Because Hex A is part of a multi-hex structure—connected to the rest of the building by one hexside—the Multi-Hex Collapse rule applies first, and the adjacent building hex (Hex B) is reduced to half its current CF. As it was previously damaged, this reduces B to a CF of 25 ( $51 \div 2 = 25.5$ , round down to 25). The building's third through fifth hexes—Hexes C through E—remain unaffected, because they are not adjacent to the collapsing hex, and remain strong at a CF of 95 each. Though the building hexes G, I, and J are all adjacent to Hex A as well, they are treated as belonging to separate buildings because they have a different height and CF, thus they suffer no immediate damage from the Multi-Hex Collapse rule.*

*After assessing the immediate damage from the collapse of Hex A, the splash damage is assessed next. As Hex A stood 24 levels high, its debris will affect a radius of 2 hexes from the collapsing hex ( $24 \div 12 = 2$ ). In Hex A itself, the damage applied against any units will be as normal for units within or on top of a collapsing building (but none were in that hex to suffer such damage). For the adjacent hexes (not including Hex B—which is part of the same structure and already sustained its damage effects), the “splash” damage will equal 114 points ( $95 \text{ CF} \div 20 \times 24 \text{ Levels} = 114$ ). Within this radius lie building hexes G, I, and J, as well as light woods in hex P. As 114 points exceeds the Construction Factors for hexes G and I (but not J), these “destroyed” Building hexes will collapse, while the light woods terrain (hex P) will become a rough hex, as its Terrain Factor of 90 is also exceeded by hex A's splash damage. Hex J, which had been previously undamaged, is reduced from a CF of 120 to a CF of 6 ( $120 - 114 = 6$ ).*

*At 2 hexes distant, the splash damage from Hex A's collapse will be 76 points ( $95 \text{ CF} \div 30 \times 24 \text{ Levels} = 76$ ). This will be resolved against the front facing of the Demolisher II in hex N, but will not affect the building hexes F, H, K, L or T because Buildings at least half as tall as Hex A's 24 levels block the line of sight (even though hexes G and I are in the process of collapsing themselves). The Spider standing on the level 6 building in hex Q is also unaffected despite being in the radius of Hex A's splash damage, because Hexes B and I are blocking debris from falling into that area. Thus, the only damage delivered to anything 2 hexes away from Hex A is the damage to the Demolisher II in*

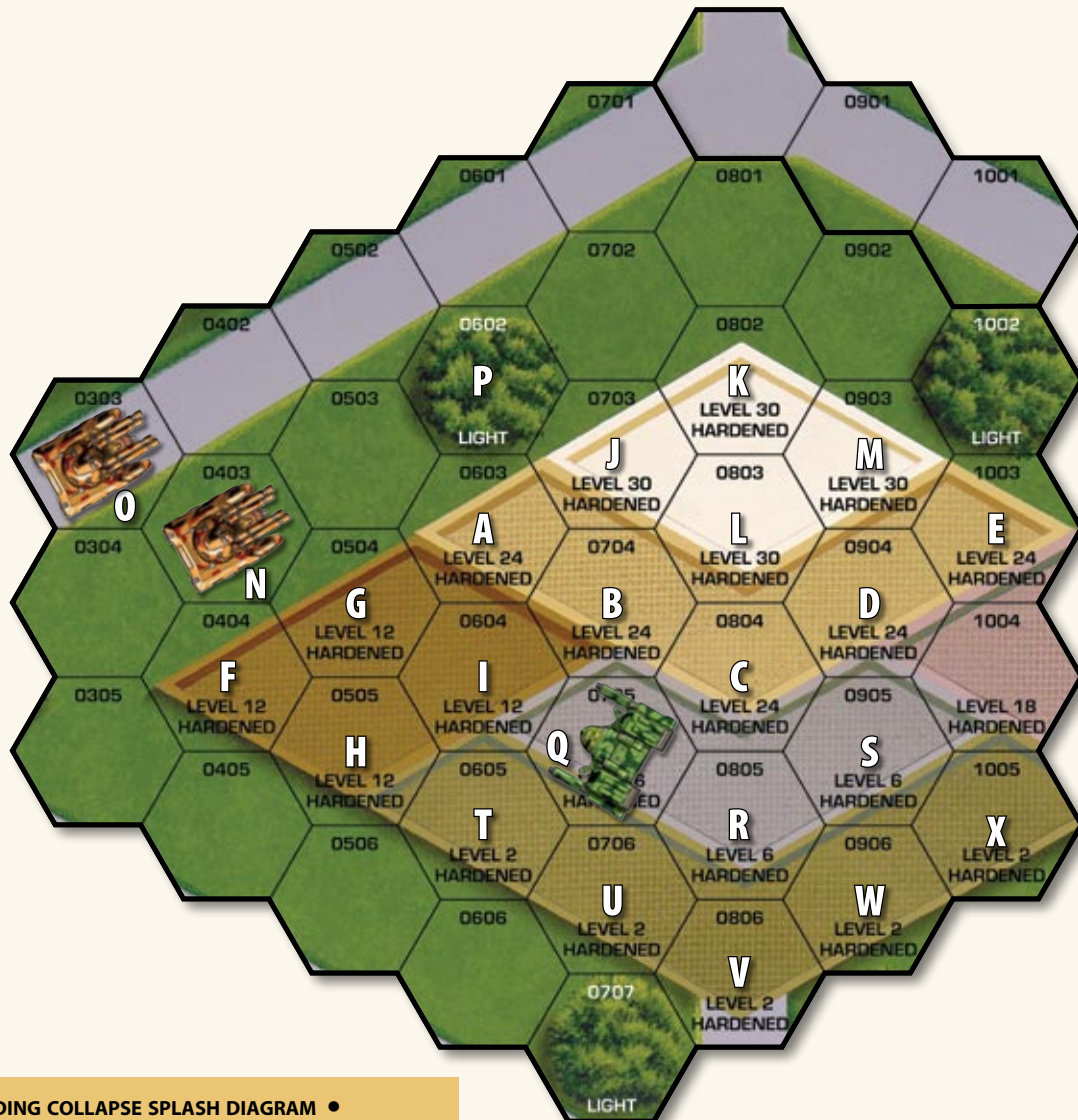

• BUILDING COLLAPSE SPLASH DIAGRAM •

Hex N. Finally, the entire area within 2 hexes of Hex A (that is not blocked from debris by other structures 12+ levels in height) is filled with rubble.

Now that the collapse of Hex A is completely resolved, the players note that Hexes G and I have also collapsed in the process. As both represent parts of the same 4-hex building—which started the game at a CF of 75 and stood 12 levels tall—the Multi-Hex Collapse rule applies, reducing the remaining 2 hexes of the same building (Hexes F and H) to half their current CF. Since neither hex suffered previous damage, this will leave them reduced to 37 ( $75 \div 2 = 37.5$ , round down to 37). While Hex H was adjacent to two collapsing hexes of the same structure, it applies the halving effect only once.

Although they are adjacent to Hex I, Hexes B, Q, and T represent different buildings, and so the Multi-Hex Collapse rule does not affect them.

The splash damage for Hexes G and I are assessed next. As both stood 12 levels high, the area of effect for each of

these buildings' splash damage will be 1 hex ( $12 \text{ levels} \div 12 = 1$ ). For Hex G, this means that the Demolisher in hex N will once more be affected by falling debris, but no other units or building hexes not already destroyed (like Hex A) or part of the same multi-hex structure (like Hexes F and H) will suffer additional damage. For Hex I, this damage will affect the building hexes B, Q, and T, as well as the Spider on hex Q's rooftop (because while it stands on a building that could block the debris, the building does not lie between the Spider and the collapsing hex I).

The splash damage caused by the collapsing hexes G and I comes to 45 points. The Demolisher II—affected by Hex G's splash damage—thus suffers another 45 points of damage, resolved against its right side facing. Hexes B, Q, and T—affected by Hex I's collapse—will suffer 45 points each, as will the Spider atop Hex Q. This reduces Hex B (already reduced to 25 by Hex A's collapse) below a CF of 0 (starting another collapse), while hexes Q and T survive with a final CF of 15 points each ( $60 - 45 = 15$ ). If the Spider

INTRODUCTION

ADVANCED  
GROUND MOVEMENT

ADVANCED  
COMBAT

ADVANCED  
BUILDINGS

ADVANCED  
SUPPORT  
VEHICLES

GENERAL  
RULES

ADVANCED  
SUPPORT VEHICLE  
CONSTRUCTION

ADVANCED  
WEAPONS  
AND EQUIPMENT

INDEX

RECORD SHEETS



is not destroyed after resolving the 45 points applied to its left side arc (where Hex I's damage originates from), its 35-ton mass will cause Hex Q to collapse as well.

Because the damage from hex I's collapse has done it in, hex B crumbles the same way hex A did, halving the CF of hex C in the bargain (to 47 points;  $95 \div 2 = 47.5$ , round down to 47) thanks to the Multi-hex Collapse rule, and dishing out 114 points of damage to all structures and units within 1 hex, and 76 points to all structures and units 2 hexes away—as was computed above when hex A collapsed to start with.

Hex J—already reduced to just 6 points when hex A fell, is collapsed as a result of this, while hex L is reduced to 6 CF ( $120 \text{ CF} - 114 = 6 \text{ CF}$ ). Hex C is unaffected because it is part of hex B's building, but hex Q and the Spider (if they weren't already going down from prior damage and the Mech's weight) are pounded by 114 points as well—enough to wipe out the building segment in hex Q, if not the already-damaged Spider. (If, by some miracle, the Spider survived all that, it still has a 6-level fall to contend with, thanks to its position when this disaster began.)

At 2 hexes from hex B, 76 damage points then rains down, leaving hexes K and M alone because of the presence of hexes J and L, and leaving R unscathed because the line of sight between hexes B and R passes alongside hex C—which deflects the debris. But hexes H, T, and U are not spared. As hex H is already reduced to 37 from hex I's collapse, and hex T was reduced to 15 by hex I's splash damage, and hex U has a CF of 60, all three hexes collapse from hex B's splash damage.

With this fourth round of collapsing building hexes, the players find that hex F—already reduced to a CF of 37 when hex G collapsed—now suffers another CF reduction from hex H's collapse. Hex H's splash damage—effective as computed above for G and I at 45 points—will not add to this misery, and lack any targets to affect, so they will simply fill all other adjacent hexes with rubble. Although this would technically leave hex F teetering at a CF of 18 ( $37 \div 2 = 18.5$ , round down to 18), this hex will now collapse because, at this point, over half of its parent multi-hex building has been destroyed.

Hexes Q and U, meanwhile, will reduce hexes R and V (respectively) to 30 CF as a result of their falls thanks to the Multi-Hex Collapse rule, but inflict no splash damage at all because they are too short.

Hex J, finally, will halve the current CF values for hexes K and L (to 60 and 3, respectively) as a result of the Multi-Hex Building Collapse rule, but will not affect any other buildings with splash damage, despite a 2-hex area of effect ( $30 \text{ levels} \div 12 = 2.5$ , round down to 2), because hexes K and L are deflecting its debris. However, as a 30-level tall building with a starting CF of 120, its splash damage would have been most devastating, with 180 points to all adjacent hexes and 120 to all units and buildings 2 hexes away. With no other units or buildings to damage, however, the debris simply fills all its affected hexes, creating Rubble terrain for the next turn.

And thus, the final building hex to collapse from the two Demolisher IIs' fateful volley is none other than Hex F, which delivers another 45 points in splash damage to all adjacent hexes. The tank in Hex N, which already suffered 76 points to the front arc from the fall of hex A, and 45 from the collapse of hex G to its right side arc, will be lucky if it survives another 45 to its side as Hex F falls. However, as its single blast has helped down 10 hexes of buildings and a Spider in a spectacular cloud of debris, the controlling player may see this as a fair trade.

## SCALED DAMAGE

Under standard *Total Warfare* rules, damage applies equally to all building types. In reality, however, not all buildings are created equal. Beyond simple Construction Factor values, the very nature of the building and its architecture can change the way in which it handles damage and protects units within it. For example, hangars are much less effective at shielding units inside them than standard buildings, while fortifications are specifically designed to reduce the effects of weapons fire all around.

The Damage Scaling column of the Buildings Classification and Type Table (see p. 115) details the scaling of damage depending on the classification of a building. The information to the left of the slash indicates how the damage is modified when it is applied to the building hex (or a unit inside the building hex) after the players have determined how much damage the building hex will absorb (see *Attacking Units Inside Buildings*, p. 171, *TW*). The information to the right of the slash indicates how damage is modified when applied to a unit that is entering the building hex in any fashion other than through an open door (such as a failed roll to avoid damage while entering a building hex, or skidding into the building, and so on).

In both cases, the information is expressed as either a multiplier ( $\times 0.5$ ,  $\times 1$  or  $\times 2$ ) or—as in the case of a Castles Brian—with the word “Capital”. These values work in the following manner.

Multipliers on the left side of the slash modify the amount of damage that the building (and any units therein) will sustain if hit by a successful attack (with any fractions rounded down). For example, if a value of  $\times 0.5$  appears here (as in the case of a gun emplacement or fortress), the damage delivered to the building and its occupants by any attack will be multiplied by 0.5, reducing the attack's effectiveness by half.

Multipliers on the right side of the slash reflect the amount of damage inflicted on any units by the structure, such as when crashing through its walls, colliding after a skid or suffering through the building's collapse. For example, if a value of  $\times 2$  appears here, a unit crashing through the walls of this structure will multiply any damage taken by 2.

A value of “Capital” on either side indicates that the structure uses capital-scale damage, as noted in *Total Warfare* under *Scale* (see p. 238, *TW*). When dealing damage to a building hex that has a “Capital” damage scaling value, total all the damage from a single unit's attacks (taken separately for the Weapon and Physical attack phases)—or the damage directed against the building from crashing through its walls—and divide by 10 (round normally; .5 rounds up). This new Damage Value is applied to the building hex's CF. In addition, when attempting to apply damage from such an attack against units inside a building with Capital damage scaling, determine the hex's current Damage Threshold by dividing its current CF by 10 (rounding up). If a single hit exceeds the structure's current Damage Threshold (regardless of by how much the damage exceeds it), the attack will deliver a single 10-point, standard-scale hit to all units inside (assigned in 5-point Damage Value groupings; treat as an area-effect weapon for infantry). When applying damage to a unit (or other buildings) from a building with Capital damage scaling (such as through movement, building collapse and so on), the resulting Damage Value must be multiplied by 10 before it can be applied as appropriate.

Note that damage scaling applies across the board, whether the damage is dealt to the building through movement, combat or planetary conditions. The damage from a collapsing building



is also scaled when applied to other units and/or building hexes (see *Multi-hex Building Collapse* and *Building Collapse Splash Damage*, p. 123, respectively). In all cases, after scaling, round down.

*Peter is trying to determine which of two targets his TI-2P Titan II will fire on. Enemy BattleMechs are in two different building hexes: a 38 CF fortress and a 38 CF Castles Brian.*

*The Titan has line of sight to each building hex, and the levels on them containing the enemy units. With both structures standing less than 3 hexes away, Peter's 'Mech is at short range to each building hex. Since they are immobile structures, he knows that all his weaponry will automatically hit, and so he tosses heat concerns to the wind and fires everything: Heavy PPC, four ER Medium Lasers, a Streak SRM-6 and two MML-9s (even though he's in the minimum range for the LRMs, Peter knows he's got no chance to damage the units inside the building if he loads the MMLs with SRMs, so he's firing LRMs; the -4 immobile modifier negates the minimum range modifier, making even these shots a sure thing).*

*Peter decides to run quick numbers to determine which attack will be the most effective against the targets (he assumes he'll roll an average of 7 on the Cluster Hits Table for his MML-9s, giving him 5 missiles for each—which would be divided into 5-point Damage Value groupings).*

*Looking at the Attacking Units Inside Buildings rules (see p. 171, TW), Peter determines that each building will absorb 4 points of damage from each attack ( $38 \div 10 = 3.8$ , rounded up to 4) against the units within. This will leave the following Damage Values to strike the 'Mech targets inside a building hex: 11 points for the Heavy PPC ( $15 - 4 = 11$ ); 1 point for each ER Medium Laser and each 5-point grouping from his MML-9s ( $5 - 4 = 1$ ); no damage from each SRM (as the 2-point Damage Value groupings would be reduced below 1).*

*Consulting the Buildings Classification and Type Table, Peter next assesses how the damage will scale against each building.*

*For the fortress, Peter sees a Damage Scaling Multiplier of 0.5 to the left of the slash, meaning that the damage is halved (rounded down) for attacks against the building and any units inside it. Thus, against the 'Mech inside the fortress, the Titan's Heavy PPCs will find their 11-point hits further reduced to 5 ( $11 \div 2 = 5.5$ , rounded down to 5), while the 1-point hits from the ER Medium Lasers and twin MMLs will be reduced to 0 damage ( $1 \div 2 = 0.5$ , rounded down to 0). Against the fortress hex itself, however, the following damage applies: 7 points from the Heavy PPC ( $15 \div 2 = 7.5$ , rounded down to 7), 2 points of damage for the four ER Medium Lasers and the 5-point missile groups from the twin MMLs ( $5 \div 2 = 2.5$ , rounded down to 2), and 1 point of damage for each SRM missile ( $2 \div 2 = 1$ ). Such an attack would thus reduce the fortress' CF from 38 to 13 ( $38 - [7 \text{ PPC} + (4 \times 2) \text{ ER Medium Lasers} + (2 \times 2) \text{ MML-9s} + (6 \times 1) \text{ Streak SRM-6}] = 13$ ). If this had been a building with x1 scaling damage, the damage would have been twice as severe, and would have reduced the fortress to rubble.*

*For the Castles Brian, Peter notes that damage now falls into capital-scale rules. Peter first totals up all the weapons damage from his Titan II, which comes to 57 points [ $15$  (Heavy PPC),  $+ 20$  ( $4 \times$  ERML)  $+ 10$  ( $2 \times$  MML),  $+ 12$  (Streak SRM)  $= 57$ ]. He then divides that value by 10, leaving him 6 points of capital-scale damage ( $57 \div 10 = 5.7$ , rounding up to 6) to apply to the Castles Brian's CF, reducing it from 38 to 32. Next, Peter checks to see if any damage will actually pass on to the 'Mech target inside. He first determines the current Damage Threshold of the Castles Brian to be 4 points ( $38 \div 10 = 3.8$ , rounding up to 4), and then compares that to damage from each individual weapon hit, to see if any can inflict capital-scale damage greater than 4 points. Peter quickly notes that nothing his Titan carries even comes close (the Heavy PPC only inflicts 1.5 capital-scale damage points). This means no damage will be passed on to the 'Mech inside the Castles Brian.*

*Peter's obvious choice is thus to fire on the fortress hex, hoping that some artillery or bombing runs will make quicker work of the Castles Brian than he can with his Titan II.*



Constant pirate raids have reduced a once thriving Periphery city to ruins.

INTRODUCTION

ADVANCED  
GROUND MOVEMENT

ADVANCED  
COMBAT

ADVANCED  
BUILDINGS

ADVANCED  
SUPPORT  
VEHICLES

GENERAL  
RULES

ADVANCED  
SUPPORT VEHICLE  
CONSTRUCTION

ADVANCED  
WEAPONS  
AND EQUIPMENT

INDEX

RECORD SHEETS



# BUILDING CONSTRUCTION

Even under the advanced rules discussed above, the various building classifications and types reflect “generic” structures. In truth, buildings can be outfitted with a variety of additional components (elevators, armor, weapons and so on) that can also have a direct effect on game play. The basic rules below cover these details by enabling players to construct custom buildings for game play.

## Pre-Generated Maps

All buildings on pre-printed maps published by Catalyst Game Labs (or FanPro/FASA) represent generic structures, which can use the *Total Warfare* rules, as well as the advanced rules discussed above. In terms of the construction rules outlined below, these buildings stop at the end of Step 1 (see *Step 1: Establish the Superstructure*, at right), which is a valid point for any players to stop at in the design process, and allows for game play without too much additional complexity.

Players can add variety to these pre-generated buildings simply by picking up the process where the maps left off, adding extra features such as armor and equipment to the building designs, or modifying what is shown on the mapsheet into a more sophisticated “look-alike”—perhaps by reclassifying one or two Hardened buildings as a Castles Brian. The size and shape of the building wouldn’t change on the map, but the Construction Factor could be modified, as well as the way damage is inflicted.

## Static Buildings vs. Mobile Structures

The buildings covered in this section share much with Mobile Structures in terms of overall design and functions, with the only major difference between them being the fact that static buildings are not mobile, and thus do not have to invest internal capacity in power and motive structures. In addition, the more permanent nature of static buildings allows for a broader range of design options and sizes, including subsurface buildings and Castles Brian (which cannot be built as Mobile Structures).

To cut down on redundancy, these rules refer to the Mobile Structure design rules where they most directly apply (such as when mounting armor, heat sinks and weapons).

## BUILDING BASICS

Building construction relies on three primary factors: technology base, building classification and Construction Factor.

### Technology Base

In standard-rules play, as with units, Clan buildings can only mount Clan equipment while Inner Sphere buildings can only mount Inner Sphere equipment. If using the Mixed-Technology Rules (see p. 377), then an advanced building can mount both.

**Tech Rating:** All weapons and equipment (whether found here or in *TechManual*) receive a Technology Rating in addition to a technology base. This rating (expressed as a series of letter grades that indicate the level of technology and its availability through the major eras of *Classic BattleTech* history) helps to define the item’s level of sophistication and can be used for era-based campaigning. Beyond this, however, an item’s Technology Rating has no direct bearing on building design.

### Building Classification

An advanced building’s ability to mount additional components is dependent on its building classification. These rules are discussed under *Install Components* (see p. 131).

### Construction Factor (CF)

Once a player has verified that a building classification can mount a component, the Construction Factor (CF) then must be taken into consideration to determine if the building type can mount that component—or, if it can mount such equipment, how much tonnage it may mount.

### Complexes

Complexes are groups of buildings that collectively serve a combined function. Most—but not all—may be buildings of similar or even identical types, such as a warehouse complex, a military base or an industrial park. Designers wishing to build such complexes need only generate multiple buildings.

## THE DESIGN PROCESS

The following basic rules cover the construction of advanced buildings. Despite their range of types, sizes and capabilities, these structures follow five simple design steps, each of which is described in detail later. In brief, these steps are as follows.

**Step 1:** Establish Superstructure—Determine the building’s technology base, classification, structure type, size and Construction Factor (CF).

**Step 2:** Install Armor—Determine type, amount and weight of armor (if any), and add armor points.

**Step 3:** Install Weapons, Heat Sinks, Equipment and Control Systems—Add weapons, any required heat sinks and other equipment to the advanced unit, as well as facilities for crews as needed.

**Step 4:** Complete the Record Sheet.

The above steps are a framework for designing an advanced building. The actual process can involve a bit more flexibility as equipment and armor (if any) are balanced for their best fit in terms of tonnage and space. For example, some designers might wish to assign armor before the weapons and heat sinks are established, to maximize protection over firepower. Others may want to add equipment first, leaving any remaining tonnage to armor and other modifications.

To assist in this effort, the designer may find it useful to make copies of the Structure Record Sheet (in the back of this book), to visually arrange the placement of weapons and equipment while tracking the use of weight on a piece of scratch paper.

**Terminology:** Buildings, like Mobile Structures (see *Designing Mobile Structures*, p. 259), are not constructed so much by a weight standard, though their design does use weight as a regulating factor when it comes to equipment capacities. Thus, classifications and Construction Factors are used to determine the broader capabilities of each structure type.

## STEP 1: ESTABLISH SUPERSTRUCTURE

The first step in creating an advanced building is choosing its primary function, size, height and framework. This step determines some of the most basic aspects of the building, including its classification, its technology base, its size and its CF. These choices will restrict the designer’s access to certain equipment and can also influence the building’s capabilities in game play.



### Choose Technology Base

Buildings may be constructed using Clan or Inner Sphere technology bases.

### Choose Building Classification

When choosing a classification, the designer must first determine what kind of building he wishes to construct: house, skyscraper, warehouse, office building, military barracks and so on. Often a player will already have a specific image in mind, perhaps of a “real world” building.

With that image in mind, the designer must then consult the *Advanced Building Classifications* section (see p. 114) to find the classification that best fits the building’s chosen function.

### Choose Building Type

The building type—Light, Medium, Heavy or Hardened—helps determine the range of Construction Factor (CF) values available to the structure design. The type also determines other factors, such as the MP costs and Piloting Skill Roll modifier that apply to units entering each of the building’s hexes. As shown in the Building Classifications and Type Table (see p. 115), not all building types are available for all building classifications.

### Choose Construction Factor

A building’s Construction Factor (CF) is used in several ways during the design process as well as during game play. This value reflects not only the maximum amount of damage each hex of the structure can withstand before collapsing, but also the maximum weight of any units occupying each hex.

In construction, CF is also used to determine the weight capacity of any equipment mounted in the building (per level). If a given building classification allows the designer to mount a desired component, the Construction Factor determines whether that component can fit within the design.

The range of CFs available to a given building classification and type is shown on the Building Classification and Type Table (see p. 115).

**Internal Weight Capacity:** For each hex of area covered, all advanced buildings—except for tents, hangars, fences and bridges—may internally carry a total tonnage of equipment (including weapons, heat sinks and armor) equal to their Construction Factor times the number of levels of structure height. Because of their open frames, hangar-type structures may triple this capacity, but that same open frame means they can support a maximum of 600 tons of equipment per hex for every 4 levels of structural height (or fraction thereof), even if their structural tonnage capacity would support more. Tents, fences and bridges have no internal weight capacity for equipment, but bridge hexes may support external weight (on top of the bridge) in the same fashion as a building of equivalent CF.

**Castles Brian:** Buildings with a Castles Brian classification use a capital-scale CF rather than standard-scale. As with armor, each point of capital-scale CF translates to 10 points of standard-scale CF damage, as well as 10 tons’ worth of structural support for units in a Castles Brian structure. Each point of a Castles Brian’s CF also translates to 10 tons’ worth of per-hex internal weight capacity (per level).

### Choose Size and Shape

The final part of this step determines the building’s size and shape—how many hexes it covers, how many levels each hex contains and how it fits on the mapsheet. The Building Classification and Type Table (see p. 115) lists the maximum total number of hexes for each building classification and building type. Within this range, a designer may arrange the hexes in any shape desired, but for ease of design, every hex of a given building receives the same level in height.

**Walls/Fences:** These special buildings have no set maximum limit for length, but do have a maximum effective height allowance, depending on their classification and type. Walls and fences also effectively occupy only the sides of a hex, not an entire hex. For purposes of these rules, any continuous length of wall or fence must be treated as a single building, and thus receives the same technology base, type, CF and height.

**Bridges:** Like walls and fences, these special building types have no set maximum limit for length, and no effective height (as the main portion is effectively treated as a special form of road), but all such structures must begin and end on the same level of terrain (with no higher terrain levels in between). Like walls and fences, these special building types have no set maximum limit for length, and no effective height (as the main portion is effectively treated as a special form of road or rail, as desired), but all such structures must begin and end on the same level of terrain (with no higher terrain levels in between).

### Complexes

Complexes, which are represented as a group of multiple buildings in close proximity or directly connected, are constructed as multiple separate buildings. Each building in a complex may thus be built using a different building classification, type, CF, size and shape. As they are part of the same overall construction project, however, complexes may not vary by technology base.

**Castles Brian:** Castles Brian, a unique form of building complex, are almost always far more sophisticated than a simple arrangement of multiple buildings. For more information on these complexes, see *Castles Brian Complexes*, p. 141.

*Ryana wants to build a very large shopping mall complex, complete with interior atrium. This complex, she decides, will have a large central building for the atrium, a main building and six smaller structures to reflect outlying shops. As they will all be combined in a civilian shopping complex, like so many among the mercantile districts of most Inner Sphere realms, Ryana chooses to build all seven structures with an Inner Sphere technology base, and chooses the Standard building classification.*

*A Standard-class building may be constructed with a Light, Medium or Heavy building type, but while Ryana intends her mall to be sturdy, she just doesn’t see a Heavy type as practical for her needs, even for the larger central building. She thus constructs the central building as a Medium type, while assigning the outlying smaller buildings a Light building type.*

INTRODUCTION

ADVANCED  
GROUND MOVEMENT

ADVANCED  
COMBAT

ADVANCED  
BUILDINGS

ADVANCED  
SUPPORT  
VEHICLES

GENERAL  
RULES

ADVANCED  
SUPPORT VEHICLE  
CONSTRUCTION

ADVANCED  
WEAPONS  
AND EQUIPMENT

INDEX

RECORD SHEETS



The Medium Standard building serving as her mall's central structure has a CF range of 16 to 40 points, and a maximum size of 8 hexes and 8 levels of height. The Light Standard buildings she's using for the outlying shops have a CF range of 1 to 15 points, and a maximum size of 6 hexes and 5 levels. Ryana opts to give the central building the maximum CF of 40, and designs it as a ring-shaped building six hexes in total size (leaving a central, open hex to represent the atrium) that stands three levels high. (This gives it an internal weight capacity of 120 tons per hex [CF 40 x 3 Levels = 120].) The six smaller, identical structures, she decides, will receive their maximum CF rating of 15, and will ring the complex's central structure, with each shop building taking up only one hex and standing 2 levels high. (This gives the shops an internal weight capacity of 30 tons per hex [CF 15 x 2 Levels = 30].)

Kenyon wants to build a static defensive battery to defend one of Clan Hell's Horses' newly won mining enclaves in the Inner Sphere. As this is for Clan use, he chooses a Clan technology base. He then chooses a Gun Emplacement building classification, preferring the advantages of a simpler static weapon over a built-up structure that can be entered and such.

With the full range of building types—Light through Hardened—open to him, Kenyon decides on a Heavy type, which provides a CF range of 41 to 90 points. Kenyon wants his gun emplacement to be well protected and well armed, and so chooses a CF of 80 for this structure.

Gun emplacements have a fixed size of 1 hex by 1 level tall, which locks in the size and shape of Kenyon's building design and sets the internal weight capacity of these buildings at 80 tons (CF 80 x 1 Level = 80).

Tara doesn't want to take a lot of time designing a lot of buildings from scratch. Instead, she decides to modify a few buildings on a pre-existing map for use as the central building in a major military base. One that catches her eye is the Hardened structure on the far right side of the City (Residential) mapsheet (from Map Set #6). As this is a multi-level structure, by the rules of advanced building construction, it actually qualifies as three buildings in a single joined complex.

The central building is Hardened, 5 levels tall, and occupies a total of six hexes in a triangular pattern. To either side of this central building are two slightly smaller buildings, each of which is Hardened, 4 levels tall, and occupies 6 hexes in a simple two-hexes-by-three-hexes trapezoidal shape. This establishes the type, size and shape of these buildings, but Tara must still identify the buildings' classifications and CF values.

Tara decides to classify all three of these structures as fortress buildings, and assigns all three the maximum CF values allowed under that classification: 150 points. This means that the central building, at 5 levels in height, will have a total internal weight capacity—per hex—of 750 tons (CF 150 x 5 Levels = 750), while the other two buildings receive an internal weight capacity of 600 tons per hex (CF 150 x 4 Levels = 600).

## STEP 2: ADD ARMOR

All buildings have an inherent protection—representing the level of engineering and toughness of the materials used in their construction—that is quantified for game purposes in their Construction Factor values. Some buildings, however—most notably those designed specifically for military use—may add armor as well, providing a level of protection beyond that of mere architecture.

In game play, a building's armor must be destroyed before the structure itself can sustain damage in accordance with the normal rules for attacking buildings. This armor is purchased in tonnage, as it is for other combat units, but is applied to the entire building in a uniform manner as an Armor Factor. This Armor Factor abstracts the level of protection provided by armor, regardless of the direction of attack (so a single-hex advanced building with a CF of 40 and an Armor Factor of 30 can sustain a total of 30 points of damage—regardless of the direction of attack—before damage is applied directly to the building's CF).

Only Wall, Gun Emplacement, Fortress and Castles Brian building classifications may install armor. Hangars, standard buildings, fences and bridges may not install armor. Armor is only installed in full-ton lots for buildings, and the same amount of armor must be installed on each hex of a building. The armor applied to a hex counts against the internal weight capacity of the hex being armored (so a 3-hex building that installs a ton of armor per hex counts only 1 ton against each hex's internal weight capacity, rather than the full 3 tons of armor installed on the structure). Armor does not affect the building's external weight capacity or ability to support other units inside.

The maximum number of armor points an appropriate building may receive is noted on the Building Classifications and Types Table (see p. 115).

**Technology Base and Building Armor:** For Inner Sphere-made buildings, each ton of armor provides 16 points of protection to a single building hex. Clan-made buildings (which benefit from slightly superior architectural, metallurgical and engineering design) receive 20 points of armor per hex for each ton of armor installed. Advanced buildings may not install other specialty armor types. This armor is assigned in standard-scale points; to convert to capital-scale armor (for Castles Brian structures), simply divide the armor value by 10 and round down after all armor is installed.

Building armor is added in half-ton lots.

Ryana's shopping complex, made up of Standard-class buildings, may not install armor.

Kenyon's gun emplacement can be armored, and with a CF of 80, it may receive up to 80 points of armor per hex. As the emplacement was built using Clan technology, Kenyon will receive 20 points of armor (per hex) for every ton of armor installed. Since the building occupies only one hex, Kenyon decides to install the maximum armor—80 points—on his gun emplacement, spending 4 tons from the structure's internal weight capacity in the bargain (20 points per ton x 4 tons = 80 points). The gun emplacement now has enough room for 76 tons of weapons and equipment.



Tara's Fortress-class buildings may install armor, if desired. Though all three structures together make up a complex, she decides to armor only the central building, leaving the others without armor. The central building has a CF of 150 points per hex (so it may support up to 150 armor points per hex), and a total internal weight capacity of 750 tons per hex. Because armor has to be mounted in full-ton lots, Tara quickly realizes that 150 points of armor on an Inner Sphere building would require 10 tons per hex (150 maximum ÷ 16 points per ton = 9.375 tons of armor, rounded up to 10). Rather than waste tonnage, Tara decides to install 9 tons of armor per hex instead, which will provide the central building with 144 armor points per hex (9 tons x 16 points per ton = 144 points). Each hex now has an internal weight capacity of 741 tons (750 – 9 = 741).

### STEP 3: INSTALL COMPONENTS

Advanced buildings may install weapons, heat sinks and other equipment in accordance with the rules for mounting weapons and equipment on Mobile Structures (see p. 266), but with a few modifications as outlined below.

#### Unspecified Equipment

Buildings often have broadly varied functions—ranging from simple residences and shopping complexes to hospitals, factories and administrative centers. In many cases, equipment that already exists for use with Mobile Structures, Support Vehicles and the like can be used to provide in-game functions and features that further define a building's purpose. Many players, however, may find exploring such options tedious for buildings (which are often seen simply as a sophisticated piece of terrain or a mission objective).

Thus, at the designer's option, some (or all) of a building's design may be left aside for "unspecified equipment." This equipment would have no effect in game play, but would instead be used as "filler" without defining an entire structure as an empty cargo space or generic quarters.

#### Light and Medium Weapons

Only hangars, standard buildings and walls may mount Medium and Small weapons (weapons listed on the Conventional Infantry Weapons Table in *TechManual*; see pp. 349-352, *TM*). These building classes may mount a maximum of 6 such weapons per hex for each level of the building's height.



RH

Mad Cat and Savage Coyote, Delta Galaxy (Clan Coyote)

#### Heavy and Capital Weapons

Only Gun Emplacement-, Fortress- and Castles Brian-class buildings may carry Heavy weapons. Only Fortress- and Castles Brian-class buildings may carry Capital weapons. For the purposes of these rules, Heavy weapons are all weapons weighing 0.25 tons or more that are available to 'Mech or vehicle units, while Capital weapons cover all weapons that use capital-scale damage and range values.

The rules and limits for mounting Heavy and Capital weapons on buildings are the same as those used for mounting such weapons on Mobile Structures (see pp. 266-267).

#### Power Systems and Power Amplifiers

The rules presented here generally presume that a given advanced building is drawing power indirectly (either from the local energy grid, or through a power collection system such as solar power). Buildings intended to operate independently of the local grid—such as gun emplacements, fortresses and Castles Brian—may find independent internal power supplies far more preferable. See *Power Generators* (see p. 133) for information on incorporating power systems into an advanced building design.

**Power Amplifiers:** Any building drawing power indirectly or through a non-fusion or non-fission generator must add power amplifiers for any and all Heavy- or Capital-class energy weapons mounted on the unit. The weight of such amplifiers is equal to 10 percent of the weight of all such weapons mounted in the hex (rounded up to the nearest .1 tons). Power amplifiers do not count toward the weight of any weapons slaved to a targeting computer, nor do they count toward the weight of any turret or pintle mechanisms mounted on the building, but their weight must be assigned to the hex locations where their related weapons are mounted.

#### Crew Systems and Quarters

By and large, buildings do not require a crew to run them. However, any equipment installed within an advanced building (such as weapons, communications systems and medical facilities) may require crewmen to operate in game play. To determine how many crewmen are required to operate an advanced building's equipment, consult the Advanced Building Minimum Crew Table below.

**Crew Quarters:** Unlike Mobile Structures and other battlefield units, advanced buildings do *not* require quarters to meet any crew needs unless they are specifically designed to operate far from local population centers or even a barracks of their own. Gun emplacements, for example, may require crew quarters for long-term habitation and immediate operation, as might a fortress with communications and medical support facilities, but civilian-focused buildings can make do with a "crew" that arrives via the morning commute.

**Passenger Quarters:** Also not a required part of advanced building design, passenger quarters may nevertheless be used to represent everything from hotel room space to residential quarters, or even shops, offices and cafeterias in a large building. For more technical and support applications, appropriate cargo space, transport bays or cubicles (see p. 239, *TM*) may be used to reflect specialized-function equipment (such as 'Mech cubicles for a 'Mech repair hangar), to indicate the building's intended capacity where people and machinery are concerned.

INTRODUCTION

ADVANCED  
GROUND MOVEMENT

ADVANCED  
COMBAT

ADVANCED  
BUILDINGS

ADVANCED  
SUPPORT  
VEHICLES

GENERAL  
RULES

ADVANCED  
SUPPORT VEHICLE  
CONSTRUCTION

ADVANCED  
WEAPONS  
AND EQUIPMENT

INDEX

RECORD SHEETS



**Quarters Space:** If a designer opts to install quarters, they may be divided as evenly as desired among all of the building's hexes and levels.

## ADVANCED BUILDING MINIMUM CREW TABLE

### Minimum Crew Formula:

Minimum Crew Needs = Minimum Non-Gunners  
+ Minimum Gunners + Minimum Officers (if required)

Non-Gunners	Minimum Crew Requirement
Communications Equipment (per ton, see p. 212, <i>TM</i> )	1
Field Kitchen (per item, see p. 217, <i>TM</i> )	3
Flight Deck (per item, see p. 312)	20
Landing Deck (per hex, see p. 319)	3
Helipad (per item, see p. 312)	5
MASH (per theater, see p. 228, <i>TM</i> )	5
Mobile Field Base (per item, see p. 330)	5
Modular Structure Linkage (per item, see p. 265)	4

Gunners	Minimum Gunners*
Per Light Weapon (see p. 131)	1
Per Medium Weapon (see p. 131)	1
Per Heavy Weapon (see p. 131)	Weapon Tons ÷ 5 (round up)
Per Capital Weapon (see p. 131)	7

\*Gunners are required only for items that require a Gunnery Skill Roll to use in combat.

Officers	Minimum Officer Requirement*
9 Non-Officer Crewmen or less	1
10 or more Non-Officer Crewmen	Total Non-Officer Crew ÷ 10 (round up)

\*Officers are not required for advanced buildings that are non-military in nature.

Because she sees her buildings as part of a shopping complex that draws power from the local grid, Ryana has little need for sophisticated equipment or generators. But rather than assign the various shops as undefined equipment—like any random structure on a mapsheet—she decides to use quarters to reflect the main stores and even some field kitchens to reflect a food court.

For the Light outlying buildings, Ryana assigns two second-class quarters worth 7 tons each, plus two more steerage-class quarters (at 5 tons each), to reflect two medium-sized shops and two smaller shops in each building. With a total of 24 tons spent, Ryana leaves the 6 remaining tons to standard cargo, which she envisions as stockrooms for these outlets.

For the Medium central building, Ryana installs 3 first-class quarters (10 tons each), 3 second-class quarters (7 tons each) and 6 steerage quarters (5 tons each) per hex, for a total of 81 tons. She then nominates three of the six central hexes (each 1 hex apart) to receive field kitchens (each worth 3 tons) for her food court (the central atrium, as she sees it, will serve as an open-air dining area to connect them). This leaves the central building with 39 tons of space in 3 hexes, and 36 tons in the other 3 hexes. Deciding that the mall is packed well enough, Ryana leaves the remaining space for storage and stockrooms. Her mall complex is complete.

No crew is required to operate Ryana's mall, but she does know from the Advanced Building Minimum Crew Table that the food court has a requirement of at least 9 employees. She also feels that each of the shops ("quarters") she assigned should have a minimum of 3 employees each during the day—a rather arbitrary figure on her part, but one fitting the spirit of the structure. Each Light building hex thus requires 12 employees, while each Medium building hex employs 36 associates. These employees will all be able to commute to work, so no additional quarters are necessary here. Thus, on any given shopping day, her mall will house 297 employees  $([6 \times 12 \text{ outer building hexes}] + 9 [\text{food court}] + [6 \times 36 \text{ inner building hexes}] = 297)$ . As the shopping mall complex is not a military compound, no officers are required.

Kenyon's gun emplacement can carry up to 76 tons' worth of weapons, ammo, heat sinks and—if necessary—power systems and crew quarters. In an effort to maximize the emplacement's potential, he decides that the building can draw power from external generators, and that the crew can commute from the nearby base, rather than living in the weapon platform. This leaves all the internal tonnage capacity for weapons.

Kenyon decides that the primary weapons for his emplacement will be a pair of Clan ER Large Lasers (which weigh 4 tons each). Because these are energy weapons that generate 12 points of heat each, Kenyon must also spend 24 tons on heat sinks. Furthermore, because the building is drawing power indirectly, he will also need to install 0.8 tons of power amplifiers  $(8 \text{ tons of heavy energy weapons} \times 0.1 = 0.8 \text{ tons})$ . With 32.8 tons spent on these weapons, Kenyon decides to back up the lasers with a pair of Artemis IV-enhanced LRM-20s (6 tons each; 12 tons total), and adds 5 tons of ammo per launcher (for a total of 10 tons of ammo). Because they are missile weapons, heat sinks and power amplifiers are not required. Thus, the final weight for all weapons, ammunition, heat sinks and power amplifiers comes to 54.8 tons.

Kenyon decides that all four weapons will be placed in a turret, to maximize the emplacement's flexibility in battle. As the lasers weigh 4 tons each and the LRMs weigh 6 tons each, and all heat sinks, power amplifiers and ammunition are not counted, this yields a turret weight of 2 tons  $([(2 \times 4 \text{ tons for lasers}) + (2 \times 6 \text{ tons for missile launchers}) = 20 \text{ tons}] \div 10 = 2)$ . With 56.8 tons spent, Kenyon finds that his gun emplacement still has 19.2 tons remaining. After some thought, he decides to allocate 5 of these tons to a battle armor transport bay, to reflect a place for a Point of support troops, and leaves the remaining 14.2 tons to a generic storage bay for supplies.



Tara is not as interested in detailing every feature of her Fortress-class buildings as the others have been. There are only a few items of interest she'd like to place in these structures: a helipad, communications equipment and a power generator that will enable the structures to remain independent of the local grid. The rest, she decides, will be unspecified equipment centered on the buildings' primary role as a military administrative center.

To make matters even simpler, Tara decides that all the equipment she has in mind can be placed in the central building. Looking up the Power Generators rules, she determines that her three buildings require 78 hexes of power ( $[6 \text{ hexes} \times 5 \text{ levels} = 30 \text{ hexes for the central building}] + [2 \times [6 \text{ hexes} \times 4 \text{ levels for the secondary buildings}] = 48] = 78$ ). Opting for a fusion-type generator, Tara multiplies this by 1 (fusion generator weight multiplier) to find that the generator will take up 78 tons in total weight. Tara decides to distribute the weight evenly among the building's six hexes, reducing their 741-ton capacities by 13 tons (to 728 per hex).

The helipad, at 500 tons, Tara places at the top of the central hex (leaving 228 tons there), while she places 9 tons' worth of communications equipment in another hex (on the third level, just in case advanced building rules will be used). The remaining internal space—in all hexes—Tara assigns to "unspecified equipment," allowing her to complete the design process.

#### STEP 4: COMPLETE THE RECORD SHEET

Once an advanced building's size, shape, CF, armor, weapons and equipment are established, a blank Structure Record Sheet can be used to record these specifics for game play. (This is the same record sheet as the Mobile Structure uses.) All data on the advanced building must be filled in for the Structure Data block (including name, building type and CF—though all advanced buildings constructed according to these rules receive a value of "NA" for MPs). All equipment slots must be allocated on the Weapons and Equipment Inventory (including ammunition and number of shots per bin), making certain to note in which hexes the items have been placed as well as their facings (turreted weapons should be noted with a "(T)" and pintle-mounted weapons should receive a "(P)" notation).

Finally, all extraneous hexes must be blacked out on the structure's mapsheet diagram.

Once all of the above is completed, the advanced building is ready for game play.

**Multiple Buildings/Complexes:** In the case of multiple smaller buildings and complexes, if the hex space on the Structure Record Sheet permits, multiple buildings may be laid out on the record sheet's mapsheet diagram in a manner corresponding to their positions on the game map. Using the record sheet's hex numbers, players can track equipment across the separate buildings as easily as across a single larger building.

## ADVANCED BUILDING EQUIPMENT

Advanced buildings may install any of the equipment featured in *TechManual* that is specifically identified as being available to DropShips on the Equipment tables (see pp. 341-345, *TM*). Buildings may also employ any items shown in the Advanced Weapons and Equipment rules (starting on p. 274 of this book) that are specifically noted as being available to Mobile Structures.

In addition, the following items and design options are available for the appropriate building classifications and types, reflecting extra features not commonly found on DropShips or Mobile Structures.

### AUTOMATED WEAPONS

Automated weapon systems are available to any advanced building that may carry weapons. Controlled by little more than a basic pre-programmed fire control system slaved to a standard sensor array, automated weapons fire on the closest non-friendly target unit within their range (or at a randomly determined non-friendly target, if more than one is at the same distance). This attack is resolved using a fixed base Gunnery Skill of 5, and takes place first during the Weapon Attack Phase (regardless of initiative order). An additional +1 modifier applies to an automated weapon attack if the line of sight passes through or into a hex covered by a hostile ECM field (or if the automated weapon system itself is subjected to a hostile ECM field).

**Construction Rules:** Only Heavy-class, non-artillery weapons may be used with an automated control system. Automated control systems also may not use any weapons that require no Gunnery Skill to fire (such as anti-missile systems, A-Pods, B-Pods and electronics). The control system replaces the standard fire control systems (for the same weight, size and cost), but requires no crew to operate.

### POWER GENERATORS

For most structures and facilities, it is generally presumed that any power needs are met by the capacity of a local power grid. Where desired, however, players may opt to install independent power generators for their advanced buildings. Power generators for static buildings differ significantly from the power systems used in Mobile Structures, in part because they do not need to provide enough power for a massive, distributed motive system. Building power systems may also be used to power multiple buildings within a "power grid," often by a system of suspended cables, underground conduits and such.

Advanced buildings may draw power from any one of the generator types shown on the Power Generators Table below. The listed generator types provide a Generator Weight Multiplier (used to find the generator's total weight), Daily Fuel Weight (in tons, per every five hexes of buildings requiring power) and any special notes about the generator's design and use (such as minimum building sizes, explosive hazards and such).

INTRODUCTION

ADVANCED  
GROUND MOVEMENT

ADVANCED  
COMBAT

ADVANCED  
BUILDINGS

ADVANCED  
SUPPORT  
VEHICLES

GENERAL  
RULES

ADVANCED  
SUPPORT VEHICLE  
CONSTRUCTION

ADVANCED  
WEAPONS  
AND EQUIPMENT

INDEX

RECORD SHEETS



Generators may power one or more buildings, and may even be supplemented by power from other generators. There is no practical limit on how many generators may power a building or group of buildings; most industrial or commercial complexes tend to use no more than two or three generators, while residential areas tend more toward external power supply from a distant but dedicated generator complex. Military complexes can vary more, with one or two generators providing power to the main facilities, while static defenses receive their own internalized power generators for independent operation.

Regardless of the arrangement and nature of any power generators installed, if a building hex housing generators is destroyed (or the fuel supply for such generators is destroyed or depleted), the affected generators will cease providing power to any buildings in their grid. Any building that finds itself without power as a result may not operate any Heavy weapons, communications systems or other electronics. A building receiving power from multiple generators receives no additional benefits beyond losing power only after all power sources are destroyed or disabled.

**Construction Rules:** To find the Base Generator Weight for an advanced building (or a complex of buildings), add up the total number of hexes for all of the advanced buildings intended to receive power except for Tent-, Fence-, Wall- and Bridge-class buildings. In the case of multiple-level buildings, multiply the building's hex-count by its height in levels—plus any basement levels—before adding it to the sum (so a 3-hex building that stands 4 levels in height is worth 12 hexes). Add to this sum 10 percent of the total tonnage for all Heavy-class energy weapons used by any of these buildings. This is the Base Generator Weight.

Next, multiply the Base Generator Weight by the appropriate Generator Weight Multiplier, and round up to the nearest whole number. This is the weight of a single power generator. The generator may be housed within a single building, with its weight distributed as evenly as possible across all the generator building's hexes as necessary. (For example, a 960-ton generator might exceed the weight capacity of a single hex of a 2-level, CF

90 Heavy fortress with its per-hex weight capacity of 180 tons, but if the building occupies 6 hexes, its total weight capacity of 1,080 tons [ $180 \times 6 = 1,080$ ] would allow it to support the generator's weight at 160 tons per hex [ $960 \div 6 = 160$ ].) Multiple generators may be installed within a single building, if desired, but the designer should bear in mind which generators occupy which hexes, as the destruction of even a single hex assigned to a generator will render that generator inoperative.

**Generator Fuel:** Steam, Internal Combustion and Fuel Cell generators require fuel to power themselves and other structures. This fuel may be stored in separate storage tanks in other buildings. See *Liquid Fuel/Chemical Storage Tanks* for rules to determine how much fuel such generators require, and how to construct storage tanks to contain the fuel.

### LIQUID FUEL/CHEMICAL STORAGE TANKS

Generators powered by steam, internal combustion or fuel cells require fuel to operate, as do vehicles and other units driven by fuel-based systems, while various other chemical applications may require ample storage and distribution facilities to maintain their liquid supplies.

Fuel storage buildings require no power, so long as they feature no other equipment beyond liquid cargo storage.

Infantry units may not move through a liquid fuel or chemical storage tank, but may ascend the structure along the outside as described under the rules for climbing under *Moving Through Advanced Buildings* (see p. 118). Mechanized and motorized infantry may not ascend the outside of a building. Other units may move into and through a liquid storage tank building per the normal rules, but do so at an additional +1 MP cost and a +2 modifier to Piloting Skill Rolls when doing so. Such actions also cause leaks as described below.

**Liquid Fuel/Chemical Tank Explosions:** If any hex of a liquid fuel/chemical storage building collapses or is otherwise reduced to a CF of 0 by weapons fire or fire effects (see *Fire*, p. 43), the contents of the entire structure may explode on a 2D6 roll of 6+.

## POWER GENERATORS TABLE

Generator Type	Weight Multiplier	Daily Fuel Weight	Notes
Steam	3	1.5	Liquid-based fuel supply required
Solar	3	NA	May not mount other equipment on rooftop*
Fission	1.5	NA	
Fusion	1	NA	
Internal Combustion			
Petrol, Natural Gas	1.5	1	Liquid-based fuel supply required
Coal, Wood	2	2	Solid-based fuel supply required
Fuel Cell	1	1.2	Liquid-based fuel supply required
External (PCMT)**†	0.5	NA	Minimum building size (regardless of height) = 5 hexes per ton of transmitting PCMT (round up); May not mount rooftop equipment*
External (Other)†	0.5	NA	

\*For construction purposes, rooftop equipment is any equipment that uses turrets or occupies turret space.

\*\*Reflects receiver, power storage and distribution for energy transmitted by PCMT equipment (see p. 336).

†Externally-fed power generators store enough power to operate for 1 hour for every 5 tons of equipment (round up).



An exploding liquid fuel/chemical tank will affect all units, structures and terrain within a number of hexes of the storage tank equal to the storage tank's current total fuel capacity (in tons) divided by 1,000 (rounded up). Thus, a storage tank that is holding 2,400 tons' worth of fuel when it explodes will affect all units within 3 hexes of the structure ( $2,400 \div 1,000 = 2.4$ , round up to 3), while a storage tank that currently holds 700 tons of fuel or liquids will only affect all units within 1 hex of the structure ( $700 \div 1,000 = 0.7$ , rounded up to 1).

All units within the area of effect of an exploding liquid fuel/chemical tank building will sustain a base Damage Value equal to the Explosion Damage Value shown for the stored liquid or fuel in the Fuel Tank Leak/Explosion Table below, treated as area-effect damage. (Units sustain this damage based on their facing relative to the exploding storage tank, with any units standing within or on top of the structure sustaining damage to their appropriate Front hit location table.) Multiply this value by the storage tank's maximum effect radius as computed above for all units adjacent to the storage tank, and divide this modified value by the unit's distance from the storage tank for any units within the area of effect but not adjacent to the tank. (Thus, if a liquid storage tank explodes with a base Damage Value of 20 points, but has an area of effect of 3 hexes due to its capacity, any units directly adjacent to the exploding storage tank will sustain 60 points of area-effect damage [ $20 \text{ points} \times 3\text{-hex area} = 60$ ], while any units standing 3 hexes away from the exploding storage tank will sustain only 20 points of damage [ $20 \text{ points} \times 3\text{-hex area} \div 3 \text{ hexes away} = 20$ ].) Any units within or on top of an exploding storage tank's building hexes sustain twice the damage an adjacent unit would otherwise sustain.

If the storage capacity of a liquid fuel/chemical storage tank is unknown, presume that a given storage tank hex can contain up to 546 tons of fuel for every 4 levels in height (or fraction thereof)—reflecting the capacity of a standard 600-ton liquid storage tank; the largest size storage tank possible in a Hangar-class structure. Thus, a 4-hex storage tank that stands 3 levels tall can contain up to 2,184 tons of fuel [ $(546 \text{ tons} \times 4 \text{ hexes}) \times [3 \text{ levels} \div 4 = 0.75, \text{ round up to } 1] = 2,184$ ].

**Liquid Fuel/Chemical Tank Leaks:** If a liquid fuel/chemical storage building is collapsed by non-weapon attacks or fire, or is breached by a unit other than infantry attempting to pass through its walls, the storage tank will not explode, but will instead lose its total liquid fuel (or chemical) capacity at a rate equal to 1 ton for every point of CF damage the building has sustained. This amount is taken from the total liquid storage capacity of the damaged building, but does not affect any linked storage tanks. This fuel will pool up in all hexes adjacent to the fuel storage building (except for those occupied by another building) and is treated as a water feature with a Depth of 0.

The leak will continue for as long as the fuel storage tank remains standing, does not explode, and has contents to spill; for every 3,000 tons of liquids spilled by a leak in this fashion, the radius of the spill will expand outward from the leaking storage tank by 1 hex. Any additional effects due to the liquid type being leaked (such as increased chances for starting fires from spilled fuels) are noted on the Fuel Tank Leak/Explosion Table.

## Generator Fuel

Generator buildings (see *Power Generators*, p. 133) that run on steam, internal combustion or fuel cells also require fuel storage facilities to maintain their operations. To abstract the fuel needs for such facilities, consider that a typical generator of the above-mentioned types burns 1 ton of fuel per day for every 5 hexes of structure (rounded up, regardless of height) that it provides with power (including the generator building itself, but not its fuel storage structures). An additional ton of fuel is also required per *hour* for every building-mounted Heavy weapon among these structures that sees use in combat (even if the period of use is as brief as a few combat turns), while capital-scale weapons burn fuel equal to 10 tons per hour of use. When establishing the daily fuel needs for a generator supplying power to such armed structures, the designer may establish anywhere from 0 to 24 hours' worth of weapon-power fuel per day, but must factor in *all* of the associated Heavy or Capital weapons appropriately when doing so.

Once the daily fuel needs for a given Steam, Internal Combustion or Fuel Cell engine are determined, this figure must be multiplied by the Daily Fuel Weight value for the generator type used (see the *Power Generators* Table, p. 133).

As this fuel is typically burned and replenished on a monthly basis, a power generator's minimum fuel storage should be sufficient to supply a month's worth of continuous power for all the essential structures it supports. For ease of reference, players may compute a month's worth of generator fuel by multiplying the generator's daily fuel consumption rate by 30.

**Coal- and Wood-Burning Generators:** In very rare instances, generators using an internal combustion power source may be fueled by coal or wood. As these are non-liquid fuels that are largely inert, there is no chance of explosion from the destruction of a storage building filled with them. Instead, such fuel stores simply ignite under explosive conditions, with all storage tank hexes catching fire instead of exploding (see *Fire*, p. 43). Leaks from a coal- or wood-storage tank simply spill the fuel out into the adjacent hexes for 1 turn. This spill creates rough terrain in all hexes outside the storage tank that lie adjacent to the breach.



A lance of Death Commandos guard a critical generator station.

INTRODUCTION

ADVANCED  
GROUND MOVEMENT

ADVANCED  
COMBAT

ADVANCED  
BUILDINGS

ADVANCED  
SUPPORT  
VEHICLES

GENERAL  
RULES

ADVANCED  
SUPPORT VEHICLE  
CONSTRUCTION

ADVANCED  
WEAPONS  
AND EQUIPMENT

INDEX

RECORD SHEETS



### Construction Rules

Any building class may be constructed as a liquid fuel/chemical storage tank, but hangars, with their open structure design, are generally the most efficient. To create a liquid fuel/chemical storage tank, the designer must simply devote some or all of a given building's internal tonnage capacity to liquid storage. This fuel/chemical storage counts as a single liquid cargo transport bay (see p. 239, *TM*), meaning that for every ton of structure devoted to liquid storage, the building actually holds 0.91 tons of fuel or liquid chemicals. If the maximum size of a fuel/chemical storage building cannot accommodate all of the fuel/chemicals required, it may be linked to other liquid storage buildings for greater total capacity, but such linked liquid storage tank buildings must be placed in adjacent hexes.

**Non-Liquid Fuels:** The non-liquid fuels (coal and wood) covered under these rules do not use liquid storage, but use standard "dry" storage compartments instead. As a result, the tonnage of non-liquid fuel available to generators using such fuel supplies is equal to that of the cargo transport bay itself (see p. 239, *TM*).

*Paul has built a military base that consists of a total of 80 building hexes, six of which include weapon turrets that house four Heavy weapons each. Having elected to power this with an Internal Combustion generator, he computes that the fuel needs for such a generator to provide daily power to the buildings and up to two hours' worth of active power (per day) for the Heavy guns would come to 54 tons per day ([80 total building hexes ÷ 5 = 16] + [2 hours/day x (6 buildings x 4 heavy weapons = 24)] = 54). As his chosen power source is neither Steam nor Fuel Cell, Paul finds that this value is unchanged for the generator type used (54 tons/day x 1.0 Daily Fuel Weight value for Internal Combustion generators = 54). To supply a months' worth of power needs, Paul computes that his generator building would need fuel storage for 1,620 tons of fuel (54 x 30 = 1,620).*

*Because the storage capacity of a liquid cargo transport bay is 0.91 tons for every ton of equipment space devoted to it, a grand total of 1,781 tons is needed to store the month's worth of the fuel weight computed above (1,620 tons ÷ 0.91 capacity tons per ton = 1,780.22 tons, rounded up to 1,781). Deciding on a Hangar-class building for the job, Paul notes that the maximum internal tonnage capacity of a Hangar-class building (with sufficient CF) is 600 tons per hex for every 4 levels in height (or fraction thereof). A single-hex fuel storage building with such a capacity would need to stand 12 levels high (600 x [12 ÷ 4 = 3] = 1,800 tons of internal weight capacity). Alternatively, a similar-CF, Hangar-class fuel storage building could simply be built as a 1-level tall building occupying 3 adjacent hexes, to achieve the same capacity.*

### ENVIRONMENTAL SEALING

Environmentally sealed buildings are built for occupation in extreme environments such as vacuum, underwater or within toxic atmospheres. Whenever occupied buildings appear in such settings, they are assumed to incorporate environmental sealing.

Whenever a sealed building suffers CF damage in excess of 10 points (per hit), a 2D6 roll must be made, modified as noted on the Sealed Building Breach Table below. If the final, modified result is 10 or higher, the structure is breached. A breached building will not necessarily collapse, but all unprotected personnel and equipment within the building are considered destroyed. (Castles Brian hexes only breach in the hex where the damage occurred.)

Adjacent structures—such as tunnels—may also be breached when a building connected to them is breached, but only if any doors between the two are open at the time. Units attempting to move through the walls or closed doors of a sealed building must make the breach roll first in order to pass. Remember that an armored structure may not sustain CF damage until its armor is destroyed.

### FUEL TANK LEAK/EXPLOSION TABLE

Fuel/Chemical Type	Explosion Used For	Damage*	Leak Effect
Water	Steam Power	0**	-2 to ignite Terrain/Buildings/Units in adjacent hexes
Petroleum	Internal Combustion	15†	+2 to ignite Terrain/Buildings/Units in adjacent hexes
Natural Gas	Internal Combustion	10†	+1 to ignite Terrain/Buildings/Units in adjacent hexes
Volatile Chemicals	Fuel Cells/Chemical	10	+1D6 damage to conventional infantry in adjacent hexes
Aerospace Fuel	Aerospace Engines	20†	+1 to ignite Terrain/Buildings/Units in adjacent hexes
Coal/Wood	Internal Combustion	NA††	Ignore normal leak effects; leak lasts 1 turn; adjacent hexes to breach become rough terrain.
Pressurized Chemicals‡	Chemical Applications	2D6**	+1D6 damage to conventional infantry in adjacent hexes
Other Chemicals‡	Chemical Applications	0**	-1 to ignite Terrain/Buildings/Units in adjacent hexes

\*Explosion damage affects units adjacent to the exploding fuel storage building; double this damage for all units standing on (or inside) an exploding fuel storage building.

\*\*Conventional infantry suffer 4D6 burst-fire damage instead; all other units must make a Piloting/Driving/Anti-Mech Skill Roll to avoid being displaced 1 hex outward from the structure.

†Fire automatically starts in exploding fuel tank hexes.

††Coal and wood for Internal Combustion engines are not stored as liquid fuel, but in powder or pellet forms that are inert under most conditions; if explosive conditions are met, all related fuel storage building hexes catch fire, rather than exploding.

‡Other than the fuels and chemicals noted above



## SEALED BUILDING BREACH TABLE

Target Number to Breach (2D6): 10+

Building Type	Roll Modifier
Light	+2
Medium	+0
Heavy	-2
Hardened	-4
Subsurface/Underwater	+(Depth ÷ 2)*

\*Round up

**Construction: Hangar, Standard, Fortress and Gun Emplacement building classes** intended for vacuum, toxic or underwater environments must be sealed to function in such environments. (Castles Brian receive this benefit automatically, and all other structure types—such as tents—either may not be placed in such environments or lack the sealing requirement because they do not have human-occupied internal spaces to seal—such as walls, bridges and fences.) Constructing an environmentally sealed building requires no allocation of internal weight capacity, but does increase the costs for such structures as a result of the specialized engineering.

### HEAVY METAL SUPERSTRUCTURE

Most advanced buildings (with the main exception of Tent and Fence-class structures) may be constructed using heavier, higher-ferrous metals than normal. A building using such a heavy metal superstructure interferes with the operations of most sensors and targeting systems (excepting those mounted on the building itself). If a line of sight passes through or into any hex that is part of (or adjacent to) a building constructed with a heavy metal superstructure, any weapon attacks, electronics, or communications using that line of sight are affected as if within an electromagnetic interference (EMI) field (see *Electromagnetic Interference*, p. 55). Furthermore, if the players agree, a large concentration of buildings featuring this construction option—such as 15 or more hexes' worth of such buildings per mapsheet—may also constitute a Heavy Industrial Zone (see *Heavy Industrial Zone*, p. 31).

Furthermore, when moving a non-infantry unit into any hex of a building constructed with a heavy metal superstructure, the building hex suffers the normal amount of damage caused by the unit's passage, but a failed Piloting Skill Roll delivers twice the normal amount of damage to the unit (the building's current CF divided by 5, rounded up).

**Construction:** Other than tents and fences, any advanced building that has a Heavy or Hardened building type may be constructed with a heavy metal superstructure. However, this superstructure reduces the available internal weight capacity of the structure by 25 percent (multiply the building's internal weight capacity figures by 0.75 and round down to the nearest whole before adding equipment).

### HIGH/LOW CEILINGS

For various reasons, most buildings may be constructed using higher or lower ceilings than normal. High-ceilinged buildings might include those constructed to serve as amphitheatres or coliseums, while low-ceiling buildings may represent common residential designs. The following rules reflect the impact of such design options on an advanced building in game play.

**High Ceilings:** High ceilings generally range as high as 6 meters—large enough to accommodate most vehicles without difficulty, though many are ill suited to use as hangars. Non-infantry units passing through a high-ceilinged building will be less impeded by the structure, and thus deliver half as much damage (rounded down) to the building's CF as they enter each high-ceilinged hex, while suffering half as much damage from the building in the event of a failed Piloting Skill Roll for movement (see pp. 167-168, *TW*). See *Moving Through Advanced Buildings* (see p. 118) for more information on modifiers and MP costs imposed by each high-ceilinged building hex.

**Low Ceilings:** Low ceilings generally sit as low as 2 to 3 meters in height—scarcely large enough to accommodate most humans without difficulty, though they are not quite cramped enough to slow down personnel. Non-infantry units passing through a low-ceilinged building will be more impeded by the structure, and thus deliver twice as much damage (rounded up) to the building's CF as they enter each low-ceilinged hex, while suffering twice as much damage (rounded up) from the building in the event of a failed Piloting Skill Roll for movement (see pp. 167-168, *TW*). See *Moving Through Advanced Buildings* (see p. 118) for more information on modifiers and MP costs imposed by each low-ceilinged building hex.

**Construction:** Only Standard, Fortress and Castles Brian building classes may be constructed using high or low ceilings. Use of high or low ceilings does not affect a building's internal weight capacity. For simplicity's sake, a building may not combine high and low ceilings, or combine either one with standard ceiling heights (which range around 3.5 to 4 meters).

### INDUSTRIAL ELEVATORS

Elevators are a common enough sight on virtually any building of significant height. Typical elevators, however, are scaled to human operations, with limited capacities intended to handle no more than 10 to 20 adult individuals at any given time. Industrial elevators, on the other hand, reflect lifts designed to accommodate much larger units, such as vehicles, bulk cargo or even 'Mechs.

Industrial elevators have a pre-designated cargo capacity that defines the maximum tonnage of units or cargo they may haul at any one time. If an industrial elevator's maximum capacity is exceeded, it will not move (in either direction) until the load tonnage falls to or below this maximum capacity. Furthermore, an industrial elevator must have an assigned "elevator shaft" length (the area, in levels, that the elevator reaches), as well as access hexsides for all levels within the building (to identify any restrictions to entry and egress). For the sake of simplicity, an industrial elevator's platform is presumed to occupy its entire assigned hex.

To access an industrial elevator, a unit must enter the elevator's hex when the elevator platform is at the unit's current

INTRODUCTION

ADVANCED  
GROUND MOVEMENT

ADVANCED  
COMBAT

ADVANCED  
BUILDINGS

ADVANCED  
SUPPORT  
VEHICLES

GENERAL  
RULES

ADVANCED  
SUPPORT VEHICLE  
CONSTRUCTION

ADVANCED  
WEAPONS  
AND EQUIPMENT

INDEX

RECORD SHEETS



height within the structure, so it is important to keep track of where the elevator is both in terms of the building's hexes and its level within a structure. Industrial elevators ascend and descend at a rate of 1 level per turn (regardless of load size), and each level moved is counted as 1 Walking/Cruising MP to any units within, to reflect the time spent in transit. (For example, if a *Griffin IIC* with a Walking MP of 6 began a turn adjacent to—and facing—an elevator hex, and the elevator platform was present, the 'Mech would spend 1 MP entering the elevator, 1 MP descending to the next level below, 3 MP to turn around—to face the exit—and 1 final MP to step out again, now one level lower.) Units may only use Walking/Cruising MP when entering, using or exiting an industrial elevator.

Industrial elevators only travel up and down within a building, never into adjacent hexes. If any level of an industrial elevator's hex is breached, flooded or collapsed, the elevator ceases to function.

To call an industrial elevator (if the platform is not already on the same level as the unit looking for a ride), the calling unit must be in a hex adjacent to the industrial elevator's platform and its controlling player must announce during the End Phase that the elevator is being called. If multiple calls are made in this fashion, the elevator platform will arrive in the order of the calls received, moving to each call location at 1 level per turn (so it is important to know when and where an elevator platform is called to). If multiple calls are made in the same End Phase, the elevator will move to the nearest of the callers before going to the next nearest after that and so on. (If multiple calls are made in the same phase by units at the same distance from the platform, the controlling players must roll initiative against each other to determine which one sees the platform first.)

Stacking rules apply as normal within an industrial elevator's platform hex.

If any unit enters an elevator's hex when the platform is not present, the unit will fall toward the bottom of the building until it hits the elevator platform or the bottom of the elevator shaft, whichever has the higher elevation.

**Construction:** Industrial elevators weigh 1 ton for every 20 tons of desired carrying capacity (rounded up to the nearest whole ton), times the number of levels they are designed to access. An industrial elevator may not be built with a carrying capacity greater than its building's CF, nor can it access levels higher or lower than the building itself. An industrial elevator can be made to reach the building's rooftop, but doing so precludes the installation of any rooftop items (or any items that occupy "turret space") in the same hex as an industrial elevator.

No additional equipment can be placed on any level of the hex where an industrial elevator is meant to reach, but if the elevator does not reach those levels within its hex, additional items may be placed in the hex. (For instance, if the industrial elevator of a 12-level building only operates from the first through sixth levels, equipment may be placed in the elevator's hex as long as it is assigned a height of Level 7 or higher.)

While the entry and egress hexsides of an industrial elevator may vary from level to level within a building, these hexsides may not include any of the building's outermost hexsides.

The location of a building's industrial elevator, its capacity, the range of levels it can reach, its access and egress hexsides (per level) and its current elevation must be tracked on the building's Structure Record Sheet.

## LARGE DOORS

As with elevators, exterior doors are a commonplace (and generally necessary) component in any building's design. Like elevators, doors are not strictly limited to human-scaled sizes, but can also come in large-scale "industrial grade" sizes intended to accommodate vehicles or even BattleMechs. The following rules cover these large doors, and how they apply to entering or exiting buildings.

Doors can be opened or closed only during the End Phase of a turn, and the same door cannot be opened and closed during the same turn. Only the force controlling a building may open or close the building's door, unless the opposing force can get at least one infantry platoon inside the building (per standard rules) to seize the door controls. (In order to accomplish such a feat, the attacking infantry unit must clear all enemy units from the hex where the door is located and remain in that hex for a full turn; the door will then open or close as desired in the End Phase of that turn.)

Vehicles and ProtoMechs can pass through any open large door without taking damage; 'Mechs can only pass through open doors that are 2 or more levels high. An open door in a Wall-class structure allows units to pass through that hexside of the wall as though the wall was not there. Open large doors in other building types allow units of suitable size to enter the building without sustaining damage or inflicting damage to the building. However, moving from hex to hex within a fortress or building may still cause damage to the structure and the unit. (See *Moving Through Advanced Buildings*, p. 118.)

Any unit that attempts to walk through a closed large door inflicts and takes damage in the normal fashion, as if the unit were passing through the building's walls.

**Construction Rules:** Like bay doors in vehicle or spacecraft designs, large doors take up no tonnage in a building's design. Large doors can be installed in Hangar, Fortress, Gun Emplacement, Castles Brian and Standard-type buildings, as well as in walls and fences. (Tents and bridges may not install large doors.)

Doors may only be placed on a building's outer hexside (wall and fence doors take up a whole hexside in the wall or fence's length). Door heights may range from 1 level to the height of the building itself, but each hexside may have a maximum of only one large door. Each door's height and hexside must be assigned during construction.

## OPEN-SPACE CONSTRUCTION

Similar in many ways to hangar construction, open-space construction is a far more sophisticated and large-scale design feature that is used to effectively construct super-massive enclosures such as sealed air domes and elaborate man-made caves. Though this construction option is considered exclusive to the Castles Brian Building class (to establish the minimum CF strength required for such engineering), open-space construction is not actually limited to the design of Castles Brian complexes, but may be found on pre-Castles Brian complexes, such as early human hostile-atmosphere colonies built on land, underground or even underwater.

A building with open-space construction has no walls except along the outer edges of the structure, and the few columns that extend from ceiling to floor have no effect on visibility or mobility in such areas. For movement purposes, each hex of a building made using open-space construction is treated as a paved/road hex by all units (skidding rules and such apply in such hexes as



normal). For combat purposes, open-space construction also negates any terrain modifiers for line of sight or weapons fire within buildings that have this feature, but only as long as the target of such attacks is a non-infantry unit. Any infantry units operating within an open-space building hex can benefit from various minor ground-cluttering features, and so receive the terrain benefits of being inside a light woods hex (rather than a paved hex), if attacked.

Attacks against the wall or ceiling of a building made using open-space construction will create a devastating collapse effect if they successfully reduce the hex's CF to 0 or less. In the event of such a collapse, a building will suffer varying effects based on its nature as an underwater, surface or underground building, as follows:

- **Underwater Collapses:** Underwater building hexes with open-space construction will start to flood the entire building if they collapse. In the End Phase of the first turn in which such a collapse occurs, the entire building instantly fills with water at a Depth of 0 (relative to the building's floor). This water level will rise toward the building's roof at a rate equal to the number of levels of water above the building's highest level, divided by 5 (rounding up), per turn. Thus, if a building with open-space construction is 16 levels below the ocean surface and suffers a hex collapse, the water will pour in at a rate equal to 4 levels per turn ( $16 \div 5 = 3.2$ , rounded up to 4).
- **Surface Collapses:** If a surface building hex with open-space construction collapses, it instantly fills with the exterior atmosphere (or loses its atmosphere, if the exterior environment lacks one). The resulting atmospheric conditions take effect after the End Phase of the following turn, before which any unprotected personnel units equipped with (but not using) environmental survival gear must roll an 8+ on a 2D6 roll (made for each appropriate unit) to avoid any terminal effects.
- **Underground Collapses:** If an underground building hex with open-space construction collapses, it results in a cave-in. In this case, however, not only will the ceiling of the hex that suffered damage fall into the building, but surrounding hexes also collapse into the building. An underground collapse will affect a distance of 1D6 hexes outward from the hex of the original breach (excepting those hexes that represent the collapsing building's wall or another building). The base damage inflicted by the falling debris is equal to one-tenth of the building's original CF, multiplied by sum of the building's height and the number of levels between the building's uppermost level and the ground surface (divided by 5, rounded up). (Remember that Castles Brian buildings use capital-scale Construction Factors, with every point of CF translating to 10 points of standard damage.) Thus, if the ceiling of a 7-level tall, Capital-CF 100 Castles Brian building located 7 levels below the surface collapses, all units below the breach (or within 1D6 hexes of it) will suffer 900 points of damage ( $[(100 \text{ Capital CF} = 1,000 \text{ CF} \div 10 = 100) \times [7 \text{ levels tall} + (7 \text{ levels below ground} \div 5 = 1.4, \text{ rounded up to } 2)] = [100] \times [9] = 900$ ).
- **Underground and Underwater:** If an underground building that suffers a collapse lies beneath ground that is also underwater (such as beneath a lake bed), a col-

lapse also creates an underwater flooding effect on a 2D6 roll of 10 or higher. Add 2 to this target number if the building's roof is deeper than 6 levels below the water's lowest depth in the collapsed hex (meaning 6 levels of ground separate the roof of the collapsed hex and the water levels above it). Subtract 2 from this target number if the number of ground levels between the building's rooftop and the water's depth above the collapse is 4 or 3; subtract 4 from the target number if the ground between the roof of the collapsed hex is less than 3 levels below the water's depth.

- **Construction Factor (Expanded):** The Expanded Construction Factor rules allowing for damage (and breaches) to be contained to a single level does not apply to buildings using open-space construction.

**Construction Rules:** Open-space construction is available only to Castles Brian-class buildings. Because its primary function is to provide a super-large "umbrella" over a large area, buildings constructed with this feature have a maximum internal weight capacity of 600 tons, regardless of the CF chosen, and all equipment must be located on the building's ground level. Buildings with open-space construction cannot install any rooftop equipment, including turrets.

Because of the large-scale framework, a building with open-space construction can accommodate other buildings inside its area. Such buildings may be of any height and size desired (even taller than the open-space building, reflecting structures that rise up and through—such as industrial elevator shafts), but their hex areas must lie entirely within the open-space building's outer hex area. Buildings that connect with an open-space building from the outside reflect tunnels or other external structures.



WER-LF-005 Werewolf, Independent Solaris VII MechWarrior Itsura "Hellhound" Mikasai

INTRODUCTION

ADVANCED  
GROUND MOVEMENT

ADVANCED  
COMBAT

ADVANCED  
BUILDINGS

ADVANCED  
SUPPORT  
VEHICLES

GENERAL  
RULES

ADVANCED  
SUPPORT VEHICLE  
CONSTRUCTION

ADVANCED  
WEAPONS  
AND EQUIPMENT

INDEX

RECORD SHEETS



## SUBSURFACE/UNDERWATER STRUCTURES

As a more complex construction option, most building classes and types may be constructed below ground (or underwater), rather than on the surface. Though such structures face certain risks surface buildings do not (such as the threat of collapse or flooding), their practical and strategic advantages cannot be denied.

**Construction:** Subsurface buildings use all of the existing rules for construction, with the following exceptions:

- For a building to be considered subsurface, its highest elevation must be at least one level below the surface of the ground (or body of water). Underwater subsurface structures—including those built beneath the “floor” of the water feature as an underground building—also require environmental sealing, and may be constructed at a depth no deeper than their CF (thus, an underwater Light hangar with a CF of 8 may not be constructed at or below a Depth of 9). No such sealing is necessary for underground structures (unless the native atmosphere is unbreathable).
- Only buildings, hangars, fortresses, tunnels and Castles Brian may be built as subsurface structures.
- Except for Castles Brian, the maximum building sizes (both in terms of height and number of hexes) for all underground subsurface structures are reduced to one-half their surface versions, rounded up (for example, an underground Hardened fortress building can be a maximum of 15 levels “high” and occupy no more than 10 hexes:  $30 \div 2 = 15$  and  $20 \div 2 = 10$ ).
- Underground subsurface buildings may not employ rooftop equipment or turrets. (These rules presume that the subsurface buildings are literally carved out of the surrounding earth and rock, rather than constructed within a larger cave; if the latter is the case, disregard this restriction as long as the uppermost level of the underground subsurface building is at least 1 level lower than the cave ceiling.)

**Game Play:** Subsurface buildings in combat are subject to the same rules as their surface-based counterparts, with the following exceptions:

- Units attempting to move through the walls of subsurface structures may not do so under any circumstances if the area beyond the wall is solid rock or earth, but may inflict damage on the walls in order to encourage a collapse. Units in underwater subsurface structures may attempt to penetrate the walls using the same rules for environmentally sealed structures above.
- With the exception of tunnel openings, underground subsurface buildings may be damaged normally only by units standing inside such buildings (see *Attacking Buildings from Within*, p. 121). This also applies to underwater subsurface buildings constructed below the floor of the water feature. Tunnel openings to the surface are exposed to external and internal attacks as a normal structure.
- Underwater subsurface buildings and tunnel openings to them may be attacked by outside units per normal rules.
- Except for Castles Brian, all subsurface buildings that suffer 10 points of damage or more (in any phase) must check for a breach as though they were an environmentally sealed structure, whether or not they actually feature environmental sealing. This breach check uses the Sealed Building Breach Table (see *Environmental Sealing*, p. 136).

- If an underground subsurface building sustains damage that causes a breach, the hex will collapse. If using the expanded Construction Factor rules (see p. 121), this collapse will be limited to the building level that was breached, but may also produce a top-down collapse, if those rules are also in use.
- If an underwater subsurface building sustains damage that causes a breach, the entire building will flood. If using the Expanded Construction Factor rules, this flooding will be limited only to the level of the building that was breached, as long as the building is not a Hangar- or Tunnel-class structure, but on each turn thereafter, the flood will fill another level lower (toward the bottom of the building). If the tunnel floods with its doors open, adjacent buildings will be flooded as well, starting with their lowest levels and filling upward if the expanded Construction Factor rules are used.
- All equipment and unprotected personnel within a flooded or collapsed subsurface structure are trapped and treated as destroyed in the event of a collapse. Vehicles, 'Mechs, ProtoMechs and suitably protected infantry (including battle armor) within a collapsed subsurface hex suffer damage as though they stood within a collapsing building equal to the height of the subsurface structure, *plus* the height of all ground or water above it.

**Semi-Subsurface Structures:** Semi-subsurface buildings are any building types that have levels both above and below the surface of the map (such as basements, but also including the structures that typically make up mining buildings or Castles Brian). For ease of reference, track such buildings as if they were two separate buildings on top of one another, with construction and use of the surface portion following the standard building rules, and construction and use of the subsurface portion following the rules for subsurface buildings. The following additional rules also apply:

- The area occupied by any surface buildings must be equal to or smaller than that of any subsurface buildings placed below them, and must occupy the same hexes on the mapsheet.
- If the subsurface building is an underground building that connects to the building above and is constructed using the same building type (Light, Medium, Heavy and so on) or lighter, the subsurface half of the building is considered to be a basement, and may not be constructed with a depth equal to more than half the number of levels as the surface building has (rounded down). Thus, a Medium Standard subsurface building placed below a Medium Standard surface building that is 5 levels tall may not have a depth greater than 2 levels ( $5 \div 2 = 2.5$ , round down to 2).
- Underground subsurface buildings with a higher building type than the surface building may be constructed with any desired depth, regardless of the surface building's height.
- If the subsurface building is an underwater (submerged) building, it must be built using an equal or heavier building type *and* a higher CF than the surface building placed above it. Furthermore, the surface building must incorporate environmental sealing, and may not be constructed at a greater height than half the subsurface building's depth (round down). Thus, a Light Standard surface building placed atop a Medium Standard (submerged) building that has a depth of 9 levels may not stand taller than 4 hexes above the surface level ( $9 \div 2 = 4.5$ , rounded down to 4).
- If a subsurface building is of a higher CF and building type than the surface building it sits beneath, normal Basement



rules do not apply for units within the surface building. Instead, a unit will only fall into the subsurface building if its tonnage exceeds the subsurface building's CF.

- If using the expanded Construction Factor rules (see p. 121), when any surface building suffers a top-down collapse to its semi-subsurface structure, all collapse damage is reduced by half (rounded down) once the level of collapsing structure passes the surface level of the local terrain. This includes damage inflicted against the building itself, as well as damage to any units within.

## TUNNELS

Usually used for subsurface structures, but also applicable above ground between sealed structures, tunnels are essentially specialized variations on an empty hangar, and use the same movement rules as such structures (see *Hangars*, p. 116), comprised of two opposing walls and ending on each side in doors. Tunnels are primarily used to connect subsurface buildings to one another, but surface buildings can use the same structures as an enclosed passageway. All normal rules for hangars apply to tunnels.

**Construction Rules:** Tunnels are not an equipment item for advanced buildings, so much as an alternative form of the Hangar-class building. Tunnel construction follows the same basic rules as for hangars, with the following exceptions:

- Tunnels may not install any equipment, either internally or externally.
- Tunnels must connect to at least two separate buildings (or connect one building to a surface structure), and must assign large doors to each connection. If longer tunnel lengths than permitted by the Hangar class are desired, a tunnel may connect to another tunnel, but still requires the door.

# CASTLES BRIAN COMPLEXES

Most building complexes represent a fairly simple arrangement of buildings related by their functions, if not their class and type. Typical examples may include a residential block, a commercial area, an industrial zone or even a warehouse district. Military bases, too, often combine structures of similar overall nature, though many buildings located in such compounds may be mission-specific, including headquarters, barracks, a base hospital and hangars.

Of all the complexes seen in the *Classic BattleTech* universe, Castles Brian complexes (not to be confused with individual Castles Brian-class buildings) may well be the most sophisticated. These elaborate super-fortifications are almost never built entirely on the surface, and most feature elaborate tunnels, hyper-reinforced buildings and construction that embeds them deep within the local terrain for maximum secrecy and defensibility. Though well over half the structures devoted to a Castles Brian complex are often invisible to the casual observer, these sprawling complexes can take up hundreds—if not thousands—of square kilometers, rivaling the sizes of most major cities across the Inner Sphere.

Players interested in mimicking a typical Castles Brian complex should be aware of all construction rules and options, including subsurface buildings, tunnels, environmental sealing (included automatically in all Castles Brian-class buildings), industrial elevators and power generators. Castles Brian complexes also make extensive use of building armor, large doors, weapons (crewed and automated) and design options like heavy-metal superstructures and high or low ceilings. In short, a typical Castles Brian complex may use all of the advanced building concepts introduced in this section.

**Typical Castles Brian Complex Components:** Built exclusively during the days of the Star League, the typical Castles Brian complex included a minimum of 20 armored Heavy weapon turrets, commonly armed with conventional Heavy weapons (rather than Capital weapons). Backing up these turrets were an additional 50 smaller turrets (which carried fewer weapons and were often automated), plus 100 smaller anti-personnel bunkers (typically armed with Light and Medium-class weapons), and an uncountable number of minefields. These turrets—plus a minimum of five vehicle-scale tunnel exits (most of which were concealed within the local terrain)—often comprised the entirety of the complex's surface structures (though a few more elaborate Castles Brian complexes added a complete military base to the surface, including landing strips and control towers for aerospace traffic, for added defense and support).

Below ground (usually deep within local mountains), a typical Castles Brian complex descended around 10 'Mech-scale levels (20 standard game play levels), and included barracks, tunnels, administrative buildings and (of course) massive hangars and garages that could support up to a full tank or 'Mech regiment. Intended to survive any assault up to—and including—a nuclear blast, the typical Castles Brian complex added survivability by alternating habitable levels with additional levels of native rock, to limit any possible collapses to the uppermost levels while the majority of the base's living quarters and supplies remained safely deeper underground.

The sample diagrams shown on the following two pages reflects just one quadrant of what a "typical" Castles Brian complex might look like in game play (to show a full map would take up too much room). Each open space beneath the mountain's terrain reflects a distinct building within the Castles Brian complex, linked by tunnels and large doors wherever appropriate, while an industrial elevator provides for transporting heavy units between the various levels. Players interested in constructing their own Castles Brian complexes should see this diagram and its corresponding Structure Record Sheet map grid as a mere sample of how a portion of a Castles Brian complex might be laid out, and use their best judgment when preparing their own such complexes for game play.

*The map shown on the following page and the corresponding Structure Record Sheet sample represent a portion of a sample Castles Brian complex (the "upper-eastern half"). This complex has been envisioned as having an extensive surface development as well as an elaborate and deeply buried underground system. For simplicity, the surface and underground portions are represented separately here, with the surface installations shown on the standard mapsheet, while the Structure Record Sheet focuses on the*

INTRODUCTION

ADVANCED  
GROUND MOVEMENT

ADVANCED  
COMBAT

ADVANCED  
BUILDINGS

ADVANCED  
SUPPORT  
VEHICLES

GENERAL  
RULES

ADVANCED  
SUPPORT VEHICLE  
CONSTRUCTION

ADVANCED  
WEAPONS  
AND EQUIPMENT

INDEX

RECORD SHEETS



upper levels of the subsurface structures. For further simplicity, the buildings described here have not been fully detailed, but sketched out to show overall arrangement while providing a usable template that players can build on.

In this case, the Castles Brian was constructed on—and within—a mountain (represented by the Large Mountain #2 mapsheet).

As the topside portion is the first line of defense, it has been laced with weapon turrets, ringed by a wall, and features hangars and bunkers to house a fair portion of the complex's active defenders, as well as a surface-based command and communications tower. For this part of the construction, five main building types have been devised:

- The Standard buildings (marked with an "A") each occupy 1 hex and stand 2 levels tall. Built as Heavy, Standard-class structures, these buildings each have a CF of 80, possess no armor and may function as anything from basic administrative structures to barracks.
- The Vehicular Hangars (marked by a "B") each occupy 1 hex and stand 1 level tall. Constructed as Hardened, Hangar-class structures, these buildings have received a CF of 70, possess no armor and can house up to a lance of light vehicles (or two heavy vehicles).
- The Infantry Bunkers ("C" hexes) each occupy 1 hex and stand 1 level tall. Constructed as medium Fortress-class structures, these buildings have a CF of 40, 80 armor points (5 tons of armor, using Inner Sphere technology) and enough bay space for at least two full platoons of motorizing infantry. Six tons have also been reserved to place a fixed-mounted machine gun in each hex facing—each with a half-ton of ammunition.
- The Command Tower (marked by a "D") is the tallest building on the map. It serves as the surface control center for the complex, so it has been constructed as a Heavy Castles Brian building, though it occupies only 1 hex and stands 4 levels tall. The building has a CF of 50 capital-scale points, and has been armored for another 50 capital points (which equates to 500 standard armor points, or 31.5 tons of building armor). Its internal equipment includes various sensors and communications equipment, as well as bays for infantry to provide extra defense against capture.
- Three types of gun emplacements have been established as well, identified on the map by hexes marked "E", "F" and "G." All three types are built as Gun Emplacement-class structures, possess armor and place their weapons in turrets to maximize their field of fire, but each has a different CF, armor value and weapon capacity. The "E" emplacements were established as Light structures, receiving a CF of 15, an equal

amount of armor and six tons of weapons slaved to an automated fire control (see Automated Weapons, p. 123). The "F" emplacements, meanwhile, are Heavy structures, with a CF of 65, 64 armor points and 30 tons of crew-served weapons, plus an independent fusion generator. The "G" emplacements use the Hardened structure type, with a CF of 130, 120 armor points and 100 tons' worth of crew-served weapons and ammunition. Like the "F" emplacements, these batteries also include independent power generators to avoid being quickly disabled by a local grid failure.

- For additional defense, a fence line has been established around some of the buildings in the central compound, with two access gates at the east and west ends. However, with its CF of 1 and lack of armor, this 3-level tall fence would hardly impede a determined enemy force. More effective is the Hardened wall running around the outer rim of the main compound. Standing 2 levels tall, with a CF of 140 and 136 armor points per hexside, this wall produces a barrier that enemy ground units must breach before they can enter the compound. A large door along the main road is the only break seen in this wall from the outside.



• CASTLES BRIAN MAP SAMPLE •



INTRODUCTION

ADVANCED  
GROUND MOVEMENT

ADVANCED  
COMBAT

ADVANCED  
BUILDINGS

ADVANCED  
SUPPORT  
VEHICLES

GENERAL  
RULES

ADVANCED  
SUPPORT VEHICLE  
CONSTRUCTION

ADVANCED  
WEAPONS  
AND EQUIPMENT

INDEX

RECORD SHEETS

- As a final touch, the grounds outside the castle's walls are seeded with various minefields, most of which are either standard fields or command-detonated.

Beneath all this lies the bulk of the Castles Brian itself. Represented on the Structure Record Sheet, where details from the mapsheet have been placed on the structure map's uppermost levels in order to establish a frame of reference (for example, Hex 0403 on all levels of the Structure Map matches the map of 0308 on the Large Mountain #2 mapsheet). To further account for the depths to which the subsurface half of this Castles Brian extends, each level of the Structure Map reflects two levels of depth, rather than just one (for example, the uppermost level of the Structure Map reflects levels 8 and 9 on the surface mapsheet). Most of the subsurface structures noted here fill both of the levels assigned to the Structure Map, unless otherwise noted.

On the Structure Map, colors have been used to indicate specific subsurface structures, with the patterns of the mapsheet duplicated on the uppermost levels to note surface terrain. As above, many of these structures were developed with a common approach:

- The large white areas below the mapsheet-level tiers indicate a vast Castles Brian building constructed with open-space structure, effectively forming a man-made cave. These Hardened structures stand 2 levels tall and use the maximum CF of 150 capital-scale points. As the "outsides" of these structures reflect cave walls, they have no armor to speak of, and merely serve to open the area and provide structural integrity to the underground base.
- The gold structures reflect industrial elevator shafts. These are, in effect, single-hex Castles Brian buildings that extend straight up and down for several levels of the underground complex. Arrows along the hexsides of some levels indicate entrance and egress points for the elevator platform at the "floor" each applicable level. For example, the elevator running through Hex 0706 extends as far down as Level -2 (and possibly lower, if desired, reflecting further sublevels that could house the Castles Brian's main power generators) and as far up as Level 6. It has north and south entry facings on levels -2 and 2, as well as a northern facing on Level 6 (which opens into Hex 0609 on the surface mapsheet). The elevator shaft in Hex 0507, meanwhile, extends as low as the 0706 shaft, but only rises as high as Level 3; its north and south entry points also exist on levels -2 and 2, but its Level 3 egress only opens to the south (reflecting an exit into Hex 0412 on the surface mapsheet). The elevator buildings have an effective CF of 150 capital-scale points, but feature no armor and no significant equipment beyond the elevator system.
- The brown hexes on every tier below the surface map levels reflect solid bedrock. Note that in some cases, entire hex-sized columns of this continue through the open-space Castles Brian hexes. This was not a requirement of the subsurface structure's design, but a deliberate choice to provide some character (and line of sight obstacles) to the underground environment.

**CLASSIC BATTLETECH**  
STRUCTURE RECORD SHEET

**STRUCTURE DATA**  
Description: *Castle Brian West* Levels: 0 thru 8  
MP: 0 Tech Base:  
Movement Type: *Static* Clan:  
Powerplant Type:  *Fusion*  Inner Sphere:

**Weapons & Equipment Inventory** (Invent)  
By Type:  *Mech*  Qty:  *Min. Max. Req. Qty.*

30 Tons of Equipment 101/1  
30 Tons of Equipment 107/1  
30 Tons of Equipment 301/1

Cost:  BV:

**CF & ARMOR**

Hex	CF	Armor
101	65	64
107	65	64
301	65	64
301	75	0
401	75	0
501	75	0
601	75	0
701	75	0
801	75	0
901	75	0
1007	150	0
206	150	0

**Key**  
Turnout  
Solid Rock  
Elevator  
Mech Bay (2 Levels)  
Vehicle Bay (1 Level)  
Door

**CREW DATA**  
Crew:  Gunnery Skill:

© 2008 WizKids, Inc. Classic BattleTech, Mech and BattleMech are trademarks of WizKids, Inc. All rights reserved. Permission to photocopy for personal use.

CASTLES BRIAN RECORD SHEET

- The red hexes on levels -2 to -1 and levels 2 to 3 indicate the location of multi-hex hangars used to house vehicles or Mechs. These 2-level structures are built as Hardened hangars, with a CF of 75 and no armor, which gives them enough internal tonnage capacity to contain up to 3 Mech cubicles (or 9 light vehicle cubicles) each.
- The blue hexes on levels -2 and 2 are gun emplacements built in the same fashion as the medium "Hex F" guns on the surface. As they stand only 1 level high, these turreted weapon arrays do not effectively exist on levels -1 and 3, unlike the hangars.

The above represents the layout of a sample Castles Brian—at least in part. Deeper, more varied subsurface designs could add secondary communications and command centers, more barracks and infantry space below ground, or even capital scale weaponry on the surface. Some could even include semi-subsurface design features, such as continuing the surface control tower into the mountain itself, or the use of tunnels instead of open-space construction to connect the subsurface buildings. After all, the particular needs and features of the local terrain often affect how a base is laid out on or beneath it; the variety possible is limited only by the designer's imagination.



# BLOODY DIVIDENDS

RANDALL N. BILLS

**STARCORP FACILITY, IVANOGRAD  
EMRIS IV, THE PROTECTORATE  
FREE WORLDS LEAGUE  
5 MARCH 3068**

The wreath of smoke rose languidly before shredding under the force of the slow-moving ceiling fan. Leo Terajima took another long pull from the imported Vanra cigar, the unique taste from that world a delightful spark against the dreariness of his office despite the rosewood desk and plush furnishings. As manager of the StarCorp facility on Emris IV, Leo was entitled to such luxuries, especially with the success of his division during his tenure. Yet it wasn't enough. It was never enough and that left the furnishings dull, as though filtered into insignificance by his ambitions. No, only his Vanra cigars and wine (especially the delicate plum wines shipped once a year from Mandrinn Trenton Volgers) were the only luxuries he truly enjoyed.

"Is this accurate? Have we verified it?" Leo said between teeth tightly gripped around the cigar, eyes scraping across the data cube on his desk.

The head of his Intel division remained stock still, his gaze finding something of interest behind Leo. "Yes."

"How the hell did they get almost a year's lead on us?"

"Unknown."

Leo sighed, his left hand making a quick drum roll on the smooth wood of the desk. "So it would seem our nascent relationship with Hachiman Taro Enterprises is already paying off. Who knew that fat Buddha Chandy would pay such interesting dividends so quickly? If only our own intel was as good."

"Yes." Not a flicker at the subtle rebuke.

On the verge of asking another rhetorical question, Leo sighed heavily, knowing he wouldn't get a satisfactory answer out of the man. He'd thought of replacing him several times for such reticence, but knew of no one as qualified. Though after this setback...

He took another drag until his suit stretched against his expanding chest and held it as he contemplated. The interconnected skein of mammoth, interstellar companies, their subsidiaries and the loyalties of the men and woman like himself that bound them as they crisscrossed Marik space and beyond flowed smoothly through his mind's eye. More importantly, the chinks in the armor of such loyalties played out like tweezers plucking and picking at the web, showcasing weak points. Areas where an astute man could take advantage. And he was a very astute man.

He finally blew out a long stream of smoke. "So they're going to get their mobile air base into operation before us," he said, more to voice his thoughts—which aided problem solving—than out of an expectation of an answer. "And since they're the 800 kilogram gorilla, some governor or viscount is going to gobble it up despite the obscene price tag. Which means they'll have stolen at least a year on us in the marketplace. And if that's not bad enough, they'll be able to offer discounts and upgrades to eliminate any defects in their prototype while we're just getting ours to market. And if nothing goes too badly during such a live-testing phase, it could potentially spark interest directly with the League High Command. And if they land a military contract for their mobile base..."

"Yes. We'll be completely shut out."

"Considering the time and investment, this could be catastrophic. Joss and Amanda would like nothing better than to knock me down a peg or two. And since I pushed this forward after Volgers told me I'd be high and dry if the project failed, the waters will be cleared for the bloodletting."

"Your counterparts in the Alliance and Suns would be ... diligent in taking you to task over such a failure."

"Counterparts. Ha! They're not worthy to lick my boots. Just because they can't handle my success..." He waved the cigar again. "Doesn't matter. We've got to stop IrTech and that means we've got to do something. Something drastic."

For the first time since entering the room, the other man's features changed, twisting slightly with disbelief, brown eyes finding Leo's blue ones. "You aren't seriously considering a direct approach? Against Irian itself? It'd be suicide."

Scorn twisted Leo's features while he waved the cigar to dismiss such ludicrousness. "Of course it'd be suicide. A direct move in their backyard? Might as well go metal tasting to find which high-caliber barrel in the mouth is best. No, I've got something much better. Something more ... appropriate."

"And clean?" the other man asked, almost pleading now.

A smirk curled Leo's lips. "Our hands will be clean as the first snows of winter." As he took another pull to savor the flavor, he amended his previous thought. Better than his cigars and wine, he took true pleasure in taking down an enemy and walking away clean.

**IMB SYSTEMS FACILITY  
CARBONIS, DUCHY OF ORLOFF  
FREE WORLDS LEAGUE  
27 AUGUST 3068**

Trevor Jacks walked as calmly as he could through the IMB Systems Facility, nodding and trading words with his co-workers like an automaton. He nervously adjusted his glasses, then snatched away his hand as though the metal were hot. Too many of them knew that telltale. He smoothed away an invisible smudge from his white lab coat and kept moving.

I know exactly where I'm going. I'm supposed to be going this way and no one will wonder why I'm going this way. Just look the other way. Just look the other way.

Unlike his wife, he'd never believed in such nonsense as extrasensory perception, clairvoyance and other fantasies of lesser-minded individuals. Yet now every ounce of will pushed against his thoughts as though to make them incarnate; a force to safeguard his journey. However, his mind started to betray him as it wound down the path so well trodden in the last two weeks it must be compacted down to ferrocrete by now.

It started so innocently. Just a drink at a bar and a friend to talk to. Someone that didn't burn incense until it clogged the throat and inflamed the sinuses, that didn't move his favorite chair in the living room every other Thursday to maximize the flow of *chi*. Someone to just share a laugh with and unbutton his top shirt button around. He never imagined it would go as far as it did. Never imagined someone like her would be interested in someone like him. Never conceived she could possibly be so young, not with a body like hers.

Or that the holo-vid that arrived on his desk two weeks ago could be so horrifying to watch.



He almost stumbled as he came into view of the security check point, a bead of sweat streaking down his face. He surreptitiously blotted it away while he kept moving, smiling wanly at the guard, flashing a security pass, moving through the detectors and retinal scans and finally passing into the most secure part of IrTech's IMB Systems facility, where the most sensitive electronic systems and patent pending processes were kept. He knew he had to be careful. Knew that this section of the building was under tight control; so tight that even the mainframes were isolated.

But he did need to check on the experiment he was supervising, right? He did that twice a week. That he'd just been there yesterday wasn't that unusual, right?

He absentmindedly patted the data cube in his pocket. That it contained a code that would wend its way through the network in this sector to set off the experimental electro-magnetic pulse device in an adjacent lab would never be discovered. After the EMP was detonated, every electronic device in the entire facility would be fried, including everything in the warehouse. Millions of M-bills of IrTech inventory alone lost, much less the destruction of the facility components.

But that would satisfy the monster who'd sent the holoivid. And he'd be safe, as the pulse would fry any ability to trace the malfunction of the EMP device back to the code originating from his computer terminal.

His face twisted into an approximation of a real smile as he neared the objective, hope surfacing. No one would ever find out. Not about this, not about the other thing.

No one.

**EXETER ORGANIZATION WAREHOUSE  
KEYSTONE, MARIK COMMONWEALTH  
FREE WORLDS LEAGUE  
1 DECEMBER 3068**

"You got that invoice?" Julia Withers asked, yawning. Third all-night shift in a row and she just wasn't as young as she used to be. She wouldn't let Karly talk her into another party on her day off, that was for sure. A whole day of sleep was what she needed.

The section chief of the warehouse (Tristan?) stomped up, eyes flashing as he looked her up and down as though he wanted to tear her a new one. Spit to the side. "Course I do."

She grimaced at the disgusting mannerism. Despite the cacophony—including the thrum of the massive tug's engine at her back and the thudding vibrations of a towering SC *PowerMan* LoaderMech as it stomped by a mere fifty meters distant—that required more lip reading than hearing, she still caught the edge of his distaste to match the spittle. Breathed deeply to shrug it away.

"Just seems odd," she continued, trying for some civil conversation. "This large a shipment of communications gear? To IrTech of all places? Aren't they your competition?"

"Do I look like I care?"

"Um, no," she said, trying and failing to hide another yawn behind her noteputer.

The other man grimaced again and mumbled something she couldn't quite catch, though from her previous encounters she was sure she didn't want to know. "It's easy, tugger. You take that tug of yours and you drag all the container shipments we've already prepared for

you out to Port 12. There you'll find a nice big DropShip where you're gonna load it. And then you walk away, as usual. Or are you too tired for that?"

She bit her lip, knowing she was already in hot water with her boss. Getting another demerit for chewing out a customer as valuable as Exeter would get her canned quicker than she was gonna fall asleep tonight.

She shrugged, gritting teeth against her rebellious tongue, and stabbed at her machine to make a connection to the man's noteputer. The pugnacious beep of the thing at finding everything in order almost undid her determination, but she held on by her fingernails.

"Everything looks in order," she said and walked back toward her tug. Pissant little man. She yawned again, ears popping and jaw creaking with the size of it. Just a few more hours.



Tristan watched the tramp leave. Whore. He knew her type and he spit once more to emphasize it.

He turned and moved back into the bowels of the warehouse, a sneer of satisfaction blooming as he scratched at his neck and readjusted his hard hat. He'd been working on his plans for a year. The defects would never be found. Purchasing outside electronics meant they'd put the system through a triple check. But they wouldn't find anything. They'd never trace it back to Exeter. Those defects would eventually put a hurt on, no doubt about it. He looked around at the faces he'd known for twenty years and despite bitterness was proud they wouldn't get hurt.

But after watching the Exeter he'd known and loved vanish, he simply couldn't stand by any longer. Yet all this time he thought it was Earthwerks that would receive his ire. Earthwerks that was responsible for turning Exeter into a puppet, controlled behind the scenes, monies funneled off every which way and employees left high and dry. The information the man delivered to his home had been shocking and eye-opening. IrTech. IrTech was behind it all. And now, out of the blue, was his chance to strike back at them in his own way.

He spit again, this time in satisfaction. Even if they somehow managed to trace it back, the nice sum of money the man had gifted him ensured he'd be long, long gone by then.

**SOAPSTONE MOUNTAIN  
IRIAN, FREE WORLDS LEAGUE  
7 FEBRUARY 3070**

The behemoth squatted in the air like a hippopotamus attempting to fly.

Charlie's hands and feet danced the balance between the cyclic, the collective and the pedals as he kept the Skye Eye News Helicopter motionless in the early dawn air while James fiddled with the various cameras pegged on the flying monstrosity. He casually checked the radar screen to make sure he maintained proper distance from that thing, as well as the host of other similar helicopters, buzzing around the flying contraption like flies around an uncaring moose.

The snicker slipped out.

"You too?" James said, voice spilling into Charlie's headset.



"Good God, are you kidding me!? Look at that thing! This is what, the fourth flight? And I still can't get over it. How can something that large fly?"

"I know, I know. I've been around Dawn Treader and Cloud Nine carrier airships. They were massive. But this ... wallows through the air like a pregnant sow through monsoon season swamp grass."

"You said it. Can't really think this is gonna be useful?"

Charlie could almost hear the shrug. "That's what they say," James said. "But hey, I'm just paid to film it for posterity. Whether it'll actually be worth the money someone's gonna have to pay... who knows."

"Pay! I wouldn't pay a ten cents for it, much less an eagle. Good God, man. What scientist dreamed this thing up? If ever I've seen a case of 'mad scientist,' this is it. Someone with too much imagination, not enough sense and too many connections for someone to slap him silly."

They both shared a hard laugh that actually sent a twitch through the smooth hover of the VTOL. Charlie squeezed his eyes shut several times to dump the tears from the laugh. Abruptly his forehead creased in confusion. What the heck? That wasn't in the flight plan they'd been given. With a flick of his eye at the zoom icon on his heads-up display, the image projected onto his helmet's screen leaped forward as the monolithic airship continued to slew further left, now starting to lose altitude.

"What the hell?" James said, catching the same view.

"I don't know." He quickly tapped on the command frequency and his head jerked back under the onslaught of a babble of a dozen voices. Though he wanted to break in, he realized he'd be lost in the din. Instead he tried the frequency reserved for a direct link between him and Air Base 1, only to find static.

Despite his ridicule of the aberration, dozens of people crewed it, including many he knew. Horror leached his brain of activity beyond the subconscious flow of neurons and muscles keeping the VTOL level; hated himself for thinking it, he knew this would make a great human interest story ... provided he was ever allowed to tell it.

Now the contraption banked completely off any axis remotely level and slewed toward the harsh mountain peak with ever-increasing speed. He cried out as Air Base 1 slammed into the mountainside and began crumpling like a giant tin can. Its surface structure pulverized and rained across the mountain top as massive rents hove through hundred-meter sections of the ship. Gases exploded outward under the compacting pressure, gas bags bursting, hurtling entire metal sections of skin kilometers into the air and so hard into the mountainside it would take weeks to excavate. Several internal bags remained airborne, torn apart from the superstructure, but leaking gas rapidly as they spun crazily through the air, passing in and out of sight through the titanic dust cloud blooming into the darkening sky.

He never saw a single escape pod.

## **LOCATION UNKNOWN 27 MAY 3071**

Peter Abdulsattah found his master at his normal haunt. He carefully entered the berth, making sure none of the floating data cubes or errant noteputers slipped out the hatch as he dogged it closed. He swam further into the stateroom before attaching velcro-slipped feet silently to the wall and hunkered down, waiting to be noticed. He knew such clutter on a DropShip waiting at a jump point seemed needless, even careless. Yet his master

found patterns in all things and such was his way; he knew an aide would arrive before jump initiation to secure the massive data archives compiled across a lifetime.

His over-large master set down the noteputer in his hands, gecko tape securing it to the desk, and glanced up, jowls sloshing in the microgravity.

"Honored one, I bring news," Peter said.

"Speak." Chandrasekhar Kurita spoke softly, voice at odds with the large bald head and rotund body. There was a reason he was nicknamed Uncle Chandy, though Peter would die before uttering such words.

"It would seem your efforts have proven successful."

"Hughes is removed from power?"

"Hai. The fiasco of the destruction of Air Base 1 allowed Chris Blocher to force a vote of no confidence against the CEO."

"His non-ferrous has been particularly profitable the last several years."

"Hai. He's honed such clout and when the opportunity arose, easily slipped the blade between the old man's ribs when he least expected it."

"No," Chandy said, raising a hand. "It was expected at all times. Blocher has been a thorn in Hughes' side for some time. If he was not grooming a successor, he never would've allowed the man to retain power."

Peter nodded at the plainness of the argument. "There have been casualties along the way."

"Yes?"

"It would seem that despite the best care taken, IrTech managed to trace the event all the way back to CEO Terajima of StarCorp on Emris IV. He's recently gone missing. I doubt very much anyone will see him again."

"Very efficient of them."

Peter raised an eyebrow. "I doubt very highly that IrTech, despite their prowess, could've made such a connection without our invisible aid."

"True. Too true."

"But why, honored, why? Isn't StarCorp an ally now?"

Chandrasekhar once more steepled his fingers. His large face, full-lipped smile and lazy eye, not to mention sumptuous clothing, often led people to the wrong conclusion. A purposeful deflection that perfectly encapsulated the genius of Peter's master.

"Of course they're an ally. But any ally must be managed. Controlled. Yet never seeing the steel underneath the silk ... until it is too late. Terajima was too dedicated to complete control of the StarCorp satellite divisions. Such a unification of authority would cause...difficulties when playing the various division heads off of one another to achieve our goals."

Peter nodded, quickly following the path illuminated by his master. "Not to mention that the fallout of both a change in IrTech leadership and a strike at the highest levels of IrTech by an arch-rival leaves numerous cracks in the façade."

Chandrasekhar nodded sagely. "Exactly. A hostile takeover of IrTech's leadership would certainly cause enough confusion for us to exploit. But IrTech has its own masters and we must be sure to distract all eyes. The placement of StarCorp in the path of their inquiry will provide such a distraction. We'll now be in a better position than ever for infiltrating IrTech."

"And ultimately their Word of Blake masters."

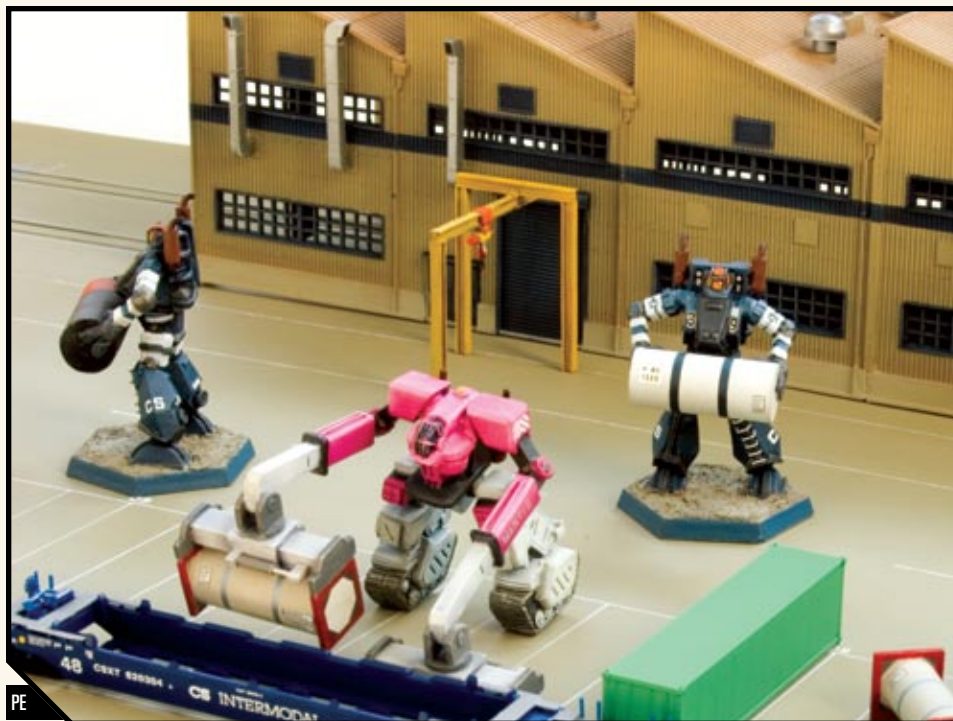

PE

*IndustrialMechs hurry to unload war supplies brought in by rail.*

The following rules cover the specifics of movement and combat for the advanced-rules Support Vehicles, as well as Mobile Structures, in this rulebook. Unless stated otherwise, these units follow all the standard/advanced rules for movement and combat discussed in *Total Warfare* (or in this volume, as appropriate).

Rules for construction of these units appear in the *Advanced Support Vehicle Construction Rules* section (see p. 236).

## SATELLITES

Satellites are Space Stations' smaller (and often unmanned) kin. Unlike Space Stations, which can be located anywhere in a system, Satellites are exclusively placed in orbit around other planetary bodies (usually a planet or a moon, though potentially a large asteroid or a star) and are extremely reliant on accurately plotted orbits and computer controls.

The following rules apply to Satellites.

### MOVEMENT (OUTSIDE OF GAME PLAY)

The following movement rules generally fall outside of the scope of a standard scenario.

A Satellite can be placed in a low-altitude or geo-synchronous orbit (more exotic orbits, like Molnyia orbits, are beyond the scope of these rules and are left as an exercise in orbital mechanics between the players). A low altitude orbit (polar or standard) takes 1.5 to 2.5 hours depending on the planet, during which a Satellite located a few hundred kilometers from the surface constantly travels over either the same band of terrain or, if in a polar low altitude orbit, slowly encompasses the entire planet but only occasionally passes over the same point on the ground.

A geo-synchronous orbit keeps a Satellite over the same equatorial location continuously but at much higher altitude—the precise distance depends on the world, but on Terra it is just under 36,000 km.

Satellites require no Control Rolls to maintain their orbit. However, when initially placed in orbit, or when its orbit is changed, the player controlling a Satellite must make a 2D6 roll against a Target Number 8. Failure by an MoF of 1 or 2 doubles the time required to change orbits. An MoF of 3 to 5 causes the Satellite's orbit to decay in 2D10 weeks. An MoF of 6 or more immediately sends the Satellite spiraling into the body it orbits. Note that fission- and solar-powered satellites may not change orbits sufficiently to move between the different types of orbits (low altitude (polar) or low altitude (standard), geosynchronous, Molnyia, and so on), as these require far more fuel than the satellites carry.

A decaying orbit destroys the Satellite, either through impact with the surface or burning up as it reenters the atmosphere. If the error is caught in time, the situation can be rectified via a Control Roll by a remote operator (though the orbit correction process takes a day), but the difficulty depends on the level of failure of the previous 2D6 roll; apply the previous MoF as a penalty. Multiple attempts can be made until the Satellite falls out of orbit.

### MOVEMENT (DURING GAME PLAY)

The following movement rules provide for limited movement of a Satellite within a standard scenario.

Satellites are essentially static in aerospace combat. Their station-keeping drives lack the power to provide even rudimentary changes in velocity within the context of a game; any repositioning of a Satellite requires hours if not days to achieve, the drive generating only around 1/40 of a G (1/20 of a thrust point).



While Satellites mount attitude jets, they are very weak. A Satellite's attitude jets provide .2 thrust. A Satellite can accumulate thrust across several turns to make a facing change. Once a Satellite has accumulated 1 Thrust Point using its attitude jets, it must make a facing change.

Military Satellites mount more robust attitude jets and can change 1 hexside per turn.

**Thrusters:** Thruster critical hits (see p. 240, *TW*) on a Satellite are treated as a standard critical hit; i.e. the cost to turn in that direction is increased by 1. As such, a civilian satellite that has taken a single left thruster critical hit would require ten turns to build up enough thrust ( $.2 \times 10 = 2$ ) to make a left facing change.

## RAIL

The following rules apply to Rail Support Vehicles. All the same rules that apply to Large Support Vehicles as described in the *Combat* section of *Total Warfare* (starting on p. 98, *TW*), as well as Tractors and Trailers as described in *Support Vehicles* (see p. 205, *TW*) also apply to Large Rail Support Vehicles.

### MOVEMENT

For Rail Support Vehicles to move on a mapsheet, they must move through a continuous, unbroken line of rail hexes (see *Rails*, p. 51). Before play begins, players should determine which hexes on the playing area contain rails.

Unlike most vehicles, Rail Support Vehicles take time to reach speed or slow down. Each turn, a train can increase or reduce its speed (up to the unit's maximum current MP limit). Small and Medium Rail Support Vehicles can increase or decrease speed by 2 MP per turn, while Large Rail Support Vehicles can only alter speed by 1 MP per turn. If a Rail Support Vehicle is rendered immobile by damage, it does not come to a sudden halt (though automatic brakes fall into place), but rather it decelerates by 2 MP per turn (Small and Medium) or 1 MP per turn (Large) until its speed drops to zero.

If a Rail Support Vehicle consists of a mix of different size classes, then the speed change for the largest-class Tractor and/or Trailer in the Rail Support Vehicle is used (for example, a Medium Tractor hauling a Large Trailer can only change speed by 1 MP per turn).

### Detaching Tractor/Trailers

If the Trailer(s) that a player has announced he is detaching are part of a rail "train," and the detached section does not include a functioning Tractor of its own, the Trailer(s) slow to a stop as indicated above.

**Immobile Targets:** Once the Tractor/Trailers have come to a complete stop, they are considered immobile targets.

### Collisions

A unit that has not yet moved during the current Movement Phase can attempt to dodge a train passing through the hex occupied by the unit. In order to get out of the way, the player controlling the target unit must make a successful Piloting/Driving Skill Roll (or Gunnery Skill, if no Piloting Skill exists) just before the train enters the target's hex. A successful roll means the target unit may make its entire movement imme-

diately, before the rail unit continues its movement. Failure means the target remains in its hex (though a failed roll does not cause the target unit to fall). Units moved in this way have expended their movement (by walking/cruising) and may not move again later in the Movement Phase. A failed roll means the unit gets rammed by the train.

A Rail Support Vehicle entering the hex of a Large Ground Vehicle, an immobile unit, or any grounded aerospace units or grounded VTOL/WiGEs, automatically rams such units.

Unlike other ground vehicles, Rail Support Vehicles cannot intentionally make a ramming attack. If a unit is rammed by a Rail Support Vehicle, damage is applied as for a successful Charge Attack (see p. 148, *TW*), with the following modifications: damage is equal to the current armor of the location which struck the target, plus that location's current internal structure, divided by 10, multiplied by the number of unspent MP in a turn, rounding down (the MP to enter the hex where the ram occurs is considered spent in this calculation). Damage to the Tractor/Trailer is applied normally, per the standard Charge Attack rules; if it strikes an unusual target (see *Unusual Targets*, p. 148, *TW*) the damage to the Tractor/Trailer is based on the weight of the vehicle only and not the entire train.

If ramming occurs, and the weight of the rammed unit is equal to or greater than the weight of the Tractor only, the controlling player of the train makes an immediate Piloting Skill Roll; a failure means the train has derailed, as though the rails in that hex were destroyed (see *Derailed Vehicles*, below). If the weight of the first three Tractors/Trailers is greater than the weight of the target unit, the target unit is randomly displaced to the right or left of the hex it occupied (unlike standard displacement, it is not displaced in the direction of the ram). If the unit cannot legally enter any hex to the right or left of the hex it occupied, it is considered destroyed.

If the weight of the target unit is greater than the weight of the first three Tractors/Trailers, the target unit is not displaced. Instead, the train derails in the last hex it occupied before it would have entered the hex occupied by the unit that was not displaced; the exception to this rule is Large Tractor/Trailers (see *Derailed Vehicles Due to Movement* below).

**Large Craft:** A Large Craft, regardless of the weight of a train, will never be displaced.

**Infantry:** Infantry, even if they occupy a hex entered by a moving train, can never be rammed by it; if a stacking violation occurs, simply move the infantry to the most appropriate adjacent hex. If an infantry unit must be moved to an adjacent hex and no legal adjacent hex is available, the infantry unit is destroyed.

### Derailed Vehicles Due to Movement

A Rail Support Vehicle entering a hex where the rails have been destroyed derails and skids; except as noted below, follow all the standard rules for a skidding 'Mech (trains are not treated as a vehicle when skidding; see p. 62, *TW*).

A Tractor/Trailer skids a number of hexes equal to its unspent MP at the start of the skid, divided by 2 (round up). For example, a Tractor starts the turn with a speed of 6 MP, and the controlling player does not accelerate or decelerate, meaning it must enter 6 hexes during its movement. If the unit enters 3 hexes, thus having spent 3 MP) and on the third hex it derails, it will skid for 2 hexes [ $3 \text{ hexes (MP remaining)} / 2 = 1.5$ , rounding up to 2].

INTRODUCTION

ADVANCED  
GROUND MOVEMENT

ADVANCED  
COMBAT

ADVANCED  
BUILDINGS

ADVANCED  
SUPPORT  
VEHICLES

GENERAL  
RULES

ADVANCED  
SUPPORT VEHICLE  
CONSTRUCTION

ADVANCED  
WEAPONS  
AND EQUIPMENT

INDEX

RECORD SHEETS



If a Tractor/Trailer derails, all the Tractors/Trailers behind the derailing one will automatically start to brake, decelerating by 2 MP per hex (this is in addition to the 1 MP cost for entering a hex) until their speed drops to zero and/or the next Tractor/Trailer enters the hex that will cause it to derail. Any Tractor/Trailers that cannot slow quickly enough and enter the hex where the rails are destroyed automatically derail and skid also, as described above.

A skidding Tractor/Trailer may accidentally collide with any unit and/or obstacle in a hex it enters while skidding, per the standard skidding rules (see *Collisions*, p. 62, *TW*). While the skidding of each Tractor/Trailer in a train is resolved separately, if a unit and/or obstacle is struck, the damage is applied as noted under *Collisions*, as noted above.

Additionally, because of its massive size and momentum, a Large Tractor/Trailer that derails and skids does not automatically stop if it successfully hits a target unit and that unit is not destroyed, or if the weight of the target unit is more than the weight of the entire train (see above), or if it strikes an obstacle. Small- and Medium-sized Tractors/Trailers do, however, follow the standard skidding rules and their movement would end under those conditions. If a Large Tractor/Trailer skids and encounters any of the three previously described situations as it enters a hex, then the controlling player should look at the hex to the right and to the left of the hex the unit cannot enter to see if the Tractor/Trailer can legally skid into those hexes. If both are available, randomly determine which hex it skids into; if only one is available, the Tractor/Trailer automatically skids into the available hex. In both instances, the Tractor/Trailer continues to skid in the direction of the original skid; this means a Tractor/Trailer could potentially charge multiple units and/or the same unit multiple times (in the case of a multi-hex unit). If both of the hexes to the right and left of the hex the unit cannot enter are illegal to enter, then the Large Tractor/Trailer remains in its current hex and the skid is finished.

A derailed train automatically destroys the rails in any rail hex it enters, and the hex is reduced to a rough hex (unless there are derailed Tractors/Trailers present after the derailing is resolved, in which case it is considered ultra-rough; see below). Additionally, if a derailed and skidding train must remain in its current hex, any rails in that hex are destroyed as well.

Finally, for the ease of game play, stacking limits for derailed trains do not apply. Instead, any number of Tractors/Trailers may end their movement in whatever hexes they skid into. Any hex that contains a derailed Tractor/Trailer is considered an ultra-rough hex, automatically reducing any trees and/or jungle (see p. 31); even if all Tractors/Trailers are destroyed during a derailing, the hex is still considered an ultra-rough hex. Once skidding has been resolved, the hex can also be damaged and reduced just like any other ultra-rough hex (the damage is no longer done to the train, but instead to the ultra-rough hex as a whole).

## CARRYING UNITS

If a Rail Tractor and/or Trailer is built with cubicles allowing it to carry other units (such as aerospace fighters, Small Craft, 'Mechs, vehicles and so on), the mounting and dismounting of such units from a stationary train follows the same rules as for a grounded DropShip (see *Carrying Units*, p. 89, *TW*).

If a Rail Support Vehicle expends MP in the same turn that units are dismounting, only units with Jumping/VTOL MP may disembark; if a unit mounts a Flight Deck, fighters can take off normally (or using VTOL movement), without regard to whether the carrying unit

expended MP or not. Additionally, any such unit (except a fighter taking off from a Flight Deck) expending Jumping MP to dismount must make an immediate Piloting/Driving Skill Roll (Anti-'Mech Skill Roll, in the case of infantry) to avoid falling in the target hex.

If an infantry unit fails this roll, apply a single point of damage to all battle armored troopers, or in the case of conventional infantry, apply a single 5-point Damage Value grouping as though another infantry unit had made a successful attack.

A VTOL Vehicle that fails the Driving Skill Roll automatically crashes in the hex from which it was attempting to take off (see *VTOL and WiGE Vehicle Crashes*, p. 68, *TW*); for the purposes of damage, the VTOL Vehicle is considered to have moved 1 hex and randomly determine the damage location. Infantry expending VTOL MP also crash in the hex from which they were attempting to take off, applying damage as described above for infantry using jumping MP.

In all instances, whether a jumping unit failing a PSR and falling in the target hex or a unit expending VTOL MP failing the PSR and crashing in the hex they were attempting to take off from, the unit's movement is over.

**Units Carried Externally:** Units carried by a Tractor/Trailer are in transport bays; even on a flatbed car, the unit is considered completely enclosed by the transport bay. Infantry units are the exception to this rule.

When an infantry unit mounts a Tractor/Trailer, the controlling player can choose to have the unit enter the Tractor/Trailer (that is, become cargo) or move to the top of the Tractor/Trailer (meaning they are on the roof); if the Trailer is a flat car, the infantry is "in the open," riding on top of the rail vehicle. Additionally, during any subsequent Movement Phase the controlling player can move the infantry unit from the roof of one Tractor/Trailer to the roof of another (regardless of the size of the Tractors/Trailers involved, the infantry can only move one unit), or to the transport bay (to become cargo) of the unit they currently occupy, or from the transport bay to the roof of the Tractor/Trailer. Regardless of MP available, the infantry unit is considered to have used all its MP when it makes any such transition. If an infantry unit is moved off of the Tractor/Trailer, use the rules above, directly under *Carrying Units*.

Roof stacking limits per side are as follows: 1 infantry unit on a Small Tractor/Trailer, 2 infantry units on a Medium and 3 infantry units on a Large Tractor/Trailer.

In addition, any infantry units carried externally are counted as an individual unit(s) for Initiative purposes (unlike standard rules concerning carried units, which are not counted until the turn following the one in which they dismount). However, they are not counted toward standard stacking limits within a hex.

The only exception to this infantry rule applies to motorized and mechanized conventional infantry, which cannot be on the roof of a Tractor/Trailer, but can be outside a transport bay on a flat car (see p. 247). Motorized or mechanized infantry "in the open" on a flat car cannot be moved to another Tractor/Trailer like other infantry; they must dismount the train and then mount again to move to another Tractor/Trailer. The stacking limits for all types of infantry on a flat car are identical to the roof stacking limits noted above.

**Derail:** If a Tractor/Trailer derails and is not destroyed, apply two 5-point Damage Value groupings to randomly determined locations (for conventional infantry, the damage is applied as though another infantry unit had made a successful attack). The units may dismount (provided they can do so legally) at the end of the Movement Phase following the turn in which the derailing occurred.



**Destruction:** If a Tractor/Trailer is destroyed, use the rules for destruction of a DropShip carrying units (see *Destruction*, p. 90, TW) to determine if any units survive.

All cargo on a destroyed Tractor/Trailer is automatically considered destroyed.

If a Rail Tractor and/or Trailer is displaced into a hex that is 2 or more levels lower than the adjacent hex, resulting in an accidental fall, all carried units are automatically destroyed.

*In the Derailing diagram below, an Adelante Passenger/Cargo Train consisting of a Tractor and four Trailers (2 Configuration Bs, a C and a D; for this example we'll simply call them trailers A, B, C and D) is moving with a current speed of 9 on the Open Terrain #1 map. The players determined before the start of the game which hexes contain rails. The standard movement of the Adelante Tractor is 12/18, but the Trailers it is hauling reduce its current movement to 6/9. At the start of the turn, the Adelante Tractor occupies Hex TA, while Trailers A and B, as Medium-sized Trailers, occupy Hex TB. Trailers C and D (also Medium-sized) occupy Hex TC.*

*During the Movement Phase (Aerospace) of the previous turn, the opponent successfully landed a Manatee-class DropShip in Hex DA (the controlling player of the DropShip determines that the ship's right side is lined up with the oncoming train; see p. 250, TW). At the start of the Movement Phase (Ground) of the next turn, the Adelante will be unable to slow quickly enough and so will automatically collide with the DropShip. If using the Terrain*

*Factor Rules (see p. 64), the landing DropShip would have destroyed the rails, so even if it landed and managed to take off before a train arrived, the destroyed rails would cause the Adelante to derail.*

*Even though the Adelante is going to collide with the ship, the train's controlling player does what he can. Because the Adelante Tractor is a Large-sized vehicle, he can only decrease its speed by 1 MP per turn (see p. 149), which he does at the start of the turn, and then he moves it forward 1 hex. The train then spends another MP to attempt to enter the DropShip hex, which means that as the train rams the DropShip its current MP left unspent is 6.*

*Regardless of the combined weight of the Tractor and the first and second Trailers, the train cannot displace the DropShip as it is a Large Craft. Ramming for each Tractor/Trailer is determined separately, and so the controlling player starts with the Tractor.*

*The player determines the damage caused by the Tractor ramming the DropShip and arrives at 60 points of damage [60 (current front location internal structure) + 40 (current front location armor) = 100 / 10 = 10 x 6 (MP unspent in the turn) = 60]. Normally this damage would be divided into 5-point Damage Value groupings, but against the DropShip it is simply applied as a single block of damage to the right side, leaving the DropShip with 10 points of armor. As the Damage Value of the attack exceeds the Damage Threshold of the armor in that location, the controlling player of the DropShip will need to make a Determining Critical Hits roll.*

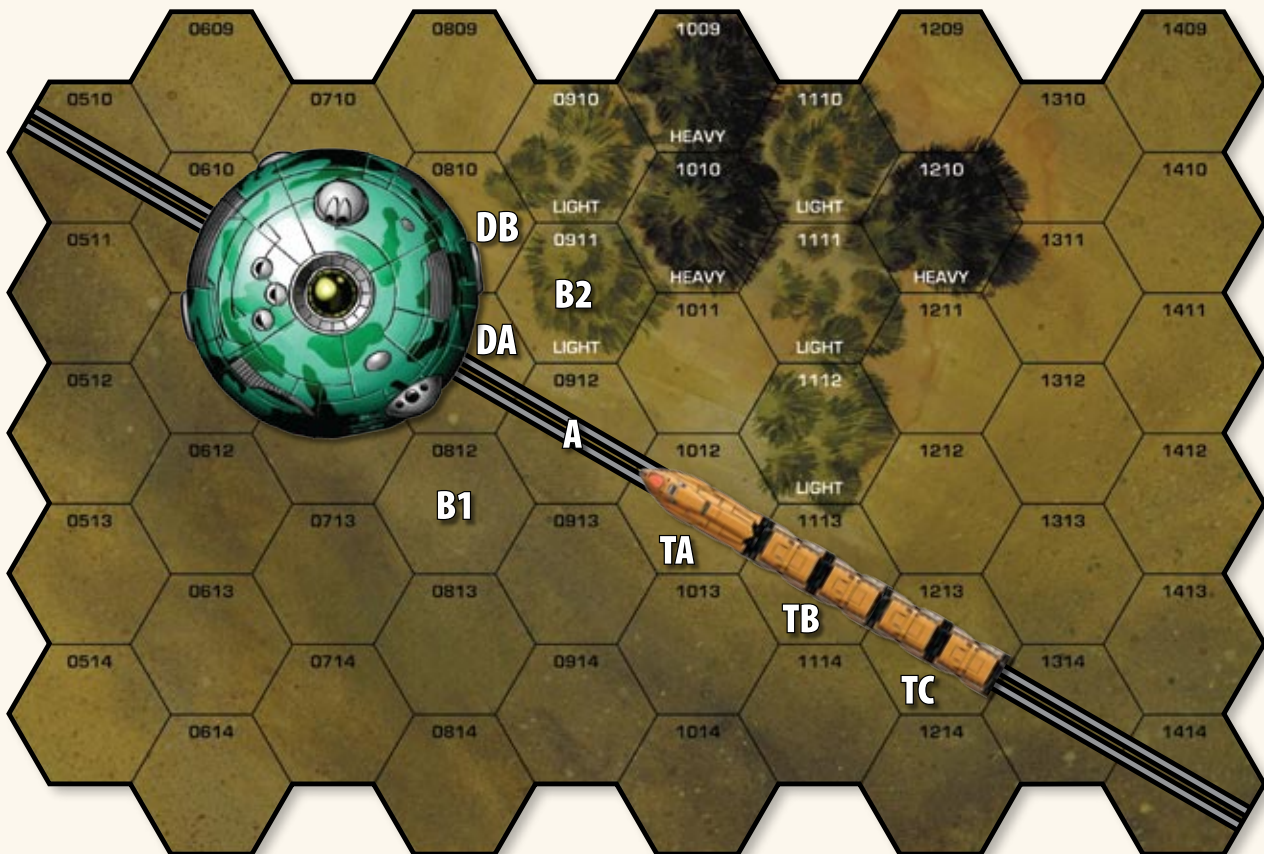

• DERAILING DIAGRAM •

INTRODUCTION

ADVANCED  
GROUND MOVEMENT

ADVANCED  
COMBAT

ADVANCED  
BUILDINGS

ADVANCED  
SUPPORT  
VEHICLES

GENERAL  
RULES

ADVANCED  
SUPPORT VEHICLE  
CONSTRUCTION

ADVANCED  
WEAPONS  
AND EQUIPMENT

INDEX

RECORD SHEETS



Because the target is a DropShip, damage to the Tractor is applied based on the Tractor's weight, which equals 60 points of damage  $[600 \text{ (Tractor tonnage)} / 10 = 60]$ . The player rolls 2D6 on the front column of the Large Ground Support Vehicle Hit Location Table (see p. 206, TW), with a result of 6; all the damage is applied to the front, which strips it bare of armor and inflicts 20 points of damage to the internal structure. The internal structure at the front of the Tractor has 40 points remaining. In addition to the standard Determining Critical Hits roll that must be made for damaging the internal structure, a penetrating critical hit must also be rolled because the Damage Value of the collision exceeded the Tractor's BAR of 7.

Next, the Tractor automatically derails and will skid. Upon the attempt to enter Hex DA occupied by the DropShip, the Tractor had 6 unspent MP, meaning it will skid for 3 hexes  $[6 \text{ (MP remaining)} / 2]$ . As the Manatee ship will not be displaced, the derail actually occurs in Hex A, meaning the rails in Hex A are destroyed. Normally a skidding unit, if it charges an obstacle, would end its movement in Hex A. However, the Adelante Tractor is a Large-sized unit, and so the controlling player looks at Hexes B1 and B2 and determines that both of them are legal to enter. He randomly determines that a roll of 1-3 will be a skid into B1, while a roll of 4-6 will be a skid into B2; the 1D6 die roll result is a 5, and so the first hex of the three-hex skid will be into B2. However, as that hex is light woods, 1 hex is removed from the total number of hexes in the skid (see Terrain, p. 63, TW). The damage applied to the skidding Tractor is just like a 'Mech skidding: the unit's weight, divided by 10 and then halved, resulting in 30 points of damage  $[600 \text{ (weight of Adelante Tractor)} / 10 = 60 / 2 = 30]$ . The controlling player once again rolls for the damage location; a result of a 3 means the 30 points of damage is applied to the right side. Though armor still remains, once again the Damage Value is higher than the BAR, and so another penetrating critical hit must be rolled.

With only one more hex to skid into, the controlling player of the Tractor must continue the skid in its original direction, meaning that the Tractor will once again ram the DropShip as it attempts to enter Hex DB. The total damage is 24  $[40 \text{ (current front location internal structure)} + 0 \text{ (current front location armor)} = 40 / 10 = 4 \times 6 \text{ (MP unspent in the turn)} = 24]$ . This strips the last 10 points of armor away, leaving 14 points to deal with. As per standard rules, the damage is divided in half and applied to the structural integrity, leaving 3 SI. Because the hit exceeds the vessel's Damage Threshold and SI damage was taken, the controlling player of the DropShip must make two Determining Critical Hits rolls. Furthermore, 60 points of damage is also applied to the Tractor  $[600 \text{ (Tractor tonnage)} / 10 = 60]$ ; the resulting hit location roll of 8 means the damage is applied to the front. As there are only 40 points of internal structure available, this hit depletes that section's internal structure, which destroys the Tractor. This means the player does not need to skid the Tractor into Hex DB. Even though the Tractor was destroyed, B2 is now considered an ultra-rough hex; the light woods are gone.

Next, the player resolves the movement of Trailer A. The Trailer's 6 MP is reduced to 3 as it enters Hex A  $[1 \text{ MP (entering the hex)} + 2 \text{ MP (automatic braking)} = 3 \text{ MP remaining}]$ . Because the rails in Hex A were destroyed when the Tractor derailed there (being unable to legally enter Hex DA), Trailer A automatically derails and will skid for 2 hexes  $[3 \text{ (MP remaining)} / 2 = 1.5, \text{ rounding up to } 2]$ . First, however, the controlling player must

resolve the damage caused by the ramming attack of Trailer A into the DropShip as it attempts to enter Hex DA. He determines that the ram causes 9 points of damage  $[12 \text{ (current front location internal structure)} + 20 \text{ (current front location armor)} = 32 / 10 = 3.2 \times 3 \text{ (MP unspent in the turn)} = 9.2, \text{ rounding to } 9]$ . As only structural integrity remains, that damage is halved, rounded down, which means that only 4 points of damage are applied. However, since there is only 3 points remaining, the DropShip is destroyed! Even a DropShip can't play chicken with a train... or if the player is going to play that game, he should put down a DropShip with a whole lot more armor.

The player still must determine damage to Trailer A, which is 12 points  $[120 \text{ (Trailer weight)} / 10 = 12]$ . The player rolls a 7 on the hit location table and applies the 12 points of damage to the front, leaving him with 8 points of armor; the BAR of 9 on the Trailer means a penetrating critical hit must be rolled. With the DropShip destroyed, the player now must continue the skid of Trailer A. Trailer A will skid into Hex DA, inflicting 6 points of damage  $[120 \text{ (weight of Trailer)} / 10 = 12 / 2 = 6]$ ; with a hit location roll of 7, that damage is applied to the front, reducing the front armor to 2 (no penetrating critical hit is required). The players are using the Battlefield Wreckage rules (see p. 187), and the DropShip hexes are now considered ultra-rough, so that terrain subtracts the number of hexes Trailer A needs to skid down to 0.

Now the player turns to Trailer B. As it is the same size and occupies the same original hex when the derailling occurred as Trailer A, it undergoes all the skidding determined above. However, in addition to the 6 points of skidding damage that must be applied to Trailer B for skidding into Hex DA, Trailer B will automatically charge Trailer A, inflicting 36 points of damage on Trailer A  $[120 \text{ tons (each Trailer)} \times 3 \text{ (number of Trailers)} = 360 \text{ tons} / 10 = 36]$ . The controlling player rolls 2D6 for the hit location, and with a result of 7, applies the damage to the rear. That location has only 19 points of armor and 12 internal structure points, and so can only take 31 points of damage; 36 points means that Trailer A is destroyed. Finally, 12 points of damage (from the ramming attack) is also applied to Trailer B, which will require a penetrating critical hit roll.

Fortunately, the controlling player of the train is luckier with Trailers C and D. As they moved from Hex TC to Hex TB, they expended 3 MP  $[1 \text{ MP (entering the hex)} + 2 \text{ MP (automatic braking)} = 3 \text{ MP remaining}]$ . Then, as they moved from Hex TB to Hex TA, they expended the final 3 MP, leaving Trailers C and D as immobile targets in Hex TA.

Finally, the player needs to determine what happened to the units carried by the train. Trailer A was destroyed (a Configuration B Trailer), and so the controlling player must roll 1D6 for each of the light vehicle and three battle armor units carried by the Trailer to see if they survived (provided they survived any penetrating critical hits). For each unit, on a roll of 1-2, the unit survives; on a roll of 3-6, the unit is destroyed. If any units survived, the controlling player must determine stacking and make sure that no violations occur (see Destruction p. 90, TW).

For Trailer B, the player does not need to determine if the unit was destroyed, but does need to apply two 5-point Damage Value groupings to the light vehicle and three battle armor units in Trailer B (provided they survived any penetrating critical hits). At the end of the Movement Phase in the following turn, the controlling player can dismount the units carried by the derailed Trailer B (provided a hex exists nearby into which they can legally dismount).



## COMBAT

The following additional rules apply to combat for Rail Vehicles.

### Attacks from Infantry Carried Externally

Infantry units carried externally (unlike any other units carried by a Tractor/Trailer) can make all standard weapon attacks. This includes attacks using field guns and field artillery (see p. 311) for motorized and mechanized infantry. All standard rules are used for making any type of weapon attacks, with the following exceptions:

Apply a +1 to-hit modifier to all such attacks.

An infantry unit on a flat car cannot make an attack if the LOS falls across the hexside through which a Tractor/Trailer is connected to another Tractor/Trailer.

### Attacks Against Infantry Carried Externally

Just like mechanized battle armor (see p. 227, *TW*), attacks against infantry carried externally on a Tractor/Trailer cannot be made. Instead, whenever an attack is made against a Tractor/Trailer carrying infantry externally, roll 1D6. On a result of 1–4, the infantry takes no damage; the total Damage Value of the attack is applied to the Tractor/Trailer. On a result of 5–6, the attack strikes the infantry unit; for battle armor, randomly determine which trooper is hit. Any damage remaining (meaning the conventional infantry is destroyed, or the trooper in a battle armor unit is destroyed) is applied to the Tractor/Trailer.



MM

A pirate Scarabus attacks a train in the hopes of securing a prize: Long Tom mobile artillery.

### Derailed Vehicles Due to Damage

If a Tractor/Trailer location is completely destroyed, per standard rules for vehicles, the unit is destroyed. The train behind the destroyed unit is automatically detached from the train in front of the destroyed unit; if any portion of the split train does not contain a Tractor, it will slow to a stop (see *Movement*, p. 149). However, there is a chance the destroyed unit will cause the train behind to derail. The controlling player automatically rolls 2D6. On a result of 8 or better, the Tractor/Trailer immediately following the destroyed unit derails, either in the hex it currently occupies or as it enters a new hex, depending on the size of the Tractors/Trailers involved (see *Derailed Vehicles Due to Movement*, p. 149).

### Area Effect Weapons

Damage from weapons with an area of effect, such as artillery, may affect multiple Tractors/Trailers in a train, depending on the area affected by the artillery as well as whether a Small, Medium or Large Tractor/Trailer is in a hex. For example, a Large Tractor in Hex A has a two Small Trailers following directly behind in Hex B. A Long Tom artillery shell lands in Hex B. Twenty points of damage would be applied to both Small Trailers in Hex B, while 10 points of damage would be applied to the Large Tractor in Hex A.

**Infantry Carried Externally:** Area-effect weapons apply their full damage to any Tractor/Trailers involved, as well as to any infantry units carried externally (see p. 150).

### Swarming Attacks

Enemy infantry units can swarm a Tractor/Trailer using the standard rules for swarming a vehicle. Apply a +1 modifier for every 2 hexes the train entered during the Movement Phase of the current turn; infantry units with VTOL or Jumping MP do not apply this modifier.

A failed swarming attempt automatically inflicts a single 5-point Damage Value grouping; against conventional infantry this is treated as an attack from another infantry unit.

Only externally carried infantry (see p. 150) located on the Tractor/Trailer currently being swarmed by an infantry unit can be used to fight off the swarming attack. If an infantry unit friendly to the Tractor/Trailer is on another Tractor/Trailer, or is inside the Tractor/Trailer that has been successfully swarmed, the controlling player of that friendly infantry unit must make a standard swarming attack for the friendly infantry unit to move onto the swarmed Tractor/Trailer and engage the enemy infantry (see *Mechanized Battle Armor*, p. 222, *TW*).

Note that a Tractor/Trailer cannot make a Driving Skill Roll to attempt to dislodge swarming infantry (see *Vehicles*, p. 222, *TW*).

The stacking limits of a Tractor/Trailer “roof” apply for enemy infantry the same as for friendly: 1 infantry unit on a Small Tractor/Trailer, 2 infantry units on a Medium and 3 infantry units on a Large Tractor/Trailer. This means a total of 2 infantry (one friendly, one enemy) can occupy the roof of a Small Tractor/Trailer, 4 total infantry (two friendly, two enemy) a Medium and 6 total infantry (three friendly, three enemy) a Large Tractor/Trailer.

INTRODUCTION

ADVANCED  
GROUND MOVEMENT

ADVANCED  
COMBAT

ADVANCED  
BUILDINGS

ADVANCED  
SUPPORT  
VEHICLES

GENERAL  
RULES

ADVANCED  
SUPPORT VEHICLE  
CONSTRUCTION

ADVANCED  
WEAPONS  
AND EQUIPMENT

INDEX

RECORD SHEETS



## CHARGING RAIL VEHICLES

Charges against Rail Vehicles are resolved normally, with the following modifications and additions.

If a unit charges a Tractor or Trailer on the side (that is, the charging unit enters on one of the four hexsides that are not the two hexsides via which the train is traveling through the hex), apply a -2 to-hit number. Additionally, after resolving damage, the players should determine if the rail unit derails. If the weight of the charging unit is greater than the combined weight of the target Tractor/Trailer, as well as the weight of the Tractor/Trailer immediately in front of and behind the target (if any), the unit is considered detached at the point where it connects to the rail unit in front and it immediately derails (see *Derailed Vehicles Due to Movement*, p. 149). If the weight of the combined Tractors/Trailers is equal to or greater than the charging unit, the train is not derailed. In all instances, however, the charging unit does not enter the target hex if doing so would violate the stacking limits (see p. 205, *TW*).

If a unit charges the rear of a Tractor or Trailer that moved this turn, the standard charging rules apply, except half the damage (rounded down) is applied to both units. No roll is made to determine if the Tractor/Trailer is derailed, and the charging unit does not enter the target hex if doing so would violate the stacking limits (as noted above).

If a unit charges the front of a Tractor or Trailer that moved this turn, the standard charging rules apply, except double the standard damage is applied to both units. The standard rules for determining if a the Tractor/Trailer is derailed are used (*Collisions*, p. 149), though the charging unit does not enter the target hex if doing so would violate the stacking limits (as noted above); though if the train derails, there is a chance the charging unit could be rammed. In the next Movement Phase, if the train did not derail and moves first, there is a chance the train will ram that unit (see *Collisions*, p. 149).

In all instances, if a unit fails a charge and cannot displace into the hex at the right or left of the target hex, then the charging unit does not enter any hexes; its movement ends in the last hex prior to the target hex.

**Mobile Structures:** A train is always derailed and displaced if a Mobile Structure enters its hex(s); see p. 167.

## ACCIDENTAL FALLS FROM ABOVE

If a skid leads to a situation where more than a single rail car (Tractors and/or Trailers) enters a hex 2 levels or more lower than its previous hex, use the Unit Displacement and Accidental Falls From Above rules (see pp. 151 and 152 respectively, *TW*). In all situations, resolve all effects (potentially striking another unit in the target hex, damage, displacement and so on) for each Rail Support Vehicle (each Tractor and/or Trailer) before moving on to the next vehicle.

Once the situation has been resolved, treat the hex occupied by the derailed train as an ultra-rough hex (see p. 39), as described under *Derailed Vehicles Due to Movement* (see p. 149).

# LARGE NAVAL VESSEL SUPPORT VEHICLES

The following rules apply to Large Naval Vessel Support Vehicles.

## MOVEMENT

Large Naval Vessels can be very large—longer than a 30-meter hex on a CBT mapsheet. This means a player must first determine the size of template used for the vessel, based on its tonnage (the size of the template will usually be noted on the Record Sheet or in the Technical Readout write-up). If the template is unknown, compare the tonnage of the vessel to the appropriate column of the Airship and Large Naval Vessel Size Table (see p. 241). Once the size of the template is known, players can use the appropriate template from the Large Naval Templates (see record sheets at the back of this book) during game play.

Large Naval Vessels may only change facing by one hexside per hex, and then only once the vessel has moved forward until the center hex of the unit enters the position where the front hex of the unit was after the last facing change. When the unit is moving slowly, this can take more than one game turn to occur. Note that a Template A Large Naval Vessel is only 1 hex in size, so while it can still only change 1 hexside per hex, it does not need to take into consideration the “pivot point” hex when determining how far it must move before it can change its facing again.

The unit pivots around the center point marked as the “Pivot” on the Naval Vessel Template. The cost to change facing is still 1 MP.

Unlike most units, Large Naval Vessels take time to both speed up and slow down. Each turn, a Large Naval Vessel can increase its speed (up to the unit’s Flanking MP limit) or slow down by 1 MP. If a Large Naval Vessel is rendered immobile by damage, it does not come to a sudden halt, but rather decelerates by 1 MP (applied during the Movement Phase whenever the player nominates the unit for movement) every other turn until its speed drops to zero.

**Submarines:** Unlike standard submarines, Large Naval Vessel Submarines are limited in the depths they can change per turn. The maximum number of depths that a Large Naval Vessel Submarine can change up or down is equal to their Template Size as shown on the Large Naval Vessel Sinking Table (see p. 159) +1. For example a Template A could potentially change 6 depths in a turn, while a Template E can only potentially change 2 depths in a turn.

**Running Aground:** Large Naval Vessels may only operate in water hexes and risk running aground when operating in shallower depths. Consult the Large Naval Heights Table (see p. 157) to find the safe water depth in which these units can operate. A unit entering a water hex that is too shallow immediately runs aground and suffers damage. If the unit was moving at 1 to 3 MP, the damage is equal to its tonnage divided by 100 (rounded up); if moving at 4 to 9 MP, multiply that value by 2; if moving at 10 MP or greater, multiply that value by 3. In all cases, the damage is applied as a single grouping against the location that ran aground (in most instances, the front) The unit, now beached, becomes an immobile target for the remainder of the scenario unless another Naval Vessel with the Tractor modification is present and able to extract the beached vessel (see *Naval Tractors*, p. 156).

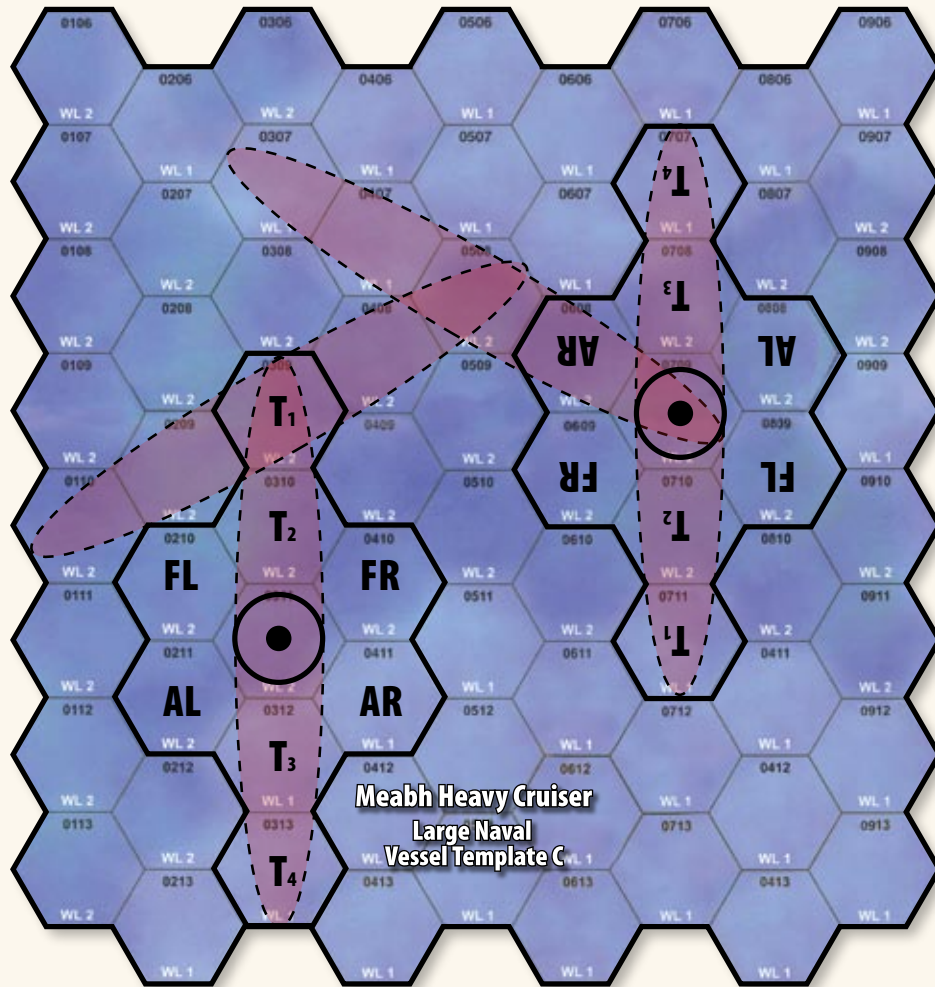

• LARGE NAVAL VESSEL MOVEMENT DIAGRAM •

**Surfacing Large Naval Vessel Support Vehicles:** If a Large Naval Vessel Support Vehicle with the Submersible Chassis and Controls modification rises to a depth occupied by another unit, use the Submerged/Surfaces rules for Mobile Structures to resolve the situation; for example, if such a unit rises underneath a Combat Naval Vessel, the Combat Naval Vessel would be “stranded” in the appropriate hex (see p. 173).

*In the diagram above, a Large Naval Vessel using a Type C Template is traveling at a speed of 4 MP. It moves forward 2 hexes (bringing the center Pivot point to the hex where the bow started) and then spends 1 MP to turn 1 hexside to the right before moving the final MP (bringing total MP expenditure for the turn to 4). Next turn, the unit increases its speed to 5 MP, but as it has not traveled the required distance to bring the Pivot point to where the bow was after the last facing change, it must move forward one more hex before spending 1 MP to turn to the right once more.*

*The next 2 MP move the unit forward enough to once more bring the Pivot point to where the bow started after the last facing change, and thus the unit can make one final facing change at a cost of 1 MP.*

### Collisions

A Large Naval Vessel entering a hex occupied by another unit, automatically rams such units. If a unit is rammed by a Large Naval Vessel Support Vehicle, damage is applied as for a successful Charge Attack (see p. 148, TW), with the following modifications: damage is equal to the current armor of the location which struck the target, plus that location's current internal structure, divided by 10, multiplied by the number of hexes moved in the turn, rounding down. Damage to the Large Naval Vessel is applied normally, per the standard Charge Attack rules; if it strikes an unusual target (see *Unusual Targets*, p. 148, TW) or another Large Naval Vessel, the damage to the Large Naval Vessel is the same as the damage applied to the target.

If the collision occurs on the “deck” or “bottom” of the vessel (due to a unit changing depths up and down), use the location with the highest current internal structure and armor for determining damage to the target (if the target is receiving damage on the “deck” or “bottom” as well, randomly determine a location to apply all damage); the location on the Large Naval Vessel used to determine target damage is also where damage is applied to the vessel from the target.

INTRODUCTION

ADVANCED  
GROUND MOVEMENT

ADVANCED  
COMBAT

ADVANCED  
BUILDINGS

ADVANCED  
SUPPORT  
VEHICLES

GENERAL  
RULES

ADVANCED  
SUPPORT VEHICLE  
CONSTRUCTION

ADVANCED  
WEAPONS  
AND EQUIPMENT

INDEX

RECORD SHEETS



If the weight of the target unit is greater than the weight of the ramming Large Naval Vessel, the target unit is not displaced; the Large Naval Vessel does not enter the hex. If the target unit cannot displace appropriately (due to having run aground, for example), no displacement occurs.

### STACKING

Standard stacking limits do not apply to Large Naval Vessels. No other unit may occupy a hex currently occupied by a Large Naval Vessel unless the other unit is under, above or standing on the Support Vehicle itself.

### CARRYING UNITS

If a Large Naval Vessel Support Vehicle is built with transport bays (see p. 239, *TM*) allowing it to carry other units (such as aerospace fighters, Small Craft, 'Mechs, vehicles and so on), the mounting and dismounting of such units from a stationary Large Naval Vessel follow the same rules as for a grounded DropShip (see *Carrying Units*, p. 89, *TW*).

If a Large Naval Vessel expends MP in the same turn that units are dismounting, only units with Jumping/VTOL MP (including fighters using VTOL movement to take off) may disembark; if a unit mounts a Flight Deck, fighters can take off normally (not using VTOL movement). Additionally, any such unit (except a fighter taking off from a Flight Deck) expending Jumping MP to dismount must make an immediate Piloting/Driving Skill Roll (Anti-'Mech Skill Roll, in the case of infantry) to avoid falling in the target hex.

If an infantry unit fails this roll, apply a single point of damage to all battle armored troopers, or in the case of conventional infantry, apply a single 5-point Damage Value grouping as though another infantry unit had made a successful attack.

A VTOL Vehicle that fails the Driving Skill Roll automatically crashes in the hex from which it was attempting to take off (see *VTOL and WiGE Vehicle Crashes*, p. 68, *TW*); for the purposes of damage, the VTOL Vehicle is considered to have moved 1 hex and randomly determine the damage location. Infantry expending VTOL MP also crash in the hex from which they were attempting to take off, applying damage as described above for infantry using jumping MP.

In all instances, whether a jumping unit failing a PSR and falling in the target hex or a unit expending VTOL MP failing the PSR and crashing in the hex they were attempting to take off from, the units' movement is over.

If the target hex for the dismounting unit is illegal (such as infantry without UMU MP), the unit is automatically destroyed.

Players should also use the rules for dismounting and mounting infantry from naval carriers (see *Dismounting From Naval Carriers*, p. 225, *TW*, and *Naval Carriers*, p. 224, *TW*) as guidelines for how to dismount all units from a Large Naval Support Vessel when it is not adjacent to a land hex, when it is submerged and so on.

### FLIGHT DECKS

Depending on the size of the Flight Deck, friendly fighters, Combat and Support VTOLs and Fixed-Wing Support Vehicles may land on a Large Support Vehicle with a Flight Deck. See *Flight Deck*, p. 312 in the *Advanced Weapons and Equipment* section, for complete details on how to use a Flight Deck.

Enemy units attempting to land on a Flight Deck must apply an additional +2 modifier to the Landing Target Number (this is in addition to the +1 for a unit landing at an unfriendly airfield; see p. 87, *TW*).

### NAVAL TRACTORS

If a Naval Vessel mounts the Tractor Chassis and Controls modification, it may push or pull any one vessel up to five times its own weight. Multiple tractors may add their tractor capacities together, so (for example) two identical naval tractors combined can push or pull any one vessel up to ten times their own weight.

The unit must end the Movement Phase with either its Front or Rear facing oriented toward the rear or front of the unit that has run aground, whichever is more appropriate for moving it directly away from the beaching hex(s). The entire next turn is spent hooking the two vessels together (the Tractor cannot expend any MP, except to stay in the same hex with the same orientation). During the Movement Phase of the following turn, the Naval Tractor may expend MP normally to extract the grounded unit. However, standard rules for the weight of the target unit (considered Trailers) must be taken into account for the MP available to the Naval Tractor (See *Tractors*, p. 205, *TW*).

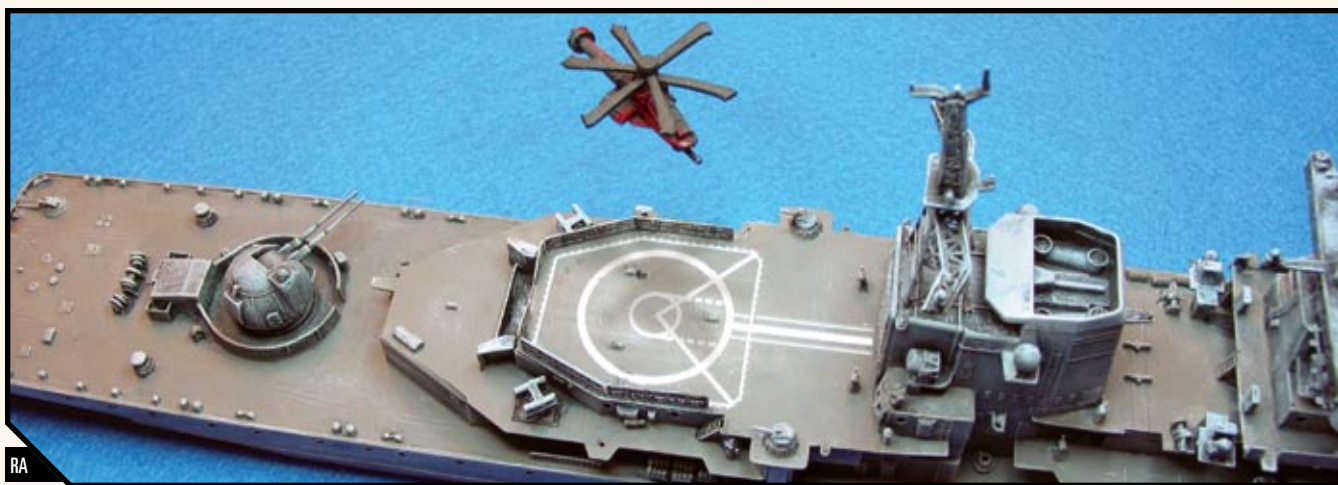

A Warrior VTOL maneuvers for a landing on the helipad of an ancient wet-navy cruiser.



## COMBAT

Large Naval Vessel Support Vehicles follow all the standard rules for Naval Combat Vehicles (see p. 198, *TW*), except as noted below.

### Line of Sight

Large Naval Vessels block line of sight through their hexes like terrain (hill) obstruction of the same height. Additionally, depending on the size of the template used, they rise (and fall) a number of hexes above and below the surface of the water, as shown on the Large Naval Vessel Heights Table.

### LARGE NAVAL VESSEL HEIGHTS TABLE

Template	Heights (Levels) Above/Below Surface*
A	0/1
B	1/1
C	1/2
D	2/2
E	3/3

\*Submersible Large Naval Vessels may not dive in water that exceeds the total sum of the above- and below-surface level values. If they attempt to do so, the vessel will run aground (see p. 154).

### Specialized Attacks

The following specialized attacks apply against Large Naval Vessel Support Vehicles.

**'Mech Mounting (on deck):** A 'Mech with Jumping, UMU or VTOL MP may attempt to board a target vessel. The attacker chooses a specific hex as the target location for landing, using the Large Naval Template (see the record sheets at the back of this book). All the rules for infantry mounting a Large Naval Vessel Support Vehicle as noted above also apply. Additionally, the 'Mech in question must make a standard Piloting Skill Roll to stay standing, with a +1 modifier (apply an additional +4 modifier if the target unit is submerged); a failure means the 'Mech falls in the target hex (though it is still on the target vessel). All appropriate modifiers apply; this includes any weather modifiers if Planetary Conditions are in use (see p. 57), and so on.

In all cases, the 'Mech is located on the "deck" of the target vessel hex; if it fell, it can attempt to stand during the Movement Phase of the following turn. All standard stacking limits apply to the deck of each hex of a Large Naval Vessel Support Vehicle.

Unlike infantry, a 'Mech "mounted" on a submerged unit must make a Piloting Skill Roll during the End Phase of any turn in which the target unit expended MP. A failure means the 'Mech has fallen off; randomly determine an adjacent hex into which the 'Mech would most appropriately fall. It immediately sinks to the bottom of that hex (see *Extreme Depths*, p. 42). Assign damage normally (see *Falling Damage*, p. 57, *TW*). If the 'Mech has UMU MP, however, it does not take falling damage but is simply placed in the adjacent hex at a depth equal to the deck of the unit off of which it fell. If the 'Mech falls off but there is no legal hex for the 'Mech to enter, it is considered destroyed.

**Weapon Attacks by Boarded Units (on deck):** Once a 'Mech or infantry unit has landed on the enemy Large Naval Vessel Support Vehicle (as opposed to infantry used in a boarding action, which "stay on deck"), the attacking unit may not be attacked in turn by the target unit's weapons.

For targeting and damage purposes, the landed unit is assumed to be on the target vessel in the target hex where it landed. During a Movement Phase (Ground), a landed unit may move to an adjacent hex, and may continue to make attacks that turn as well.

Weapon attacks are automatically successful (no to-hit roll required; all Cluster Weapons automatically deal their full Damage Value). However, to-hit rolls should still be made to determine jam rolls, possible critical hits against the target and so on. Physical attacks may also be made, with the following stipulations: only punch, kick and physical weapon attacks may be made, and must still adhere to their standard rules (for example, an arm carrying a physical attack weapon cannot deal damage if a weapon from that arm is fired in the same turn).

### Weapon Attacks

A Large Naval Vessel is far easier to hit than something as small as a 12-meter tall BattleMech. Any attack against a Large Naval Vessel receives an additional to-hit modifier from the Airship and Large Vessel Template Table (see p. 241).

Attacks against a Large Naval Vessel are otherwise conducted as normal, except the attacker chooses the hex; if a Turret hit location is rolled on a hex without a turret, the damage strikes the appropriate side instead.

**Attacks Against a Boarded Unit:** Attacks against a boarded Large Naval Vessel Support Vehicle may strike the 'Mech or infantry units on deck. When a boarded unit takes a hit on any hex whose deck is occupied by any enemy (or friendly) units, roll 1D6. For 'Mechs, on a result of 1–4, the 'Mech does not take damage, and the total value of the weapon damage is applied directly to the Naval Vessel; a result of 5–6 means the boarding 'Mech is hit. For infantry, a result of 1–5 means the infantry does not take damage; on a result of 6, the boarding infantry unit is hit. If infantry and a 'Mech are in the same hex, randomly determine the order in which to make the 1D6 rolls and then roll for each unit until the damage is assigned to either a boarding unit or the Naval Vessel.

For battle armor, a randomly chosen trooper takes maximum damage. Any damage left after the trooper is destroyed is applied to the Naval Vessel. For conventional infantry, mark off damage as though the attack came from another infantry unit (see *Damage From Infantry Units*, p. 216, *TW*).

In all cases, if the unit is destroyed and any damage remains, it is passed on to the target Naval Vessel.

**Attacks Against Boarding Units:** Attacks against any units that have boarded a Large Naval Vessel Support Vehicle (either from other units on the vessel's deck or units not on the Large Naval Vessel) may strike the Large Naval Vessel if they miss. If an attack against such a target is unsuccessful, roll 1D6. On a result of 1–5, nothing happens; on a result of 6, the weapon strikes the Large Naval Vessel in the hex where the target boarding unit is located.

INTRODUCTION

ADVANCED  
GROUND MOVEMENT

ADVANCED  
COMBAT

ADVANCED  
BUILDINGS

ADVANCED  
SUPPORT  
VEHICLES

GENERAL  
RULES

ADVANCED  
SUPPORT VEHICLE  
CONSTRUCTION

ADVANCED  
WEAPONS  
AND EQUIPMENT

INDEX

RECORD SHEETS



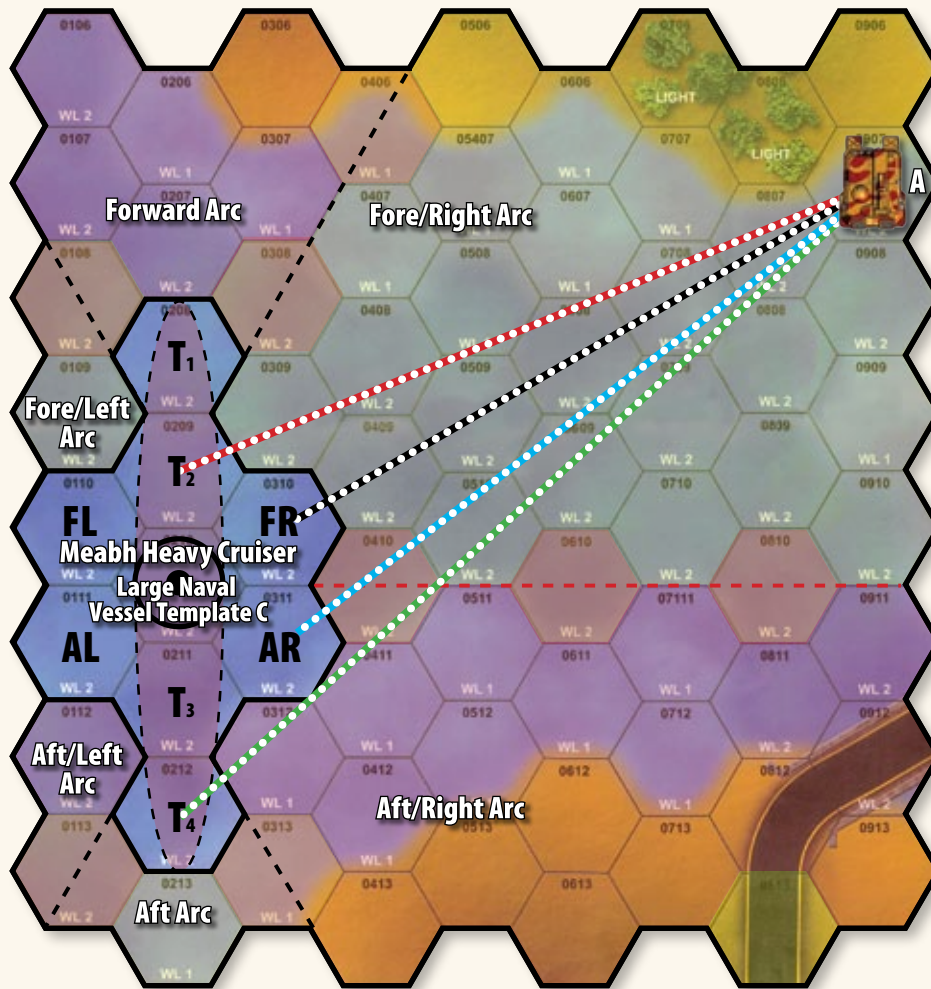

• LARGE NAVAL VESSEL COMBAT DIAGRAM •

On the Archipelago #2 map, a lone Pegasus Scout Hover Tank (Gunnery Skill 4) in Hex A, using flanking speed (8 hexes entered), attacks a Meabh-class Heavy Cruiser Large Naval Support Vehicle that entered 5 hexes this turn on the Large Naval Vessel Combat Diagram above. The players determined before play began that any water hex not adjacent to a clear (land) hex was Depth 6.

The minimum distance to the Meabh is 6 hexes, but in an attempt to knock out some of the unit's turret-mounted weapons, the Pegasus launches an attack against the hex where the first turret position (T2) is located, giving a range to target of 7 hexes. The medium laser in the front cannot be fired, but the Pegasus can fire both SRM-6 launchers mounted in the turret. Fortunately, the Meabh is a big (Template C) target, and so the Pegasus receives a -2 to-hit modifier, for a final modified To-Hit Number of 10 [4 (Gunnery Skill) + 2 (attacker movement modifier) + 4 (long range) + 2 (target movement modifier) - 2 (Template C Large Naval Vessel) = 10]. The Pegasus' controlling player rolls a 7 and 10, meaning 1 missile launcher hit. A result of 8 on the Cluster Hits Table means that 4 missiles struck the target; 8 points of damage are assigned to the turret in the T2 location.

The Meabh (Gunnery Skill 3), which expended cruising MP this turn, returns fire.

The weapons mounted in the Aft-Right location count the range to target from the template hex indicated (AR), which gives a range of 7 hexes to the Pegasus. However, as shown on the Large Naval Vessel Combat Diagram, the Pegasus is outside of the Aft/Right Arc and so neither the 2 AC/5s or 2 medium lasers in that arc can fire on the Pegasus.

The weapons in the Fore-Right location count the range to target from the template hex indicated (FR), which gives a range of 6 hexes to the Pegasus. The 2 AC/5s in the Fore-Right have a modified To-Hit Number of 7 [3 (Gunnery Skill) + 1 (attacker movement modifier) + 0 (short range) + 3 (target movement modifier) = 7]. The 2 medium lasers in the Fore-Right have a modified To-Hit Number of 9 [3 (Gunnery Skill) + 1 (attacker movement modifier) + 2 (medium range) + 3 (target movement modifier) = 9].

The weapons in the T2 turret location count the range to target from the template hex indicated (T2), which gives a range of 7 hexes. The 3 PPCs and 1 large laser in the T2 location all have a modified To-Hit Number of 9 [3 (Gunnery Skill) + 1 (attacker movement modifier) + 2 (medium range) + 3 (target movement modifier) = 9].



The weapons in the T4 turret location count the range to target from the template hex indicated (T4), which gives a range of 9 hexes. The 3 PPCs and 1 large laser in the T4 location all have a modified To-Hit Number of 9 [3 (Gunnery Skill) + 1 (attacker movement modifier) + 2 (medium range) + 3 (target movement modifier) = 9].

Per standard rules, all attacks that strike the Pegasus will use the Left Side of the Hit Location Table.

### Area Effect Weapons

Damage from weapons with an area of effect, such as artillery, is only applied to a single hex of a multi-hex unit. The hex affected receives the highest level of damage, or—if several would receive the same damage—the hex to be damaged is selected by the attacker.

*A Meabh-class Naval Vessel is attacked by two Sniper artillery units firing standard HE rounds. The first strike directly hits one of the hexes occupied by the vessel, inflicting the full 20 points of damage, split into four 5-point Damage Value groupings as normal. The adjacent hexes occupied by the vessel ignore the 10 points of damage that would normally be applied to units in adjacent hexes, but any other units in those hexes are damaged as normal.*

*The second Sniper misses the targeted hex and scatters. However, the new impact hex catches two of the Large Naval Vessel hexes in the outer 10-point blast area. Only one of the two hex strikes (chosen by the attacking player) is counted when determining the damage the vessel receives (two 5-point Damage Value groupings assigned in one of those two hexes only).*

### Turret Destruction

Unlike Small and Medium Naval Vessels, Large Naval Vessel Support Vehicles can survive the destruction of a turret. Additional damage to a destroyed turret transfers to the side armor facing the attacker. Naval Vessels built with the Submersible Chassis and Controls modification (see p. 243) cannot dive once a turret is destroyed. Attempting to do so (or having a turret destroyed while submerged) results in the unit's destruction.

### CRITICAL DAMAGE

The following modifications are made to ground Combat Vehicle critical hit effects (see p. 193, TW), as they apply to Large Naval Vessel Support Vehicles.

**Ammunition:** A Large Naval Vessel Support Vehicle follows the same rules for an ammunition explosion as other vehicles (see p. 194, TW), with the following exceptions.

Only the ammo in the hex where the damage occurred explodes. If there is no ammo in the location hit, the critical hit is ignored.

If the unit mounts CASE, per standard vehicle rules, the ammunition explosion does not damage the internal structure of the location corresponding to the location of the hex hit. Instead damage is applied to the armor of the location corresponding to the damaged hex.

As usual, if a unit is submerged and the armor in a location is destroyed due to an ammunition explosion, that section is flooded and all equipment becomes non-functional (see *Underwater Units*, p. 121, TW).

Each ammunition critical hit reduces the unit's Cruising MP by 1.

**Cargo:** Use the rules for Cargo on DropShips (see p. 239, TW) when determining critical hits against cargo on Large Naval Vessels.

**Crew Killed:** The crew of a Large Naval Support Vehicle is treated like a DropShip crew (see p. 240, TW). For each crew critical hit suffered, one crew box is marked off and a cumulative +1 modifier (for each such hit) is applied to any Gunnery or Piloting Skill Rolls required by the unit. When all six crew boxes have been marked off, the crewmen are dead.

**Engine Hit:** Because of the size and redundancies of an engine on a Large Naval Vessel Support Vehicle, an engine critical hit may often be ignored, while a critical hit to the engine that actually does damage does not immediately disable the Large Naval Vessel.

Whenever an engine critical hit is noted, the controlling player of the targeted vessel immediately rolls 2D6. On a result of 8 or better, the engine hit is ignored. If the result is 7 or less, the engine critical hit is applied. However, such a critical hit does not disable the vehicle. Instead, each engine critical hit reduces the unit's Cruising MP by 1. In both instances, Flanking MP should be recalculated (multiply the Cruising MP by 1.5, rounding up).

### ELECTRONIC EQUIPMENT

Any multi-hex Large Naval Vessel Support Vehicle that carries electronic equipment with an area of effect (such as ECM) treats the source as located in the Pivot point hex on the appropriate Large Naval Vessel Template.

## LARGE NAVAL VESSEL SINKING RATE TABLE

Template Size	Number of Depths per Turn
Size A	5
Size B	4
Size C	3
Size D	2
Size E	1

### UNIT DESTRUCTION

Unlike other units, which are automatically removed from the game when they are destroyed, the size of a Large Naval Vessel—and the fact that other units can be mounted on top of it—means that special rules are used to resolve its destruction (this is done to avoid a magic disappearing ship, leaving 'Mechs several levels above the surface of a water hex, their legs windmilling in the air).

**Note:** These rules do not take into consideration that in a real-world sinking situation, vessels almost always capsize and will tear themselves apart as they gyrate toward the bottom, or the fact that a large vessel will usually have huge sections that remain intact. In an effort to make these rules easy to implement, such realism is ignored. In *BattleTech*, a unit sinks

INTRODUCTION

ADVANCED  
GROUND MOVEMENT

ADVANCED  
COMBAT

ADVANCED  
BUILDINGS

ADVANCED  
SUPPORT  
VEHICLES

GENERAL  
RULES

ADVANCED  
SUPPORT VEHICLE  
CONSTRUCTION

ADVANCED  
WEAPONS  
AND EQUIPMENT

INDEX

RECORD SHEETS



flat; once a hex touches bottom, the unit is immediately removed from the game or reduced to its new terrain (depending on the rules in use).

### Resolving Sinking

A Large Naval Vessel will sink a number of depths per turn equal to its Template Size. This can affect the ability of units on the deck to save themselves before it sinks, and of the crew to abandon ship (see *Ejection And Abandoning Units*, p. 196), as well as how long it takes the “battlefield wreckage” to sink to the bottom (see *Battlefield Wreckage*, p. 187).

A Large Naval Vessel will sink a number of depths equal to its Template Size as shown on the Large Naval Vessel Sinking Rate Table; note that this depth is measured from the bottom of the unit. For example, a Template E unit is 6 levels high, 3 of which sit below the water line, 3 above the water line. As it sinks 1 depth per turn, it will require 4 turns before it completely submerges.

All such sinking movement is made automatically (and simultaneously in the case of multiple sinking ships) at the end of the Movement Phase (Ground), after all other movement has been made.

As soon as any hex of a sinking Large Naval Support Vessel strikes the bottom of a water hex, that hex of the ship is immediately removed from play, or converted into its appropriate terrain type if using Battlefield Wreckage rules (see p. 187). This could result in various hexes of the ship “breaking off” and being removed from play or reduced to a terrain type across many turns as a large ship sinks through terrain of different levels/depths.

While the unit is sinking, it still occupies the same number of depths as its Template Size (minus any hexes that might have broken off by already hitting the bottom of their respective hexes). If the sinking unit enters the hex(s) of another unit (or another unit enters a hex of the sinking unit that has yet to hit bottom), use the Submerged/Surfaces rules for Mobile Structures to resolve the situation (see p. 173).

Note that once a Large Naval Vessel has become submerged, if there is no underwater combat occurring and no other units on board (either on deck, or in the cargo bay) that need to be dealt with, if all player agree, the vessel can simply be removed from the playing area (if Battlefield Wreckage is being used, the players can simply assign the appropriate new terrain to the relevant hexes). In other words, due to the length of time and complexity involved of the sinking of a Large Naval Vessel, the players should only go through all the steps of a sinking vessel if they wish.

**Running Aground:** If a unit has run aground when it is destroyed, any hex(s) that already touch the bottom of a hex are instantly removed from play or reduced to their appropriate terrain type, as discussed above.

**Water Flow:** If using the Water Flow rules (see p. 52), the flow of water will move a sinking ship; players should first sink the ship and then apply any movement based on water flow. If this results in a hex of the sinking unit striking the underlying terrain of a new hex (that is, the bottom of the ship entering the hex at the level of the underlying terrain in that hex), the ship is first moved and then the hex(s) that struck bottom are immediately removed from play or reduced to the same terrain type, as describe above. If water flow will move a sinking unit into a hex it cannot enter (such as the side of a submerged hill), then the unit remains in the hexes before the water flow movement was applied; no displacement occurs.

### Units Mounted on a Sinking Vessel (On Deck)

For units mounted on the deck of a sinking Large Naval Vessel, use the following rules.

**'Mechs:** A standing 'Mech must make a Piloting Skill Roll at the end of any turn after a ship has been moved for sinking purposes. The results of a failed roll depend on whether or not the deck of the Large Naval Vessel hex that the 'Mech is standing on is submerged.

If the hex is not submerged, the 'Mech falls in the hex and takes standard falling damage, but remains in the hex.

If the hex is submerged, a failure means the 'Mech has fallen off; randomly determine an adjacent hex into which the 'Mech would most appropriately fall. It immediately sinks to the bottom of that hex (see *Extreme Depths*, p. 42). Assign damage normally (see *Falling Damage*, p. 57, *TW*). If the 'Mech has UMU MP, it does not take falling damage, but is simply placed in the adjacent hex at a depth equal to the deck of the unit from which it fell. In the case of 'Mechs with UMU MP, this only applies if the controlling player continues to keep the 'Mech on the sinking vessel. As soon as the deck of the hex the unit occupies has reached Depth 2, the controlling player can disembark the vessel automatically, using UMU MP with no further rolls required.

If the 'Mech falls off but there is no legal hex for it to enter, it is considered destroyed.

**Infantry With UMU MP:** As soon as the deck of the hex occupied by an infantry unit with UMU MP has reached Depth 1, the controlling player can disembark the vessel automatically, using UMU MP with no further rolls required.

**All Units:** Only units with Jumping/VTOL MP (including fighters using VTOL movement to take off) may disembark a sinking ship; if a unit mounts a Flight Deck, fighters can take off normally (not using VTOL movement). Additionally, any such unit (excluding a fighter taking off from a Flight Deck) expending Jumping MP must make an immediate Piloting/Driving Skill Roll (Anti-'Mech Skill Roll, in the case of infantry) to avoid falling in the target hex.

If an infantry unit fails this roll, apply a single point of damage to all battle armored troopers, or in the case of conventional infantry, apply a single 5-point Damage Value grouping as though another infantry unit had made a successful attack.

A VTOL Vehicle that fails the Driving Skill Roll automatically crashes in the hex from which it was attempting to take off (see *VTOL and WiGE Vehicle Crashes*, p. 68, *TW*); for the purposes of damage, the VTOL Vehicle is considered to have moved 1 hex and randomly determine the damage location. Infantry expending VTOL MP also crash in the hex from which they were attempting to take off, applying damage as described above for infantry using jumping MP.

In all instances, whether a jumping unit failing a PSR and falling in the target hex or a unit expending VTOL MP failing the PSR and crashing in the hex they were attempting to take off from, the unit's movement is over.

If the target hex for the dismounting unit is illegal (such as infantry without UMU MP entering a water hex), the unit is automatically destroyed.

Players should also use the rules for dismounting and mounting infantry from naval carriers (see *Dismounting From Naval Carriers*, p. 225, *TW*, and *Naval Carriers*, p. 224, *TW*) as guidelines for how to dismount all units from a sinking Large Naval Vessel Support Vehicle when it is not adjacent to a land hex, when it is submerged and so on.



### Units Mounted On A Sinking Vessel (In Cargo Bay)

If any units are mounted in the cargo bay of a sinking Large Naval Vessel, use the following rules.

All the standard rules for a friendly unit dismounting a DropShip apply (see p. 89, *TW*), with the following additions:

Any friendly active unit may dismount into a legal non-water hex, if such an adjacent hex exists.

If there are no non-water hexes adjacent, active friendly units (see *Transport Bays (Expanded)*, p. 217) can attempt to dismount the Large Naval Vessel using the rules for dismounting and mounting infantry from naval carriers (see *Dismounting From Naval Carriers*, p. 225, *TW*, and *Naval Carriers*, p. 224, *TW*) as guidelines for how to dismount all units from a sinking Large Naval Vessel Support Vehicle.

In situations where there are no non-water hexes adjacent, before the Large Naval Vessel is submerged, 'Mechs and ProtoMechs, or infantry with UMU MP, as well as hover vehicles, may dismount into an adjacent water hex. After the Large Naval Vessel is submerged, only 'Mechs or ProtoMechs or infantry with UMU MP may dismount. If a unit with UMU MP dismounts in this fashion, it is placed in the most appropriate adjacent hex, at a depth equal to the "deck" of the Large Naval Vessel. Units without UMU MP that dismount in this fashion automatically fall as though they were on the deck of the Large Naval Vessel and failed a Piloting Skill Roll (see *Units Mounted on a Sinking Vessel (On Deck)*, p. 160).

In all instances, if all bay doors have been damaged (by units mounting through the doors or due to critical damage), no units mounted in the cargo bay can dismount.

**Non-Active Units:** Any non-active units (see *Transport Bays (Expanded)*, p. 217) must be activated prior to dismounting using the rules above.

**Enemy Units:** Any enemy unit that has mounted through a bay door (see *Mounting Through a Bay Door (Into a Cargo Bay)*, p. 188) may follow the exact rules as noted above for dismounting, except apply a -3 modifier to the Piloting Skill Roll.

### When a Hex of a Sinking Unit Is Destroyed

When a hex of a Large Naval Vessel Support Vehicle strikes the bottom and is removed from play or reduced to its battlefield wreckage terrain type (see the rules directly under *Unit Destruction*, p. 159), and that hex has units mounted on it, those units automatically fall into the hex they occupy. Use the following rules to resolve these situations.

**'Mechs:** If the deck of the Large Naval Vessel hex the unit occupies is above water, the 'Mech takes falling damage to the surface of the water, then falling damage to the bottom, which are both resolved immediately (see *Falling Damage*, p. 57, *TW*). If the Large Naval Vessel hex the unit occupies is underwater, the 'Mech takes standard underwater falling damage (see *Falling Damage*, p. 57, *TW*). In both instances, the unit immediately sinks to the bottom of the water hex to take that falling damage.

If the 'Mech has UMU MP and it falls from above the water's surface, it takes standard falling damage as above and then remains at Depth 1 in the hex. If the 'Mech has UMU MP and it falls while underwater, it is instead placed at its current depth with no additional effects.

If the hex is not a water hex (the Large Naval Vessel Support Vehicle has run aground; see *Running Aground*, p. 154), then

the 'Mech takes standard falling damage (see *Falling Damage to a 'Mech*, p. 69, *TW*).

**Infantry:** If an infantry unit does not have UMU MP and it falls into a water hex, it is automatically destroyed.

If an infantry unit has UMU MP and the deck of the Large Naval Vessel hex the unit occupies is above water, the unit takes infantry falling damage (see *Infantry Falling Damage Table*, p. 151, *TW*), divided by 2 (round down). After the damage is assigned, the infantry unit is placed at Depth 1 in the hex.

If the infantry unit has UMU MP and it falls while underwater, it is instead placed at its current depth with no additional effects.

If the hex is not a water hex (the Large Naval Vessel Support Vehicle has run aground; see *Running Aground*, p. 154), then the infantry unit takes standard falling damage (see *Infantry Falling Damage Table*, p. 151, *TW*).

**Naval Units:** If a Naval Vessel (for whatever reason) is on a Large Naval Vessel and the deck of that hex(s) is above water, the unit takes standard falling damage when it hits the water's surface (see *Falling Damage*, p. 57, *TW*); if the unit is not destroyed, it is then placed on the surface of the water in that hex. If the hex is not a water hex (the Large Naval Vessel Support Vehicle has run aground; see *Running Aground*, p. 154), the unit is automatically destroyed.

**All Units:** All other units that fall into a water hex are automatically destroyed. If the hex is not a water hex (the Large Naval Vessel Support Vehicle has run aground; see *Running Aground*, p. 154), then the units take standard falling damage (see *Unit Displacement and Accidental Falls From Above*, p. 151, *TW*).

In all cases, if multiple units occupy a hex, randomly determine the order in which the falls are resolved. Resolve stacking limits if necessary, using the standard stacking rules.

### Destruction of a Sinking Vessel and Mounted Units (in Cargo Bays)

Use the DropShip destruction rules (see p. 90, *TW*) to determine if any units survive the destruction of a Large Naval Vessel. Resolve completely the sinking and final destruction of all hexes of a Large Naval Vessel before determining if any units mounted inside the vessel survived.



RA

An ancient Sovereign Class cruiser on patrol.

INTRODUCTION

ADVANCED  
GROUND MOVEMENT

ADVANCED  
COMBAT

ADVANCED  
BUILDINGS

ADVANCED  
SUPPORT  
VEHICLES

GENERAL  
RULES

ADVANCED  
SUPPORT VEHICLE  
CONSTRUCTION

ADVANCED  
WEAPONS  
AND EQUIPMENT

INDEX

RECORD SHEETS





• SINKING SHIP DIAGRAM •

In the Sinking Ship Diagram at left, a group of players are playing a large wet-naval battle, including Large Naval Vessels, submarines, 'Mechs, battle armor, fighters and more. To create a cooler and more tactical-oriented environment for the surface battle as well as the underwater battle, the players are using standard mapsheets completely submerged in water. It is Turn 6 of the game and the players are using the Battlefield Wreckage rules (see p. 187).

A Luftenburg Supercarrier is on the Box Canyon (now ocean) mapsheet. The surface of the water is 12 Depths above the Level 0 Clear terrain depicted by the mapsheet. As the Luftenburg is a Template E Large Naval Vessel Support Vehicle, it has 6 levels of height, 3 levels above the water and 3 levels below. This puts the bottom of the Luftenburg at Depth 9... only a single depth separating it from the bottom of Hexes A, D, E, F, G, I, M, O, Q, R, V, W and Y.

All three of the Luftenburg's Flight Decks are occupied by fighters; the fighters are located in Hexes F, M and S (the fighters in Hexes F and S landed on Turn 1, while the fighter in Hex M only landed 2 turns ago). In addition, thanks to some combat drops, there's a battle raging on the deck: a Mad Cat in Hex A, an Undine battle armor in Hex C, a Spider in Hex D, a Sylph battle armor in Hex V and another Mad Cat in Hex X.

During the Weapon Attack Phase of Turn 6, the internal structure of a location is destroyed, destroying the Luftenburg. It will begin to sink during the following turn, 1 Depth each turn per the Large Naval Vessel Sinking Rate Table.

During the Movement Phase of Turn 7, the 'Mechs in Hexes A and X do not have Jumping or VTOL MP and so can do nothing to save themselves. The controlling player leaves them in place. The Undines won't have any issue, so the controlling player also leaves them in place.

For the Sylph battle armor, the controlling player expends 3 VTOL MP to turn its Level 3 into Elevation 6 and then leaves it in the hex to watch the fun.

The Spider has jump jets, but unfortunately there is no non-water hex within range of its 8 Jumping MP. However, its pilot knows the unit is about to be in a world of hurt as the ship breaks up and various hexes of the Large Naval Vessel are destroyed, so the controlling player decides to jump to Hex Z. Though he'll need to make a Piloting Skill Roll at a +1 modifier to successfully stand in Hex Z at Depth 12, that is by far preferable to falling such a distance. Because it's not lower than Depth 15, he won't have to deal with crush depth check, so he'll just have to walk the Spider out... it'll take a while, but the 'Mech should come out with relatively little damage.

The fighters in Hexes F and S have been on deck long enough since they landed, and so the controlling player immediately makes a Control Roll for both fighters; they both successfully take off. Unfortunately, the fighter in Hex M has not been landed long enough and so cannot move.

Finally, the controlling player of the Luftenburg starts to launch lifeboats. Looking up Ejection and Abandoning Units rules under General Rules (see p. 196), the players finds the Naval Vessel rules. The Piloting Skill of the Crew is 5, so the controlling player makes a Piloting Skill Roll and gets a result of 10—a MoS of 5. That means 6 lifeboats successfully launched and are placed in adjacent hexes (at the discretion of the controlling player).

At the end of the Movement Phase of Turn 7, the Luftenburg sinks 1 Depth. Hex A, D, E, F, G, I, M, O, Q, R, V, W, and Y are immediately reduced to ultra-rubble; each of those hexes is now a Depth 4 ultra-rough hex.



The fighter in Hex M falls into the water and is immediately destroyed.

The 'Mech in Hex A falls 2 levels to the water's surface (it was at Level 3 on the deck of the ship, but the ship sank 1 Depth before it was reduced) and takes 12 points of falling damage  $[75 \text{ (tonnage of Mad Cat)} \div 10 = 7.5 \text{ (rounding up to 8)} \times (2 \text{ (levels fallen)} + 1) = 24 \div 2 = 12]$ ; note that since the unit is not yet underwater, no rolls for a hull breach are made when applying this damage (see Underwater Units, p. 121, TW). The Mad Cat will then sink 4 more Depths and take 20 points of falling damage  $[75 \text{ (tonnage of Mad Cat)} \div 10 = 7.5 \text{ (rounding up to 8)} \times (4 \text{ (depths fallen)} + 1) = 40 \div 2 = 20]$ ; unlike when striking the surface of the water, a hull breach avoidance roll must be made for each Damage Value grouping applied to the now-submerged 'Mech. Under standard rules, the Mad Cat would be stuck, as all hexes lower than the Depth 4 "shelf" it is on represent more than a Depth 3 change. However, as the players are using the Leaping advanced rule (see p. 22), the controlling player in a future turn will make the move and hope that the Mad Cat can walk out of the water.

The infantry in Hex C don't need to do anything yet, but the 'Mech in Hex X must make a Piloting Skill Roll to avoid falling off; the player succeeds and the 'Mech continues on the boat.

Finally, the controlling player once again launches lifeboats. A Piloting Skill Roll result of 8 only gives a MoS of 3. That means only 4 lifeboats successfully launched this turn.

At the end of the Movement Phase of Turn 8, the Luftenburg sinks 1 Depth. Hex N of the ship is immediately reduced to an ultra-rough hex. Once again, the Mad Cat in Hex X must make a Piloting Skill Roll, which succeeds.

The result of this turn's Piloting Skill Roll to launch lifeboats is a 5; no MoS, so only 1 lifeboat successfully launches.

At the end of the Movement Phase of Turn 9, the Luftenburg sinks 1 Depth and the Mad Cat must once again make a Piloting Skill Roll; once again, the controlling player rolls successfully.

The controlling player of the Luftenburg makes one last desperate attempt to launch lifeboats during the Movement Phase of Turn 10. At the end of the Movement Phase, the deck will be submerged and it will be impossible to launch lifeboats. A final Piloting Skill Roll results in a 12! That gives a MoS of 7, so 8 lifeboats successfully launch. Unfortunately, only 19 lifeboats have been launched so far, which equals 190 crew. As the Luftenburg has a crew of 987 (minus any pilots that dismounted with their units—the vehicles that were dismounted, or the fighters that launched), the controlling player is left with two options: make a Piloting Skill Roll at +2 for each lifeboat launched this last turn, with 1 point of damage inflicted against each boat for each 1 of the MoF, or he can simply have all crewmen abandon ship and float in life vests in the water. While his Luftenburg is a goner, he's still got plenty of other naval and airborne units in the area and so is confident of his search and rescue operations. He chooses the latter option (rather than risk killing much of the crew through questionable lifeboat-launching operations).

At the end of the Movement Phase of Turn 10, the Luftenburg sinks 1 Depth. The bottom of the Luftenburg hexes that have not yet been reduced to battlefield wreckage are at Depth 7. As the Luftenburg has a height of 6 hexes,

that means any units still on the deck are encountering the water for the first time. The Undine in Hex C, since it has UMU MP, is immediately placed at Depth 1 in Hex C. The Mad Cat in Hex X is now at partial cover and once again must make a Piloting Skill Roll to avoid falling. This time the controlling player finally fails. In this situation, a failure doesn't mean the 'Mech falls in Hex X, however, as the Luftenburg's Hex X is now underwater. The most appropriate hex adjacent to the Luftenburg is chosen. In this case, Hexes XA and XB are equally appropriate, so the controlling player randomly determines the location where the 'Mech ends up: Hex XA. The 'Mech takes 48 points of falling damage  $[75 \text{ (tonnage of Mad Cat)} \div 10 = 7.5 \text{ (rounding up to 8)} \times (11 \text{ (depths fallen)} + 1) = 96 \div 2 = 48]$ ; note that it fell 11 depths, since the surface of Hex X was at Depth 1 when the Mad Cat fell off. As with the other Mad Cat, hull breach avoidance rolls must be made for every Damage Value grouping applied to the 'Mech (see Underwater Units, p. 121, TW).

At the end of the Movement Phase of Turn 11, the Luftenburg sinks 1 Depth.

At the end of the Movement Phase of Turn 12, the Luftenburg sinks 1 Depth.

During the Movement Phase of Turn 13, a Verne Cargo Sub attempts to pass underneath the sinking ship, but doesn't quite make it and is at Depth 10 in Hex P. At the end of the Movement Phase of Turn 13, the Luftenburg sinks 1 Depth. As the Verne Cargo Sub occupies the same depth in a hex now occupied by the Luftenburg, a standard charging attack occurs, inflicting 46 points of damage on the Verne  $[80 \text{ (current front location internal structure)} + 850 \text{ (current front location armor)} = 930 \div 10 = 93 \times 1 \text{ (hexes moved)} = 93 \div 2 \text{ (occurred in a water hex)} = 46.5, \text{ rounding down to } 46]$ . Randomly determining the location, the damage is applied to the front armor, leaving it with 54 points of damage. As the Damage Value of the ram exceeded the Verne's BAR, the controlling player of the Verne must roll once on the Ground Vehicle Critical Hits Table. If it mattered, the Verne would have inflicted 46 points of damage on the Luftenburg's front armor. Finally, the Verne is displaced to Depth 11. Additionally, Hex B is immediately reduced to ultra-rough at Depth 10.

During the Movement Phase of Turn 14, the controlling player of the Verne (who was lucky enough not to roll a critical hit that would've reduced its movement) quickly moves the Verne out of the way of the sinking ship. At the end of the Movement Phase of Turn 15, the Luftenburg sinks 1 Depth. Hexes B, H, J, Q, R, S, T and Y are immediately reduced to ultra-rough at Depth 12.

At the end of the Movement Phase of Turn 16, the Luftenburg sinks 1 Depth and its Hex L is immediately reduced to ultra-rough at Depth 13.

Finally, at the end of the Movement Phase of Turn 17, the Luftenburg sinks 1 Depth and the final Hex K is immediately reduced to ultra-rough at Depth 14.

Now that the final destruction of all hexes has been determined, the controlling player of the Luftenburg uses the DropShip destruction rules (see p. 90, TW) to determine if any of the units mounted on the Large Naval Vessel survived; if any of the units cannot enter a water hex, they are automatically destroyed.

INTRODUCTION

ADVANCED  
GROUND MOVEMENT

ADVANCED  
COMBAT

ADVANCED  
BUILDINGS

ADVANCED  
SUPPORT  
VEHICLES

GENERAL  
RULES

ADVANCED  
SUPPORT VEHICLE  
CONSTRUCTION

ADVANCED  
WEAPONS  
AND EQUIPMENT

INDEX

RECORD SHEETS



# LARGE AIRSHIP SUPPORT VEHICLES

Large Airship Support Vehicles follow all the same rules for movement and combat while airborne as Small- and Medium-sized Airships (see p. 204, *TW*).

## MOVEMENT

The following additional rules apply to Large Airship movement.

### Landing and Liftoff

As described in detail on page 204 of *Total Warfare*, Airships use the Spheroid Small Craft rules for landing and take-off. However, some additional rules apply for Large Airships.

A Large Airship attempting to land has a “footprint” equal to the size of the appropriate template from the Large Naval Templates, as described above. Every hex within that footprint, along with the terrain in the footprint, must be one level higher or less than the height of the grounded Airship along the landing strip, as determined by the Pivot point hex. In other words, while the Pivot point (the gondola) is touching the ground, the entire rest of the footprint (the gas-filled structure above it) is considered one level higher. If any hex within the footprint contains terrain or levels that are two levels higher or more than the Pivot point hex, consult the Landing Modifiers Table (see p. 86, *TW*), and apply all modifiers and/or crash results as normal.

**Water:** Airships with the Amphibious Chassis and Controls modification may land in water hexes, though the same general restrictions above apply.

## STACKING

Standard stacking limits do not apply for Large Airships. No other unit may occupy the Pivot point hex of a grounded Large Airship. Any unit of Level 1 height or less can enter any other hex of the grounded Large Airship's footprint, per standard movement. However, the height of the underlying terrain plus the height of the unit cannot be higher than the level of the footprint in that hex. Infantry can always pass through any hex occupied by a grounded Large Airship footprint, but they cannot enter the Pivot point hex.

For example, a Large Airship with a Pivot point on a Level 0 hex could have Level 1 hexes anywhere within its footprint. However, any unit with a Level 1 height (a ProtoMech, vehicle and so on) could not enter such a hex, as the unit's total height would then be 2 [1 (level of the hex) + 1 (height of the unit) = 2], which is higher than the level of the Airship's footprint in that hex.

## CARRYING UNITS

If a Large Airship is built with cubicles allowing it to carry other units (such as aerospace fighters, Small Craft, 'Mechs, vehicles and so on), the mounting and dismounting of such units from a grounded Airship follow the same rules as for a grounded DropShip (see *Carrying Units*, p. 89, *TW*). The units are placed in adjacent hexes to the Pivot point hex. The exception occurs if a

mounting or dismounting unit has a height greater than its level plus the level of the underlying terrain in the adjacent hex to the Pivot point (for example, a Level 2 'Mech). In such a case, apply the following rules: a dismounting or mounting unit is placed in the most appropriate hex adjacent to the template of the Airship, nearest the Pivot point hex.

For an airborne Large Airship, a variety of different rules cover various unit types: for launching/recovering fighters, use the *Launching/Recovering Fighters/Small Craft* rules (see p. 84, *TW*); for mounting infantry with Jumping /VTOL MP, use the *Aerospace Carriers* rules (see p. 224, *TW*); for dismounting infantry with Jumping /VTOL MP, use the *Dismounting From Aerospace Carriers* rules (see p. 225, *TW*).

## FLIGHT DECKS

Depending on the size of the Flight Deck, friendly fighters, Combat and Support VTOLs and Fixed-Wing Support Vehicles may land on an Airship Support Vehicle with a Flight Deck. See *Flight Deck*, p. 312 in the *Advanced Weapons and Equipment* section, for complete details on how to use a Flight Deck.

Enemy units attempting to land on a Flight Deck must apply an additional +2 modifier to the Landing Target Number (this is in addition to the +1 for a unit landing at unfriendly airfield; see p. 87, *TW*).

## COMBAT

Large Airship Support Vehicles follow all the standard rules for Airship Support Vehicles in combat (see p. 206, *TW*), except as noted below.

### Line of Sight

Large Airships block line of sight when grounded. However, players must take into account that any non-Pivot point footprint hex is one level higher than the underlying terrain of the Pivot point hex. In addition, the total height of the footprint that blocks LOS is dependent on the template used for the grounded Airship, as shown on the Large Naval Vessel Heights Table (see p. 157).

Finally, a grounded Large Airship may be easier to hit. Any attack against a grounded Large Airship receives an additional to-hit modifier from the Airship and Large Vessel Template Table (see p. 241).

## ELECTRONIC EQUIPMENT

Any multi-hex Airship Support Vehicle that carries electronic equipment with an area of effect (such as ECM) treats the source as located in the Pivot point hex on the appropriate Large Naval Vessel Template.

## ACCIDENTAL FALLS FROM ABOVE

If a unit accidentally falls onto a footprint hex, assign damage normally (see p. 152, *TW*). However, no unit can maintain purchase on the rigid, air-filled structure that the footprint template represents, and is automatically displaced to the closest, most appropriate and legal hex; if more than one hex fits that description, randomly determine the hex into which the unit is displaced.

# MOBILE STRUCTURES



INTRODUCTION

ADVANCED  
GROUND MOVEMENT

ADVANCED  
COMBAT

ADVANCED  
BUILDINGS

ADVANCED  
SUPPORT  
VEHICLES

GENERAL  
RULES

ADVANCED  
SUPPORT VEHICLE  
CONSTRUCTION

ADVANCED  
WEAPONS  
AND EQUIPMENT

INDEX

RECORD SHEETS



The following rules apply to Mobile Structures.

**Player Adjudication:** As noted in the *Introduction* (see p. 9), despite best efforts to the contrary, player adjudication will likely be required as players incorporate more and more of the various advanced rules from *Tactical Operations* into their games. Mobile Structures, by their very nature, significantly raise the likelihood of player adjudication. While we've tried to be as comprehensive as possible, players should be aware before starting a game that they may need to make rulings as a Mobile Structure moves and fires across complex terrain.

## Mobile Structure Template

As described in the Mobile Structure construction rules, these units can be a variety of shapes and sizes. While the Structure Record Sheets allow for the tracking of equipment, damage and so on for a Mobile Structure, the record sheet can't really be used to show a Mobile Structure on the map. The Mobile Structure Template (see the record sheets at the back of this book) is a sheet of blank hexes—the same size as the hexes found on *BattleTech* mapsheets—that players can photocopy and then cut out to make the desired “footprint” shape of their Mobile Structure, plainly marking the “centermost” hex. Then, particularly when dealing with Ground Mobile Structures, the player can put the template directly on the mapsheet to designate its location, or can simply use it as a guide for determining where the Mobile Structure can and cannot move.

## MOVEMENT

Mobile Structures do not have Cruising/Flanking Movement Points, but instead have a Maximum MP value. The Movement Point cost for Mobile Structures to enter a given hex is noted on the Mobile Structure Movement Costs Table (see p. 166). A Mobile Structure does not pay these movement costs for every hex in the new hex row it enters. Instead, the player determines the move he wishes to accomplish with his Mobile Structure, and then finds the single hex in the new hex row with the most expensive MP requirement. If the Mobile Structure meets that MP requirement, then the Mobile Structure may enter the new row of hexes (see *Sublevels*, at right, for the exception).

In all instances, whenever a Mobile Structure expends any MP, it is considered to have chosen a Flanking Movement Mode.

**MP Reduction:** Regardless of damage taken by the Mobile Structure (through movement or combat), its Maximum MP and quarter-MP expenditure capability is never reduced (the motive system is distributed throughout every hex of the unit).

**Air Mobile Structures:** Beyond the difference of MP tracking and expenditure noted for Mobile Structures, Air Mobile Structures follow all the same rules for movement restrictions as Large Airships (see p. 164). They also follow Large Airship rules for landing and take-off, except that the “footprint” of the Air Mobile Structure (as determined by the size of unit in question) is all the same height across the bottom (as opposed to one level above the height of the Pivot point hex on an Airship).

**Water Mobile Structures:** Water Mobile Structures may only operate in water hexes and can run aground when operating in shallower depths. Consult the Mobile Structure Types Table (see p. 260) to find the safe water depth in which these units can operate. A unit entering a water hex that is too shallow immediately runs aground and suffers 50 points of damage to all hexes involved. The unit, now beached, becomes an immobile target for the remainder of the scenario, unless another Naval Vessel/Water Mobile Structure with the Tractor modification, and with a number of hexes equal to or larger than the beached Mobile Structure, is present and able to extract the unit (see *Naval Tractors*, p. 156).

Additionally, like Large Naval Vessels, Water Mobile Structures take time to speed up and slow down. Each turn, a Mobile Structure can increase its speed (up to the unit's Maximum MP limit) or slow down by 1 MP. If a Water Mobile Structure is rendered immobile by damage, it does not come to a sudden halt, but rather decelerates by 1 MP (applied during the Movement Phase whenever the player nominates the unit for movement) every other turn until its speed drops to zero.

Finally, regardless of the size of a Water (Submersible) Mobile Structure, it may only change 1 depth, up or down, in a turn.

**Planetary Conditions:** Mobile Structures deal with any additional Planetary Conditions (see p. 28) not already covered on the Mobile Structure Movement Costs Table above, in the following manner: all terrain modifications are ignored; all weather conditions except lighting (dawn, dusk and so on) are downgraded two levels to affect a Mobile Structure (for example, Heavy Rainfall would affect a Mobile Structure as though it were Light Rainfall, while Light Hail would not affect a Mobile Structure at all). The full effects of Terrain Conditions are applied as appropriate to Mobile Structures.

## Level Change (Ground)

A Ground Mobile Structure cannot change levels if half or less of the hexes on the side of the unit entering the new hex row are not at the same change in level. For example, a Mobile Structure currently occupies all Level 0 hexes. The 5-hex long side that is attempting to enter a new row of hexes encounters some hexes that are Level 1. In order for the Mobile Structure to be able to move forward, at least 3 of the 5 hexes must be Level 1 hexes.

**Sublevels:** A Mobile Structure can move across hexes that are considered a sublevel to its own base height (such as a canyon or crevasse), provided the distance spanned is always 1/3 or less the width in hexes of the unit itself. For example a 3- or 4-hex wide Mobile Structure would only be able to straddle a 1-hex wide sublevel “canyon,” while a 6-hex wide Mobile Structure could straddle a 2-hex wide sublevel “canyon.”

**LOS Height:** A large Ground Mobile Structure will take several turns to move across large hills of multiple levels. As such, the “roof” of a Ground Mobile Structure may have different LOS Heights in different hexes of the unit, depending upon the level of the underlying terrain of a given hex. Make sure to take this into consideration during the Weapon Attack Phase.

## Terrain Reduction (Air, Ground)

Whenever a Mobile Structure enters a hex, including a clear hex, it automatically reduces (changes) that hex to a rough hex (see *Buildings*, p. 168, for the exception).

## MOBILE STRUCTURE MOVEMENT COSTS TABLE

Movement Action /Terrain Type	MP Cost Per Hex/Terrain Cost	Prohibited Terrain
<b>Cost to Enter Any Hex</b>	1	
<b>Terrain Cost When Entering Any New Hex</b>		
Clear	+0	Water
Paved/Bridge	+0	Water
Road/Rough/Gravel Piles/Sand/		
Tundra/Planted Fields	+0	Water
Ultra Rough	+1	Air, Water
Light/Heavy Woods/Jungles	+0	Air, Water
Ultra-Heavy Woods/Jungles	+1	Air, Water
<b>Water</b>		
Depth 0	+0	Air
Depth 1/Depth 2	+1 (Level change MP cost not included)	Air
Depth 3-15	+2† (Level change MP cost not included)	Air, Ground*
Depth 16+	—‡	Air, Ground
<b>Level change (up or down)</b>		
Level 1/Sheer Cliffs	+0	Water
Level 2	+1	Water
Level 3+	—	Ground, Water, Air
<b>Rubble</b>		
Rubble	+0	Water
Ultra Rubble	+2	Air, Water
<b>Buildings**</b>		
<b>Standard</b>		
Light/Medium/Heavy	+0	Water
<b>Hangar</b>		
Light/Medium/Heavy/Hardened	+0	Water
Fence	+0	Water
<b>Wall</b>		
Light/Medium/Heavy	+0	Water
Hardened	+1	Water
<b>Gun Emplacement</b>		
Light/Medium/Heavy	+0	Water
Hardened	+1	Water
<b>Fortress</b>		
Medium	+1	Water
Heavy	+2	Water
Hardened	—	Air, Ground, Water
<b>Castles Brian</b>		
Heavy	—	Air, Ground, Water
Hardened	—	Air, Ground, Water
Heavy Industrial Zone	+1	Water

\*To enter a water hex of Depth 3 or greater, a Ground Mobile Structure must mount the Environmental Sealing Chassis and Controls modification.

\*\*A Mobile Structure that enters a building hex never moves inside the building (see *Buildings*, p. 168).

†Only applies to Ground Mobile Structure; Water Ground Mobile Structures pay the standard 1 for entering a water hex.

‡Water Ground Mobile Structure may enter such depths, paying the standard 1 for entering a water hex.



**Terrain Factor:** If using the Terrain Factor Rules (see p. 64), a Mobile Structure automatically inflicts 150 points of damage to all terrain and terrain modifications within a hex it enters (see *Buildings*, p. 168, for the exception). As this occurs after the Mobile Structure has entered the hex, it cannot stop the unit from entering the hex as described under *Level Change (Ground)*, above.

### Off-Map Movement

Unlike any other unit type, Mobile Structures can be partially off the playing area. All hexes off the playing area are considered to be clear, at the Level of the hexes on the mapsheet, for movement purposes. For example, if the last hex before exiting a map is a Level 4, then the hexes off the map corresponding to that hex would be a Clear Level 4.

**Combat:** Any hexes of a Mobile Structure not directly on the playing area cannot be used in combat; they cannot make attacks or be the target of an attack. Whether a Mobile Structure is destroyed (see *Destroying a Mobile Structure*, p. 172) is based on the Mobile Structure hexes located on the playing area. If the Mobile Structure is considered destroyed, the entire Mobile Structure (including hexes off the map) are considered destroyed also; they cannot enter the playing area later in the scenario.

### FACING

Mobile Structures have no facing and can move in any direction unless blocked by impassable terrain, as shown on the Mobile Structures Movement Costs Table. However, at the end of a movement, all the hexes of the Mobile Structure must match up with the hex grid on the playing area.

In place of moving forward into a new hex row, a Mobile Structure may choose to spend all its movement to make a facing change. Mobile Structures may only change facing by one hexside per hex. The unit pivots around the centermost hex of the unit's template. The player simply finds the centermost hex of the unit (if more than one hex qualifies equally as the "centermost hex," the controlling player can choose which hex to use each time he makes a facing change), and keeping that hex centered, rotates the Mobile Structure in the desired direction until the hexsides of the unit once again line up with the hexsides of the mapsheet.

All restrictions on movement still apply for this facing change; if a unit cannot legally make the facing change, it cannot be done. This is tracked as the pivot move is made, so that if any portion of a Mobile Structure hex enters another hex as the player pivots the Mobile Structure template on the playing area, the terrain in that hex must be taken into consideration, even if the Mobile Structure hex will not occupy it once the pivot move is finished. Furthermore, if units occupying such hexes are "brushed" by a pivoting Mobile Structure, collisions may occur and must be resolved in the order that they happen (below). If multiple potential collisions appear to occur simultaneously, randomly determine the order of resolution.

### COLLISIONS

The following rules apply to collisions and Mobile Structures.

#### Ground Mobile Structures

If a Mobile Structure attempts to enter a hex occupied by another unit whose total height (including underlying terrain)

is at least three levels, a collision occurs (resolved as a charging attack; see p. 148, *TW*). Some examples are a 'Mech in a Level 1 hex, a grounded DropShip, a vehicle or infantry with VTOL MP airborne in the hex with an elevation corresponding to the Mobile Structure, another Mobile Structure and so on.

In all instances, the number of current hexes of a unit never takes into consideration the number of levels that unit may occupy.

See *Unit Displacement*, p. 173, for how to resolve displacements due to charging attacks.

#### Air Mobile Structures

Collisions against an Air Mobile Structure can only occur when another unit attempts to enter a hex occupied by a landed Air Mobile Structure. In this case, such a move is treated as a charge against a building (see p. 148, *TW*).

#### Water Mobile Structures

If a Water Mobile Structure attempts to enter a hex occupied by another unit, a ram automatically occurs.

#### Avoiding a Collision (Ground and Water Mobile Structures)

A unit that has not yet moved during the current Movement Phase can attempt to get out of the way of a Mobile Structure moving into the hex occupied by the unit. In order to get out of the way, the player controlling the target unit must make a successful Piloting/Driving Skill Roll (or Gunnery Skill, if no Piloting Skill exists; for infantry, use the Anti-'Mech Skill) just before the Mobile Structure enters the target's hex. A successful roll means the target unit may make its entire movement immediately, before the Mobile Structure continues its movement. Failure means the target remains in its hex (though a failed roll does not cause the target unit to fall). Units moved in this way have expended their movement by walking/cruising) and may not move again later in the Movement Phase. A failed roll means the unit is rammed by the Mobile Structure.

#### Damage to Targets (Ground and Water Mobile Structures)

The Mobile Structure automatically inflicts 100 points of damage, assigned in 10-point Damage Value groupings, against the appropriate column of the appropriate hit location table; this damage is reduced to 50 points if the charging unit is a Water Mobile Structure. For conventional infantry, this damage is assigned as though it originated from another infantry unit (see p. 216, *TW*); for battle armor, the damage is assigned as though it came from an area-effect weapon (see p. 219, *TW*).

**DropShips:** If more than one hex of a DropShip is involved in the charge, the 100 points of damage is applied for every hex involved.

**Mobile Structures:** The damage assigned to another Mobile Structure depends on the size of both structures. A Mobile Structure consisting of a greater number of current hexes charging a smaller Mobile Structure inflicts the standard 100 points of damage to every hex of the target structure it hits.

If both structures consist of the same number of hexes, both players roll 2D6, re-rolling any ties. The winner is considered the charging unit, and takes 50 points of damage to every hex involved, while the loser is the target and receives the standard 100 points of damage to every Mobile Structure hex involved.

INTRODUCTION

ADVANCED  
GROUND MOVEMENT

ADVANCED  
COMBAT

ADVANCED  
BUILDINGS

ADVANCED  
SUPPORT  
VEHICLES

GENERAL  
RULES

ADVANCED  
SUPPORT VEHICLE  
CONSTRUCTION

ADVANCED  
WEAPONS  
AND EQUIPMENT

INDEX

RECORD SHEETS



If the charging structure consists of a smaller number of hexes than the target, the target receives 50 points of damage to every Mobile Structure hex involved.

In all instances, damage is scaled for the type of Mobile Structure used as applied to buildings (see *Scaled Damage*, p. 126); this only applies to Fortress-type Mobile Structures. Also, damage is divided in half, rounded down (after scaling) if the Mobile Structure in question is a Water Mobile Structure.

### **Damage to a Mobile Structure (Ground and Water Mobile Structures)**

The damage applied to a charging Mobile Structure is based on the type of unit involved, as shown under *Damage in Charge Attacks* (see p. 148, *TW*), and is applied as a single hit.

**DropShips:** Damage from a DropShip is based on the size of the DropShip (see *Components*, p. 24, *TW*). A Small DropShip inflicts 25 points of damage, a Medium DropShip inflicts 50 points of damage and a Large DropShip inflicts 75 points of damage. If more than one hex of a DropShip is involved, that damage is applied to all hexes involved.

**Mobile Structures:** If the charging Mobile Structure consists of a greater number of hexes than the target Mobile Structure, 50 points of damage are assigned to every Mobile Structure hex involved.

If the charging unit consists of the same number of hexes as the target, determine who is the attacker and who is the target, as shown above.

If the charging unit consists of fewer hexes than the target Mobile Structure, 100 points of damage are assigned to every hex involved. In all instances, damage is scaled for the type of Mobile Structure used as applied to buildings (see *Scaled Damage*, p. 126); this only applies to Fortress-type Mobile Structures. Also, damage is divided in half, rounded down (after scaling) if the Mobile Structure in question is a Water Mobile Structure.

### **BUILDINGS**

Mobile Structures entering a building hex (along the ground for a Ground Mobile Structure, or while landing for an Air Mobile Structure) never enter the building itself. Instead, the MP cost (if any) represents the difficulty of demolishing the building in the hex; the sheer size and inexorable force of movement of even the smallest Mobile Structure reduces any building hex it enters to rubble. The height of a building has no impact on whether it can survive being turned into rubble by the movement of a Mobile Structure.

**Collapse:** If any units occupy a building hex that is turned to rubble in this fashion, resolve any falling, damage and unit displacement using the standard rules (see *Collapse*, p. 176, *TW*). A Mobile Structure always occupies a hex completely for stacking purposes, except as noted under *Stacking* (at right). For example, provided the underlying terrain level of the now-rubble hex allows it, a Mech could fall in a collapsed building, but still occupy the hex after the Mobile Structure has entered.

**Damage to Mobile Structures:** The damage applied to the Mobile Structure hex that entered a building hex is equal to that building hex's CF at the beginning of the current phase, divided by 10, multiplied by the number of levels of the hex. Once the damage from the type of building has been determined, first apply the scaling damage for the type of Mobile Structure used (see *Scaled Damage*, p. 126); this only applies to Fortress-type Mobile Structures. If the damage from a destroyed building hex destroys the entering Mobile Structure hex, damage is transferred (see *Hex Destruction*, p. 172).

**Prohibited Movement:** If a Mobile Structure is prohibited from entering a building hex due to the specific building type and/or classification located within that hex, the Mobile Structure can still expend the MP to attempt the move; in this case it automatically inflicts 150 points of damage against any such building hex it is attempting to enter (even if using the Expanded Construction Factor rules, all levels within the structure receive the 150 points of damage). Regardless of whether this damage destroys the building, reducing it to a rubble or ultra-rubble hex, the Mobile Structure does not actually enter the hex. If the building hex in question was reduced to a rubble or ultra-rubble hex, once the Mobile Structure has accumulated enough MP once more, it may move into the hex.

### **STACKING (GROUND MOBILE STRUCTURES)**

While many motive system linkages and tracked "feet" cover the entire base of a Ground Mobile Structure, the solid "bottom" of each unit does not begin until Level 3 above the level that interacts with the base terrain it crosses.

The hexes underneath a Ground Mobile Structure are treated as Light Woods for movement restrictions and LOS (see Movement Costs Table, p. 52, and Attack Modifiers Table, p. 116, respectively, *TW*). Any unit with a height equal to or less than Level 2 that can enter Light Woods can enter a hex underneath a Mobile Structure.

Beyond those restrictions, all stacking rules apply to the hexes underneath, as well as the hexes on top of the Mobile Structure.

**Prohibited Units:** If a vehicle is prohibited from entering a Light Woods hex and a Ground Mobile Structure moves into a hex occupied by such a unit, apply a 5-point Damage Value grouping hit to every location (only a single point of damage is applied to a rotor on a grounded VTOL) and automatically roll once on the appropriate Motive System Damage Table, as though the damage were coming in on the front arc.

This damage is applied every time a hex of a Ground Mobile Structure enters a hex occupied by such a unit, even in the case of multi-hex Ground Mobile Structures; as a large Ground Mobile Structure slowly moves over such a unit, damage is dealt by each Mobile Structure hex.

In the case of a Facing change (see p. 167), if more than one hex of a Mobile Structure appears to be passing over a hex occupied by such a unit, then double the damage noted above.

Such "trapped" units can use the Minimum Movement rule (see p. 49, *TW*) to exit from the bottom of a Ground Mobile Structure hex. If they are unable to use the rule to get out from underneath the Mobile Structure and/or enter a new hex underneath the Ground Mobile Structure in an effort to move toward a hex that will be out from under, the unit is trapped until the Ground Mobile Structure is finished passing over.

*In the Ground Mobile Structure Movement Diagram 1 (see next page), Dawson is controlling a Ground Mobile Structure with a Maximum MP of 3 on the BattleForce map. It has 4 hexes of depth, 5 hexes of width and is 6 Levels high (making it a total of 8 Levels, as the "bottom" of the Mobile Structure doesn't start until Level 3); the controlling player photocopied the Mobile Structure Template Sheet from the back of this rulebook, then cut out the size template needed to track movement on the playing area.*

*In place of moving the Mobile Structure onto the playing area, the players decided to simply place the Mobile Structure. Even though a path of 4 hexes of depth 1 river cuts underneath the*



• GROUND MOBILE STRUCTURE MOVEMENT DIAGRAM 1 •

Ground Mobile Structure, as this represents less than one-third of the Mobile Structure's width, this move is legal.

Before beginning the move, Dawson notes that the opposing player has a Yellow Jacket Gunship VTOL in Hex A at Elevation 8, which has moved, a Regulator Hovertank in Hex B, which has also moved, and a Thunder BattleMech in Hex C that has not yet moved. Dawson can either move by entering a new hexside, or he can expend all his movement to change his facing by a hexside. He decides he wants to change his facing so that he can line himself up for a move in the following turn. He also notes that since both hexes MA and MB on the Ground Mobile Structure are "equally centered," he can use either to pivot, changing from one turn to the next as he desires. After testing it for a moment, he decides that pivoting around Hex MB will line him up for what he wants to do. With all of that determined, he places the tip of a finger in the middle of Hex MB, then grasps the edge of the template with his other hand and starts to rotate it clockwise; the direction he's decided to change his facing.

Immediately Hex MC enters Hex A, and Hex MD and Hex ME enters Hex B. As there are units in both hexes, the player must resolve that situation right away; he randomly determines which to resolve first, coming up with VTOL. As the elevation of the Yellow Jacket is equal to the height of the Mobile Structure (the top level), a charge immediately occurs. 100 points of damage, in 10-point Damage Value groupings, is assigned. Despite the relatively robust armor of the Yellow Jacket, the controlling player of the VTOL knows that 100 points will completely destroy all the unit's armor and internal structure with damage left over; he realizes he

needed to be 1 elevation higher to avoid that grizzly fate. In return, the Yellow Jacket inflicts only 3 points of damage against the Construction Factor of Hex MC.

Next, they deal with the Regulator Hovertank in hex B. The vehicle is only 1 Level high and since the "bottom" of the Mobile Structure begins at Level 3, there is no charge. However, each hex of the bottom of a Ground Mobile Structure is considered light woods. Since a hover vehicle is prohibited from entering light woods, it immediately takes 5 points of damage to every location. However, the players note that hex MD and ME (as well as MF when Dawson continue to rotate the template) will all enter Hex B. As such, regardless of how many of the Mobile Structure's hexes enter Hex B, the damage is simply 15 points of damage to every location.

The 'Mech in Hex C, for this turn, is fine as even during the facing change, no Ground Mobile Structure hex even "brushes" the corner of Hex C. The players do note that the Ground Mobile Structure enters Hexes F and G, reduces those trees to rough (per the Mobile Structure Movement Costs Table, the trees do not cost any extra MP to enter); they also make note of any other clear hexes entered that are now rough as well.

In the Ground Mobile Structure Movement diagram 2 (see p. 170), during the Movement Phase of the following turn, the controlling player of the Regulator wins initiative and moves the Regulator first. Since it is "trapped" underneath the Mobile Structure all he can do is use the minimum movement rule to move the vehicle into Hex 2.

Once that movement is done, it is now Dawson's turn to move the Ground Mobile Structure again. Instead of a

INTRODUCTION

ADVANCED  
GROUND MOVEMENT

ADVANCED  
COMBAT

ADVANCED  
BUILDINGS

ADVANCED  
SUPPORT  
VEHICLES

GENERAL  
RULES

ADVANCED  
SUPPORT VEHICLE  
CONSTRUCTION

ADVANCED  
WEAPONS  
AND EQUIPMENT

INDEX

RECORD SHEETS





• GROUND MOBILE STRUCTURE MOVEMENT DIAGRAM 2 •

facing change this time, however, he decides to spend his 3 MP to enter a new hex row. As the Mobile Structure has no facing, it can move in any direction. As such, he expends 1 MP and moves into Hexes 1, 2, 3 and 4. As soon as Hex ME enters Hex 1, another 5 points of damage are applied to every location on the Regulator as it "sweeps past." Next, Dawson wants to move into hexes C, D and E. Per the Mobile Structure Movement Costs Table, a Level 1 doesn't cost any additional MP to enter. However, more than half of the hexes on a side attempting to change a level up must all be the same level. Since this is the case, Dawson can expend another 1 MP to enter the hill hex row; the far right hex of the Mobile Structure along the ME/MF side will be 'hanging' in the air, and so the bottom of that Mobile Structure hex is now at Level 4.

However, there is the 'Mech in Hex C to deal with. Its height is Level 3, and since that is the "bottom" height of the Mobile Structure "before" it enters the hex (i.e. before it changes a level up), a charge will occur. Yet the Thunder BattleMech has yet to move and so the controlling player immediately makes a Piloting Skill Roll. A successful roll! The controlling player heaves a sigh of relief at avoiding 100 points of damage and immediately takes his full turn of movement to avoid the Mobile Structure. Once the 'Mech has finished moving, Dawson then moves onto the hill. However, he cannot enter another hex row further onto the hill as there are only two Level 2 hexes and there must be three (more than half) for him to move up another level. He decides to leave off spending the last 1 MP and the turn is over.

## CARRYING UNITS

If a Mobile Structure is built with cubicles allowing it to carry other units (such as aerospace fighters, Small Craft, 'Mechs, vehicles and so on), the mounting and dismounting of such units follow the same rules as for a grounded DropShip (see *Carrying Units*, p. 89, TW); even if a Mobile Structure expends MP in a turn that a unit(s) dismounts, it still dismounts using the grounded DropShip rules. Provided the unit is not prohibited from entering a Light Woods hex, mounting and dismounting can occur from hexes underneath the Mobile Structure.

**Air Mobile Structures:** If airborne, use the launching/recovering rules for fighters (see *Launching/Recovering Fighters/Small Craft*, p. 84, TW).

**Water Mobile Structures:** Use the rules for mounting and dismounting infantry from naval carriers (see *Naval Carriers*, p. 224, and *Dismounting From Naval Carriers*, p. 225, TW) as guidelines for how to dismount all units from a Large Naval Support Vessel when it is not adjacent to a land hex, when it is submerged and so on.

## FLIGHT DECKS

Depending on the size of the Flight Deck, friendly fighters, Combat and Support VTOLs and Fixed-Wing Support Vehicles may land on a Mobile Structure with a Flight Deck. See *Flight Deck*, p. 312, in the *Advanced Weapons and Equipment* section for complete details on how to use a Flight Deck.

Enemy units attempting to land on a Flight Deck must apply an additional +2 modifier to the Landing Target Number (this is in addition to the +1 for a unit landing at unfriendly airfield; see p. 87, TW).



## COMBAT

The following rules cover the unique aspects of combat surrounding Mobile Structures.

### Line of Sight

Ground Mobile Structures rise a number of levels above the underlying terrain equal to their height in levels, plus 2, plus the underlying terrain of the hex in question. Given the nature of multi-hex units and the fact that a Mobile Structure can occupy different levels at the same time, two different hexes of a Mobile Structure may have different heights for LOS purposes.

**Air Mobile Structures:** Such units are treated as aerospace units for LOS purposes (see p. 99, *TW*).

**Water Mobile Structures:** Water Mobile Structures rise for half their height (round down) above the underlying water terrain they occupy (see Mobile Structure Types Table, p. 260).

### Specialized Attacks

Use all the rules for all the specialized attacks as described for Large Naval Vessel Support Vehicles, with the following modifications:

- When grappling a Ground Mobile Structure, any Ground Vehicle that follows all the other prescribed rules may attempt to grapple the unit.
- Instead of using the Boarding Action (Non-Infantry) rules, combat inside a Mobile Structure is resolved using the Combat Within Buildings rules (see p. 175, *TW*); all damage should be appropriately scaled, depending upon the type of Mobile Structure (see *Scaled Damage*, p. 126). Players can decide whether to use Combat Within Buildings rules or Infantry Vs. Infantry Actions rules (see p. 199) when resolving combat between infantry inside a Mobile Structure.

### Attacks by Mobile Structures

Per the Mobile Structures Construction Rules (see *Step 4: Install Weapons, Heat Sinks and Equipment*, p. 266), different weapons may be mounted at different levels in any given hex. To determine the height of a given weapon system, and thereby determine its LOS height, first determine the overall height of the hex and then subtract the number of levels down from the top. For example, a weapon is mounted in Level 7 of a 10-level Mobile Structure. With the hex in question on Level 1, the weapon would have a total LOS Height of 10 [10 (height of Mobile Structure) + 2 (undercarriage) + 1 (height of underlying terrain in that hex) - 3 (level of weapon below roof) = 10].

If a weapon is not mounted in a turret, then it has a firing arc corresponding to its designated hexsides (as determined during construction, or noted on the record sheet); see the Mobile Structure Hexside Arcs

Diagram for an example of non-turret mounted weapon arcs on a Mobile Structure.

**Turrets:** Weapons in a Mobile Structure's turret have a 360-degree arc of fire and are always presumed to be on the Mobile Structure's uppermost level.

**Underneath a Mobile Structure:** A Mobile Structure cannot attack units located underneath it.

### Attacks Against Mobile Structures

Attacks and damage against Mobile Structures are dealt with exactly like attacks against buildings (see *Attacking Buildings*, p. 171, *TW*), with the following modifications; see *Aimed Shots*, p. 120 for attacks against turrets on a Mobile Structure. Units outside a Mobile Structure cannot attack units inside a Mobile Structure, and vice versa.

If a hex takes damage equal to its current CF, the hex is destroyed, as are all weapons and equipment within that hex.

**Damage Threshold:** Every Mobile Structure hex has a Damage Threshold equal to the hex's current CF (at the start of that turn), divided by 10 (round up). If the Damage Value of any single Damage Value grouping exceeds the hex's Damage Threshold, a possible critical hit has occurred (see *Critical Hits*, p. 172).

**Armor:** If a Mobile Structure hex is armored, apply all damage received by the hex to the armor first, before applying damage to the Construction Factor of the hex in question (critical hits against a Mobile Structure hex cannot occur until all its armor is destroyed). Note that the Damage Thresholds do not apply to armor and only come into play once the armor has been removed.



• GROUND MOBILE STRUCTURE FIRING ARCS •

INTRODUCTION

ADVANCED  
GROUND MOVEMENT

ADVANCED  
COMBAT

ADVANCED  
BUILDINGS

ADVANCED  
SUPPORT  
VEHICLES

GENERAL  
RULES

ADVANCED  
SUPPORT VEHICLE  
CONSTRUCTION

ADVANCED  
WEAPONS  
AND EQUIPMENT

INDEX

RECORD SHEETS



**Hex Destruction:** If a Mobile Structure hex is destroyed, it collapses and will automatically damage all adjacent Mobile Structure hexes. Divide the current CF of every Mobile Structure hex adjacent to the collapsing hex by 2 (round down); divide the current armor of those hexes by 2 (round down) as well. The resulting number becomes the current CF of those hexes. This damage is modified for Scaled Damage rules; that is, it only applies to Fortress-type structures, where any such damage is halved (see p. 126).

In addition, every time a Mobile Structure hex is destroyed, roll 2D6 and add 1 for every hex of the unit destroyed during the scenario. On a result of 10 or more, a crew hit results. The crew of a Mobile Structure (as opposed to individual hex gunners, as discussed under *Critical Hits*; below) is treated like a DropShip crew (see p. 240, *TW*). For each such critical hit suffered, one crew box is marked off and a cumulative +1 modifier (for each such hit) is applied to all Gunnery Skill Rolls made by any hex of the Mobile Structure firing weapons. When all six crew boxes have been marked, the crew are dead; the Mobile Structure can no longer move, but all weapons that still have gunners can still fire (though with all the applicable modifiers for dead crew as noted above).

**Optional Damage Tracking:** If players wish to increase the lethality of a Mobile Structure, they can track damage using the Construction Factor (Expanded) rules (see p. 121), in which every level of every hex has a CF equal to the CF of the entire hex and damage is tracked per level. As this will radically increase how long it takes to destroy a Mobile Structure, all players must agree to this alternate rule before play begins.

## CRITICAL HITS

When a critical hit occurs, roll on the Mobile Structure Critical Hits Table to determine the exact effects, as described below. If a hex does not contain a specific type of item (even if it was destroyed in the same phase), then re-roll. If a hex does not contain any of the items listed on the Critical Hits Table, then the critical hit has no effect.

**Ammunition:** This result means the hex's ammunition explodes. Unlike a 'Mech, where only a single slot explodes, the hex loses all its ammunition. Count the total damage for all ammunition carried and apply the damage directly to the hex's Construction Factor. If CASE is mounted in a hex with an ammunition critical hit, divide the total damage by 10 (round down) and apply that value to the hex's Construction Factor. As usual, ammo that cannot explode (such as Gauss and Plasma) doesn't explode, but is still destroyed and cannot be used for the rest of the scenario.

**Gunners Killed:** A critical hit kills or severely injures the gunners for this hex. No weapons can be fired from this hex for the rest of the scenario.

**Gunners Stunned:** Damage from the critical hit disorients the gunners. During the following turn, the hex may take no actions (firing weapons and so on). After that, the hex may act normally. Multiple Gunners Stunned results in the same turn extend the number of turns for which these effects last.

**Turret Jam:** The turret rotation mechanism temporarily freezes, leaving the turret stuck in its current facing until the gunners spend a Weapon Attack Phase fixing the jam. The hex may not fire any weapons from that turret (though other weapons in that hex may still fire) while the jam is being fixed. Treat a second or subsequent Turret Jam critical hit—regardless of whether the gunner cleared the first jam—like a Turret Locks critical hit.

## MOBILE STRUCTURE CRITICAL HITS TABLE

2D6 Roll	Effect
2–5	No Critical Hit
6	Weapon Malfunction/Turret Jammed*
7	Gunners Stunned
8	Weapon Destroyed/Turret Locked*
9	Gunners Killed
10	Turret Jammed/Turret Locked*
11	Ammunition
12	Other**

\*When rolling these Critical Hit results, roll 1D6. On a result of 1–3, the effect left of the slash occurs; on a 4–6 result, the effect right of the slash occurs.

\*\*Various other equipment can be mounted in a Mobile Structure hex. On a roll of 12, the player should randomly determine what other equipment is available and destroy an item (provided other equipment exists in that hex to destroy).

**Turret Locks:** The turret rotation mechanism is severely damaged, locking the turret in its current facing for the remainder of the game. Additional critical hits of this type—or Turret Jam critical hits—have no further effect.

**Weapon Destroyed:** One weapon mounted in the damaged hex suffers major damage and ceases to function. The attacking player then rolls 1D6. On a result of 1–3, the player controlling the target unit chooses which weapon stops working. On a 4–6, the attacking player chooses which weapon stops working. If there are weapons in and outside of a turret in a hex, randomly determine which location the player will choose from. The hex cannot fire that weapon for the remainder of the game. If a weapon is destroyed that can explode (such as a Gauss rifle), it is treated as an ammunition explosion for the location where the weapon is mounted (see *Ammunition*, p. 125, *TW*).

**Weapon Malfunction:** This critical hit causes a weapon mounted in the hex to malfunction. If a hex has multiple weapons in that location, randomly determine which one takes the hit using the Weapon Destroyed rule above. The hex cannot fire that weapon until the malfunction is fixed. The gunners must spend one Weapon Attack Phase clearing the malfunction, during which the hex may make no weapon attacks. The gunners may only fix one weapon malfunction per Weapon Attack Phase.

## DESTROYING A MOBILE STRUCTURE

If all the hexes of an "interior" row of a Mobile Structure are destroyed (in effect splitting the Mobile Structure in half), the Mobile Structure is destroyed. The variable nature of Mobile Structure sizes may require the players to come to a consensus about when the unit is destroyed.

## Resolving Unit Destruction

Like Large Naval Vessel Support Vehicles, Mobile Structures are too large to instantly remove from play, depending on whether they are in a water hex(s) and/or units are on the roof. Use the Unit Destruction rules for Large Naval Vessel Support Vehicles (see p. 159) when resolving the destruction of a Mobile Structure under these circumstances.



## UNIT DISPLACEMENT

Mobile Structures modify the standard Unit Displacement rules in the following manner: The number of current hexes of a unit never takes into consideration the number of levels that unit may occupy.

### Displacement

A Mobile Structure is never displaced unless the unit entering a hex of a Mobile Structure is another Mobile Structure; this can occur due to a charging move, another displacement and so on.

In a situation where the Mobile Structure occupies only water hexes, if a Large Naval Vessel Support Vehicle enters a Mobile Structure hex, after resolving the charge effects the Mobile Structure is displaced normally.

**Unit Destruction:** If a unit other than a Mobile Structure or Large Naval Vessel Support Vehicle is displaced into a hex with a Mobile Structure (not the "roof" hex or underneath), and that hex is the only one it can legally enter, it is destroyed.

### Submerged/Surfacing Units

The following rules apply to the interaction of Mobile Structures and various submerging/surfacing situations.

**Surfacing Mobile Structure:** If any hexes of a Mobile Structure enter a water depth that another unit on the surface occupies, the results depend on the type of units involved.

Standard Combat Naval Vessels, Small and Medium Naval Vessel Support Vehicles and any Large Naval Vessel Support Vehicle of Template A size are stranded on the roof of the Mobile Structure hex, after resolving all charging damage (treat the vertical charge as a standard charge attack; see p. 148, *TW*; see *Collisions*, p. 167, for modifications to the charging damage applied to Large Naval Vessels); if the Mobile Structure hex contains a turret, it is automatically destroyed. The stranded unit can still fire its weapons, but cannot fire them at the Mobile Structure (though it can fire them at any units on the Mobile Structure, meaning it might accidentally hit the structure). If the stranded unit is carrying any other units, they can dismount using the appropriate rules. The unit remains stranded until the roof of the Mobile Structure submerges to Depth 1 and remains at that depth at the end of that Movement Phase, or until the hex occupied by the Mobile Structure is destroyed (no additional damage is applied to the stranded unit; it is simply back in the water and can move normally in the next turn). If the hex of the Mobile Structure occupied by the stranded unit moves into a non-water hex and then the hex is destroyed, the stranded unit is automatically destroyed as well.

Large Naval Vessel Support Vehicles of Template B to E size, after resolving charging damage, must make a Piloting Skill Roll with a +4 modifier (along with all other standard modifiers). A successful roll means no additional damage is applied. A failure means the unit partially capsized; apply a Crew hit and roll twice on the Motive System Damage Table (see p. 193, *TW*), and also three times on the Ground Combat Vehicle Critical Hits Table (see p. 194, *TW*). If the unit involved has the Submersible Chassis and Controls modification, then its controlling player only rolls once on the Motive System Damage Table and once on the Ground Combat Vehicle Critical Hits Table, though it still takes a Crew hit. After all damage is resolved, displace the unit as appropriately as possible (the displaced unit cannot occupy a hex occupied by the Mobile Structure; the players will need

to adjudicate this situation, using common sense, and may roll the dice to help determine the location if there are any issues). A displaced Large Naval Vessel can enter a non-water hex (in which case it has run aground; see p. 154), but cannot be displaced more than 1 non-water hex away from the water; in this instance, the Mobile Structure is displaced as appropriately as possible (it may run aground as well, in which case apply appropriate damage; see *Water Mobile Structures*, p. 165). Even if the displaced unit is a Ground Mobile Structure, running aground damage should be applied, but it is not stuck or immobile.

If a Mobile Structure surfaces below another Mobile Structure, apply standard charging damage (see p. 167). The unit displaced is the Mobile Structure consisting of the smaller number of current hexes. If both units consist of the same number of current hexes, both controlling players roll 2D6 (re-rolling ties). The loser is displaced. If any structure runs aground due to the displacement, use the rules described above. In all instances of displacement, neither unit can occupy the same hex afterward.

**Surfacing Large Naval Vessel Support Vehicle:** If any hexes of a Template B- to E-size Large Naval Vessel Support Vehicle rise to a depth that a Mobile Structure on the surface occupies, the results depend on the size of the two units involved. After determining damage, resolve the displacement as described above, treating the Large Naval Vessel as a Mobile Structure for purposes of which unit consists of more current hexes.

**Surfacing Non-Mobile Structure or Large Naval Vessel:** If a unit other than a Mobile Structure or Large Naval Vessel (such as a unit with UMU MP, a Combat Naval Vessel, a submarine and so on) surfaces into a hex occupied by a Mobile Structure, resolve charging damage as normal, but the unit remains at the same depth as before it entered the Mobile Structure depth; neither unit moved.

**Completely Underwater:** If any of the situations described above arise, but both units are completely underwater, halve (round down) all charging damage; all displacement rules still apply.

**Hover and WiGE Vehicles:** If either vehicle type is over a water hex occupied by a Mobile Structure (or Large Naval Vessel Support Vehicle), the hover or WiGE units can still move and fire normally. However, if they move off the edge of the Mobile Structure or Large Naval Vessel, they must take the difference in height into account for MP expenditures. If a Hover Vehicle changes more than 2 hex levels when moving from a hex occupied by the Mobile Structure or Large Naval Vessel to a water (or land) hex, the vehicle falls (see *VTOL Rotor Destruction*, p. 197, *TW*). If it hits a water hex, the falling Hover Vehicle is automatically destroyed.

### Accidental Falls From Above

If a unit accidentally falls onto a Mobile Structure hex (or hexes), assign damage normally (see p. 152, *TW*).

In the case of a Mobile Structure falling onto another Mobile Structure, use the size difference as shown in the Submerging/Surfacing rules, at left, to determine which unit will be displaced after all damage is assigned; a Mobile Structure can never be stranded on another Mobile Structure, regardless of differences in size.

A Mobile Structure takes damage equal to 10 points times the levels fallen to all its hexes.

INTRODUCTION

ADVANCED  
GROUND MOVEMENT

ADVANCED  
COMBAT

ADVANCED  
BUILDINGS

ADVANCED  
SUPPORT  
VEHICLES

GENERAL  
RULES

ADVANCED  
SUPPORT VEHICLE  
CONSTRUCTION

ADVANCED  
WEAPONS  
AND EQUIPMENT

INDEX

RECORD SHEETS



# INTO THE FIRE

Jason Schmetzer



**ORBITAL INSERTION**  
**BROMHEAD**  
**CAPELLAN MARCH, FEDERATED SUNS**  
**21 NOVEMBER 3071**

The hull of the shuttle vibrated out of tune with the bulky combat armor Subaltern Gloria Riordan wore. She rested her gauntlet against the hull and noted the discordant tones. Must have something to do with relative densities of the metals, she surmised. The thin armor-weave gauntlet of her Asterion battlesuit was far more dense than the thin, barely-armored hull of the shuttle. She looked at her gauntlet as the tone changed against the hull. The atmosphere was thickening, which meant the relative density of shuttle hull was rapidly losing place on her list of priorities.

"Listen up," she called, using the maniple frequency even though the tough helmet of her Asterion was thrown back and open. The noise in the shuttle's bay was more than she cared to shout across, no matter what the Force Sergeant had taught her about the "bellow of command" back at A-School on Cyrtan.

"Two minutes to jettison," she said. "We're linking up with a platoon of Third Taurian armor on the ground in ten minutes." She flashed both hands at her troopers, first two fingers raised and then ten. The comm systems built into the combat armor would transmit her words clearly to the other troopers of her irregular-sized squad, but the habits of infantry training were difficult to break. *And if you're trying to hide your signature*, she thought, *what then?* Though she had

to admit that walking most of a ton of powered metal around didn't lend itself to stealth.

The shuttle lurched and dropped, taking with it any sense of security Gloria's stomach had gained since they'd launched from the DropShip. She snapped her visor down and chinned for the cockpit channel. "What the hell, Cornet?" she barked at the pilot.

"Fighters," the pilot gasped. "Shut up."

Gloria cut the channel and signaled the maniple to seal up. The other four troopers slapped their visors down and checked the shoulder restraints that locked them into the jettison pods. They'd practiced low-grav insertions on Cyrtan before this deployment, but not enough, and never under fire.

"Fighters," she told them after she checked to see that each of them had a green seal. "We'll shake 'em and get down okay, you wait." Three of the troopers flashed her a thumbs-up, but the fourth, Madison, sat mute. She frowned.

Acceleration kicked her in the seat of her suit and then the shuttle shuddered and lurched to the side. Red warning lights flashed to life inside the bay and the indicator for the cockpit channel burned to life inside Gloria's helmet. She chinned the accept stud.

"—out, for Christ's sake, get out!"

The shuttle slammed her against her restraints again, kicking her

shoulder painfully, and there was a scream across the channel before the carrier wave cut out and Gloria was left with silence inside her helmet. She listened to herself breathe once, then twice, and then twisted enough to see the cockpit hatch. A solitary red light burned in its center.

Vacuum.

A cold knot formed in the middle of Gloria's stomach. "Saints preserve us," she whispered, and then her mind snapped into focus.

"We're out of here, troops," she shouted, cutting her chin on the channel-switch pad. "Drop NOW-NOW-NOW!" She let go of the handhold beside her seat and raised her armored fist, held it up, showed her troops, brought it down. The glass over the switch shattered beneath the armor of her gauntlet.

And then the shuttle came apart.

Pistons drove her dropseat out of the shuttle's bottom, shoving it into the already-deformed airflow as the shattered vessel fell into the thickening atmosphere. Her seat tumbled, whirled, spun. Gloria didn't know how high they were, didn't know if they'd be safely into the thicker air and slow enough that they wouldn't burn up, didn't know if they'd be too high and bounce off to float in orbit until Bromhead embraced them again.

She didn't know where the fighters were.

She didn't know where she was.

She fell.

✕

"I can see the ground," Madison called finally.

Gloria turned herself in her descent until her heads-up display painted Madison's suit with a green-slashed icon. He was roughly half a kilometer away and slightly lower than she was. He'd be down first.

"Any signs of contact?" she asked.

"You could say that," Madison said, and flashed her a compressed video feed. A small window opened on the inside of her helmet, and Gloria's already-tight stomach lurched. They weren't coming down anywhere near the landing zone. That had been chosen safely away from the battlefield, to give them time to link up with the armor team that was detailed to move them toward the Davion depot that was their target. The LZ was cold, safe. Almost as easy as training, she'd called it during the brief.

They were coming down on the battlefield.

BattleMechs roamed the low-visibility canyons beneath them. The final layer of cloud haze cleared away and her Asterion's small computer began to identify units. Two companies of Third Taurian BattleMechs were playing a cat-and-mouse game with a short company of Davion defenders, but they were outclassed. These Davy boys knew the ground.

The still-warm hulks of three Taurian 'Mechs attested to that.

Gloria swore and flashed her transponder. "Let's get down there and assemble," she said. "Everyone try and get closer before we hit." She closed the channel without waiting for an acknowledgement and concentrated on her falling.

The Taurian Defense Force had little experience deploying powered armor, and even less in deploying them from the air. Gloria's squad had been in the middle of an airborne training evolution when the orders came through for deployment into the Federated Suns salient, but they'd picked



up a lot. Soldiers had been dropping from the skies to engage their enemies for more than a thousand years, and that experience, even in the Periphery, was not lost to antiquity.

Of course, old-time airborne troopers didn't wear a full ton of armor around themselves, Gloria thought.

The shuttle's dropseat formed a partial parafoil that allowed the rapidly falling Asterions to guide their descent, and a small fuel bunker in the center of their seat supplemented a low-opening parachute and the dropseat's integral jump jets to slow them just before landing. One of Gloria's instructors at the drop school likened the experience of airborne battle armor to "the longest zip-line deployment in history. Fall for a hundred kilometers, slow down in the last one. One way or another." They'd all laughed at the gallows humor on Cyrtan.

Gloria wasn't laughing now.

The altimeter bounced a whisker laser off the ground every second, updating her with the distance to solid earth. At a kilometer her parafoil broke away and freed the chute, which tugged her upright and aligned her boots—and the jets on her armored hooves—toward the ground. At 750 meters those jets began to fire, and fire.

And fire.

And then the ground fired back. Hutchins had time for a fast curse before a line of glittering tracers from a Davion *JagerMech* erased his suit from the sky. Madison swore and cut away his chute, trusting his jets to bring him down safely. Gloria opened her mouth to stop him, but he'd already fallen away before she could get a word out.

"Bloody fool," she whispered, watching him in her HUD. Without the chute's stabilizing influence, the Asterion would tumble and it would be up to the trooper to keep his jets pointed down. She didn't trust herself to be able to do that, not even with a Battle-Mech hunting them. On the ground she could hunt back, but she was no cloud dancer.

There was a grunt across the maniple channel when Madison hit the ground, but that was all. Gloria directed her view down and saw the icon for his suit bouncing across the terrain in ninety-meter sprints, trying to get closer to where she would come down. Juresh and Falcone were closer to her, still dangling from their chutes. The *JagerMech* turned away, content with its sole kill, and concentrated on the Taurian 'Mechs moving toward it.

Fifty meters. The crackle of weapons fire began to penetrate the insulation of her suit, and a PPC flashed by close enough to raise the hair on her forearms.

And then she was down. Madison was waiting, the bull's-horned head of his suit bent toward the ground. One hoof-shaped boot came down and pawed at the soil, tearing the blue-green grass apart. Gloria slapped the release that cleared her suit from the drop apparatus and straightened. A toggle inside her right gauntlet brought the big barrel of the mid-size recoilless rifle over her armor's shoulder. The weapon checked out green.

She stamped her own foot and wished again that the suit's designers had put a valve on the minotaur-head helmet to blow steam. Moments later, Juresh and Falcone appeared, both of them with weapons ready.

Gloria looked at her maniple, past the hole where Hutchins would have stood. She reached up and stroked the rifle's thick barrel. Madison growled, a low sound that curled through the Asterion's comms like an angry phantom.

"New plan, boys," she said. "Let's go kill something."

× ×

It took the local TDF commander a minute or two to get the comm codes sorted out, but once he did, he wasn't happy to have the support of a maniple of battle armor, not when it didn't fit into his tidy little plan of battle. "Where the hell are my tanks, Subaltern?"

Gloria was in the middle of leading her maniple across the field of fire between a hunkered-down Davion *Nightstar* and a pair of Taurian *Cataphracts*. She and Madison had already sprinted across, but Juresh caught the tail-end of a barrage of cannon fire from the nearest *Cataphract* and tumbled down. His suit rolled, crushing soil and rock alike, before he regained his footing and sprinted toward the rest of the maniple. Falcone made it across without incident, though Gloria winced when she saw the portside Gauss rifle on the *Nightstar* track him for a handful of steps.

"We missed the LZ, Brigadier," she said. "We're here now, and the tanks aren't. Where do you want us?"

"The tanks were supposed to flush the damn Davions!" the officer shouted. Gloria frowned and called up a tactical map. The brigadier's *Marshal* was half a klick behind the engagement zone, surrounded by a lance of heavy 'Mechs. "I needed them to get into the warrens and drive the bastards out."

"Sir," she started, but then ducked as an explosion rocked across the area. When she looked up there was only one *Cataphract* left and the *Nightstar* was striding forward, both arms raised to deliver the same coup de grace to the remaining Taurian 'Mech. She snarled inside her helmet and stabbed a hand at the Davion 'Mech. "Back in a few, sir," she said. "We're a little busy here." She chinned the circuit closed and got her troopers' attention.

"That big bastard right there," she said, pointing to the *Nightstar*. "He's all alone and that *Cataphract* could use some help."

Juresh's suit managed to slump into a pout. "That's the fool that shot me, Subaltern," he said. "Besides, that's an assault 'Mech. That's not our brief, is it? I thought we were here for a supply point?"

Gloria spread her hands. "You see any skimmers, Juresh? See any way for us to hump our ton-heavy asses across forty kilometers unless we carry ourselves?" She waited half a heartbeat and then clapped her gauntlets together. The metal vibrated for a moment.

"We're here," she said. "We screwed the drop, missed the LZ. We're in the pot now, and it's time we start to get some back." She rubbed her hands together, knowing that their external pickups would hear the gravelly scratch of metal and composite rubbing against itself. "Who wants to go kill something?"

"Oh, killing is good," Madison said. "I was hoping for a nice, deadly *Locust* or something, maybe one of those killer *Wasps*. But if all we've got is a pansy little *Nightstar*, well... I guess it'll do."

Gloria laughed. "All right, then." She leaned around the boulder they'd sheltered behind and took a look at the ground, thought for a moment. Her eyes judged the *Nightstar's* angle of advance, looked across to see where the *Cataphract* was headed, waited while her mind worked the angles. She bounced a ranging laser off the *Nightstar's* bulbous chest, did a little math. It might work, she thought.

"Here's the plan," she said, and sketched it out quickly. The maniple got it fast, each of them looking at the lay of the land and the angles for themselves. Madison chuckled as the *Nightstar* stumbled with one foot in a crater, but the other two kept silent. She asked for questions, got none, and then took a deep breath. Two years of training, two hundred light years from home. Hutchins already gone. The *Cataphract* already gone.

"Move," she said.

In two steps each of them was around the boulder and sprinting toward the *Nightstar*. The doctrine had been relentlessly drilled into them almost since the first day they were issued the battlesuits: four steps forward, one to the side, three forward, two to the side, four forward, again and again and again, with variations added in case the enemy caught the pattern. With myomer-assisted legs and high-energy servos, the Asterion's zig-zag covered a lot more ground than a regular infantryman, and the maniple made good use of it to close the two hundred meters to the *Nightstar* in just over twenty seconds. Gloria kept her sights on the Davion 'Mech and held down the trigger. The recoilless rifle belched fire as the autoloader slammed each shell into the barrel, but she didn't watch to see how many hit. She wasn't trying to shoot the damn thing to death, just distract it.

"It's fixated on the 'Mech," Falcone called. Gloria risked a look around, saw Juresh and Madison right behind her, Falcone out to the side. Falcone laughed, freely as a child does. "I can't believe he's ignoring us."

Gloria looked over at him again, getting ready to tell him to clear the circuit. There was a snarling hash of static in the radios, a screech, a flash of silver. She blinked.

Falcone was gone.

"Gauss round," Juresh growled.

Gloria screamed into the loneliness of her helmet and lurched forward. Her vision blurred and tinged red at the edges as she held down the firing stud on her rifle, waiting for death to come. It had followed them all the way from the Concordat, on the JumpShip, the DropShip, even the shuttle and this damnable dirtball of a Davion world.

Her Asterion slammed into the *Nightstar's* thick ankle joint and bounced off. Gloria shook herself. Her vision cleared, as did her mind, and she realized she was sitting on her ass beneath ninety-five tons of pissed-off Davion. She lurched to her feet and stamped her hoof. Madison and Juresh were already

at the other leg, climbing, using the sharp forward edge of their Asterions' boots and the powerful claws built into their gauntlets to scale the BattleMech's body. The 'Mech, as if sensing its enemies, lurched into motion. Gloria leapt, reached, clutched.

She was aboard.

"Knees, hips and head," she whispered. The anti-'Mech commando's prayer. She'd learned it her third day of basic training, all the way back on Jamestown. She'd known the words, and then she'd learned the skills. Now she'd been given the tools. All that remained was her; all that remained was the will.

She climbed.

Gloria bypassed the *Nightstar's* awkward reverse-canted knees and kept climbing. Juresh had stopped and pulled a shaped-charge from the built-in pouch on the Asterion's thigh, but she knew this only peripherally. She had her target. Her HUD kept a picture of him in the corner, so she saw him stab his arm into the narrow joint as the *Nightstar's* knee flexed, saw the joint close on his arm, heard him scream as the limb was amputated as cleanly as a scalpel might have done it by the unrelenting mass of the 'Mech's armor. He fell away.

She climbed past the jutting hip joint, timing herself, getting a feel for the 'Mech's stride. She climbed, crouched, balanced for a instant, and leaped, using the *Nightstar's* own upward thrust to help loft herself to the 'Mech's angular torso. Her claws scratched impotently before they finally caught, and her boots found purchase.

"Fire in the hole," Madison called from the *Nightstar's* other hip. Gloria let go with her left fist, drew back, and slammed it into an already-torn patch of armor. The powerful fist broke through just far enough for her to find purchase before the charge exploded, shaking the *Nightstar's* entire frame and threatening to pop Gloria's shoulder from its socket. She heard Madison's call as he dropped clear and moved to cover, where he could snipe with his rifle.

Gloria climbed higher.

"Clear field!" a strange voice shouted. She jerked her head to the side, saw the *Cataphract* barely ninety meters away, weapons leveled. The *Nightstar* lurched as the MechWarrior tried to move on the shattered hip. Gloria snarled, tore her hand loose, and climbed. This was hers.

Hers.

"Gloria!" Madison called. "Get out of the way!"

The *Nightstar's* canopy was thick transpex, heavy enough to shed BattleMech-scale weaponry, but it stood little chance against her rage. She straddled the 'Mech's bullet-shaped nose and drew back, screaming inside her helmet, and then slammed her horned head against the canopy. The thick composite cracked—and cracked—and cracked as she struck it again and again, until she could force her hand through the hole, deeper, just deep enough, until her grasping claw found something soft and gently resistant, and tore.

She was still screaming, still raging, as the dead BattleMech fell.

\*\*\*

DANGER



DK

*A spotter, Scott Stansbury, uses his Swift Wind's electronics suite to call in an artillery strike.*

The following rules cover a wide variety of advanced options for game play.

## ADVANCED SCATTER

The usual rules for determining scatter (such as for bombs in *TW*, artillery within this section, and so on) are presented in a way to quickly implement during a game. However, that ease of use means that a wily opponent can place himself very near a target hex for such an attack, knowing that under the usual scatter rules there's no chance he'll take damage. The following Advanced Scatter rules ensure that any hex can be hit, because a scattering shot can strike anywhere; this eliminates the loophole and injects a little more realism into the game. These rules can be used for any action that normally calls for the use of a scatter diagram.

Per standard scatter rules, determine the MoF of the action. Next, to determine the exact hex location of the failed action, first roll one die and compare it to the standard Scatter Diagram (see p. 182) to find the direction of the scatter. Next, if the MoF was 1 or 2, roll a second die that represents the distance away from the target hex (in hexes). If the MoF was 3 or 4, roll 2D6 to determine the exact hex hit. If the MoF was 5 or 6, roll 3D6 to determine the exact hex hit. And so on.

Next, count two hexsides to the right, starting with the hexside opposite the original target hex. Roll a final set of dice equal to the number of dice rolled for the MoF that represents the distance away from this hex (in hexes), in the direction of that new hexside, where the attack actually lands.

### ADVANCED ALTITUDE BOMBING SCATTER

When using the Altitude Bombing Scatter Diagram (see p. 245, *TW*), if players wish to use advanced scatter, the following rules apply.

Per standard scatter rules, determine the MoF of the action. Next, to determine the exact hex location of the failed action, roll 1D6: on a result of 1–3, start on the left hexside (marked “1–2” on the Altitude Bombing Scatter Diagram); on a 4–6, start on the right hexside (marked “5–6” on the Altitude Bombing Scatter Diagram). Next, if the MoF was 1 or 2, roll a second die that represents the distance away from the target hex (in hexes). If the MoF was 3 or 4, roll 2D6 to determine the exact hex hit. If the MoF was 5 or 6, roll 3D6 to determine the exact hex hit. And so on.

Next, once you travel the distance to the target hex determined by the dice roll above, if you started on the left hexside of the Altitude Bombing Scatter Diagram, turn two hexes to the right; if you started on the right hexside, turn two hexes to the left. Finally, roll a set of dice equal to the number of dice rolled for the MoF to determine (in hexes) how far away, in the direction of that new hexside, the attack actually lands. Subtract a value from that die roll result equal to the number of dice rolled. For example, a MoF of 5 requires a 3D6 roll. In this case, for the final distance rolled after determining the new direction, the player would roll  $3D6 - 3$  to find the final target hex.

*A player is targeting Hex 0808 on a map with an artillery attack and has missed by a MoF of 5. First the player rolls 1D6 and gets a result of 3, meaning the direction of travel for the initial scatter will be 2 hexsides to the right of the numbered hexside of Hex 0808. Next, the player rolls 3D6 (required by the MoF of 5), with a result of 7; the player counts out 7 hexes to*



Hex 1512. The player then rotates two hexes to the right from the hexside opposite the direction of travel from the original target hex, which in this case is 2 hexsides to the right of the numbered hexside; rotating 2 hexsides results in the hexside that is 2 hexsides to the left of the numbered hexside. Finally, the player rolls 3D6 one more time and gets a result of 5. This means the final target is Hex 1014; damage is applied in that target hex (and adjacent hexes, if appropriate).

## ARTILLERY

Artillery can provide a force with useful long-range fire support. Unlike the real world, where artillery is often the decisive force in combat, *BattleTech* artillery is only a supplement to conventional forces, though it can still be very effective if used well. BattleMechs are the kings of the battlefield, however, and even the best artillery strikes will rarely be more effective than a good 'Mech lance.

Like LRMs, artillery may be fired directly or indirectly. However, artillery is most effective when fired indirectly. These rules therefore approach artillery from the point of view that such weapons most often will be used indirectly; rules for firing artillery directly appear under *Direct-Fire Artillery* (see p. 185).

**Definition of Indirect:** Any unit more than seventeen hexes away from the target is considered indirect for purposes of artillery fire, even if the artillery unit is on the same mapsheet as the target and has a clear line of sight to the target hex. An artillery unit can fire indirectly at a target less than seventeen hexes away if there is no LOS (see *Indirect fire at Targets Seventeen Hexes Or Less Away*, p. 185).

If the attacker is seventeen hexes or closer to the target, and LOS exists to the target, use the *Direct-Fire Artillery* rules (see p. 185).

**Area-Effect Weapon:** Artillery attacks are area-effect weapons, and so all rules that apply to such weapons also apply to artillery attacks. This includes applying all standard damage to the infantry as well as the carrying unit for mechanized battle armor.

### SEQUENCE OF PLAY

When artillery is used, modify the normal sequence of play as follows:

1. Initiative Phase
2. Targeting Phase
3. Movement Phase (Ground)
4. Movement Phase (Aerospace)
5. Indirect Artillery Attack Phase
6. Weapon Attack Phase
7. Physical Attack Phase
8. Heat Phase
9. End Phase

### ARTILLERY NOT DIRECTLY ON THE PLAYING AREA

Prior to placing their units on the playing area, players may decide to assign artillery units that will not be located directly on the playing area to one or both sides during game setup. This choice may be dictated by the scenario being played, or the players can simply agree to add this element to their game.

Players should determine the relative location of any artillery not located on the playing area. Any unit mounting an artillery weapon that the player is not directly fielding on the playing area sets up behind that player's home map edge (see *Set-Up*, p. 256, *TW*). For example, if the friendly forces set up on the north side of the playing area, artillery units not on the playing area would set up north of the map. Designating a specific location for artillery is important because hit locations of many units (including 'Mechs, vehicles, grounded aerospace units and so on) are determined by the direction from which the artillery fire arrives.

Players must also determine the artillery unit's distance from the playing area, expressed in units of 500 meters (the length of one ground mapsheet). Players may place an artillery unit any distance from the playing area up to its maximum range (see *Artillery Ranges Table*, p. 181; this information is also found on the *Weapons and Equipment Tables* in the back of this rulebook, included for ease of reference).

Players may place units further away than that, if they wish, but the artillery will be unable to affect the playing area without moving. The further away from the playing area an artillery unit is placed, the longer it takes for its shells/missiles to reach the target. Also keep in mind that such ranges are to a single mapsheet, not the playing area. For example, in a given game the playing area consists of 9 mapsheets laid in a square (3 x 3) and the controlling player of a Long Tom artillery unit places it at its maximum range behind his side: 30 mapsheets (15,000 meters or 15 kilometers). This means the artillery could only hit the middle mapsheet of the first row of three on his edge (30 mapsheets range) without moving. The artillery could not hit the mapsheets in the first row to the left or right of the middle mapsheet (31 mapsheets), or the other 6 mapsheets of the playing area, as the two rows of three mapsheets would be at 31 mapsheets and 32 mapsheets, respectively. Yet the closer the unit is placed to the playing area, the greater the likelihood that its position could be overrun and the weapon destroyed or captured if the battle goes against that side (see *Artillery and Rolling Maps*, below). Players must therefore strike a balance when determining where to place such units. If the players cannot decide on a range, position the artillery unit(s) at a distance of half its maximum range from the battlefield.

### Artillery and Rolling Maps

Rolling maps turn a fixed battle into a mobile affair, where opponents, once they've determined the general direction of an artillery attack, can send units to search out those positions and attack them directly (as opposed to simply using their own artillery as counter-battery fire; see p. 186). If using the *Rolling Maps* rule (see p. 214), modify the placement of artillery not directly on the playing area as follows.

Divide the playing area in half, with each player's home edge on opposite sides. For example, looking at the Number 2 map placement diagram (see *Laying Out Mapsheets*, p. 264, *TW*), if the top and bottom of that diagram are the home edges for two players, the middle map would have a line drawn down its center, bisecting the playing area into two equal halves. That line extends into the distance in both directions. When placing artillery not directly on the playing area, a player can place those units in any direction (back, left or right) from the playing area, provided it is on his own side of that line. If a

INTRODUCTION

ADVANCED  
GROUND MOVEMENT

ADVANCED  
COMBAT

ADVANCED  
BUILDINGS

ADVANCED  
SUPPORT  
VEHICLES

GENERAL  
RULES

ADVANCED  
SUPPORT VEHICLE  
CONSTRUCTION

ADVANCED  
WEAPONS  
AND EQUIPMENT

INDEX

RECORD SHEETS



player is fielding multiple artillery units, they need not all be in the same direction, but can be placed in any direction, provided they all fall on “their side” of that line.

For each artillery unit placed, the player must pre-determine the type of mapsheet each artillery unit occupies, as well as the exact hex(s) on those mapsheets (this is in addition to the distance and direction from the playing area). All such artillery units start a scenario as hidden units on their respective mapsheets (see *Hidden Units*, p. 259, *TW*).

During game play, if the target hex of an artillery attack was in the LOS of an opponent unit in the turn in which the shell/missile arrives (the actual targeted hex, not a hex the shot might scatter to if it misses), then the opponent may know the general direction of the artillery attack. The controlling player of any units that fall into this category makes an immediate Gunnery Skill Roll, using the unit’s base Gunnery Skill Rating, applying a +5 modifier. Additionally, consult the Artillery Modifiers Table (at right) to determine any additional modifiers. For example, a ‘Mech with a Gunnery Skill Rating of 2 would make a Gunnery Skill Roll against a Modified Target Number of 6 [2 (Gunnery Skill Rating) + 5 (standard modifier) – 1 (Artillery Modifiers Table modifier) = 6]. While multiple units that qualify (i.e. have LOS to the target hex) may make such a roll, a unit may make only one such roll a turn, regardless of how many shell/missiles might arrive in a given turn, or how many of those target hexes are in LOS.

If any Gunnery Skill Roll is successful, the controlling player of the artillery attack must announce a direction, based on the hexside of the target hex where the artillery landed. Draw a line from the center of that target hex to the center of Hex 0909 on the “mapsheet” occupied by the attacking artillery unit and then announce that hexside. This may need to be sketched out on a piece of paper, but it should be done in a way that the “exact” mapsheet off the playing area remains a mystery.

The opponent that witnessed the attack can then determine if he wishes to send units in that general direction, using the Rolling Maps rule, to try to find the artillery unit and attack it directly. If the player does use the Rolling Maps rules to seek out an opponent’s artillery, whenever a mapsheet is placed on a player’s “side” of the playing area (determined by bisecting the playing area as noted above), the controlling player of that side should automatically place a mapsheet of his choice. This is done so that when the controlling player places the mapsheet where his artillery is actually located (pre-determined before the game began), he does not move from a random mapsheet placement to suddenly choosing a specific mapsheet for placement and giving away the fact that his artillery is on that that specific mapsheet.

Alternately, players can predetermine the total number of maps required to extend the playing area out to where any artillery is located, then select that number of mapsheets (either using the Mapsheet Tables, as noted below, or using any form the players agree upon) and place them in a pile next to the playing area. As new maps are needed to extend the playing area, the player then selects from the pile, knowing that map X is the actual location of a given artillery unit and that he’ll select map X when it comes to placing that mapsheet onto the playing area.

When placing mapsheets in this fashion, the players should determine before any play begins how difficult or easy they wish to make such mapsheet choices. It would be all too easy for a player to throw up the most difficult terrain possible as he lays out new mapsheets to try to stop an opponent from locating his

artillery; if a particular playing group agrees to that type of play, they can go right ahead. However, players may wish to use the Mapsheet Tables instead (see p. 263, *TW*), where a player chooses a new mapsheet to lay out that is similar in terrain to the mapsheet already in play.

### Pre-Designated Hexes

If all players agree, before beginning play, each side using artillery units not placed directly on the playing area may secretly choose up to 5 hexes on the playing area as pre-plotted target hexes. Artillery fire on a pre-plotted hex automatically hits after the shell/missile flight times have elapsed.

Note that this number is for a playing area composed of four maps. If players are using a truly large area, they may wish to alter this number: a total of 5 hexes per side fielding artillery units for every four mapsheets used (for example, a twelve-mapsheet playing area would allow 15 pre-plotted hexes per side). However, regardless of the size of the playing area, no player can place more than 5 pre-plotted hexes per mapsheet (an area seventeen hexes long by fifteen hexes wide). These limits apply regardless of how much artillery is in use by either side.

## ARTILLERY MODIFIERS TABLE

Condition	Modifier
For every 2 points of Gunnery Skill less than 4 possessed by the spotting unit*	-1
For every 2 points of Gunnery Skill greater than 4 possessed by the spotting unit*	+1
Adjusting fire: for each previous shot fired at the target hex by the artillery unit*	-1

\*See *Artillery Spotters*; Round any fractions down.

## TARGETING

During the Targeting Phase of a turn, a player wishing to make an indirect artillery attack may select and record the map hex numbers that he wishes his artillery to fire on that turn. Indirect artillery fire can only be directed at hexes, not individual targets. Players may direct artillery fire at hexes not under the direct observation of a friendly unit; however, this fire may not be adjusted (see *Artillery Spotters*, p. 181). Each artillery unit that a player controls may target a different hex or the same hex; if an artillery unit mounts multiple artillery weapons, each weapon can be fired at the same or different hexes at the controlling player’s discretion. Record the turn in which each piece fired, each target hex, and the turn in which each fired shell will land. The turn in which a shell will land equals the current turn number plus the shell’s time in flight, as shown on the Indirect Artillery Flight Times Table (see p. 181).

### Airborne Targeting

A unit mounting an Arrow IV (no other artillery weapons may be used to make an airborne attack) may make an artillery attack against ground hexes while airborne; direct-fire airborne artillery attacks cannot be made. When making such an attack, follow all the standard rules for a unit on the ground making an artillery attack, with the following additions.



If using Low-Altitude Movement, apply the following additional modifiers: if the attack is made from Altitudes 4-6, apply a +1 modifier; if the attack is made from Altitudes 5-9, apply a +2 modifier; attacks from Altitude 10 or higher cannot be made. If an artillery attack is made from Altitudes 1-8, the attack lands the turn after it was fired; if it is made from Altitude 9, the attack lands two turns after it is fired.

If on a High-Altitude Map, an airborne unit can only make artillery attacks against ground hexes if in the Ground Row, Row 1, Row 2, Row 3 or Row 4 hex rows; no attacks against ground targets may be made if the attacking unit is in a Space/Atmospheric Interface Hex, or in a space hex. Regardless of what hex row the attacking unit occupies, apply a +3 to-hit modifier. In addition, apply to-hit modifiers through atmospheric hexes (see *Effects of Atmosphere*, p. 236, TW) to the flight time, with each hex representing a mapsheet; this is one of the few times when a weapon can fire further than its maximum range and still inflict damage. For example, a unit is firing an Arrow IV from Hex Row 3. Each atmospheric hex represents 6 hexes, which is translated to mapsheets for artillery. This means that the distance from the attacker to a ground target hex is 18 mapsheets; out of range for the Arrow IV, though the weapon can still be fired (it also will have a flight time of 3 turns). If firing an artillery weapon beyond its maximum mapsheet range, apply an additional +1 modifier for each mapsheet beyond that range. For the Arrow IV (Inner Sphere technology), that means an additional +10 modifier is applied to the to-hit roll; this will automatically miss, but the final modified target number will help determine the Margin of Failure and how far the attack will scatter before applying damage to a target hex(s) (see *Determining Hits*, p. 182).

In both instances of movement on High-Altitude or Low-Altitude maps, the target hex must be on the mapsheet corresponding to the hex occupied by the attacking unit. If using the *Aerospace Units on Ground Mapsheets* rules, the target hex can be anywhere on the playing area within a weapon's firing arc, except for the hex directly underneath the airborne unit.

**Homing Missiles:** Arrow IV homing missiles (see p. 354) cannot be fired beyond their maximum hex range, as they will automatically miss with no effect.

### Artillery Spotters

Artillery spotters can improve the accuracy of artillery fire in the following two ways (note that both of these situations can occur simultaneously, providing both benefits):

If the target hex was in the LOS of a friendly unit (the spotter) at the end of the Movement Phase of the turn in which the artillery attack was launched, and the same friendly unit has the target hex in its LOS in the turn in which the shell/missile arrives, then a modifier, as shown on the Artillery Modifiers Table, can be added to any new attack. As soon as that friendly unit does not have LOS to the target hex at the end of a Movement Phase in which an artillery shell/missile is either launched or landed, any new artillery attack made loses that bonus.

The player manning an artillery unit may attempt to adjust subsequent fire to home in on its target hex by noting how far off from the target hex and in which direction its shot landed. If there is a spotter with LOS to the target hex as described above, the attacker may adjust subsequent fire at that hex.

Each attack adjusted in this way modifies the to-hit number for that artillery unit by -1, as shown in the Artillery Modifiers Table. Again, remember to take into account the proper attack and when that attack will arrive on the target mapsheet when applying the modifier.

In both instances, if an artillery spotter makes an attack of its own in the same turn it is spotting for an artillery attack, apply a +1 modifier to all the spotting unit's attacks, as well as a +1 modifier to the artillery attack made that turn; as above, note the turn when that shot will arrive on the mapsheet containing the target hex. That is the shot where the modifier for such an attack will apply. If the spotting unit makes no attacks, do not apply these additional modifiers.

*A Long Tom artillery unit will be firing 7 shots in 7 turns against a single hex, using the same spotter. The Long Tom is 16 mapsheets away from the mapsheet containing the target hex. Looking on the Indirect Artillery Flight Times Table, this means the shell will take three turns before hitting the target hex. A unit friendly to the Long Tom*

## ARTILLERY RANGES TABLE

Type	Maximum Range (in mapsheets)
Arrow IV Missile (Inner Sphere)	8
Arrow IV Missile (Clan)	9
Thumper	21
Sniper	18
Long Tom	30
Cruise Missile/50	50
Cruise Missile/70	90
Cruise Missile/90	120
Cruise Missile/120	150

## INDIRECT ARTILLERY FLIGHT TIMES TABLE

Distance from Battlefield (in mapsheets)	Artillery† Flight Time (in turns)
Less than 1*	0
1-8	1
9-15	2
16-21	3
22-26	4
27-30	5
Cruise Missile‡ Flight Time (in turns)	
1 + (Number of mapsheets ÷ 5, round down)	

\*See *Direct-Fire Artillery*, p. 185.

†Arrow IV, Thumper, Sniper and Long Tom

‡Cruise Missile/50, Cruise Missile/70, Cruise Missile/90 and Cruise Missile/120

INTRODUCTION

ADVANCED  
GROUND MOVEMENT

ADVANCED  
COMBAT

ADVANCED  
BUILDINGS

ADVANCED  
SUPPORT  
VEHICLES

GENERAL  
RULES

ADVANCED  
SUPPORT VEHICLE  
CONSTRUCTION

ADVANCED  
WEAPONS  
AND EQUIPMENT

INDEX

RECORD SHEETS



(the spotter), with a Gunnery Skill that provides a  $-2$  modifier has the target hex in its LOS at the end of the Movement Phase during Turn 1. The controlling player begins to make an artillery attack during the Indirect Artillery Attack Phase each turn, starting on Turn 1. Meanwhile, the spotting unit has kept the hex in LOS through Turns 1, 2, 3 and 4. During the Indirect Artillery Attack Phase of Turn 4, the first shell arrives on the mapsheet. The controlling player can now apply a  $-1$  modifier to his next attack, which will occur during the Indirect Artillery Attack Phase of Turn 4. However, the attacks made during Turns 2 and 3, which will arrive onboard during Turns 5 and 6, will not receive that benefit. The first shell to receive that benefit will arrive on Turn 7.



• SCATTER DIAGRAM •

### Determining Hits

During the Indirect Artillery Attack Phase, players announce artillery attacks due to land in that turn and resolve the effects of their fire. Artillery fire may or may not land in the targeted hex. Except for fire against a pre-designated artillery target hex, determine whether or not an artillery attack hits its target hex. Use the attacking unit's Gunnery Skill as a base to-hit number and apply a standard modifier of  $+7$ , plus the appropriate modifiers from the Artillery Modifiers Table.

Roll 2D6. If the result equals or exceeds the modified to-hit number, the attack hits the target hex; otherwise, the attack scatters. To determine where the scattered attack lands, first determine the Margin of Failure (MoF). For each 2 MoF beyond the first 2, the player missed by an additional die.

To determine the exact location, first roll one die and compare it to the Scatter Diagram to find the direction of the scatter. Next, if the MoF was 1 or 2, roll a second die that represents the distance away from the target hex (in hexes) where the attack actually lands. If the MoF was 3 or 4, roll 2D6 to determine the exact hex hit. If the MoF was 5 or 6, roll 3D6 to determine the exact hex hit. And so on.

Once an artillery unit hits its target hex (not any hex to which a shot scatters), it will automatically hit that hex every time it targets that hex for the remainder of the scenario; the same rules for spotting apply (see *Artillery Spotters*, p. 182), so that only those shots

fired after the shot strikes the hex will automatically strike the hex. The exception to this rule is if the unit in question making the artillery attack expends MP after the hex has been hit, in which case that hex can no longer be hit automatically (this means airborne units firing Arrow IV missiles can never automatically hit a hex once they've hit it). In all instances, players keep track of which hexes can be struck by which units, as artillery units cannot use each other's "auto hit" hexes.

### DAMAGE

The amount of damage a unit takes from an artillery attack depends on two factors: the base damage value of the shell/missile, and the distance between the unit and the detonation hex when the shell/missile explodes.

The base Damage Value of a shell/missile is the damage the shell/missile inflicts on any unit within a hex struck by the shell/missile. Reduce the damage by 10 points for each hex of distance between the target hex and the affected unit. For example, reduce the Damage Value by 10 for a unit in an adjacent hex, by 20 for units two hexes away, and so on.

Cruise missiles reduce the damage by 25 points for each hex of distance between the target hex and the affected unit.

All units and structures occupying a hex hit by an artillery attack take full damage from the attack. Group damage from artillery into 5-point Damage Value groupings and apply to the target. To determine direction of attack for hit locations for artillery off the playing area, consider the artillery piece to be in the center hex of the map edge beyond which it lies. Thus, if the artillery is located to the north of the mapsheet on which the battle is taking place, resolve hit locations as if the attack originated in the center of the north edge of that mapsheet; the attack direction against targets in adjacent hexes is determined as though the attack came from the target hex. If an attack is made from on the playing area, regardless of size, determine the direction of the attack by drawing a line between attacking and target hexes. See the Artillery Ordnance Table for the Damage Values of each artillery type against the target and adjacent hexes; many types of ordnance have additional effects, and so players are encouraged to look over the ordnance they have in mind by reading the relevant entry in the *Advanced Weapons and Equipment* section, starting on p. 274.

Additionally, in the target hex only (never in any adjacent hexes), this damage is also applied vertically into the elevations above the target hex (meaning an airborne VTOL in a target hex that is at a low enough elevation may still take damage). In the target hex, for each subsequent elevation above the level of the underlying struck hex, reduce the damage by 10 points (25 for cruise missiles) and apply that damage to the next elevation; this is done until there is no more damage to apply to a higher elevation. This type of vertical damage does not apply to buildings or Mobile Structures, which follow their own rules (see below). Also, such vertical damage is not inflicted twice against units that occupy more than one level (such as a standing 'Mech).

Any player using an artillery weapon must select the ordnance type during the Targeting Phase of the turn when the round/missile is fired. While the players can determine any method that works for them, it is suggested that a player controlling artillery write down his selection of ordnance—along with the intended target hex—without revealing it to his opponent; this information will be revealed in the turn the attack arrives onboard.



• RADIUS DIAGRAM •

INTRODUCTION

ADVANCED  
GROUND MOVEMENT

ADVANCED  
COMBAT

ADVANCED  
BUILDINGS

ADVANCED  
SUPPORT  
VEHICLES

GENERAL  
RULES

ADVANCED  
SUPPORT VEHICLE  
CONSTRUCTION

ADVANCED  
WEAPONS  
AND EQUIPMENT

INDEX

RECORD SHEETS



## ARTILLERY ORDNANCE TABLE

Ordnance Type	Damage Type	Weapon Type Damage Values (Radius)				
		Long Tom	Sniper	Thumper	Arrow IV	Cruise Missile
Air-Defense Arrow (ADA)*	F	—	—	—	20	—
Arrow IV Homing Missile*	AE	—	—	—	20	—
Arrow IV Non-Homing Missile*	AE, F	—	—	—	20/10 (R1)	—
Cluster*	AE, F	20/10 (R1)	15/5 (R1)	10/1 (R1)	20/10 (R1)	—
Copperhead*	AE	15 (R0)	10 (R0)	5 (R0)	—	—
Flechette*	AE, AI	*	*	*	—	—
High-Explosive (standard)	AE, F	25/15/5 (R2)	20/10 (R1)	15/5 (R1)	—	—
Minefield Rounds						
Thunder Active-IV*	AE	—	—	—	20 (R0)	—
Thunder FASCAM (Inner Sphere)*	AE	25 (R0)	20 (R0)	—	20 (R0)	—
Thunder FASCAM (Clan)*	AE	25 (R0)	20 (R0)	15 (R0)	30 (R0)	—
Thunder Vibrabomb-IV*	AE	—	—	—	20 (R0)	—
Non-Explosive Rounds**						
Illumination*	—	(Radius 3)	(Radius 2)	(Radius 1)	(Radius 4)	—
Inferno IV-Missiles*	AE, H, AI	—	—	—	(Radius 1)	—
Laser-Inhibiting Arrow Missile*	—	—	—	—	(Radius 1)	—
Smoke*	—	(Radius 1)	(Radius 1)	(Radius 1)	(Radius 1)	—
Cruise Missiles						
Cruise Missile/50	AE	—	—	—	—	50/25 (R1)
Cruise Missile/70	AE	—	—	—	—	70/45/20 (R2)
Cruise Missile/90	AE	—	—	—	—	90/65/40/15 (R3)
Cruise Missile/120	AE	—	—	—	—	120/95/70/45/20 (R4)

\*See additional rules for the specific ordnance in the *Advanced Weapons and Equipment* section.

\*\*The effect radius describes the area affected by a non-explosive shell. For example, an illumination round fired by a Long Tom has an effect radius of 3, so it affects the target hex, as well as any unit within 3 hexes of the target hex. Ordnance with an effect radius of 0 affects only the target hex.

**Buildings, Mobile Structures and Grounded DropShips:** A building or Mobile Structure in a hex hit by artillery attacks uses the area-effect weapons rules to resolve damage (see *Area Effect Weapons*, p. 172, *TW*).

If a unit occupies a non-Fortress or -Castles Brian building hex, or a non-hardened building hex of any other classification (see *Advanced Building Classifications*, p. 114), in a hex damaged by an artillery attack, full damage is applied to the unit as well as the building hex. If a building, Mobile Structure or Grounded DropShip hex is higher than both the underlying level of the target hex and a unit/building occupying a hex that would be damaged by an artillery attack, and that building, Mobile Structure or Grounded DropShip hex lies along the LOS between the target hex and the hex occupied by the unit, and the building, Mobile Structure or Grounded DropShip hex completely absorbs the damage assigned to it by the artillery attack without being destroyed, the unit/building receives no damage. If, however, the attack destroys the building, Mobile Structure or Grounded DropShip, divide the damage not applied to the building, Mobile Structure or Grounded DropShip by the Damage Value applied to that hex, then multiply that percentage by the Damage Value that would be applied to the hex occupied by the target unit/building to determine the actual damage applied (round down in all cases). For example, a 40 Damage Value cruise missile artil-

lery attack (the third "ring" of damage of a Cruise Missile/90) is applied to a standard building hex with a current CF of 19, which destroys the building. The target unit in the adjacent hex behind the building would receive 7 points of damage [21 (damage not absorbed by building) / 40 (damage value assigned to the building hex) = .525 x 15 (Damage Value assigned to the target unit's hex) = 7.875 (rounding down to 7)].

**Levels (Hills):** If a hill is higher than both the underlying level of the target hex and a unit/building occupying a hex that would be damaged by an artillery attack, and that hill lies along the LOS between the target hex and the hex occupied by the unit, the unit/building receives no damage. If using the Terrain Factor Rules (see p. 64), and the damage from an artillery attack reduces the level of the hex so that it no longer is higher than the unit in the hex that avoided damage, then use the formula as described under *Buildings* at left to determine the actual damage assigned to the unit/building.

**Large Naval Vessel Support Vehicles:** Large Naval Vessel Support Vehicles have their own rules for dealing with area-effect weapons (see p. 159).

**Water:** Use the rules for area-effect weapons against buildings (see p. 172, *TW*) when resolving the damage from an artillery attack if the target hex is a water hex, and if units and/or buildings are occupying such water hexes. If the target hex is not a water hex and an adjacent hex is a water hex, no damage is applied to



completely submerged targets in that adjacent hex; in the case of a Mech standing in Level 1 water, the damaged is applied using the Punch Hit Location Table.

### DIRECT-FIRE ARTILLERY

While most players use artillery for indirect attacks, an artillery-equipped unit has several attack options for directly targeting enemy units.

In all instances, start with the attacker's Gunnery Skill as a base to-hit number, with a +4 to-hit modifier; apply all other modifiers as noted below.

All direct-fire artillery attacks are made during the Weapon Attack Phase.

**Cruise Missiles:** Cruise missiles cannot be used to make any of the following attacks.

**Flight Times:** As noted on the Indirect Artillery Flight Times Table (see p. 181), any direct-fire artillery attack lands in the same turn it is made.

#### Direct Fire

To make a direct artillery attack, the artillery unit must have line of sight to the target hex, and the target hex must be no further than seventeen hexes away. Do not modify the to-hit number for range, target movement, the terrain of the target hex or an immobile target. The base to-hit number is modified normally for the attacker's movement and for firing through (not into) woods and for other terrain features.

A direct-fire artillery attack is made during the Weapon Attack Phase and has no time in flight.

If the attack hits the target hex, the shell/missile inflicts standard artillery damage, including damage to adjacent hexes, as well as any other effects, if applicable. If the round misses its target, it scatters as described in *Targeting* (see p. 180), but only 1D6 is rolled to determine distance; i.e. the MoF is not applied.

**Minimum Range:** When making a direct-fire artillery attack, if the target is within six hexes of the attacking unit, the attack cannot be made (this minimum range is ignored when making Pointblank Attacks; at right).

#### Indirect Fire at Targets Seventeen Hexes or Less Away

Artillery units may make an indirect attack on a unit that is less than seventeen hexes away if there is no LOS to the target hex.

Modify the to-hit number for attacker movement during the turn in which it fires.

**Note:** If firing at targets more than seventeen hexes away, use the standard rules for indirect artillery fire.

#### Bore Sighting

Bore sighting is a specialized version of a direct-fire attack. It enables an artillery weapon to make a Careful Aim attack (see *Careful Aim*, p. 84). All the rules for Careful Aim apply, and the unit can begin bore sighting when the target is further than seventeen hexes away. However, the weapon may not fire until the target is within seventeen hexes. If the artillery fires before the target is within seventeen hexes, resolve as a standard indirect artillery attack, and all accumulated Careful Aim modifiers are lost.

To make bore sighting attacks with one or more artillery units, the controlling player must secretly write down which units are bore sighting and specify the target for each unit. When the attacker uses his artillery weapons, he turns over

the piece of paper and shows the defending player which units are attacking, how long they have been bore sighting and which defending units are being attacked.

### Pointblank Attacks

Only hidden onboard artillery units that have not previously fired or moved in a scenario can make pointblank artillery attacks. The artillery unit makes its pointblank shot from hiding as described on page 259 of *Total Warfare*, with the following additional rules.

Only high-explosive rounds can be used in a pointblank attack, and the attack must be aimed at the hex the target unit occupies; it cannot be aimed behind the target unit or at any other hex within the attacking unit's LOS.

If the attack hits, it is treated as a hit from a direct-fire ballistic weapon, resolved against the unit's facing relative to the attacking unit. An additional 5 points of artillery damage applies to all other units in the target's hex (treat as an area-effect weapon if these other units include infantry).

If the to-hit roll fails, the round scatters. Re-roll the scatter direction if the result calls for the attack to scatter toward the attacking unit or the two hexes adjacent to the attacking unit.

### Flak

Players can use an artillery unit located on the playing area (any ordnance on the Artillery Ordnance Table with a "F" Damage Type) to fire directly at airborne ground units (VTOL Vehicles, WIGEs and units expending VTOL MPs such as infantry) as well as airborne aerospace units. The player must declare that he is firing at the unit, and must have a valid line of sight to the target unit. Resolve the attack as normal for an artillery direct-fire attack, per the rules in *Direct-Fire Artillery*, at left, (if the target is an airborne aerospace unit, the minimum number of hexes does not apply). Apply a +3 to-hit modifier; the only other modifiers applied are for the firing unit's movement and current damage, as well as woods/jungle, if any are intervening. Additionally, if firing at an airborne aerospace unit on a Low-Altitude Map, apply a +1 modifier for each 3 altitudes above the first 3; i.e. 1-3 altitudes provide no modifiers, 4-6 altitudes provide a +1 modifier, 5-9 altitudes provide a +2 modifier and Altitude 10 provides a +3 modifier. Flak shots from artillery cannot be made into any hex row beyond Ground on the High-Altitude Map.

**Low-Altitude and High-Altitude Maps:** Damage against units on Low-Altitude and High-Altitude maps is determined normally, but no damage is applied to any adjacent hexes and/or altitudes.

When determining scatter on a Low-Altitude or High-Altitude map, divide the distance scattered by 6 (round down) to determine the distance in hexes scattered. If the shot does not scatter into a new hex, the shot inflicts no damage. If it scatters into a new hex, then apply damage per the standard rules to any units in that new hex.

**Aerospace Units on Ground Mapsheets:** Determine damage to flying units (including non-aerospace units, such as VTOL Vehicles, or units expending VTOL MP) using the *Aerospace Units on Ground Mapsheets* rules (see p. 91, *TW*) in the target and adjacent hexes as normal.

In addition, in the target hex only (never in any adjacent hexes), this damage is also applied vertically into the elevations above and below the target hex (meaning an airborne VTOL in

INTRODUCTION

ADVANCED  
GROUND MOVEMENT

ADVANCED  
COMBAT

ADVANCED  
BUILDINGS

ADVANCED  
SUPPORT  
VEHICLES

GENERAL  
RULES

ADVANCED  
SUPPORT VEHICLE  
CONSTRUCTION

ADVANCED  
WEAPONS  
AND EQUIPMENT

INDEX

RECORD SHEETS



the target hex that is at the correct elevation above or below the target elevation may still be damaged). In the target hex, for each subsequent elevation above and below the elevation of the target, reduce the damage by 10 points and apply that damage to the next elevation; this is done until there is no more damage to apply to a higher elevation. This type of vertical damage can potentially damage non-airborne targets (buildings, trees, other units) if the elevation of the damage equals the elevation of the target. However, such vertical damage is not inflicted twice against units that occupy more than one level and/or elevation (such as a standing 'Mech, Large Fixed-Wing Support Vehicles and so on).

Shots that missed scatter as normal but explode at the elevation of the target unit (they do not fall to the ground and explode).

### COUNTER-BATTERY FIRE

It is possible to launch attacks against an opponent's artillery. Such attacks are called counter-battery fire and can only be launched by a player's own artillery, be it on or off the playing area.

Counter-battery fire can be initiated only after an enemy artillery attack strikes the map on a hex that is in the LOS of at least one of the defender's units. From that point on, counter-battery attacks may be launched by the defender against that particular enemy artillery unit.

Counter-battery fire is resolved in the same way as standard indirect artillery attacks. If the target of an attack is not on the playing area, however, players must use slight variations on those rules to determine a successful attack. The range to the target (in mapsheets) is determined by adding together the distance from the playing area to the attacking and defending artillery units, including the mapsheets that make up the playing area.

Counter-battery fire is always aimed directly at the "hex" the enemy artillery occupies. If the attack roll succeeds, the attack hits the target hex. If the attack roll fails, the shot scatters according to the standard rules.

**Cruise Missiles:** Cruise missiles can be used to make counter-battery attacks. However, counter-battery attacks against a unit making a cruise missile attack cannot be made.



*A Grenadier and Rottweiler face off against a squad of Death Commando Ying Longs.*

*A Long Tom high-explosive round is fired against an enemy artillery position. The attacking artillery piece is 5 mapsheets away from the playing area, while the target artillery piece is 7 mapsheets distant. The battle itself is taking place on a 12-mapsheet area (4 x 4), so the total distance is 16 mapsheets, which means the shell will arrive at the target hex after three turns in flight.*

### PLANETARY CONDITIONS

The following apply when using these specific Planetary Condition rules with artillery.

#### Weather Conditions

When using Weather Planetary Conditions with artillery spotters (see p. 181), use the Visual Range Table (see p. 221) to modify the distance to which a spotter can visually see a target hex.

Additionally, apply any Missile to-hit modifiers to all artillery attacks, depending upon the type of Weather condition in use (see the Weather Conditions Table, p. 36)

#### Atmospheric Pressure (Density)

If using the Atmospheric Pressure (Density) Planetary Conditions (see p. 54), apply the following rules. Apply Atmospheric Range reductions after Gravity Range reductions.

- Vacuum: Increase range (in boards) by 20%, round down.
- Trace/Thin Atmosphere: Increase range by 10%, round down.
- High Atmosphere: Decrease range by 10%, round down.
- Very High Atmosphere: Decrease range by 20%, round down.

#### High/Low Gravity

If using the High/Low Gravity Planetary Conditions (see p. 55), apply the following rule: divide the ranges in each row of the Artillery Ranges Table by the gravity (in terms of fractions of the Terran Standard gravity of 1), and round down. Flight times continue to use the Artillery Flight Time Table, but with the new range.

*A game is being played on a world with Trace Atmosphere and a High Gravity of 2.2. Player A has a Long Tom that he's looking to fire, but must adjust the range. Player A divides the range by gravity first, 30 mapsheets / 2.2 = 13.63, rounded down to 13 mapsheets. The Trace Atmosphere then extends range by 10%, 13 mapsheets x 1.1 = 14.3, rounded down to 14 mapsheets. Since flight times do not change, the Long Tom can reach its new maximum range in 3 turns.*

## BATTLE ARMOR WEIGHTS

While the simplicity of 1 ton per trooper for battle armor makes for quicker, easier game play when dealing with Infantry Carriers (see p. 223, TW), it does not accurately reflect the vast differences between the ultra-light weight PA(L)/Exoskeletons all the way up to massive assault battle armor.

To better reflect such differences, see the Advanced Battle Armor Weights Table. Note that while it is much more realistic, it also makes the heavier weight classes much more difficult to carry



## ADVANCED BATTLE ARMOR WEIGHTS TABLE

Weight Class	Tons of Cargo Space Occupied	Battle Armor Units (total occupied cargo space)		
		4 troopers	5 troopers	6 troopers
PA(L)/Exoskeleton	.25 tons	1 ton	1.25 tons	1.5 tons
Light	.5 tons	2 tons	2.5 tons	3 tons
Medium	1 ton	4 tons	5 tons	6 tons
Heavy	1.5 tons	6 tons	7.5 tons	9 tons
Assault	2 tons	8 tons	10 tons	12 tons

with standard vehicles found in various Technical Readouts, as most such dedicated infantry-carrying designs are based on the 1 ton per trooper rule.

## BATTLEFIELD WRECKAGE

For simplicity, in standard-rules play, when a unit is destroyed it is removed from the playing area and has no further effect on the battlefield. However, this is not very realistic, as many units are large enough they would indeed have an effect on the battlefield even after their destruction. The Battlefield Wreckage Table provides a set of conversion rules for what a hex (or hexes, in multi-hex units) turns into after the destruction of a given unit type. If there is a dash in the Terrain Type column, then the unit doesn't translate into any type of terrain and is ignored after it is destroyed (as in standard-rules play).

These terrain modifiers stack with other terrain modifiers, and so the destruction of a 'Mech that creates a rough hex in what was originally a light woods hex actually converts it to a light woods/rough hex. However, if the hex type created by the destruction of a unit already exists in that unit's hex, the terrain remains the same; that is, the destruction of a 'Mech in a rough hex would result in a rough hex.

**Crashing:** Crashing airborne units destroyed in a crash also create their appropriate terrain type in the hex(s) involved; airborne units destroyed while airborne break up enough not to affect ground mapsheets.

**Water:** Any unit that occupies a water hex when it is destroyed will convert the bottom of the water hex into the new terrain type shown on the table; such destroyed units do not modify the Depth levels of the water hex.

## BATTLEFIELD WRECKAGE TABLE

**Tonnage:** In all instances, a unit must be 40 tons or greater to modify terrain upon destruction.

Unit Type	Terrain Type
'Mech	Rough
ProtoMech/Infantry	—
Combat Vehicles	Rough
Medium Support Vehicles	Rough
Large Support Vehicles/ Super-Heavy Vehicles	Ultra Rough
Rail	Ultra Rough
Fighters/Small Craft	Rough
DropShips/Mobile Structure	Ultra Rubble



*A destroyed Stingray adds its metal carcass to the battlefield.*

INTRODUCTION

ADVANCED  
GROUND MOVEMENT

ADVANCED  
COMBAT

ADVANCED  
BUILDINGS

ADVANCED  
SUPPORT  
VEHICLES

GENERAL  
RULES

ADVANCED  
SUPPORT VEHICLE  
CONSTRUCTION

ADVANCED  
WEAPONS  
AND EQUIPMENT

INDEX

RECORD SHEETS



## BOARDING ACTIONS (NON-INFANTRY)

While the infantry vs. infantry actions (see p. 199) provide an abstracted system for large-scale infantry to fight over control of a unit, the following rules allow for units to use “standard” movement and combat, with minimal changes, to resolve boarding and fighting inside large-scale units.

**Legal Targets:** Only Large Naval Vessel Support Vehicles and grounded DropShips can be the target of this type of non-infantry boarding action; Mobile Structures use the *Combat Within Buildings* rules (see p. 175, *TW*), to resolve such situations.

### MOUNTING THROUGH A BAY DOOR (INTO A CARGO BAY)

An enemy unit can attempt to mount a DropShip or Large Naval Vessel through one of its bay doors (see p. 209, *TM*); note that such mounting places the unit inside the transport bays and/or cargo bays (all treated as a cargo bay for purposes of these rules).

All the standard rules for a friendly unit mounting a DropShip apply (see p. 89, *TW*), with the following additions:

- Any attempts to mount through a bay door can only be made against a hit location that has at least a portion above water; if a hit location is completely submerged, this rule cannot be used to mount through any bay doors in that location.
- Unlike a friendly unit mounting a DropShip, any bay doors (including cargo doors) may be used.
- A mounting enemy infantry unit must make an Anti-Mech Skill Roll, applying a +2 modifier. If the roll is a success, the infantry unit has mounted into the bowels of the target unit. The infantry can either be used to make attacks in the cargo bay (see *Weapon Attacks in Cargo Bay*, at right) or the infantry is removed from the playing area and an infantry vs. infantry action begins (see p. 199). If the roll fails, the infantry remain in the last hex they occupied.
- A mounting enemy 'Mech must make a standard Piloting Skill Roll, applying an additional +4 modifier. If the roll is a success, the 'Mech has mounted into the bowels of the target unit and can make attacks during the Weapon Attack Phase (see *Weapon Attacks Against Cargo Bays*, below); if the roll fails, the 'Mech remains in the last hex it occupied. As with a friendly unit attempting to board a DropShip, if the 'Mech's controlling player gets a 2 on the Piloting Skill Roll, the door is damaged and cannot be used for the rest of the game; in this instance, the 'Mech does not mount the unit, however.
- A ProtoMech may attempt to mount a DropShip or Large Naval Vessel using all the same rules as a 'Mech, but in place of a Piloting Skill Roll, the ProtoMech makes a specialized weapon attack (using its Gunnery Skill Rating as the Base Target Number), applying a +3 modifier (unlike a 'Mech, no modifiers for damage apply).
- A ground vehicle may attempt to mount a DropShip or Large Naval Vessel using all the same rules as a 'Mech, but must apply a +5 modifier to the standard Driving Skill Roll.
- VTOLs, WIGEs, Small Craft, fighters and naval units cannot mount an enemy unit using this rule.
- If the hit location containing the bay door does not have any armor remaining, apply a -2 modifier to all rolls for mounting through a door.

- Only a single attempt per unit per turn can be made, regardless of available MP.
- Any enemy unit that has mounted through a bay door may follow the exact rules as noted above for dismounting, except apply a -2 modifier. If all bay doors have been damaged since mounting (meaning that units cannot use those doors), the unit cannot dismount.
- If Planetary Conditions rules are in use (see p. 28), any condition that adds a modifier to a Piloting Skill Roll applies, even if the unit does not enter a hex. For example, Deep Snow would not apply, as the hex the unit is attempting to enter (a Large Naval Vessel) would not be filled with snow. However, Heavy Falling Snow would apply. Players should use their best judgment on which planetary conditions might affect this Piloting Skill Roll; roll a die to resolve any disagreements.

### WEAPON ATTACKS IN CARGO BAYS

Any weapon attacks (whether from a friendly or enemy unit) in the cargo bay of a DropShip or Large Naval Vessel use the following rules.

A player can nominate one of four targets of attacks in a cargo bay each turn: the unit itself, cargo within the cargo bay, transport bays (non-active units; see *Transport Bays (Expanded)*, p. 217), and active units (those that are not in a transport bay; that is, they are mounting or dismounting from the DropShip or Large Naval Vessel and/or are attacking the enemy unit in the cargo bay). The specifics of each are discussed in detail below.

Unlike standard combat, a unit cannot attack separate targets. Instead, during the Weapon Attack Phase, when the controlling player announces he will be making a weapon attack with a unit in an enemy cargo bay, he must choose which of those four targets he will attack. All weapon attacks are made only against that target. In the Physical Attack Phase of the same turn, however, the controlling player can nominate another target; all physical attacks are made only against that target. The following stipulations apply to physical attacks: only punch, kick and physical weapon attacks may be made, and must still adhere to their standard rules (for example, an arm carrying a physical attack weapon cannot deal damage with it if a weapon from that arm is fired in the same turn). Any additional physical weapons effects are lost (a lance will not apply a critical hit, for example).

Regardless of the target of the attack, all weapon attacks are automatically successful; all Cluster Weapons automatically deal their full Damage Value. However, to-hit rolls should still be made to determine jam rolls, possible critical hits against enemy active units and so on. Whether they hit their intended target depends on the target, as noted below.

Finally, for the purposes of these rules, if a friendly unit is already on board the Large Naval Vessel and is in its transport bay (that is, it is not “active” because it has expended MP in a turn following the turn in which it mounted, or hasn't expended MP since the start of the scenario), the controlling player must “activate” units for them to be used, following the *Transport Bay (Expanded)* rules (see p. 217).

### Attacks Against the Interior of a DropShip or Large Naval Vessel

- For each attacking unit, total all damage inflicted by weapon attacks (including rear-firing weapons) that the controlling player makes, and then total all damage inflicted by physical attacks that the controlling player initiates. Randomly determine a hit location on the DropShip or Large Naval Vessel for the total weapon Damage Value and another location



for the total physical attack Damage Value. Apply ten percent (round down) of each total Damage Value to the structural integrity (DropShip) or internal structure (Large Naval Vessel) of the randomly determined locations (which will result in an automatic roll for a possible critical hit for the DropShip, as well as an automatic roll on the Ground Vehicle Critical Hits Table—p. 194, *TW*—for the Large Naval Vessel), and then apply the rest of the damage to the armor in those locations. If the damage exceeds the armor in that location, apply any remaining damage to the internal structure in that location (or half damage, rounded down, to the structural integrity for a DropShip).

- For Large Naval Vessels, compare the damage of both the total weapon Damage Value and total physical attack Damage Value to the vessel's BAR. For every group of damage from the total Damage Value that exceeds the BAR, roll once on the Ground Combat Vehicle Critical Hits Table (see p. 194, *TW*), using the column associated with the location where the damage was applied; these rolls are in addition to the roll made for the damage applied to the internal structure.
- If an area-effect weapon (such as artillery) is used in the bay of a DropShip or Large Naval Vessel, apply all damage equally to all cargo, transport bays and active units. Apply the target hex Damage Value to all cargo (1 point of damage destroys 1 ton of cargo), transport bays (non-active units; use the Front column of the appropriate hit location table) and active units (randomly determine the attack direction and hit location for each 5-point Damage Value grouping), using the standard area-effect rules for artillery damage (see p. 182). In addition, total the Damage Value from such an attack for the target hex, as well as all adjacent hex values (but not any vertical damage), and then divide that equally for the number of locations of the unit (round up). Apply the damage as described above. A unit self-destructing or an engine explosion due to damage (see *Engine Explosions*, p. 77), or a booby trap explosion (see p. 297), are all considered area-effect weapons for purposes of this rule.
- Any ammunition critical hit to the DropShip or Large Naval Vessel that results in an explosion applies damage as an area-effect weapon against all active units.

### Attacks Against Cargo

- All weapon attacks and physical attacks against cargo automatically hit, as noted above. However, for each Damage Value grouping from weapon attacks, the controlling player must roll 2D6. On a result of 10 or more, the attack does not strike the cargo, but instead strikes the DropShip or Large Naval Vessel itself; physical attacks always strike the target cargo and never miss in this fashion.
- First, determine all the attacks that struck the target. For each point of damage, 1 ton of cargo is destroyed; this type of attack against cargo never includes transport bays (unlike a critical hit against cargo, which could damage transport bays; see p. 239, *TW*). The players will need to agree on a set of rules for how this is determined. Regardless of what is destroyed, ammunition (or any weapons that explode) never explodes in this situation. Instead, it is simply destroyed along with whatever else the attack obliterates.

- Next, total all weapon attack Damage Values that missed the target and apply them to the DropShip or Large Naval Vessel exactly as shown under *Attacks Against the Interior of a DropShip or Large Naval Vessel* (see p. 188).

### Attacks Against Transport Bays

- Whenever a player nominates transport bays for his attacks, he has two options: a quick attack or a search. In a quick attack, the player simply nominates "transport bays"; the opposing player randomly determines the specific transport bay that will be the target of those attacks. If the controlling player does not make any weapon or physical attack in a turn, he spends that turn searching. In the following turn, the opposing player must detail the specific units in transport bays and the controlling player can nominate a specific target for the attacks. Once the controlling player has searched and found a target, he can always specifically attack that target. To search for another target, the controlling player must spend another turn searching; that is, not making any weapon or physical attacks.
- All weapon and physical attacks against transport bays automatically hit, as under *Attacks Against the Interior of a DropShip or Large Naval Vessel* (see p. 188). However, for each Damage Value grouping from weapon attacks, the controlling player must roll 2D6. On a result of 8 or more, the attack does not strike the transport bay (i.e. the unit in the transport bay), but instead strikes the DropShip or Large Naval Vessel itself; physical attacks always strike the target unit and never miss in this fashion.
- First, determine all the attacks that struck the target using the Front column of the appropriate hit location table. Determine a different location for each weapon attack, or Damage Value grouping in the case of weapons with multiple groupings.
- Next, total all weapon attack Damage Values that missed the target and apply them to the DropShip or Large Naval Vessel exactly as shown under *Attacks Against the Interior of a DropShip or Large Naval Vessel* (see p. 188).

### Weapon Attacks Against Active Units in Cargo Bays

- If an enemy unit is active (see *Transport Bays (Expanded)*, p. 217), it can be the target of an attack.
- All weapon and physical attacks against an active unit automatically hit, as under *Attacks Against the Interior of a DropShip or Large Naval Vessel* (see p. 188). However, for each Damage Value grouping from weapon attacks, the controlling player must roll 2D6. On a result of 8 or more, the attack does not strike the transport bay, but instead strikes the DropShip or Large Naval Vessel itself; physical attacks always strike the target unit and never miss in this fashion.
- First, determine all the attacks that struck the target; also determine a random attack direction and random location for each Damage Value grouping.
- Next, total all weapon attack Damage Values that missed the target and apply them to the DropShip or Large Naval Vessel exactly as shown under *Attacks Against the Interior of a DropShip or Large Naval Vessel* (see p. 188).
- Infantry units can swarm any enemy units in a cargo bay, using all the standard swarming rules (see *Swarming Attacks*, p. 220, *TW*). Apply a -2 modifier to all swarming attempts.

INTRODUCTION

ADVANCED  
GROUND MOVEMENT

ADVANCED  
COMBAT

ADVANCED  
BUILDINGS

ADVANCED  
SUPPORT  
VEHICLES

GENERAL  
RULES

ADVANCED  
SUPPORT VEHICLE  
CONSTRUCTION

ADVANCED  
WEAPONS  
AND EQUIPMENT

INDEX

RECORD SHEETS



## FIRE DUE TO WEAPON ATTACKS IN CARGO BAYS

Fires in a DropShip or Large Naval Vessel cargo bay are treated differently than fires on the exterior (see p. 44), or in the case of a DropShip where an external fire has no effect. For each weapon attack that strikes the interior of the unit, its cargo or a transport bay, make a roll per the standard rules shown on the Fire Table (see p. 44), applying the standard Fortified Building modifier. If a fire starts, it has a Fire Rating of 1. For Large Naval Vessels, the fire inflicts 1 point of damage to a randomly determined internal structure location each turn during the End Phase (per standard rules, a roll is made on the Ground Vehicle Critical Hits Table, using the appropriate column); for DropShips, damage is halved (rounded down) and applied to the structural integrity, so a Rating 1 fire has no effect (per standard rules, a possible critical hit is still rolled, however).

If multiple fires are started through multiple weapon hits, each additional fire increases the Fire Rating by 1, with each point inflicting a point of internal structure damage to a randomly determined internal structure location. For example, a Fire Rating of 5 would inflict 5 points of damage to 5 randomly determined internal structure locations. For a DropShip, that Fire Rating of 5 would apply 2 points of damage [ $5 / 2 = 2.5$ , rounding down to 2] to the structural integrity.

The controlling player may nominate a platoon (or battle armor squad) of active infantry to fight the fire; an equal number of crew can also be tasked with this job. However, such infantry cannot be involved in a infantry vs. infantry actions (see p. 199); likewise, any crew involved cannot take part in any infantry vs. infantry actions. Crew assigned to fight fires must also be taken into consideration when determining the effective "crew hits" of a unit (see *Crew Casualties Table*, p. 206). The controlling player rolls 2D6; on a result of 8+, the Fire Rating is reduced by 1 point. For each additional active platoon/squad fighting the fire, the controlling player may make a separate roll for each successful attack, or apply a -1 modifier for each additional active platoon/squad to a single roll.

If a friendly active unit mounts a sprayer (see p. 249, *TM*), the controlling player may announce he is fighting the fire. The controlling player rolls 2D6; on a result of 8+, the fire is extinguished, regardless of its rating. For every sprayer that successfully strikes the target in the same Weapon Attack Phase, the controlling player may make a separate roll for each successful attack, or apply a -1 modifier for each additional sprayer to a single roll.



A fire-fight inside a DropShip can be devastating.

At the start of the Movement Phase of Turn 5 of a game, the controlling player of a BNC-5S Banshee (Piloting Skill 4) is standing in a hex adjacent to a water hex occupied by a Luftenburg Supercarrier's aft right hit location (the controlling player of the Supercarrier moved adjacent to land hexes to off-load its complement of 40 vehicles). The level of the underlying terrain occupied by the 'Mech is 2, which is within 2 levels of the surface of the water in the hex occupied by the Supercarrier, and so the Banshee can attempt to board the enemy unit through the bay door in that location.

Per the DropShip mounting rules (see p. 89, *TW*), the controlling player spends half the Banshee's Walking MP and then makes a Piloting Skill Roll with a +4 modifier (the Banshee has not sustained any damage, so no other modifiers are applied). With a result of 9, the player successfully enters the cargo door and is now in the Luftenburg's cargo bay!

Because the vehicles activated (meaning they expended MP) by the Luftenburg's controlling player in Turn 5 have all dismounted, there are no currently active units in the Luftenburg's cargo bay beyond the Banshee. During the Weapon Attack Phase of Turn 5, the Banshee fires all its weapons. All weapons automatically hit with their full Damage Values, resulting in a total Damage Value of 73 [15 (Gauss Rifle) + 20 (2 ER PPCs) + 12 (SRM 6) + 20 (4 medium lasers, including front and rear) + 6 (2 small lasers)]. The controlling player of the Banshee then randomly determines where that damage will be applied. As there are no turrets on the Luftenburg, there are only six locations to choose from, which the players quickly agree are assigned a numerical value of 1 to 6, front to rear; a result of 3 means the damage (as agreed to by the players) is assigned to the Front Right Side. First, the Banshee's player determines 10 percent of 73 and comes up with 7 points [ $73 \times .1 = 7.3$ , rounding down], which is applied to the internal structure. The controlling player of the Luftenburg immediately rolls on the Ground Vehicle Critical Hits Table. The remaining 66 points of damage are assigned to the armor in the Front Right Side. Finally, the players determine how many additional rolls on the Ground Vehicle Critical Hits Table will be required. As the BAR of the Luftenburg is 10, the players divide the total Damage Value by 11, coming up with 6 [ $73 / 11 = 6.6$ , rounding down].

During the Physical Attack Phase of Turn 5, the controlling player of the Banshee makes a kick attack (it cannot punch with either arm, as it made weapon attacks with weapons in both arms), for a total of 19 points. Once again the controlling player of the Banshee randomly determines the location and comes up with the rear. Only 1 point is assigned to the internal structure at that location (causing an automatic roll on the Ground Vehicle Critical Hits Table), while 18 points are assigned to the armor in the rear location. As the 18 points exceeds the Bar of 10 only once, only a single additional roll is made on the Ground Vehicle Critical Hits Table.

At the start of Turn 6, the controlling player of the Luftenburg announces he is activating 4 tanks: 3 Regulators and a Long Tom. During the Movement Phase, the controlling player of the Banshee feels he's doing fine and so decides to stay; the controlling player of the Luftenburg does not dismount those activated units, leaving them to fight the Banshee.

During the Weapon Attack Phase of Turn 6, the Banshee again fires all its weapons at the Luftenburg, with identical results as shown above.



The controlling player of the three Regulators fires their Gauss rifles at the Banshee. The weapons automatically hit, but the controlling player then must roll to see if they hit the Banshee or the Luftenburg. The player rolls a 5, 8 and 9; only one Gauss rifle struck the target! A randomly determined attack direction and hit location will resolve the 15 points of damage against the Banshee. Then a randomly determined location must be assigned to each 15-point Damage Value grouping from the two remaining Gauss rifles; each will inflict 1 point of damage to the internal structure in that randomly determined location, and 14 points against the armor in that location, requiring two rolls each (for a total of four) on the Ground Vehicle Critical Hits Table.

Finally, the controlling player of the Luftenburg turns a little desperate at all the critical hits striking his giant ship and fires a High-Explosive round from the Long Tom. Twenty-five points of damage are inflicted against the Long Tom, the three Regulators and the Banshee (a randomly determined attack direction and hit location made for each 5-point Damage Value grouping). In addition, the attack inflicts 175 points of damage to the Luftenburg [25 (target hex) + 90 (15 points to first adjacent hex times 6) + 60 (5 points to second adjacent hex times 12) = 175]. There are six locations (again, no turrets), so 30 points of damage is applied to each location [175 / 6 = 29.1, rounding up to 30]. As usual, 3 of those points will be assigned to each internal structure location (resulting in six different rolls on the Ground Vehicle Critical Hits Table, one for each appropriate column), while 27 points will be assigned to the armor in each location. Finally, since the BAR of the Luftenburg is 10, the controlling player will make two rolls on the Ground Vehicle Critical Hits Table for each location [30 / 11 = 2.7, rounding down], for a total of twelve additional rolls.

The controlling player of the Luftenburg realizes too late that firing a massive area-effect weapon in the bowels of his own ship probably wasn't a good idea.

## COMMAND-LEVEL (TACTICAL) COMMS

Standard-rules *BattleTech* concentrates on equipment and skills that usually apply on an individual basis. However, some equipment goes well beyond the individual and instead provides a benefit to an entire force within a battlefield operational theater. In addition, the skills of a commander go well beyond piloting and fighting in a 'Mech; they also convey leadership qualities that enable a force to act in ways they would not be able to without that leadership.

The following rules attempt to bring some of the larger aspects of communications and command to the tactical level of play during a scenario.

**Note:** All modifiers, except where specifically noted, are cumulative with all other standard modifiers. Initiative modifiers, in particular, can become very lopsided if both sides do not employ commanders and other Initiative-conveying equipment/units equally.

In addition, depending on the size of forces fielded, both sides may restrict commander assignments. For example, if both sides are fielding a battalion, the players may decide to restrict the nomination of commanders to the company and battalion level, leaving 2 sub-commanders and 1 overall force commander (in place of 8 sub-force commanders and 1 overall force commander if assigning at the lance level).

### COMMANDERS

At the start of a game, before any play takes place, players may nominate sub-force commanders (lances, companies, battalions; Stars, Trinaries, Clusters; Level IIs, Level IIIs, Level IVs; and so on), as well as the overall force commander of each player's force (see *Commanders*, p. 273, *TW*). An overall force commander cannot be a sub-force commander; for example, a company of three lances would have 3 sub-force (lance) commanders and 1 force (company) commander.

Only units piloted by a single warrior may be nominated as a sub-force commander or force commander. The exceptions are the cockpit command console for a BattleMech (see p. 300), infantry (the controlling player nominates which trooper in the squad/platoon is the commander), or any vehicle that uses the Ground Combat Vehicle Critical Hits Table. If the vehicle suffers a Crew Stunned critical hit, the commander is considered to have retreated for purposes of these rules, for as long as the crew is stunned; if the vehicle suffers a Commander Hit critical hit, the commander is considered dead (see below).

Players can hide which commanders are operating which units (or in which infantry unit), though it is advisable to write such information down—each commander on a different piece of paper—and place it hidden on the table so it can be easily confirmed during play as units start to retreat and/or are destroyed.

For each sub-force commander fielded on a side, apply a cumulative +1 Initiative modifier. The force commander can roll twice each turn for Initiative, using the higher roll; the two rolls are made automatically, without reference to any other Initiative rolls made by other players, with the controlling player using the highest value of the two dice rolls (all Initiative modifiers are applied after the two rolls are made and the highest is chosen).

Additionally, each sub-commander and the force commander—at the controlling player's discretion—may be assigned one of the following unique abilities; each ability only applies to the units under that commander's sway. For example, Player A is fielding a company-sized force. Sub-commander One has the Overrun Combat ability, Sub-commander Two has the Disrupt Communications ability, Sub-commander Three has the Zone of Control ability and finally the overall force commander has the Off-Map Movement ability. Only the 4 'Mechs of Sub-commander One's lance may use the Overrun Combat ability, only the 4 'Mechs of Sub-commander Two's lance may use the Disrupt Communications ability and only the 4 'Mechs of Sub-commander Three's lance may use the Zone of Control ability. However, all 12 'Mechs may use the Off-Map Movement ability of the force commander.

If any commander retreats off the playing area, his Initiative modifier is lost, as is his ability; if the controlling player is in the middle of using the ability, he can finish using it (for example, if he is in the middle of off-map movement). If a sub-

INTRODUCTION

ADVANCED  
GROUND MOVEMENT

ADVANCED  
COMBAT

ADVANCED  
BUILDINGS

ADVANCED  
SUPPORT  
VEHICLES

GENERAL  
RULES

ADVANCED  
SUPPORT VEHICLE  
CONSTRUCTION

ADVANCED  
WEAPONS  
AND EQUIPMENT

INDEX

RECORD SHEETS



force commander is killed, not only are his ability and Initiative modifiers lost, but an additional -1 Initiative modifier is applied (a -2 Initiative modifier is applied for the death of the overall force commander).

**Multiple Abilities in a Lance:** If players wish, they can assign multiple sub-commanders in a single lance, effectively also assigning multiple abilities to that lance. However, the player must determine before play begins which sub-commander is the overall leader of a lance; that sub-commander's ability is the only ability that applies during game play. Only if that sub-commander is killed or withdraws from the playing area can the controlling player nominate a new sub-commander to be the overall lance leader, meaning the new sub-commander's ability is in use. The new ability can be used at the start of the turn following the one in which the previous sub-commander was eliminated and/or removed from the playing area.

To maintain the leadership aspect of this style of play, players should avoid simply making every MechWarrior a sub-commander. Instead, players may choose to assigned multiple sub-commanders at the company and battalion (or higher) level, representing XO's (executive officers), whose job is to take over command if a commanding officer should fall during combat.

**Abilities:** The following abilities represent a thin slice of the myriad possibilities that can add extra flavor and cool tactics to a given game. Players are encouraged to draw additional abilities from other *BattleTech* rulebooks and sourcebooks, as well as to generate their own; a scenario played again with the same forces and maps but with commanders having different abilities will offer up new potential fun. However, players should be careful not to create abilities that are too powerful; an ability should be a balanced trade-off between the pros and cons. Ultimately, of course, the players will determine what abilities they wish to use in a game and so can design and field any abilities they wish, so long as all players agree to their use.



*From the command-cockpit of a BattleMaster, a commander orchestrates a desperate defense.*

### **Banking Initiative (Force Commander Only)**

Before making the Initiative roll (both rolls), the controlling player can choose to give the Initiative to his opponent. For each two turns the controlling player elects to lose Initiative in this manner, he may—at a later turn, and before making his Initiative roll—choose to take the Initiative. The controlling player may only “bank” up to two Initiative rolls (giving up four beforehand) at any one time in this way. For purposes of any other special abilities, consider the opponent to have won or lost the Initiative (as appropriate) by a margin of 1.

### **Forcing the Initiative (Force Commander Only)**

The controlling player can “force the initiative” and gain bonuses to his Initiative rolls; the controlling player announces at the start of every turn, before the dice are rolled, whether he will use this ability or not. The bonus is equal to the number of enemy units his side destroyed in the previous turn, reduced by the number of his own destroyed units.

For example, a side with this capability receives a +2 Initiative bonus if it destroyed four enemy units and lost two of its own during the previous turn.

### **Off-Map Movement**

A player may only use this ability if the scenario type allows for it. For example, an offensive force may not use this ability in breakthrough scenarios; in a hold-the-line scenario, the defending force cannot use off-map movement.

To use this ability, the controlling player writes down the exit hex and mapsheet of each unit moving off-map. The player then writes down the hex, mapsheet and turn at which each unit will re-enter. Before re-entering the map, an exiting unit must remain off the map for the amount of time it would take to travel from its exit hex to its entrance hex. To calculate this travel time, count the number of blank half hexes along the map edges between the entrance and exit hexes. Then divide this number by the unit's Running/Flanking MP (rounding fractions up). The result is the minimum number of turns the unit must remain off the map. The controlling player can delay the unit's re-entry beyond this period if he desires, but must select the re-entry turn when the unit leaves the map.

Each returning unit re-enters the map in the End Phase of the turn noted on its “written orders.” At that time, the opposing player can check the unit's orders to make sure the move was legal. If the move was illegal, the unit is considered destroyed and removed from play. (A move is illegal if the unit does not remain off the map for the required travel time or does not enter at the location and turn noted on its written orders.) In a campaign setting, these “destroyed” units may be brought back into play in a later battle, since they are actually lost rather than destroyed.

If a returning unit is supposed to enter the map in a hex containing an enemy unit, or containing a friendly unit that would violate the stacking limits of the hex, the returning unit is placed in a hex of the opposing player's choice adjacent to the intended entry hex.

Once the returning unit has re-entered the map, any enemy unit adjacent to it may immediately attack it using the rules for Point Blank Shots from Hidden Units (see p. 260, *TW*). This attack does not restrict the attacking unit's ability to make attacks in the following turn.

Units off the map cannot engage in combat. If the opposing force destroys all the units remaining on the map before off-map units return, the battle is lost.

**Initiative:** Off-map units do not count toward Initiative.



### Overrun Combat

When rolling Initiative for overrun-capable forces, the controlling player notes the die roll result's Margin of Success (MoS). Divide the MoS by 2 and round fractions down. The result equals the number of individual units that may move, designate their targets and fire before any other units move and fire. "Extra" successes (such as when the player has more successes than there are units available to move) do not carry over to later turns. For example, an overrun-capable force makes an Initiative roll of 11, while its opponent rolls a 6. That gives the overrun-capable force an MoS of 5, allowing two units to move and fire before any opposing units may move (5 divided by 2 is 2.5, rounded down to 2).

Units employing the overrun capability do not take part in the normal move/fire sequence and so do not count when determining how many units each side must move when alternating turns during the Movement and Weapon Attack phases. Overrunning units make physical attacks as normal during the Physical Attack Phase.

### Communications Disruption

Assign numerical values to a number of lances in the opposing force equal to the number of lances controlled by the commander. For example, a lance commander could only assign a numerical value to a single opposing lance, a company commander could assign a numerical value to 3 different opposing lances, a battalion commander could assign a numerical value to 9 different opposing lances, and so on. The specific lances chosen are completely at the discretion of the controlling player.

At the beginning of each turn, the controlling player rolls 1D6. On a result of 6, the player randomly determines the numerical value corresponding to one of the lances in the opposing force; this can be done with a die roll, pulling a number out of a hat, and so on (the players should determine what method to use before the start of the game). That unit may only expend Walking/Cruising/Safe Thrust during the Movement Phase of that turn (this does not affect units only expending Jumping, VTOL or UMU MP).

### Zone of Control (Sub-Force Commander Only)

To create a "zone of control," a unit must enter an adjacent hex to an enemy unit that has not moved yet this turn, and must have at least 1 unused MP remaining at the end of the Movement Phase, and must be directly facing the enemy unit. If these conditions are met, the enemy unit cannot enter either of the two hexes adjacent to its own and the one occupied by the enemy unit exerting the zone of control; this only applies to the current Movement Phase. Additionally, this only applies to "ground movement". A unit expending Jumping or VTOL MPs can enter those hexes, though it cannot end the Movement Phase in those hexes.

**Infantry:** Infantry can only exert a zone of control against another infantry unit.

### Sharp Shooters (Sub-Force Commander Only)

Use the following range modifiers in place of the standard range modifiers: Short +1, Medium +2, Long +3, Extreme +4.

### Brawlers (Sub-Force Commander Only)

Use the following range modifiers in place of the standard range modifiers: Short -1, Medium +2, Long +5, Extreme +10.

### Anti-Aircraft Specialists (Sub-Force Commander Only)

All weapon attacks against airborne units receive a -2 to-hit modifier. Against all ground targets (including grounded aerospace units), apply a +1 to-hit modifier. This ability can only be taken by non-aerospace units; any aerospace units in a force with this ability do not gain its benefits.

### Ground Attack Specialists (Sub-Force Commander Only)

All weapon attacks against non-airborne units receive a -2 to-hit modifier. Against all airborne targets (including airborne ground units, such as VTOLs and WiGEs), apply a +1 to-hit modifier. This ability can only be taken by aerospace units; any non-aerospace units in a force with this ability do not gain its benefits.

### SATELLITES

As discussed under *Satellites* (see p. 148), these units can be placed in low orbit or geo-synchronous orbit. How useful such Satellites are for ground-based battles is dependent on the ability to communicate with them and whether they are actually over the field of battle; a battle may extend beyond the reach of a stationary geo-synchronous orbit, or there may be overlapping low-orbit Satellites that provide a constant benefit as one passes out of range and another enters.

The following rules allow for limited implementation of these all-important (though often rare) resources in a scenario. These rules assume that the players in question are not actively deploying Satellite units in a scenario, but instead require a generalized set of rules for how to use whatever Satellites may be in orbit around a planet. If players are employing Satellites as units, they can feel free to wed these rules to those units, thus allowing aerospace units to attempt to engage and destroy the Satellites and deprive a side of the benefits they provide.

**Note:** Communications technology in the 31st century has progressed dramatically since the 20th century, but military communications jamming and signal corruption technology has possibly advanced even further. Combined with the relative abundance of power available to a fusion-powered unit, the signal interference ability of even a regular communications suite is tremendous. This makes unaugmented long-range communications difficult, sometimes requiring massive communications arrays that draw significant amounts of power to end up with performance that would be considered pathetic 1,000 years ago.

Also note that these rules play fast and loose with realism in an attempt to provide fun and useful in-game benefits that are relatively balanced within the context of a single scenario. In reality, the benefits often provided might require days if not weeks of observation from Satellites to generate a given bonus.

INTRODUCTION

ADVANCED  
GROUND MOVEMENT

ADVANCED  
COMBAT

ADVANCED  
BUILDINGS

ADVANCED  
SUPPORT  
VEHICLES

GENERAL  
RULES

ADVANCED  
SUPPORT VEHICLE  
CONSTRUCTION

ADVANCED  
WEAPONS  
AND EQUIPMENT

INDEX

RECORD SHEETS



### Establishing Uplink

Unless a commander knows exactly the type of Satellites in orbit around the target planet or brings his own (see *Satellite Imagers*, below), he must use the communication equipment at his disposal to attempt to determine what Satellites (if any) are available over the battlefield and whether or not he can access them.

During the End Phase of any turn, the controlling player of a unit with a minimum 4 tons' worth of manned Communication Equipment (see p. 212, *TM*) may roll 2D6 to determine if a Satellite is available. On a result of 8+, there is a low-orbit Satellite that can provide a battlefield benefit. If the roll result is a 12, there is a geosynchronous Satellite that can provide a battlefield benefit for the rest of the scenario. Only one such roll can be made per turn, and only one Satellite can be found per roll.

A player can continue to roll each turn (even if he rolls a 12) to see if additional Satellites are available, though only one Satellite of each type will be available at one time. For example, while a player may gain access to two different military low-orbit Satellites (after the first one passed out of sight), the player cannot roll two military Satellites at once and double the benefits. If the player rolls a type he has already rolled, re-roll. If the player is lucky enough to have access to all types of Satellites at one time, then he cannot roll for another Satellite until one type of Satellite has passed out of sight (meaning the number of turns that the Satellite's abilities are available has expired).

Only one side may be in control of a single Satellite at a time. However, instead of attempting a Satellite uplink, the player can attempt to hack control of the Satellite away from the other player (using a Target Number of 11 or higher, as noted below). Though only a single roll can be made in a turn per side to see if a Satellite is available, a player attempting to hack a Satellite(s) away from a controlling player can make a number of rolls per turn equal to the number of units that mount the required communications equipment, as noted above. If communications with a Satellite are hacked away from another player, the number of turns that the Satellite is available during a scenario remains unchanged. Because all Satellite abilities are direct movement and combat abilities that immediately take effect, the opponent will also immediately know what type of Satellite has been rolled.

If the world is controlled by the faction with which the force is associated (or for whom the mercenary force is working), the player automatically gains the Satellite's benefits; a roll still must be made to see if a Satellite is available, but communication is automatic.

If the world is controlled by a faction not associated with the force (a hostile or neutral faction toward that of the player's force), the player must hack into the Satellite. To do so, the force's controlling player must field a unit with at least 5 tons' worth of manned communication equipment. If the player has such a unit, he rolls 2D6; on a result of 9 or higher (11 or higher if the Satellite is controlled by a hostile faction), the Satellite has been hacked and an uplink established. As noted above under hacking control of a Satellite away from an opposing player, though only a single roll can be made in a turn per side to see if a Satellite is available, a player attempting to hack a Satellite can make a number of rolls per turn equal to the number of units that mount the required communications equipment.

Once communication with a Satellite has been established, the player rolls 1D6 to determine the type of Satellite and its game benefit on the Satellites Type Table (see p. 195); this roll is not made if the player hacks control of a Satellite away from another player (as that Satellite is already determined). Next, the player rolls 1D6 again, with the result being the number of turns that the player gains the benefit (before the Satellite passes out of sight). Benefits begin on the following turn.

These rules assume the players are using the specific advanced rules as noted on the Satellite Type Table. If players are not using a given rule, they can either re-roll for another Satellite that provides benefits that are in use in a given scenario, assume the Satellite is not available and not re-roll, or substitute their own rules that apply to the scenario they are playing.

**Factions:** Using the various fiction sourcebooks published for *Classic BattleTech*, it should be readily apparent which factions are hostile or neutral toward each other. If the players cannot agree, assume the faction is neutral.

**BattleMech Satellite Uplinks:** BattleMechs are equipped with higher-powered communications equipment than other units. A MechWarrior can re-route power in the BattleMech to enhance these communication abilities, but at the price of leaving the BattleMech a sitting target.

During the End Phase of any turn, a player may announce that a BattleMech is attempting a Satellite uplink. The BattleMech cannot take any movement or combat actions (though it can make any Piloting Skill Rolls required by outside actions) in the following turn. For each subsequent turn in which the BattleMech takes no action, it can be used to determine if a Satellite is available, and/or to establish communications with a friendly Satellite; it cannot be used to hack a neutral or hostile Satellite.

**Cockpit Command Console:** A BattleMech mounting a cockpit command console (see p. 300) may determine if a Satellite is available or attempt to establish a Satellite uplink with a friendly or neutral Satellite, but can do so and still move and fire normally in the subsequent turn, provided the second warrior does not need to take any actions to do so. For the turn following the turn in which the player announced that the BattleMech will determine if a Satellite is available, or establish a connection to a friendly or neutral Satellite, the +2 Initiative for the cockpit command console is lost. A cockpit command console cannot be used to hack into a hostile Satellite.

**Pre-Determining Satellites:** In place of randomly rolling Satellites, players can pre-determine the number and type of Satellites that might be available over a given planet, leaving both sides to try to zone in on their availability and establish communication.

### Communications Equipment (Mobile HQs)

Units with massive communications capabilities can provide a commander with a decisive edge during battle. Such units are usually referred to as Mobile HQs.

Any unit that mounts 3 to 6 tons of communications equipment (see p. 212, *TM*) conveys a +1 Initiative modifier to that unit's side. If the unit mounts 7 or more tons of communications equipment, it conveys a +2 Initiative modifier to that unit's side.

In addition to the Initiative modifiers, a Mobile HQ can determine if a generic Satellite is available or attempt to establish communication with a generic Satellite (see *Establishing Uplink*, at



## SATELLITE TYPE TABLE

1D6 Roll	Satellite Type	Benefit
1	Communications	1 unit for every 4 units fielded in a scenario (meaning if there are less than 4 units fielded, this ability has no effect) can increase all its weapons' maximum long range by 1 hex; short- and medium-range brackets (or long-range brackets, if using extreme range) are not affected (representing a comprehensive coordination of overlapping lines of fire).
2	Resource	For any terrain or terrain modification Planetary Conditions (see p. 40) where the outcome of entering a hex is uncertain (magma crust, geyser, breaking through ice, swamp and so on; the PSR for entering a water hex would not count), the player knows what will happen in the hex before entering it (representing long-term ground-penetrating imagery comparisons). If a roll is required after entering a planetary condition hex (to set off the geyser, break through the ice, avoid bogging down in the swamp and so on), the controlling player rolls before entering the hex, and then based on the die roll result can decide to enter the hex, or can change the unit's movement to avoid the hex.
3	Navigation	1 unit for every 4 units fielded in a scenario (meaning if there are less than 4 units fielded, this ability has no effect) can expend 1 additional Running/Flanking/Maximum Thrust MP beyond the unit's limits (representing a unit's ability to find the optimal path through the terrain based on detailed images). Units expending only Jumping, VTOL or UMU MP—meaning they do not select a Cruising/Flanking speed—do not gain this benefit.
4	Military	If the opposing side has hidden minefields, half of those fields (randomly determined; round down) are revealed. This occurs during the End Phase of any turn when communication is established with a new military Satellite. Additionally, for any enemy-controlled command-detonated minefields (including those laid by missile/artillery/bomb munitions), during the End Phase the player may roll 1D6 for each such minefield; on a result of 6, the minefield explodes, dealing its damage as normal.
5	Scientific	The sensors that monitor the various types of energies produced by a planet can be turned into a large-scale ECCM suite (see <i>ECCM</i> , p. 100) or Ghost Target generating suite (see <i>Ghost Targets</i> , p. 101), for the controlling player's side; the controlling player must nominate which effect will be used and it occurs for the duration of the use of that satellite (i.e. you cannot switch between abilities). For an ECCM, a scientific Satellite equals a single ECCM suite, but it covers the entire playing area. For Ghost Target generation, the controlling player must make the standard Piloting Skill Roll at the start of each turn, but at a +4 modifier in place of the standard +2; like the ECCM field, it covers the entire playing area
6	Weather	If weather Planetary Conditions (see p. 57) rules are in use, treat all weather as 1 condition less, to a minimum of the lightest weather condition (representing a crystal-clear image of the ebb and flow of a weather pattern and how a force can use that to its advantage). For example, Heavy Snowfall would become Moderate Snowfall and Moderate Rainfall would become Light Rainfall, but Light Rainfall would still be Light Rainfall.

left) or with a Satellite Imager (see below); if communication is established, those benefits replace the Initiative modifiers provided by the communications equipment for as long as the Satellite benefits are in effect.

If a vehicle acting as a Mobile HQ suffers a stabilizer critical hit (or a 'Mech takes a hip or gyro critical hit), in addition to the normal effects, the Initiative bonus (as well as any benefits from a Satellite/Satellite Imager) only applies if the unit did not expend any MP in the previous turn. If the vehicle suffers a Commander Hit critical hit, the HQ no longer grants the bonus (and loses communication with the Satellite/Satellite Imager, if any existed).

A side may only benefit from one Mobile HQ at a time; this includes a 'Mech mounting a cockpit command console cockpit (see p. 300).

**Large Craft:** For the purposes of these rules only, Large Craft are considered to mount 7 or more tons of communications equipment.

### Satellite Imagers

Satellite Imagers are specific pieces of equipment that provide several different types of abilities as noted in the *Advanced Weapons and Equipment* section (see p. 338). As noted in those rules, a unit must mount at least 4 tons of communications equipment (see p. 212, *TM*) to link with the imager, in which case it automatically conveys the benefits of the imager to that unit's side.

### Electronic Countermeasures

A battlefield can be filled with electronic counter-measures attempting to block communications.

Any unit using equipment (as opposed to the warrior) to communicate in order to provide additional benefits (such as Initiative modifiers), that is located within the bubble effect of an enemy ECM field, loses that bonus; this includes Mobile HQs, the cockpit command console, units communicating with a Satellite and so on. If the unit moves outside the enemy

INTRODUCTION

ADVANCED  
GROUND MOVEMENT

ADVANCED  
COMBAT

ADVANCED  
BUILDINGS

ADVANCED  
SUPPORT  
VEHICLES

GENERAL  
RULES

ADVANCED  
SUPPORT VEHICLE  
CONSTRUCTION

ADVANCED  
WEAPONS  
AND EQUIPMENT

INDEX

RECORD SHEETS



ECM's effect bubble (either through its own movement or due to the movement of the unit carrying the ECM), the benefit is restored—including communication with the Satellite, if it has not yet passed out of sight (that is, the number of turns in which its benefits apply has not expired)—at the start of the turn following the one when the unit clears the ECM bubble.

If using the ECCM rules (see p. 100), a unit is only blocked if the amount of friendly ECCM in a hex is less than the enemy ECM in that hex.

**Communications Equipment:** As described in the ECCM rules (see p. 100), communications equipment can be used to generate an ECCM effect, but doing so makes the equipment lose all its other abilities (the Initiative modifier, determining if a Satellite is available, establishing a Satellite uplink and so on) for as long as it is generating an ECCM effect.

*During a battle, Christian is fielding a force that includes two 'Mechs each mounting a cockpit command console, a grounded DropShip and two Mobile HQs. His House Davion force is raiding a House Kurita world, and so all potential Satellites are considered hostile.*

*During the End Phase of a turn, one of Christian's cockpit command consoles is within the ECM bubble of an enemy unit and so cannot be used to determine if a Satellite is available. His other 'Mech mounting a cockpit command console is not within an ECM bubble. However, because a cockpit command console cannot hack into a hostile Satellite, he decides to not use the remaining 'Mech to determine if a Satellite is available (meaning he'll still gain the +2 Initiative modifier from that 'Mech's cockpit next turn).*

*Instead, Christian uses the DropShip to determine if a Satellite is available and rolls 2D6 (because he's using the DropShip, the +2 Initiative provided by it cannot be used in the following turn). The result is a 9, meaning a Satellite is available. It is a hostile Satellite, unfortunately (House Kurita to his House Davion), so he must attempt to hack in. He immediately rolls 2D6, but the result of 7 means the hacking failed. He can still attempt two more hacks for both Mobile HQs, however, and so nominates an HQ to attempt to hack the Satellite (once*

*again, the +2 Initiative modifier from that Mobile HQ cannot be used in the following turn). He rolls 2D6 and scores an 11! He's hacked the Satellite. He then rolls 1D6 with a result of 4 and consults the Satellite Type Table. However, the players are not using minefields and so they determine he can re-roll (they determined this before play began). This time he rolls a 5, meaning he's established communication with a scientific Satellite; he's more than happy with that result, as the ECCM field will help combat all the ECM fielded by his opponent (as well as helping to disrupt the Satellite communications already established by the opponent). To wrap up this Satellite uplink, he rolls 1D6 with a result of 3, meaning the ECCM effect will last for three turns (provided communication is not interrupted or the opposing player does not hack away communication with the Satellite), starting on the following turn.*

*Finally, even though Christian cannot determine if another Satellite is available, he has 1 remaining HQ. As they're using weather Planetary Conditions and the opposing player was lucky enough to establish communication with a weather Satellite last turn—he rolled a 6, meaning Christian's opponent will gain those benefits for 5 more turns—Christian decides that because his attempts at getting an ECM into place to disrupt that communication have failed, he'll attempt a hack (he's got enough Initiative modifiers from still active commanders—as well as the cockpit command console not in an ECM bubble—to risk the loss of the +2 Initiative modifier from this Mobile HQ in the following turn). He rolls 2D6 with a result of 12!!! He's hacked his opponent's communications from the weather Satellite; he will gain the benefits of that Satellite starting in the following turn, for 5 more turns (provided communication is not interrupted or the opposing player does not hack back communication with the Satellite).*

## EJECTION AND ABANDONING UNITS

The following rules allow for the ejecting from and/or abandoning of units during game play.

**Electronics:** All electronics on a unit where the pilot/crew have ejected or have abandoned the unit continue to function until the unit is destroyed (or captured; see *Taking Control of a Unit*, p. 216).

**ProtoMechs:** ProtoMechs have no ejection system and no way to exit the unit during combat.

### 'MECHS

Under certain unfortunate conditions, a MechWarrior may be forced to leave his BattleMech in a hurry by using the cockpit ejection system. When the pilot fires this system, explosive bolts allow the cockpit canopy to separate from the unit and the pilot rockets away from the now-disabled BattleMech. The ejecting MechWarrior lands in the hex immediately behind the abandoned BattleMech. All BattleMechs are equipped with sensors that detect impending ammo explosions and automatically eject the pilot before the ammo explodes. Because the advent of CASE made it more likely for a BattleMech to survive an ammo explosion, many MechWarriors disable the auto-eject feature. Players must decide before each battle and note on the record sheet whether or not the pilot disables his 'Mech's auto-eject.



A Daboku pilot ejects after a critical hit by a Cyclops



During the Movement Phase, a player may choose to have the MechWarrior eject rather than move. If the auto-eject function is operational, the pilot will automatically eject at the end of any Phase in which an ammo explosion takes place (the pilot still receives the automatic 2 Damage Points for the ammo explosion; see *Ammunition*, p. 125, *TW*). Ejecting from a 'Mech can be dangerous, and the pilot may suffer damage upon landing. The pilot must make a successful Piloting Skill Roll to avoid taking damage, modified for the circumstances listed on the Ejection Modifiers Table.

A pilot who fails this Piloting Skill Roll takes damage equal to the MoF divided by 2 (rounded down), and will need to make a Consciousness Roll for every point of damage taken per the standard rules (see *Consciousness Rolls*, p. 41, *TW*).

A conscious pilot who successfully ejects may move at the rate of 1 MP per turn in the same manner as a standard infantry unit. He may be fired on in the same manner as an infantry unit, but with an additional +2 to-hit modifier. If the pilot ends a Movement Phase in the same hex as any unit (friendly or enemy), the pilot is considered to have been picked up

in the End Phase; he may choose by which unit if more than one occupies the hex. Pilots picked up by friendly units that survive the battle or move off the board have survived and can be used again in future games. Players may ransom pilots captured by enemy forces if they wish.

**Destruction of Head Location:** If players are looking for a slightly less deadly style of play involving MechWarriors—specifically if they are playing a campaign—use the following rule. Any time the internal structure of a cockpit location is destroyed and the unit has an ejection system (not counting a *BattleMech Full-Head Ejection System*, see p. 310), the auto-eject automatically engages. However, regardless of the condition of the pilot, the MechWarrior automatically receives damage to bring its condition up to 5 hits (so a pilot with no hits and a pilot with 3 hits under these rules would both fill out their condition monitors to 5 hits, to represent the MechWarrior's "skin-of-the-teeth" survival). The pilot may still take damage during the ejection itself, and these rules do not apply in the event of a critical hit to a cockpit slot (in which case the pilot is still killed).

**BattleMech Full-Head Ejection System:** This type of ejection involves the removal of the entire 'Mech's head and follows its own set of rules (see p. 310). If the head itself is destroyed (as described above), this form of ejection system will not save the MechWarrior.

**Water:** A MechWarrior cannot eject if the cockpit is submerged (unless it is a full-head eject system; see above).

## VEHICLES

Vehicles do not have an automatic ejection system like BattleMechs (see *Combat Vehicle Escape Pod*, p. 309, for the exception). However, during the End Phase of any turn, a player may announce that the crew of a vehicle is abandoning it. The unit may not take any action during the subsequent turn. During the End Phase of that turn, the crew (however large; see *Vehicle Crews*, p. 218) is treated as an infantry foot platoon (ballistic rifle), with a number of troopers in the platoon equal to the size of the crew. The crew (now platoon) is placed in the same hex (if stacking limits allow) or an adjacent legal hex; if the crew cannot enter a legal hex, they cannot abandon the vehicle. Starting in the turn after they abandon their vehicle, the crew can move and make attacks exactly like a foot infantry platoon for the remainder of the scenario.

Infantry may abandon an airborne vehicle in this same fashion, in which case the vehicle immediately crashes in the hex it occupies. The infantry must use the *Dropping Troops* rules (which are covered in *Strategic Operations*) to resolve where they land, after which they are treated as above.

## NAVAL VESSELS

In the Movement Phase, some or all of a Naval Vessel's crew may be ordered to abandon ship. When abandoning ship, make a Piloting Skill Roll for the unit. A success indicates 1 + MoS lifeboats may launch safely (1 on an MoS of 0, 3 on an MoS of 2, and so on). Additional lifeboats may launch in the same turn, but each must make a Piloting Skill Roll with a +2 modifier, suffering a point of damage for each point of the MoF.

## EJECTION MODIFIERS TABLE

Landing Terrain	Modifier
Clear	-2
Water	-1
Snow	-1
Deep Snow	-2
Rough	0
Rubble	0
Light Jungle/Woods/Ultra Rough	+2
Heavy Jungle/Woods/Ultra Rubble	+3
Ultra Jungle/Woods	+4
Per Level of Building	+1

Planetary Conditions	Modifier
Zero-G	+3
Low-G (more than .2 off Terran standard)	+2
High-G (more than .2 off Terran standard)	+3
Vacuum or Tainted Atmosphere*	+3
Trace or Very High Pressure Atmosphere	+2
Heavy Snow Fall/Ice Storm/Lightning Storm/ Strong Gale/Torrential Downpour	+2
Blizzard/Storm/Tornado	+3

Situation	Modifier
BattleMech Prone	+5
Pilot Unconscious	+3
Per Point of Head Internal Structure Damage	+1
Automatic Ejection	+1

\*Assumes the pilot is wearing a suit to protect against vacuum or a tainted atmosphere; the pilot is killed immediately if in vacuum with no protection (see p. 56 for rules governing a tainted atmosphere and no protection).

INTRODUCTION

ADVANCED  
GROUND MOVEMENT

ADVANCED  
COMBAT

ADVANCED  
BUILDINGS

ADVANCED  
SUPPORT  
VEHICLES

GENERAL  
RULES

ADVANCED  
SUPPORT VEHICLE  
CONSTRUCTION

ADVANCED  
WEAPONS  
AND EQUIPMENT

INDEX

RECORD SHEETS



When crewmen abandon a naval vessel, lifeboats are placed in adjacent water hexes. These lifeboats count as a conventional infantry unit for purposes of stacking, and for attacks against them. Each lifeboat has a damage capacity equal to 1 point (for the boat) plus 1 “trooper” per crewman on board (to a maximum of 10 troopers per boat). Lifeboats have 1 MP on water hexes only.

If a crew abandons a submerged vessel, the lifeboat is placed as above, but at the depth level of the ship; the lifeboat will then rise 1 depth at the end of the Movement Phase each turn until it reaches the surface, before moving as noted above.

Individual crewmen can also abandon ship (using life vests and/or breathing gear, as necessary), but may do so only from a surface vessel or a submerged vessel at a Depth of 15 or less. Crewmen who abandon ship in this manner receive 0 MP, and will simply float on the water surface, subject to Water Flow rules if those are in play (see p. 52).

Another naval vessel (or a hover vehicle; or non-naval vehicle with the Amphibious Chassis and Controls modification; or a WiGE Vehicle that lands on the water’s surface) may rescue crew from any lifeboats if it ends its turn in a lifeboat’s hex (or adjacent to it, if the rescuing unit is a Large-size Naval Vessel), and then takes no other actions for the subsequent turn. During the End Phase of that subsequent turn, the crew from the lifeboat is rescued and now considered to be on board the rescuing vessel. If the rescuing unit moves out of the hex before the End Phase for any reason, the rescue operation fails, but can be attempted again any number of times, as long as the criteria above are met.

VTOLs and Airships may also attempt to rescue a lifeboat or individual crewmen without landing on the surface of the water. These units must end their turn in the hex occupied by the lifeboat or individual crewmen and must be at Elevation 1, or Altitude 1 (NOE) in the case of an Airship; for a Large Airship, the pivot point hex must be in the hex occupied by the lifeboat. Over the next two subsequent turns, the rescuing unit cannot take any other action (except to spend MP to stay in the hex). At the end of that time, the crew from the lifeboat is rescued. As with a naval rescue, if the rescuing unit moves out of the hex (or to a higher elevation) for any reason before the rescue operation is completed, the operation fails, but can be attempted again in a following turn.

Only one lifeboat (or 10 individual crewmen) may be rescued per turn in either case (if the rescuing unit is a multi-hex unit, such as a Large Naval Vessel, it can rescue one lifeboat—or 10 crewmen—per hex that touches water and is adjacent to a lifeboat, per the above criteria). A rescuing unit must also have enough cargo space to accommodate an equivalent number of conventional foot infantry for the rescued crewmen, assessed at 0.1 tons per crewman. So if a vessel picks up ten full lifeboats, it must have the cargo capacity to carry a 100-man conventional foot infantry platoon [10 lifeboats x 10 crewmen each = 100] or 10 tons of cargo space [100 x 0.1 = 10].

## FATIGUE

A standard *BattleTech* game turn lasts only 10 seconds, meaning that even a battle of 20 to 30 turns is only five minutes long. As such, Standard Rules play generally ignores fatigue. However, combat is exceptionally draining, emotionally and physically; seconds can seem like minutes, and five minutes can feel like hours. Use the following rules to introduce the concept of battle fatigue directly into a *BattleTech* game.

A unit’s ability to ignore fatigue is based on its rating (as determined by the Piloting Skill Rating), as shown on the Fatigue Table. When a unit reaches the start of its target turn, apply a +1 Piloting Skill Roll for the remainder of the scenario. In addition, when a unit reaches the next level’s starting point, also apply a +1 to-hit modifier to all attacks. For example, at the start of Turn 10, all Green units would apply a +1 Piloting Skill Roll modifier. Then, at the start of Turn 14, all Regular units would also apply a +1 Piloting Skill Roll modifier, while the Green units would add a +1 to-hit modifier to all attacks. Note that this means Elite pilots never apply a to-hit modifier.

**Conventional Infantry:** In addition to the restriction above, Foot Conventional Infantry, once they are fatigued, can either move, or they can make a weapon attack, or they can make an anti-Mech attack in a turn; i.e. in a turn a fatigued Foot Conventional Infantry may take only 1 of those three actions. If a fatigued Foot Conventional Infantry unit takes no actions in a turn (does not expend MPs or make any type of attack), then in the following turn it may move and make attacks normally; this is not cumulative, so that if a unit takes no actions for two turns, it would still only be able to move and attack normally on the following turn, but on the turn after that the unit would be back to a single action per turn restriction.

### FATIGUE TABLE

Piloting Skill Rating	Turn When Modifier Starts
6–7	Starting on Turn 10
4–5	Starting on Turn 14
2–3	Starting on Turn 17
0–1	Starting on Turn 20

## IMPROVED POSITIONS

Given enough time, a defending unit can improve the natural defenses of the surrounding terrain. If both sides agree to use the improved positions rule, units that start on the mapsheet may begin the game in improved positions. Treat these field fortifications as a Light Standard Building with a CF of 15 (damage is assigned to them exactly like building hexes, including collapsing and so on). These positions do not affect LOS or movement, and a unit cannot climb on top of an improved position to increase its level. Apply standard terrain modifiers to any unit in an improved position. Units that begin the game in improved positions may also use the Hidden Units rule (see p. 259, *TW*).



Improved positions can be used by any player; if the controlling player moves units out of an improved position, an opponent can move into those same improved positions and gain their benefits. Improved positions cannot be used to make units hidden during a scenario, however.

## INFANTRY VS. INFANTRY ACTIONS

The infantry vs. infantry actions rules allow for the large-scale resolution of infantry-only combat. While this system can be used in almost any situation the players desire, because it is a wholly separate combat—with infantry literally removed from standard *BattleTech* combat while these rules are in play—it is best used in situations where normally only infantry will fight infantry: in buildings, or during boarding actions involving Large Naval Vessels or Small and Large Craft.

Regardless of the location, the basics of infantry vs. infantry actions remain the same. The following rules provide those basics, as well as touching on the unique rules that also apply to combat within buildings, Large Naval Vessels and aerospace units.

### BOARDING ACTIONS (INFANTRY)

Boarding an enemy unit (whether a large traditional wet-navy vessel or an aerospace unit) is a tactic as old as naval warfare. The rules specifically refer to the use of infantry to board an enemy unit, move into the bowels of the vessel and fight the defenders for control of the ship; other units boarding an enemy unit for an attack inside a vessel are dealt with under *Boarding Actions (Non-Infantry)* (see p. 188). The basics of such actions are the same, regardless of which unit type is being boarded. The specifics unique to each type of unit are described in detail, as appropriate.

**Legal Targets:** Only Large Naval Vessel Support Vehicles, Small Craft and Large Craft may be boarded using these rules. Players can choose to either use these rules, or the *Combat Within Buildings* rules (see p. 175, *TW*) when resolving infantry actions inside a Mobile Structure.

### Docking and Grappling Aerospace Units

Before an infantry vs. infantry action can occur aboard an aerospace unit, an opponent must either dock or grapple with the target unit.

A Large Craft can only dock with a target unit for a boarding action if that target unit cannot expend any thrust points in the turn the docking maneuver is attempted (meaning it has taken damage that disallows thrust expenditure). The Large Craft must end the Movement Phase in the same hex as its target and match velocity and heading with the defending unit. At the end of the Movement Phase (Aerospace), a Large Craft that has matched velocity and heading with a defending unit may attempt to dock with a target that cannot expend thrust. Roll 2D6 to determine the success of the docking attempt against a Target Number of 8. Apply a cumulative -2 modifier for each turn in which the attacker matches the de-

fender's velocity and heading; if during any subsequent turn the defender expends thrust, not only can the attacker no longer dock, but the cumulative count modifier is lost.

Any Small Craft may operate as an assault craft to dock with a target, regardless of whether or not it can expend thrust points. Each ton of cargo space on a Small Craft can hold five marines in space suits or one marine (or Elemental) in battle armor. Apply a +2 modifier to any target numbers for attacks against such Small Craft, to reflect the erratic maneuvers such units make to avoid enemy fire during the approach. To grapple a target unit for a boarding action, the Small Craft must end the Movement Phase in the same hex as its target and match velocity and heading with the defending unit. At the end of the Movement Phase (Aerospace), a Small Craft that has matched velocity and heading with a defending unit may attempt to grapple the target. Roll 2D6 to determine the success of grappling, against a Target Number of 8. A successful roll attaches a grapple to the target ship and allows the Small Craft to deploy forces to board it.

In both instances, if a docking/grappling maneuver is successful, both the attacking and defending players should roll 1D6 to randomly determine the location on both aerospace units where the docking/grappling occurred: 1 Nose; 2 Left-Front/Left-Wing; 3 Right-Front/Right-Wing; 4 Left-Aft/Left-Wing Aft; 5 Right-Aft/Right-Wing Aft; and 6 Aft. This roll applies regardless of the defending unit type; docking never occurs on the "broad side" of a WarShip, as captains are never suicidal enough to try to maneuver themselves in front of that many guns.

In the End Phase of any space turn during a boarding action, the player who controls the attacking aerospace unit can announce that the unit will disconnect from the dock/grapple, leaving the marine boarding action to continue. No roll is required, and the attacking unit is once again counted for Initiative (see *Initiative*, below) at the start of the following turn and can maneuver normally.

**Attacks From Attacking and Defending Aerospace Units:** Neither the defending nor attacking aerospace unit can make any attacks using weapons in the arc where the docking/grappling occurred (as determined by the random die roll noted above). The only exceptions are when different unit classifications are involved; for example, Small Craft to DropShips. If a smaller-class unit is docked/grappled to a unit with a larger classification, the smaller unit still cannot use the weapons in the arc where the docking/grappling occurred, but the larger unit can use weapons in its arc; this applies regardless of whether the smaller or larger unit is the defender or attacker. For example, a Small Craft grappled to a DropShip on its aft could not use any aft weapons, but the defending unit can still fire its weapons in the Fore-Front Arc.

**Attacking a Docked/Grappled Unit:** The ability to attack a defending or attacking aerospace unit in a boarding action depends on the unit classification, as discussed above under *Attacks From Attacking and Defending Aerospace Units*.

Attacks against a target aerospace unit in a smaller classification than another docked/grappled aerospace unit, in which the attack direction corresponds to the location where the larger aerospace unit is attached, cannot be made. For example, an aerospace unit is attempting to attack a Small Craft grappled to a DropShip. The DropShip is attached to the Small

INTRODUCTION

ADVANCED  
GROUND MOVEMENT

ADVANCED  
COMBAT

ADVANCED  
BUILDINGS

ADVANCED  
SUPPORT  
VEHICLES

GENERAL  
RULES

ADVANCED  
SUPPORT VEHICLE  
CONSTRUCTION

ADVANCED  
WEAPONS  
AND EQUIPMENT

INDEX

RECORD SHEETS



Craft's aft location, and the line of sight from the attacker to the target Small Craft falls into the aft location. This attack cannot be made because LOS is blocked by the DropShip. In the case of an Above/Below situation (see p. 238, *TW*), an attack can be made, but once a successful weapon attack occurs, the attacking player must roll 1D6. On a result of 1–3, the attack strikes the intended target; on a result of 4–6, the attack strikes the other aerospace unit. In a situation where multiple aerospace units are docked to a target, randomly determine which other aerospace unit is struck.

Attacks against a target aerospace unit in a larger unit classification than another docked/grappled aerospace unit can be made. If the location of the successful attack corresponds to the location where another aerospace unit is docked/grappled, the attack has a chance of striking the other aerospace unit. The attacking player rolls 1D6. If the aerospace unit in question is a single classification smaller (a Small Craft grappled to a DropShip), on a result of 5–6 the attack strikes that other aerospace unit; on a result of 1–4, it strikes the intended target.

In all such instances, make sure to take into account the orientation of the other aerospace unit that is struck, to best determine where the attack lands. Players may need to randomly roll to determine the hit location, as it may not be clear-cut.

**Expending Thrust:** An attacking aerospace unit that is docked/grappled cannot expend thrust, as doing so will automatically break the dock/grapple; the attacking aerospace unit would need to match velocity and heading during the Movement Phase (Aerospace) of a subsequent turn and attempt a new dock/grapple maneuver. If the defending aerospace unit changes velocity, the attacking player must make a standard grapple/docking roll at the end of the Movement Phase (Aerospace) in which that change occurred; apply a +1 modifier for every 2 points of velocity change.

**Initiative:** Aerospace units that are docked or grappled for a boarding action do not count toward Initiative. If the aerospace unit breaks away from the dock/grapple for any reason, it counts toward Initiative in the following turn.

**Multiple Docking/Grapping:** A Small Craft can only be docked/grappled by a single unit at one time; this means that if two Small Craft are docked/grappled, then no other aerospace units can attempt to dock/grapple with either unit. A DropShip can only be docked/grappled by two units at one time, but not in the same arc; re-roll the random arc location for the defending unit if that location is already occupied by another unit. In all instances, if an attacking unit breaks the dock/grapple, a new attacking unit can attempt to dock/grapple in a subsequent turn.

### Grapping Large Naval Vessels

Similar to aerospace units attempting to grapple a target in the depths of space, any Small or Medium Combat/Support Naval Vessel, any type of Hover Vehicle, VTOL Vehicle or any type of Airship may attempt to grapple an enemy Large Naval Vessel Support Vehicle.

To grapple a target unit for a boarding action, the vehicle in question must end the Movement Phase in a hex adjacent to a hex occupied by the target (this cannot be at its front or rear), with the same orientation; in the case of Airships, this can either be an adjacent hex or a hex occupied by the target vessel, but the Airship must be at Altitude 1 (NOE); for VTOLs, if the unit occupies the same hex, it must be at least 1 elevation above the top level (deck) of the target unit. At the end of the Movement Phase (Ground), a vehicle in a hex adjacent to the target may attempt to

grapple it. Roll 2D6 to determine the success of grappling, against a Target Number 6 (if the target unit is completely submerged, the Target Number is 8). A successful roll attaches a grapple to the target ship and allows the grappling vehicle to deploy forces to board it; all infantry units (as well as all other ship crew/personnel) currently carried by the attacking vessel can be used in the boarding action (except for mechanized infantry). All actions occur during the time frame of a ground turn, as opposed to a space turn. If the grappling roll fails, the vehicle can attempt the grapple again at the end of the following turn's Movement Phase, provided it is still adjacent to the target vessel.

When grappling a target vessel, use the Large Naval Template (see the record sheets at the back of the book) to determine where on the unit the grappling occurred (in the case of Airships above the target vessel, neither unit blocks any arcs); in all cases, the attacking vessel will have the same orientation as the target vessel. Neither the defending nor attacking units can make any attacks using weapons in the same arc where the grappling occurred (this applies to Airships as well).

**Infantry Grapping:** As opposed to an infantry-carrying vehicle grappling a Large Naval Vessel in order to deploy infantry troops (as noted above), infantry units alone can attempt to board and seize control of an enemy Large Naval Vessel Support Vehicle. Mechanized infantry (except VTOL mechanized infantry) cannot be involved in such an action.

Infantry units without Jumping, VTOL or UMU MP cannot board a target Large Naval Vessel Support Vehicle unless it is in an adjacent hex to the one occupied by the infantry unit at the start of the infantry's Ground Movement Phase (this can include a land hex occupied by an infantry unit, or by another Large Naval Vessel Support Vehicle where the infantry is on the deck (as opposed to being carried using the Infantry Carriers rules, p. 223, *TW*).

Infantry units with Jumping or VTOL MP can mount a target naval vessel provided they can move the required number of hexes to the target, within the number of MP they have available (all standard Jumping and VTOL movement rules apply; see pp. 53–54, *TW*).

Infantry units with UMU MP can mount a target naval vessel, provided they are at the same depth (any depth corresponding to one of the depths occupied by the target unit in the case of a unit that occupies more than 1 depth simultaneously) and in the same hex as the naval vessel (either submerged or on the surface) at the start of their Ground Movement Phase.

In all instances of infantry attempting to board the target vessel, the unit must make an Anti-Mech Skill Roll (apply a +2 modifier if the target unit is submerged). A successful roll allows the infantry to board the vessel; a failure means the attempt did not succeed, and the infantry unit remains in the hex at the level/depth/elevation from which it attempted to board. In the case of infantry using UMU MP to board a target vessel, on a failed attempt, apply a single point of damage to all battle armored troopers, or in the case of conventional infantry, apply a single 5-point Damage Value grouping as though another infantry unit had made a successful attack.

Once an infantry unit has successfully boarded the vessel, at the controlling player's discretion it can either remain "on deck" and move and fight using standard movement and combat (see *Specialized Attacks*, p. 157), or it can actually move into the bowels of the vessel to attempt to take control. In the latter case, the infantry are removed from the playing area and an infantry vs. infantry action takes place.



### Grappling Mobile Structures

Use the following rules to grapple Mobile Structures; once a grapple has occurred, an infantry vs. infantry action is treated as conflict inside a building. All actions occur during the time frame of a ground turn, as opposed to a space turn.

**Water:** For Water Mobile Structures, use all the rules that apply to Large Naval Vessels.

**Ground:** Any vehicle in an adjacent hex to a Ground Mobile Structure may attempt a grapple. To grapple a target unit for a boarding action, the vehicle in question must end the Movement Phase in a hex adjacent to a hex occupied by the target (the orientation does not matter); in the case of Airships, this can either be an adjacent hex or a hex occupied by the target vessel, but the Airship must be at Altitude 1 (NOE). At the end of the Movement Phase (Ground), a vehicle in a hex adjacent to the target may attempt to grapple it. Roll 2D6 to determine the success of grappling, against a Target Number 4. A successful roll attaches a grapple to the target ship and allows the grappling vehicle to deploy forces to board it; all infantry units (as well as all other ship crew/personnel) currently carried by the attacking vessel can be used in the boarding action (except for mechanized infantry). If the grappling roll fails, the vehicle can attempt the grapple again at the end of the following turn's Movement Phase, provided it is still adjacent to the target vessel.

**Air:** Any Air Mobile Structure or Airship can attempt to grapple an Air Mobile Structure; if the Air Mobile Structure is at Altitude 1 (NOE), an airborne VTOL (regardless of elevation) may attempt to grapple as well. To grapple a target unit for a boarding action, the unit in question must end the Movement Phase in the same hex and at the same altitude as the target unit. At the end of the Movement Phase (Ground), a vehicle in a hex adjacent to the target may attempt to grapple it. Roll 2D6 to determine the success of grappling, against a Target Number 8. A successful roll attaches a grapple to the target ship and allows the grappling vehicle to deploy forces to board it; all infantry units (as well as all other ship crew/personnel) currently carried by the attacking vessel can be used in the boarding action (except for mechanized infantry). If the grappling roll fails, the vehicle can attempt the grapple again at the end of the following turn's Movement Phase, provided it is still adjacent to the target unit.

**Infantry Grappling:** All the rules for infantry grappling of a Large Naval Vessel also apply, as appropriate, to Mobile Structures.

### INFANTRY VS. INFANTRY ACTION INSIDE A BUILDING

Unlike Large Naval Vessels and aerospace units, which require an opponent to board the unit—which can be difficult—before an infantry vs. infantry action can take place, combat inside any type of building can take place as soon as an infantry unit enters a building hex (see *Castles Brians*, p. 141, for the exception).

Note that such infantry vs. infantry action only occurs with those infantry (and other personnel, as described under *Resolving Infantry Vs. Infantry Actions*, below) occupying the same multi-hex building. Even if infantry on either player's side are in adjacent building hexes, if the building hexes are not a part of the multi-hex building being fought over, they cannot be used until those units are moved into the same multi-hex building and added to a future turn's Marine Points Score.

### RESOLVING INFANTRY VS. INFANTRY ACTIONS

Use the following rules to resolve an infantry vs. infantry combat situation.

**Marines:** These rules use the term "marine" as a generic word to describe a single trooper, the baseline from which all other personnel are valued (whether a conventional infantryman for a ground-based action, or an infantryman trained in zero-g operations for actions on board Small and Large Craft in space).

#### Marine Points Score

To determine the result of an infantry vs. infantry action, first establish the total number of combatants fielded by each side; how many marines (or other combatants) are added to each side is up to the controlling player (for example, a controlling player can hold some marines in reserve). Adding up the Marine Points for the relevant troop types as shown on the Marine Points Table below will generate a final Marine Points Score for each unit.

In the case of battle armor, the player first determines whether the trooper is a Clan Elemental or an Inner Sphere-trained warrior, and then adds the appropriate modifier based on the type of battle armor, as well as any additional equipment modifiers.

Most unit record sheets (or Technical Readout write-ups) indicate the number of marines, non-marines (military personnel not specifically trained for combat in micro-gravity), civilians and so on. If it is at all ambiguous, the players must agree to the exact personnel allotment before a boarding action can begin.

**Crew:** When an infantry vs. infantry action occurs where crew may get involved (for example, on a target unit, a Mobile Structure, or a building mounting weaponry and so possessing "crew"), the crewmen must be taken into consideration for the Marine Points Score.

Neither the attacker's nor the defender's crew (if both sides have such crews available) are automatically tallied into the Marine Points Score. Instead, each player must decide how much of each unit's crew (including a building crew, if any) will be committed to the attack for each turn that an infantry vs. infantry action roll is made. The more crew committed to the attack, the more the unit's performance degrades. Use the Crew Casualties Table (see p. 206) to determine the exact effects; each crewmember hit imposes a +1 to-hit modifier for any attacks made by that unit, as well as a +1 modifier for any Piloting Skill Rolls/Control Rolls, for the duration of the time that those crew are committed to the infantry vs. infantry action.

As shown under the *Crew Losses and Crew Hits* rules (see p. 206), these values can last for the rest of the game if a unit's crew sustained heavy damage, whether or not the infantry vs. infantry action is successful. While this may be preferable to losing the unit/building, such things must be taken into consideration as a player determines how much of a crew to throw into the battle.

During each turn's infantry vs. infantry action roll (see p. 204), both players can add more crew at their discretion; doing so, however, requires re-determining either side's Marine Points Score. Neither player need reveal how many additional crew (or bay personnel or civilians, as noted below) are being added

INTRODUCTION

ADVANCED  
GROUND MOVEMENT

ADVANCED  
COMBAT

ADVANCED  
BUILDINGS

ADVANCED  
SUPPORT  
VEHICLES

GENERAL  
RULES

ADVANCED  
SUPPORT VEHICLE  
CONSTRUCTION

ADVANCED  
WEAPONS  
AND EQUIPMENT

INDEX

RECORD SHEETS



## MARINE POINTS TABLES

Trooper Type	Marine Point Values (each)
Clan Battle Armor Weight Class	
Elemental trooper without armor	2
PA(L)	+0
Light/Medium	+1
Heavy	+2
Assault	+3
Inner Sphere Battle Armor Weight Class	
Inner Sphere battle armor trooper without armor	1
PA(L)	+0
Light/Medium	+1
Heavy	+2
Assault	+3
Marine	1
Any Marine wearing armor with a 2 or more Damage Divisor*	2
Non-combat unit crew/fighter pilot	0.25
Non-marine soldiers (MechWarriors/vehicles/infantry)	0.5
Other (civilians)	0.1

\*See *Infantry Armor*, p. 317. Even if a Clan Elemental wears such armor, the Marine Point Value is never more than 2 per trooper.

Battle Armor Modifiers	Marine Point Values (per trooper)
Quad	-1 (only applied in microgravity)
Mounts any Burst-Fire Weapons*	+1
Mounts space operations adaptation	+1
Mounts claws and/or magnets	+1
Mounts vibro-claws	+1
Mounts cutting torch	+0.25
Mounts industrial drill	+0.25

to the Marine Points Score until the roll is made. Both players should write down the number of crew used and the equivalent Marine Points Scores they provide, and then reveal them simultaneously; this helps to convey the dangers and confusion inherent in infantry vs. infantry actions.

Finally, if a unit has already taken a crew critical hit, that hit represents crew eliminated and must be taken into consideration. Use the Crew Casualties Table (see p. 206) to determine what percentage of the crew has been eliminated, and what percentage remains viable for use in any infantry vs. infantry actions.

**Bay Personnel:** The term "bay personnel" (as shown on record sheets and in Technical Readout write-ups for various units) includes aerospace pilots, MechWarriors and so on, along with their technicians. If a building mounts a transport bay, it also will have

## BAY PERSONNEL TABLE

Bay Type	Units Carried	Unit	
		Personnel	Technicians
'Mech	1 'Mech	1	1
ProtoMech Point	5 ProtoMechs	5	1
Light Vehicle*	1 Light Vehicle	4	1
Heavy Vehicle†	1 Heavy Vehicle	7	1
Super-Heavy Vehicles‡	1 Super-Heavy	10	1
Fighter	1 fighter	1	1
Small Craft	1 Small Craft	4	1
Battle armor Squad (IS)	4 troopers	4	2
Battle Armor Point (Clan)	5 troopers	5	1
Battle Armor Squad (CS/WoB)	6 troopers	6	2
Mechanized Infantry Squad§	5 troopers	5	1
Infantry Platoon (Foot)	28 troopers	28	0
Infantry Platoon (Jump)	21 troopers	21	0
Infantry Platoon (Motor)	28 troopers	28	0

\*Light Vehicles include all vehicles with a mass up to 50 tons.

†Heavy Vehicles include all vehicles with a mass over 50 tons, up to 100 tons.

‡Super-Heavy Vehicles include all vehicles with a mass over 100 tons, up to 200 tons.

§This includes all types of mechanized infantry, such that a Mechanized Tracked (Rifle) Platoon of 28 troopers would require 6 bays, equaling 28 unit personnel and 6 technicians.

bay personnel. The specific composition of bay personnel does not need to be determined for standard rules or any other advanced-rules situations provided in *Tactical Operations*, and so construction rules do not cover this aspect. However, because such specifics are relevant to infantry vs. infantry actions (as well as converting the Marine Points Score back into individuals once the infantry vs. infantry action is over; see p. 205), the Bay Personnel Table (above) allows a player to specifically determine the bay personnel of a given unit/building (if it is not already determined). For example, if aerospace fighters have been deployed, or 'Mechs or vehicles dismounted, and so on, those warriors cannot be included in a Marine Points Score. However, every such unit also includes a single technician, as shown on the table, that would remain behind and can be used in an infantry vs. infantry action roll.

**Civilians:** Civilians never willingly join a fight; most would rather be captured than risk death fighting without any training. In every turn that the defender wishes to include civilians in determining a Marine Points Score, the controlling player must roll against a Target Number of 10. In every turn that the attacker wishes to include civilians in determining a Marine Points Score, the controlling player must roll against a Target Number of 12. If a roll fails, civilians cannot be included when determining a Marine Points Score.

Most Technical Readouts note how many civilians a given unit might have on board; the players will need to determine if said civilians are actually on board. Whether a particular building might have civilians, and how many, is completely up to the discretion of a given playing group and would depend on the time of day and the type of building (factory, mall, office and so on).



**Large-Scale Infantry Vs. Infantry Actions:** Some infantry vs. infantry actions are so large that to determine the exact make-up of an attacking and defending force would take an excessive amount of time. Alternatively, players may simply wish to resolve such actions more quickly than taking the time to determine the specific forces involved.

In such cases, instead of the more detailed Marine Points Score resolution for battle armor provided by the Marine Points Table, players may simply apply the following values across the board: 4 points for each Inner Sphere Battle Armor unit; 5 points for each Clan Battle Armor unit (no battle armor modifiers from the Marine Points Table are applied when using this simplified rule). For all other infantry, apply the standard 1 point for each marine and a half-point for all other non-marine personnel.

*An infantry vs. infantry action after breaching the doors of a Castles Brian is underway (much to the player's shock). The defending player didn't think a breach would be possible, and so he deployed all his marines (his standard infantry) onto the playing area where a raging battle is taking place. Given the various weaponry mounted in the Castles Brian and its transport bays, the player knows he has 309 enlisted/non-rated personnel available. However, he did not provide any further detail on these individuals and so the players determine they are not marines. In an effort to stave off the potential fall of the Castles Brian, while not completely depriving the outside battle of the Castles Brian's defenses, he decides to throw 80 crewmen at the fight.*

*The defender first determines how this will affect the Castles Brian and finds it will add a +2 modifier to all weapon attacks for as long as those crewmen are occupied in the infantry vs. infantry action  $[80 \text{ (crew used in the fight)} / 309 \text{ (total crew of the Castles Brian)} = 25 \text{ percent (checking the Crew Casualties Table, that equates to 2 Crew Hits or a +2 modifier)}]$ .*



FL

*A large group of conventional infantry join in the defense against pirates.*

*The defender then determines his Marine Points Score, which is  $20 [80 \text{ (crew used in the fight)} \times .25 \text{ (non-combat unit crew/fighter pilot modifier)} = 20]$ .*

*The Castles Brian is being attacked by a mixed Star with a Marine Points Score of 100  $[15 \text{ (five Clan standard Salamander battle armor; medium weight class = 3 each)} + 5 \text{ (each mounts a burst fire weapon)} + 5 \text{ (each mounts claws)}] + 10 \text{ (five Clan Aerie battle armor; PA(L) weight class = 2 each)} + 5 \text{ (each mounts Space Operations adaptation)} + 14 \text{ (five standard Clan Elemental battle armor with machine guns; medium weight class = 3 each)} + 5 \text{ (each mounts a burst-fire weapon)} + 25 \text{ (five Clan Rock Golems; assault weight class = 5 each)} + 5 \text{ (each mounts a burst-fire weapon)} + 10 \text{ (five Clan Elementals without battle armor)} = 100]$ .*

### Building Modifier

Buildings cover a vast range of sizes, from a single level, single-hex building, to as large as players wish to build them. The different types of buildings are also a factor, with military structures designed with defense in mind. In reality, clearing out a massive, multi-level fortress—where the defenders know every back door and crawl space—could take days, if not weeks. To reflect a defender's intimate knowledge of such large buildings while keeping these events within a time frame that allows them to play out on a game table with other actions, the following rule equates "time" to a defender's bonus for ease of play.

After determining the defender's Marine Points Score as noted above, multiply that value by the value shown on the Building Modifiers Table. These modifiers only apply if all levels are composed of at least 60 hexes. If some of a building's levels are less than 60 hexes, the modifiers would not apply. For example, a Standard building with 30 levels in which only 23 of those levels were composed of at least 60 hexes each (the top of the building tapers upward) would only apply a .3 modifier to the Marine Points Score; if 24 of the levels were composed of at least 60 hexes, then the modifier would be .4. Round all fractions up.

*The Castles Brian in the example above has ten levels, each with more than 60 hexes per level. This provides a multiplier of 1.9 (a .1 modifier per Castles Brian level above the first). This results in a final defending Marine Points Score of 38  $[20 \text{ (initial Marine Points Score)} \times 1.9 \text{ (unit size modifier)} = 38]$ .*

## BUILDING MODIFIERS TABLE

Building Type	Modifier*
Hangar	No Modifier
Standard	.1 Per 6 Levels
Gun Emplacement/Fortress	.1 Per 3 Levels
Castles Brian	.1 Per Level

\*Beyond the first level

INTRODUCTION

ADVANCED  
GROUND MOVEMENT

ADVANCED  
COMBAT

ADVANCED  
BUILDINGS

ADVANCED  
SUPPORT  
VEHICLES

GENERAL  
RULES

ADVANCED  
SUPPORT VEHICLE  
CONSTRUCTION

ADVANCED  
WEAPONS  
AND EQUIPMENT

INDEX

RECORD SHEETS



### Ratio of Attackers vs. Defenders

After determining the Marine Points Score for each side, determine the ratio of attackers to defenders. It is unlikely that the ratio will exactly match one of those on the Infantry Vs. Infantry Action Table; in such circumstances, round in favor of the defender. For example, a ratio of 2.1:1 in the attacker's favor would become 2:1, while 1.4:1 would become 1:1.

*In the above examples of the Castles Brian, the ratio of attacker to defender is 2:1 [100 (attacker Marine Points Score) / 38 (defender Marine Points Score) = 2.6:1 (rounding in the defender's favor to 2:1)].*

### Infantry vs. Infantry Action Roll

After determining the final attacker to defender ratio, players can begin to resolve the infantry vs. infantry action. The first infantry vs. infantry action roll is made during the End Phase of the turn in which a successful docking or grappling action occurred (in the case of a unit), or after an infantry unit enters a building hex; for airborne aerospace units in space, this occurs at the end of the space turn. Each subsequent infantry vs. infantry action roll is made during the End Phase of every turn following the first infantry vs. infantry action roll until the boarding action is resolved: the defender is defeated, the attacker is defeated or the attacker decides to withdraw (again, for aerospace units in space, this occurs at the End Phase of every space turn). If multiple infantry vs. infantry actions are underway, randomly determine in what order the various infantry vs. infantry action rolls are made.

For each infantry vs. infantry action roll, roll 2D6 and cross-reference the result with the appropriate column on the Infantry Vs. Infantry Action Table (see p. 205). The number to the left of the slash is the percentage of the defender's total strength subtracted from the attacker's strength as casualties, while the number to the right of the slash is the percentage of the attacker's total strength subtracted from the defender's strength. However, the defender in an infantry vs. infantry action has a decisive advantage and suffers only half damage for as long as defending troops remain in full control of the unit or building (until the attack results in a P or an E; see *Letters on the Infantry Vs. Infantry Action Table*; p. 205). Round all fractions up.

Players must determine a new attacker vs. defender ratio for each subsequent infantry vs. infantry action roll, taking into account the changes due to casualties, or the addition of crew members currently on board either unit, or additional infantry (personnel) entering a building hex of a multi-hex building, but not used previously. A separate Marine Points Score should be calculated for any new crew added for a new infantry vs. infantry action roll, with that value added to the previous Marine Points Score after the casualties from previous turns are removed.

When the defender's Marine Points Score reaches zero (or the defender chooses to surrender), the attacker captures the target unit or building. If an R result occurs (see *Letters on the Infantry Vs. Infantry Action Table*; p. 205), or the attacker's Marine Points Score reaches zero, the infantry vs. infantry action fails.

Even if the defender (or attacker) has additional personnel (marines, crew and so on) that could be added to a Marine Points Score on a subsequent turn, if the Marine Points Score reaches zero as a result of an infantry vs. infantry action roll, the unit or building is captured (or the attack is defeated); any remaining personnel (such as the rest of the crew, any civilians on board, any marines not committed to the attack and so on) are assumed to have surrendered (or in the case of an attack, they are retreating). See *Using Captured Units/Buildings* (p. 207) for more information.

**Outside Reinforcements:** Both attacker and target may introduce reinforcements in the form of additional combatants (marines, crew and so on) through other units (or, in the case of a fight in a building, through additional combatants entering a hex of the contested multi-hex building). For aerospace units, regardless of whether the attacker or defender is attempting to reinforce, they can use the recovering rules for friendly units (see p. 86, *TW*) or the Docking/Grappling rules (see p. 199). Large Naval Vessels and Mobile Structures use the appropriate grappling rules (see pp. 200 and 201, respectively); the controlling player determines in which fashion he will attempt to reinforce. During the End Phase of a turn (a space turn for aerospace units in space) in which a unit with reinforcement combatants (marines, crew and so on) has successfully docked or grappled (or been recovered) with the defending unit, the combatants may be included in the new ratio determined before making the infantry vs. infantry action roll for that turn.

**Withdrawal:** During the End Phase of any turn (a space turn for aerospace units in space) in which an infantry vs. infantry action takes place, an attacker may announce that he is withdrawing. This announcement must be made before the infantry vs. infantry action roll is made. An infantry vs. infantry action roll is still made that turn, but the attacker suffers only half damage; any E result becomes a P result and the attacker must withdraw regardless. During the End Phase of the following turn (a space turn for aerospace units in space) after the withdrawal infantry vs. infantry action roll is made, the attacking unit docked or grappled to the defending unit may move normally; in the case of a building, all combatants (that is, infantry) are moved to appropriate adjacent hexes to the building and can move and fight normally.

**Structural Integrity/Internal Structure/Construction Factor Damage:** Infantry vs. infantry action firefights can be just as dangerous to the boarded units as to the combatants involved. Though many units are designed for combat, it is all too easy for the firefight to stray into critical areas. After every infantry vs. infantry action roll, another 2D6 roll should be made. On a result of 12, the unit/building takes damage.

For Small Craft and DropShips, apply a single point of damage to the target aerospace unit's SI.

For Large Naval Vessels, apply a single point of damage to the internal structure of a randomly determined location.

For buildings, apply a single point of damage to every hex on every level (this is not scaled, but applied as a single point of Construction Factor appropriate to the type of building in question).



### Letters on the Infantry vs. Infantry Action Table

An **E** (Eliminated) result replaces some of the percentages shown on the Infantry Vs. Infantry Action Table below. If the E is to the left of the slash, eliminate the attacking force. If the E is to the right of the slash, eliminate the defending force. The non-eliminated force takes damage in the standard way.

Some results may have an additional letter after both percentages. The letters "R" and "P" have the following meanings:

- **R** = Attacker repulsed. The attacking force takes double casualties this turn and is considered to have retreated to their own unit (or out of the building); the defenders regain full control of their unit/building (if the attacker previously achieved a P result). If the defender wishes, he may immediately make his own infantry vs. infantry action roll to go on the offensive and counter-board a docked/grappled attacking unit (in which case, new ratios must be determined).
- **P** = Partial control. The attacking force has seized control of a large portion of the target unit/building, and the defenders immediately take full damage until an R result occurs or the attackers are eliminated.

*Now that the final ratio of attacker to defender is known, the infantry vs. infantry action roll can be made during the End Phase of the turn when the successful grappling occurred.*

*The attacking player rolls 2D6 with a result of 4. Looking on the Infantry Vs. Infantry Action Table, the player notes that this result indicates combat losses of 55 to 35 percent. The attacking marines lose 21 Marine Points [38 (current defending Marine Points Score) x .55 (percent losses) = 20.9 (rounding to 21)]. The defending marines lose 18 Marine Points [100 (current attacking Marine Point Score) x .35 (percent losses) = 35 / 2 (no P result occurred, so the defenders take half damage) = 17.5 (rounding up to 18)].*

*During the End Phase of the following turn, the defender decides that despite the additional damage the Castles Brian is doing against other enemy units, he can't afford to lose the fortress before reinforcements might arrive (they're still too far away to make a difference). He throws in an additional 80 crewmen: this inflicts a +4 modifier to all weapon attacks [160 (total crew used in the fight) / 309 (original total crew of the Castles Brian) = 51 percent (checking the Crew Casualties Table, that equates to 4 Crew Hits or a +4 modifier)], and will provide a new Marine Points Score of 58 [80 (additional crew added to the fight) x .25 (non-combat unit crew/fighter pilot modifier) = 20 x 1.9 (building size modifier) = 38 + 20 (current Marine Points Score of original crew used in the first Boarding Action Roll, minus casualties) = 58]. The attacker's current Marine Points Score is 79, which makes the new ratio 3.2:2, rounded in the defender's favor to 3:2.*

*A new infantry vs. infantry action roll is made with a result of 11. Looking on the Infantry Vs. Infantry Action Table, the player notes this indicates combat losses of 30 percent to 70 percent. The attacking marines lose 24 Marine Points [58 (current defending Marine Points Score) x .30 (percent losses) = 23.2 (rounding to 24)]. However, the "E" result means the defender's Marine Points Score is reduced to 0 and the Castles Brian is captured! Even though the defending player has additional crew, they were not involved in the fight and have surrendered.*

### RE-CONVERTING MARINE POINTS SCORE

After a infantry vs. infantry action ends, players will likely need to convert the Marine Points Score back into individual combatants: battle armor troopers, marines, crew, including specific bay personnel (as shown on the Bay Personnel Table, p. 202), and so on. If a force is composed of only one type of personnel (all marines or all identical battle armor), determining casualties will be easy. However, boarding actions

## INFANTRY VS. INFANTRY ACTION TABLE

2D6 Roll	Attacker to Defender Odds Ratio								
	1 to 3 <	1 to 3	1 to 2	2 to 3	1 to 1	3 to 2	2 to 1	3 to 1	> 3 to 1
2	E/1% (R)	E/1% (R)	E/5% (R)	E/10% (R)	75%/25% (R)	70%/25% (R)	65%/25% (R)	60%/25% (R)	55%/25% (R)
3	E/3% (R)	E/3% (R)	E/7% (R)	E/15% (R)	70%/30% (R)	65%/30%	60%/30%	55%/30%	50%/30%
4	E/5% (R)	E/5% (R)	E/10% (R)	65%/20%	65%/35%	60%/35%	55%/35%	50%/35%	45%/35%
5	E/7% (R)	E/7%	E/15%	60%/25%	60%/40%	55%/40%	50%/40%	45%/40%	40%/40%
6	E/10%	E/10%	E/20%	55%/30%	55%/45%	50%/45%	45%/45%	40%/45%	35%/45%
7	E/15%	E/15%	E/25%	50%/35%	50%/50%	45%/50%	40%/50%	35%/50%	30%/50%
8	E/20%	E/20%	45%/30%	45%/40%	45%/55%	40%/55%	35%/55%	30%/55%	25%/55%
9	E/25%	E/25%	40%/35%	40%/45%	40%/60%	35%/60%	30%/60%	25%/E (P)	20%/E (P)
10	E/30%	E/30%	35%/40%	35%/50%	35%/65%	30%/65% (P)	25%/E (P)	20%/E (P)	15%/E (P)
11	E/35%	30%/35%	30%/45% (P)	30%/55% (P)	30%/70% (P)	25%/E (P)	20%/E (P)	15%/E (P)	10%/E (P)
12	30%/40% (P)	25%/40% (P)	25%/50% (P)	25%/60% (P)	25%/75% (P)	20%/E (P)	15%/E (P)	10%/E (P)	5%/E (P)

Results given as: Percentage of defending strength subtracted from attacker strength as casualties / percentage of attacker strength subtracted from defending strength as casualties. Until a P result occurs, the defenders take only half of the indicated casualties.

INTRODUCTION

ADVANCED GROUND MOVEMENT

ADVANCED COMBAT

ADVANCED BUILDINGS

ADVANCED SUPPORT VEHICLES

GENERAL RULES

ADVANCED SUPPORT VEHICLE CONSTRUCTION

ADVANCED WEAPONS AND EQUIPMENT

INDEX

RECORD SHEETS



are seldom so tidy and instead will likely involve numerous different personnel types.

Players have two options for conversion, one easier to implement and recommended for large-scale infantry vs. infantry actions (especially when the specifics of a force's make-up—for example, battle armor—are unknown). The more complex version provides a slightly more realistic way of determining casualties.

In both conversion methods, the player first determines the percent of casualties suffered by the original force. For example, if a player had a Marine Points Score of 23 and lost 13 points, the percent of casualties is  $56$  [ $13$  (Marine Points Score casualty value) /  $23$  (original Marine Points Score) =  $.56$ , or  $56$  percent]. In the case of the defender, the player should use the Marine Points Score before the building modifier was applied (see p. 203).

In the simpler conversion method, the percentage of casualties is applied to all different personnel types equally (round all fractions down). For example, if a player deployed 22 crew, 7 marines and 4 battle armor in an infantry vs. infantry action and took 43 percent casualties, he would apply that percent to each type of group to determine how many of each are removed as casualties: 9 crew [ $22$  (original crew deployed)  $\times$   $.43$  (percent of casualties) =  $9.46$  (rounded down to 9)], 3 marines [ $7$  (original marines deployed)  $\times$   $.43$  (percent of casualties) =  $3.01$  (rounded down to 3)] and 1 battle armor [ $4$  (original battle armor deployed)  $\times$   $.43$  (percent of casualties) =  $1.72$  (rounded down to 1)].

The more complex version takes into account that different battle armor can be fielded, with heavier battle armor able to withstand the rigors of combat longer than lighter battle armor (and of course, all battle armor can take more damage than any unarmored personnel). This conversion assumes that the entire make-up of a force involved in an infantry vs. infantry action (specifically the individual battle armor involved) is known.

First, apply casualty percentages to all non-battle armor personnel as shown above, except in the case of Elementals or marines wearing armor with a Damage Divisor of 2 or more (see Marine Points Table, p. 202). In these cases, divide the final casualty number in half (rounding down) to determine how many such troopers were eliminated.

Next, for battle armor, once the number of troopers eliminated has been determined, multiply that value by 10 to determine the total standard-scale damage. Then start applying that damage, 1 point at a time, to each battle armor trooper involved in the infantry vs. infantry action. Always apply the damage to the lightest weight class battle armor first, then move on to the heavier. If there are fewer points to assign than remaining battle armor of the same weight class, randomly determine which troopers receive that damage.

If reinforcements were added, especially from two different sources, some player adjudication will be required. For example, if a unit with a Marine Points Score of 20 was in an infantry vs. infantry action that lasted five turns, and on Turn 3 another Marine Points Score of 20 was added, and at the end of the boarding action more than 20 points of casualties occurred, a good argument could be made that the troopers in the first Marine Points Score of 20 were completely eliminated simply because they were involved in the conflict for a much longer time. Use good judgment and roll a die to resolve any disagreements if the players cannot come to a consensus.

### CREW LOSSES AND CREW HITS

The loss of crew members during an infantry vs. infantry action may adversely affect a unit's performance (as well as a building mounting weapons) in combat; the more crew it has lost, the less effective the unit. The Crew Casualties Table provides an equivalency between crew losses and the number of Pilot/Crew hits taken by the unit. Each crew hit inflicts a cumulative +1 weapon attack and Piloting Skill Roll/Control Roll modifier.

These modifiers apply for the rest of the scenario.

### CREW CASUALTIES TABLE

Percentage of Crew Casualties	Crew Hits	Percentage of Crew Casualties	Crew Hits
5–20	1	51–65	4
21–35	2	66–80	5
36–50	3	81–100	6



Conventional infantry attempt to hold off an elite squad of Kage by taking shelter in a refueling station.



## USING A CAPTURED UNIT/BUILDING

Once a unit is captured, the new controlling player may have a chance to put it into the fight on his side. Use the following rules to govern this situation.

A certain amount of down time will occur as the new crew takes control. Depending on the type of captured unit/building, a number of turns (space turns in the case of aerospace units in space) will occur where the unit cannot expend any MP or fire any weapons, and aerospace units will continue to move at their last velocity and heading.

For aerospace units, a Small Craft has 1 turn of down time and a DropShip 2 turns.

For Large Naval Vessels, a Template A, B and C ship has 1 turn of down time, while Templates D and E ships have 2 turns.

For a building, each 3 levels equals 1 down-time turn. In the case of the Castles Brian from the previous example, down time would take 4 turns.

During this time, the unit is still counted toward Initiative, but for the new controlling player. During the Movement Phase (Aerospace or Ground, as appropriate) of the turn following the required inactive turns, based on its type and size as described above, the unit may move and fire normally, with the additional restrictions noted below. For example, if a DropShip is captured in Space Turn 5, then Space Turns 6 and 7 will elapse with the DropShip traveling at its last velocity and heading each turn. During the Movement Phase (Aerospace) of Turn 8, the captured DropShip can move freely.

Next, the captured crew and crew casualties must be taken into account. Depending upon the crew casualties that have occurred, additional attack and Piloting Skill/Control Roll modifiers are still in place (as noted under *Crew Losses and Crew Hits*, p. 206). An additional +2 modifier is also applied, representing crew that must be held hostage (likely many of the officers), as well as the equivalent of 1 additional crew hit to represent the general uncooperativeness of the captured crew.

The new controlling player can offset these disadvantages by transferring crew onto the captured unit. If the player has the crew available (for example, a DropShip capturing a Small Craft, or a lot of infantry to pour into a building), they can completely replace the original crew and fully eliminate all additional attack and Piloting Skill/Control Roll modifiers; in this case, at least 4 battle armor or 7 marines, or 28 crew/other personnel, must be tasked with controlling the captured crew in a brig or jail. In all cases, the unit losing the transferred crew/personnel must take into account the Crew Casualties Table as well, applying appropriate modifiers for how much crew is lost to the captured unit.

**Sabotage:** Even with all those precautions, there's still a chance that the belligerent, captured crew will try to sabotage the unit. During the End Phase of any turn in which captured crew/personnel are used to operate the unit (meaning they are not in the brig), roll 2D6. On a result of 12, sabotage occurs. Apply 1 point of damage to the unit's Structural Integrity (for Small Craft or Large Craft), or to the Internal Structure at a randomly determined location; in all instances, a potential critical hit will need to be rolled for such damage. In the case of buildings, randomly determine a critical hit against a weapon system.

In addition, assign a further random critical hit; first randomly determine the location column on the appropriate Hit Location Table and then roll for the specific critical hit.

Finally, the unit may not move or fire in the turn following the sabotage (a building cannot make any attacks), as its new masters attempt to deal with the aftermath. Aerospace units continue with the same velocity and heading during that turn.

## MINEFIELDS

The *BattleTech* rules offer the use of four forms of minefields: conventional fields, command-detonated fields, vibrabomb fields and active fields. While an EMP minefield exists, it is treated exactly like a command-detonated or vibrabomb minefield for purposes of how it detonates, except it is always eliminated completely once it explodes (see *EMP Mine*, p. 365).

Players assign minefields to hexes during game setup, secretly writing down the type and location of each field. The number of minefields available to each player may be determined by the scenario or agreed to by all players before beginning play. Though some scenarios may designate minefield locations, only the referee or controlling player should know those locations.

If the players cannot agree, but wish to include mines, each can secretly choose up to 5 hexes on the playing area to place mines. This number is for a playing area composed of four maps. If players are using a truly large area, they may wish to alter this number: a total of 5 hexes per side for every four mapsheets used (for example, a twelve-mapsheet playing area would allow 15 mined hexes per side). However, regardless of the size of the playing area, no player can place more than 5 mined hexes per mapsheet.

**Area-Effect Weapon:** Minefield attacks are area-effect weapons, and so all rules that apply to such weapons also apply to minefield attacks.

**Buildings:** Use the Area-Effect Weapons rules (see p. 172, *TW*), as appropriate, for the interaction of minefields and buildings; remember to scale damage if using the building rules from this rulebook, as appropriate (see *Scaled Damage*, p. 126). If a minefield is laid by a weapon system (a bomb, artillery, LRM and so on) in a building hex, it is automatically laid on the building's roof; rolls for determining if the minefield detonates are only made if a unit enters the hex on the building's roof. If a minefield is laid in a bridge hex, randomly determine if it landed on the bridge or is on the underlying terrain.

**Different Types of Minefield:** While this section covers the basics of minefields as they apply to all situations, different types of minefields provide subtle variations that players can use to different effects (see *Mines in Advanced Weapons and Equipment*, p. 364).

**Infantry:** All infantry units entering a minefield apply a -1 modifier to any die roll to determine if the minefield explodes.

**Vehicles:** When a ground vehicle suffers damage from any minefield, it must automatically roll once on the Motive System Damage Table, as though the damage came from the side.

INTRODUCTION

ADVANCED  
GROUND MOVEMENT

ADVANCED  
COMBAT

ADVANCED  
BUILDINGS

ADVANCED  
SUPPORT  
VEHICLES

GENERAL  
RULES

ADVANCED  
SUPPORT VEHICLE  
CONSTRUCTION

ADVANCED  
WEAPONS  
AND EQUIPMENT

INDEX

RECORD SHEETS



**Weapon-Delivered Minefields:** Numerous weapon systems (such as LRMs, artillery and bombs) can be used to actively deploy most minefields right in the midst of scenarios. These different weapon systems are all found in the *Advanced Weapons and Equipment* section, starting on p. 274. Use the rules for the weapon system in question until the minefield is successfully deployed in a hex(s), after which use the appropriate rules as follows for the specific type of minefield laid.

Some mines are designed for use in a water hex (sea mines) or a space hex (space mines). Those specific types of mines, and the rules for their use, are also found under *Mines* in the *Advanced Weapons and Equipment* section.

If a weapon-delivered minefield does not exactly match the Minefield Density Table, use the next highest rating. For example, an MML 3 would deliver a 3-point minefield, and since a 5-point minefield is the next highest rating, players would roll on that row (i.e. 9+); an MML 12 would deliver a 12-point minefield, and since a 15-point minefield is the next highest rating, players would roll on that row (i.e. 8+); and so on.

### MINEFIELD DENSITY TABLE

Minefield Density*	Target Number
5- or 10-point	9+
15- or 20-point	8+
25- or 30-point	7+

\*The EMP mine (see p. 365) cannot be weapon-delivered.



Word of Blake battle armor sweep for minefields ahead of an on-coming force.

### CONVENTIONAL MINEFIELDS

Once the players have determined the number of hexes that will be mined before the start of play, they must determine the minefield density, as shown on the Minefield Density Table. This may be designated by the scenario, randomly determined, or the players can agree on a specific density for all minefields to be placed before play begins. This will not only determine how much damage a minefield inflicts, but also the dice roll required to determine if the minefield will inflict damage on a target entering the hex.

Whenever any ground unit ('Mech, ground vehicle or infantry, friend or foe) enters one or more of these designated hexes (whether through voluntary or involuntary movement such as unit displacement and accidental falls from above), the minefield automatically attacks the unit. The player controlling the mines rolls 2D6 and compares the result to the Minefield Density Table. If the result is equal to or greater than the number in the Dice Roll (2D6) column, the minefield has exploded and damaged the target.

Resolve the attack and apply the damage before the unit continues its movement. The player controlling the minefield player may make this roll secretly, so that if the minefield does not explode, its location remains hidden. Damage is inflicted against the Front side of the unit entering the hex. To determine damage to 'Mechs entering a minefield, use the BattleMech Kick Location Table.

Every time a conventional minefield explodes, its density rating may be reduced. The controlling player of the minefield rolls 2D6 against the Dice Roll (2D6) column of the Minefield Density Table. If the result is equal to or greater than the number in that column, the rating is reduced 1 level. For example, a 30-point minefield is reduced to a 25-point minefield, or a 10-point minefield is reduced to a 5-point minefield. Conventional minefields are never reduced in this fashion past a 5-point density throughout the scenario, unless cleared (see *Clearing Minefields*, p. 210).

Finally, players can increase the density rating of a minefield by laying mines through the use of bombs, LRMs and so on (see *Weapon-Delivered Minefields*, p. 210). For example, a 15-point minefield laid into a 10-point minefield hex becomes a 25-point density minefield. No minefield can be greater than a 30-point density in any hex, however.

**Command-Detoted, Vibrabomb and Active Minefields:** Players can choose two options when determining how often a specific command-detonated (see p. 209), vibrabomb (see p. 209) or active minefield (see p. 209) can be used. As these minefields can be more effective than conventional minefields, the first option is to have it explode only once during a scenario; if it explodes, it is eliminated. The second option follows the standard rules for density depletion as for conventional minefields, except that each type of minefield is automatically reduced; for example, a 20-point vibrabomb minefield that explodes automatically is reduced to a 15-point minefield. Additionally, unlike a conventional minefield, a 5-point command-detonated, vibrabomb or active minefield that explodes will be eliminated. Players should agree before play begins as to which manner of elimination these additional minefields will follow.

**EMP Minefields:** As indicated above, EMP minefields may detonate only once per scenario. The pulse from the exploding EMP mines will disable all other EMP mines in the same hex (see *EMP Mine*, p. 365).



**Crashing Airborne Units:** A crashing airborne non-aero-space unit that enters a mined hex detonates the hex on a roll of 7+, but has a chance of clearing the minefield (see *Clearing Minefields*, p. 210); a crashing aerospace unit automatically detonates the hex, applying damage appropriately, but also automatically clears the hex.

**Falling:** A 'Mech that falls in a mined hex (regardless of whether it started the phase in the hex, or entered the hex and fell during movement) only detonates the hex on a roll of 12 (as opposed to the standard 7+, 8+ or 9+); a 'Mech entering a hex and then falling in that hex during the same movement phase would need to make a roll for entering the hex and one for falling.

**Aerospace Units Landing/Lifting Off:** If a landing or lifting-off fighter, aerodyne Small Craft, aerodyne DropShip or Fixed-Wing Support Vehicle enters a mined hex, the roll to determine if the minefield attacks that unit is made immediately, resolving all damage, before continuing the landing/lift-off maneuver. In the case of fighters and Fixed-Wing Support Vehicles, if the minefield attacks the unit, the unit in question must make an immediate Control Roll, applying all standard modifiers, to make sure the maneuver in question is a success; a failure means the landing/take-off failed (use the rules on pp. 87-88, *TW*, to resolve such situations).

A landing or lifting-off Airship Support Vehicle will never detonate a conventional minefield (though dismounting units are still required to roll for an attack as described above).

**Minesweeping Engineers:** These specialized infantry troops never automatically roll to determine if a conventional minefield detonates when they enter a mined hex; the minefield may only detonate when they are attempting to clear the hex (see *Specialized Infantry*, p. 340).

**Mobile Structures:** A Mobile Structure automatically detonates a conventional minefield—double the standard damage and apply normally—but also clears the minefield (see *Clearing Minefields*, p. 210).

**Vehicles:** Hover vehicles (and WiGEs moving along the ground, as opposed to moving 1 elevation above the underlying terrain) entering a hex with a conventional minefield only detonate the mines on a roll of 12 (as opposed to 7+, 8+ or 9+ for other types of ground units).

Airborne WiGE and VTOL vehicles entering a minefield hex never detonate the minefield unless they land; in which case, roll for the standard result of 7+, 8+ or 9+ to determine if they detonate the minefield.

## COMMAND-DETONATED MINEFIELDS

As with conventional minefields, players should determine the minefield density of any command-detonated minefields to be placed before play begins.

At any time during the turn sequence (that includes any phase, from Movement to End Phase) that a defending unit has line of sight to a unit occupying a mined hex (the defending unit does not need to have LOS to the underlying terrain in the hex, as the location of the mine is known), the defender may detonate any or all of these mines. This can interrupt any other action, including movement, weapons fire and so on; all damage and results from a minefield are immediately resolved, before returning to the resolution of any other actions.

Detonating a command-detonated minefield inflicts damage equal to the minefield density determined by the players before the beginning of the game to each unit occupying the target hex, as well as damage equal to half (round down) the minefield density to each unit in each adjacent hex.

Apply damage from command-detonated mines to the Front side of the unit. To determine damage to BattleMechs entering a minefield, use the BattleMech Kick Location Table. Resolve the attack and apply the damage as soon as the explosion occurs.

**Minesweeping Engineers:** The controlling player can detonate a command-detonated minefield after minesweeping engineers have entered the mined hex but before the controlling players of the engineers attempt to clear the hex, provided all other criteria above are met (see *Specialized Infantry*, p. 340).

## VIBRABOMB MINEFIELDS

As with conventional minefields, players should determine the minefield density of any vibrabomb minefields to be placed before play begins.

Treat a vibrabomb like a conventional mine, with the following exceptions.

Vibrabombs can only be set off by the unique vibrations created by an approaching 'Mech. No other units can trigger vibrabombs. Any 'Mech can set off a vibrabomb, and vibrabombs go off automatically.

Vibrabombs have a variable sensitivity, and when placed must be set to respond to a specific mass. 'Mechs massing 10 or more tons lighter than the vibrabomb setting will not set off the minefield. A 'Mech massing more than 10 tons heavier than the setting will set off the minefield at a distance of 1 hex for each 10 full tons by which it is heavier than the bombs' setting.

For example, if a vibrabomb minefield is set to respond to a 40-ton 'Mech, and a 75-ton *Orion* enters a hex three hexes away, the field explodes. A 30-ton *Javelin* walking directly through the hex containing the a vibrabomb mine would not set it off.

A unit occupying the same hex as an exploding vibrabomb takes damage equal to the minefield density determined by the players before the beginning of the game, as shown on the Minefield Density Table, to its Front side. Exploding vibrabombs do not affect adjacent hexes. Use the 'Mech Kick Location Table to determine damage to a BattleMech.

**Jumping Units:** Units that expend Jumping MP must determine if they set off a vibrabomb minefield when they land in the target hex or any adjacent hexes depending upon the weight of the unit in question (see above), just as if they had moved along the ground to enter that hex.

## ACTIVE MINEFIELDS

As with conventional minefields, players should determine the minefield density of any active minefields to be placed before play begins.

Treat an active minefield like a conventional minefield, with the following exceptions.

Any time a ground unit ('Mech, infantry, vehicle and so on, friend or foe) expending Jumping MP passes over a hex with an active minefield, it must make a roll for the hex exactly as

INTRODUCTION

ADVANCED  
GROUND MOVEMENT

ADVANCED  
COMBAT

ADVANCED  
BUILDINGS

ADVANCED  
SUPPORT  
VEHICLES

GENERAL  
RULES

ADVANCED  
SUPPORT VEHICLE  
CONSTRUCTION

ADVANCED  
WEAPONS  
AND EQUIPMENT

INDEX

RECORD SHEETS



if the unit had entered the hex using non-jumping movement (entering a hex while moving along the ground will not detonate an active minefield). On a 2D6 roll of 9 or greater, the minefield explodes, causing standard damage. Any Piloting Skill Rolls that need to be made as a result of this damage are resolved when the unit reaches the target hex of its jump.

Airborne units (including aerospace units, VTOLs, WiGEs, infantry expending VTOL MP and so on) entering a hex, regardless of elevation, are not affected by active minefields, nor are any other units that enter an active minefield using any other type of movement.

### COMBINED MINEFIELDS

Though no specific minefield type can be greater than a 30-point minefield, multiple minefield types can fill the same hex, whether at the same or different densities. For example, a single hex might contain a 30-point conventional minefield, 15-point command-detonated minefield, 15-point vibrabomb minefield and a 5-point active minefield.

Whenever a minefield explodes, in addition to the controlling player rolling to determine if that minefield's density is reduced (see *Conventional Minefields*, p. 208), the controlling player(s) of the additional minefield(s) types must also make rolls to determine if those additional minefields were reduced.

This could mean that a minefield might need to make more than a single dice roll to reduce in a single turn. For example, a command-detonated bomb explodes when a 'Mech enters the hex (the players are using the rule that such bombs have a density, as opposed to being eliminated the first time they are used) and a conventional minefield in that same hex also explodes. The player controlling the minefields will need to make two rolls (one for the conventional minefield's successful detonation and one for the successful detonation of the command-detonated minefield), while the command-detonated minefield is automatically reduced for its own successful explosion and then the player would need to make a roll for a possible reduction due to the successful detonation of the conventional minefield.

Apply a -1 modifier to the die roll if the minefield was a lesser density; apply a +1 modifier if the minefield was of greater density. For example, a 15-point conventional minefield explodes in a hex containing a 5-point active minefield and a 20-point vibrabomb minefield. A +1 modifier is applied to the dice roll result to see if the vibrabomb minefield is reduced, while a -1 modifier is applied to the active minefield roll.

In all instances, if a minefield is reduced due to the explosion of another minefield, it does no damage.

### WEAPON-DELIVERED MINEFIELDS

Unlike pre-determined minefields before the start of play, which are always hidden until detonated (unless using the advanced *Active Probe* rules; see p. 99), weapon-delivered minefields may be spotted by an opponent.

As with command-detonated, vibrabomb and active-minefields, players can determine how such weapon-delivered minefields may be spotted in two ways. As usual, players should determine before play begins which rule set they will use.

The first is simple and straightforward. Any weapon-delivered minefield, regardless of which player places it, is automatically visible to all players.

While easy to use and implement, not only is the first option not very realistic, but it cuts down on the tactics that can be employed by players when laying weapon-delivered minefields. The second option, while more complex, allows for more advanced tactics. In most of the instances below, it is up to the player laying the minefield to determine if the opponent can see the minefield, and either make it visible or not (a neutral gamemaster for this type of minefield laying can be very useful).

- If a friendly unit has LOS to the target hex where a weapon-delivered minefield is laid, then that minefield is automatically visible.
- If a friendly unit does not have LOS to the target hex where a weapon-delivered minefield is laid, nor does a friendly unit have LOS to the attacker that laid the minefield, the minefield is hidden just as if it had been placed before play began.
- If a friendly unit does not have LOS to the target hex where a weapon-delivered minefield is laid, but a friendly unit does have LOS to the attacker that laid the minefield, a die roll is made to see if the unit can determine where the minefield was laid. The Base Target Number is 4, modified for terrain between the friendly unit and the attacker, target movement and attacker movement modifiers. Only a single roll is made on a side for each minefield laid, with the controlling player using the unit with the lowest modified target number. If the roll result is equal to or greater than the modified target number, then the minefield is visible. If the roll fails, the minefield is hidden just as if it had been placed before play began.
- Finally, anytime a unit mounting an active probe ends its movement (or at any point during its movement if using the expanded active probe rules; see p. 99) and the effective radius of the probe covers any hex with an enemy minefield, the controlling player of that minefield must make a roll. On a result of 7+, any weapon-delivered minefields are revealed; on a result of 10+, any pre-designated minefields laid at the start of the scenario are revealed (see *Active Probes* in *Advanced Combat*, p. 99).

### CLEARING MINEFIELDS

Clearing minefields is a dangerous job requiring great skill and finesse, so it is usually assigned to infantry. If an enemy infantry unit ends its turn on the ground in a mined hex, the opposing player must be informed that his unit has entered a mined hex, even if the field has not been detonated.

Infantry that spends 1 Movement Phase in a mined hex without moving may elect to clear the field instead of attacking during the Weapon and Physical Attack phases. If the infantry unit rolls 2D6 with a result of 10 or higher in the Weapon Attack Phase, they have successfully cleared the field. A dice roll result of 5 or less means the minefield exploded; the infantry takes normal damage. Conventional fields remain active after an accidental detonation, but their density is reduced (though never below 5-points, if using that rule). Accidental detonation clears vibrabomb, command-detonated and active minefields. If multiple infantry units are attempting to clear the same hex, all units must make a successful roll to clear the minefield. If any unit rolls a 5 or less, all units attempting to clear the hex take damage.

Note that such a roll to clear a minefield only applies to a single type of minefield per hex. If a hex contains different types of mine-



fields (see *Combined Minefields*, p. 210), then each minefield type must be cleared separately. While multiple infantry units in a hex can clear multiple minefield types in the same turn, a single infantry unit can only attempt to clear one type of minefield per turn. A minefield that is accidentally detonated, however, can still potentially reduce other minefield types in the same hex (see *Combined Minefields*, p. 210).

Except in cases where a minefield is automatically cleared—such as landing spheroid aerospace units or Mobile Structures, in which case all types of minefields in a hex are automatically cleared—any die rolls made under any of the following rules to clear a minefield must be made for each type of minefield located in a hex. For example, an LRM-20 is fired into a hex containing conventional, vibrabomb and command-detonated minefields. A separate die roll result of 5 or better must be made three times to see if all three fields have been cleared. Minefields cleared in this fashion do not explode and so do not require a roll for any minefields remaining to see if they were reduced (see *Conventional Minefields*, p. 208).

**Artillery:** A player may use artillery fire to clear a minefield. The player must designate the fire mission to clear the minefield. When the fire mission hits the hex, the player rolls 2D6. On a result of 5 or better, the strike clears the minefield. Mines cleared in this way do no damage, and clearing artillery fire does not affect adjacent hexes (regardless of the ordnance used). However, artillery fire does normal damage to units occupying the mined hex.

Because artillery is an area effect weapon, however, any time the target hex of an artillery attack (not any adjacent hexes) contains a minefield, even if the artillery was not designated to clear the minefield, the controlling player should roll 2D6. On a result of 10+, the minefield is cleared; the mines do no damage.

**Crashing Airborne Units:** A crashing aerospace unit automatically clears a minefield, though the hex automatically detonates; apply damage normally. If a crashing non-aerospace unit detonates a minefield, roll another 2D6. On a result of 5 or better, the minefield is cleared.

**Landing Aerospace Units:** A landing spheroid Small Craft or spheroid DropShip automatically clears a mined hex; no damage is applied to the landing unit.

**Missiles:** Unless using special Mine Clearance Munitions (see p. 370), a player may use an LRM-20; Rocket Launcher 20; MRM-20, -30 or -40; ATM 12 (HE or standard) or ATM 9 (HE) to clear a minefield (but no other type of missile attack). The player must designate the attack to clear the minefield. When the attack hits the hex, the player rolls 2D6. On a result of 5 or better, the strike clears the minefield. Mines cleared in this way do no damage. Missile salvos fired to clear a minefield do not affect adjacent hexes.

**Minesweepers:** Use the rules for Minesweepers in the *Advanced Weapons and Equipment* section for clearing a minefield (see *Minesweeper*, p. 326).

**Minesweeping Engineers:** These specialized infantry troops have their own rules for clearing a minefield (see *Specialized Infantry*, p. 341).

**Mobile Structures:** A Mobile Structure automatically clears a minefield (though it also automatically detonates the minefield; damage is doubled).

## MORALE

Common wisdom has it that breaking soldiers' morale is easier than breaking their bodies. In standard play, morale is not an issue. The standard rules assume that every soldier will fight to the death if the player demands it. The following optional rules add the dimension of morale to *BattleTech*, introducing the possibility that a player's troops may flee the field even if ordered to hold their ground.

**Mobile Structures:** Mobile Structures are never affected by morale.

**Tactical Vs. Strategic:** The following rules only cover "tactical morale;" morale as it occurs directly in a scenario. However, morale can be even more insidious off the battlefield. Such "strategic morale" rules are covered in *Strategic Operations*.

### MORALE CHECKS

Whether a unit must make a Morale Check depends on the unit type and the damage it receives.

**Infernos:** Given the horrific nature of inferno weapons (and the fact that even MechWarriors have a deep-seated fear of burning alive), a successful inferno attack automatically causes a Morale Check for all units affected (see p. 141, *TW*), applying the appropriate modifier from the Morale Table. An inferno attack is a special case, where even units marked on the Morale Table as never needing to make Morale Checks must still make one (with applicable modifiers); in this instance, the Target Number is 1.

**Cruise Missile Attack:** A cruise missile attack (see Artillery Ordnance Table, p. 184) automatically requires a Morale Check for all units damaged by the attack. As with an inferno attack, a cruise missile attack is a special case where even units marked on the Morale Table as never needing to make Morale Checks must still make one (with applicable modifiers); in this instance, the Target Number is 1.

### Non-Infantry Units

If a non-infantry unit suffers crippling damage (see *Crippling Damage*, p. 258, *TW*), it must make a Morale Check at the end of the phase in which the damage occurred.

### Conventional Infantry

A conventional infantry unit must make a Morale Check at the end of any phase in which it lost a quarter (round down) or more of the troopers it had at the start of the phase. For example, a conventional infantry platoon of 25 troopers that starts a phase at full strength must make a Morale Check if it loses 6 [25 troopers (strength at start of phase) x .25 = 6.25, rounded down] or more troopers in that phase.

### Battle Armor

A battle armor unit must make a Morale Check at the end of any phase in which it lost half or more of the troopers it had at the start of the phase. For example, a full-strength Clan battle armor Point that lost 2 troopers in a phase would not need to make a Morale Check, but if it lost 3, a Morale Check would be required.

INTRODUCTION

ADVANCED  
GROUND MOVEMENT

ADVANCED  
COMBAT

ADVANCED  
BUILDINGS

ADVANCED  
SUPPORT  
VEHICLES

GENERAL  
RULES

ADVANCED  
SUPPORT VEHICLE  
CONSTRUCTION

ADVANCED  
WEAPONS  
AND EQUIPMENT

INDEX

RECORD SHEETS



### Making the Morale Check

To make a Morale Check, roll 2D6 for the unit type in question and consult the Morale Table. The result must be equal to or greater than the target number shown to avoid the unit breaking (if there is a dash, then a Morale Check is never made; see *Morale Checks*, p. 211, for the exceptions).

For infantry only, apply the modifiers on the table for artillery, fire and attacks from 'Mechs in line of sight—all these attack types are particularly damaging to morale. Apply only the highest relevant modifier to the target number, and apply it only once. For example, if the infantry unit takes damage from attacks by three 'Mechs, the modifier remains +1. An attack by a 'Mech using a flamer would have a +3 modifier, representing the flamer attack. Negative modifiers apply if the unit is equipped with battle armor or if it is inside a building. Negative modifiers are cumulative.

### BROKEN MORALE

If the Morale Check fails, the unit's morale is broken. Starting in a subsequent turn, for that unit, the Forced Withdrawal rules (see p. 258, *TW*) are in effect.

Additionally, for infantry only, during each turn that a unit's morale is broken and it moves toward its home map edge, it must also move toward cover, assuming cover is available, in order to eliminate LOS between itself and any enemy units. If no concealing hills or woods (or other terrain) are close enough for the unit to

reach in a single turn, the infantry will automatically start digging in (see *Digging In*, p. 108). If the unit is damaged again, it will move out of that hex toward the home map edge once more. However, once again, if no concealing hills or woods (or other terrain) are available, the unit starts digging in.

Also, a broken infantry unit cannot act as a spotter for indirect attacks, artillery attacks and so on (they cannot spot or use TAG—if so equipped—to spot and so on). However, any electronics on the unit continue to function normally.

Finally, if a broken infantry unit loses a quarter or more of the troopers it had at the start of the phase, it must make another Morale Check, with an additional +1 modifier to the target number. If a broken unit fails a Morale Check, it is routed. A routed unit is demoralized by panic, and must move as fast as it can away from enemy units in as straight a line as possible, all the while attempting to move toward its home edge. A routed unit may make no attacks, nor take any action except to move its maximum MP allowance away from enemy units and toward its home edge of the playing area.

**Forced Withdrawal:** If players are already using the Forced Withdrawal rules in their scenario and also wish to include the effects of morale, non-infantry units apply a +3 modifier to all weapon and physical attacks, as well as all Piloting Skill Rolls, to reflect how badly the crippling damage and the need to withdraw have affected the unit in question.

## MORALE TABLES

Experience Level	BattleMechs Morale Target	Combat Vehicles Morale Target	Infantry Morale Target	Support Vehicles Morale Target
Green	4	6	9	10
Regular	2	4	6	7
Veteran	—§§	2	4	5
Elite	—§§	—§§	2	2

\*Includes ProtoMechs and aerospace fighters.

†Includes military conventional fighters, Small Craft, DropShips and WarShips.

‡Includes military Support Vehicles, JumpShips and Space Stations.

§Includes IndustrialMechs (unless piloted by a military MechWarrior, in which case treat as a Combat Vehicle) and all civilian aerospace units.

§§See *Infernos* and *Cruise Missile Attack* (see p. 211).

Special Source Modifier (All)	Target Modifier
Inferno	+1/+3*
Cruise Missile	+2

\*The modifier to the left of the slash is for all non-infantry units, the modifier to the right of the slash for infantry.

Attack Source Modifier (Infantry Only)	Target Modifier
BattleMech in LOS	+1
Artillery	+2
Flamer or Fire	+3
Elite	—§§

Other Modifiers Modifier (Infantry Only)	Target Modifier
Broken Morale	+1
<i>Cumulative Modifiers</i>	
Light or Medium Battle Armor Unit	-1
Heavy or Assault Battle Armor Unit	-2
Anti-'Mech Skill of 5 or less	-1
Conventional Infantry with Armor (see p. 317)	-1
Unit in Building	-2
Unit Dug In	-2



## RECOVERING NERVE TABLE

**NOTE:** These modifiers only apply if a friendly unit/commander is within seventeen hexes of the unit attempting to recover its nerve.

Commanders*	Target Modifier
Sub-force Commander in LOS	-1
Force Commander in LOS	-2

Infantry Only	Target Modifier
Friendly non-'Mech, non-infantry unit in LOS	-1
Friendly 'Mech in LOS	-2
Another Routed Infantry Unit in LOS	+1
Another Routed Non-Infantry Unit in LOS	+2
Routed Unit	+3

\*Only applies if Commanders (see p. 191) are in use.

### RECOVERING NERVE

A broken unit may attempt to recover its nerve during the End Phase of each turn after the turn in which it broke. Therefore, such a unit will always spend at least one turn broken before it has a chance to recover.

In order to recover its nerve, a broken unit must make a Morale Check against its base morale target number, applying the modifiers found on the Recovering Nerve Table (all modifiers are cumulative). If the roll is successful, the unit recovers its nerve and may function normally. If it fails, the unit stays broken.

**Forced Withdrawal:** The rules above assume players are not using the Forced Withdrawal rules in conjunction with morale rules. If the Forced Withdrawal rules are being used, eliminate the +3 modifier for a unit that recovers its nerve, but it still must follow all the standard Forced Withdrawal rules.



SL

A Lyran convoy nears the front lines of battle bringing much needed supplies.

## REARMING UNDER FIRE

In the midst of a battle, some commanders may find that the extreme danger to troops attempting to rearm is worth the risk to ensure victory after a long, hard-fought campaign when ammunition is depleted. If a player wishes to load ammunition during a scenario, use the following rules (see *Rearming Aerospace Units*, p. 214, for rules concerning rearming airborne aerospace units).

Use the *Loading and Unloading* rules under *Cargo Carriers* (see p. 261, p. TW), with the following changes:

- The correct type of ammunition must be used to rearm (in standard 1-ton or half-ton allotments, depending on the weapon) and must be on a unit in the same or an adjacent hex to the unit being loaded. For example, if attempting to rearm a unit that mounts an LB 10-X AC, only 1-ton lots of LB 10-X AC can be used.
- For each three turns, 1 ton of ammunition is loaded.
- For each 1 ton of ammunition successfully loaded, the controlling player immediately rolls 2D6. On a result of 11 or 12, the ammunition explodes, just as if it was hit by an attack (see below); this represents the extreme haste with which the ammo is being loaded.
- If a player is attempting to load a 'Mech and no other 'Mech is available to do the loading (or no unit with a lift hoist; see p. 136, TW), then it takes five turns to load 1 ton of ammunition. For a 'Mech to be available for this rearming, it must have one of the following: a working hand actuator on an arm where all actuators are active (meaning no actuator in the arm has taken a critical hit), a working lift hoist or a working salvage arm.
- If loading a unit when the loader unit cannot be in the same hex, it must be in the rear arc of any unit it is loading.
- The unit being loaded, as well as any units helping to load, are all considered immobile targets during the entire reloading process; all attacks against these units apply a -4 to-hit modifier.
- Any hit against the unit being loaded on any rear location (including aft for grounded fighters) during the Weapon or Physical Attack phases inflicts normal damage, but it also causes all ammunition in the target unit that can to explode. Apply the damage to the unit being loaded as though it were a standard ammunition explosion. In addition, divide the Damage Value of the explosion by 10 (round down) and apply as an area-effect weapon in the target hex; no damage is applied to adjacent hexes, even if there are adjacent units loading.
- Only grounded fighters can be rearmed this way; no other aerospace units may be loaded during a scenario using these rules (see *Rearming Aerospace Units*, p. 214, for rules concerning rearming aerospace units).
- Mobile Structures and Large Naval Vessel Support Vehicles use the rules for Rearming Aerospace Units (see p. 214).
- Rearming a unit submerged in a water hex (or in a vacuum) cannot be done using these rules.

INTRODUCTION

ADVANCED  
GROUND MOVEMENT

ADVANCED  
COMBAT

ADVANCED  
BUILDINGS

ADVANCED  
SUPPORT  
VEHICLES

GENERAL  
RULES

ADVANCED  
SUPPORT VEHICLE  
CONSTRUCTION

ADVANCED  
WEAPONS  
AND EQUIPMENT

INDEX

RECORD SHEETS



- If any of the following Planetary Conditions are in effect, add two additional turns (these are not cumulative): Zero-G, Low-G (more than .2 off Terran standard), High-G (more than .2 off Terran standard), Trace or Very High Pressure Atmosphere, Heavy Snow Fall, Ice Storm, Lightning Storm, Strong Gale, Torrential Downpour, Blizzard, Storm, Tornado, Moonless Night, Solar Flare or Pitch Black.
- Any battle armor weapons that track ammo in a game can be rearmed using these rules. After the required three turns, a single battle armor squad is completely rearmed (regardless of how many different types of ammo-tracking weapons the squad mounts).

### Rearming Aerospace Units

Most Large Craft carry additional stores of ammunition for their weapons and for the Small Craft they transport. Rearming during combat is a difficult and dangerous procedure, but one that many crews and pilots must carry out to prevail. Large Craft may rearm from ammunition stored in their cargo bays. Fighters may rearm by landing on a friendly carrier (Large Craft with fighter/Small Craft bays; see *Launching/Recovering Small Craft*, p. 84, *TW*; or a unit mounting a flight deck (see *Flight Deck*, p. 312)) or airfield (see *Landing and Liftoff*, p. 87, *TW*) that has appropriate ammo stores. Rearming a unit uses the same rules, irrespective of unit type. Any number of tons of ammunition may be reloaded in a single attempt. However, the more types of ammunition being moved and the more tons of each type, the greater the chance of a delay or mishap.

Each loading attempt requires 10 space turns (10 minutes; see *Scale*, p. 76, *TW*). At the start of a Movement Phase (Aerospace), before any movement occurs, a controlling player wishing to rearm announces his intention to do so and immediately rolls 2D6 to determine the success or failure of the operation, as described below. Regardless of the roll result, 10 space turns must elapse before the ammunition is available. If the roll is successful, the ammunition is not available for use until the Weapon Attack Phase of Space Turn 11, following the roll. If the roll is a failure, it requires 10 space turns for the crew to clear whatever mishap occurred, after which point the controlling player can attempt to rearm once more.

Roll 2D6 for each ammunition type being moved (SRM, LRM, AC, RAC, NAC and so on), adding 1 to the result for every ton of that type of ammunition beyond the first. On a result of 1 through 7, the reloading is successful and that ammunition is available to the weapon (assuming sufficient space exists in the weapon's magazine—for example, a fighter designed to carry 2 tons of LRM ammo can't be "rearmed" with ammo that would increase the amount carried to more than 2 tons). On a result of 8 through 11, the reloading attempt fails but the ammo remains available for future reloading.

On a modified dice roll result of 12 or greater, an accident occurs and (except in the case of Gauss and Plasma weapons) the ammunition being moved explodes, damaging the unit. The amount of damage caused depends on the type and quantity of ammunition being moved. To determine the base damage, multiply the tonnage of ammunition being reloaded by the number of shots per ton and the Damage Value (not the Attack Value) per shot; a ton of LRM ammo inflicts 120 points of standard-scale damage (the number of missiles it contains), while five tons of AC/5 ammo cause a total of 500 points of standard-scale damage (5 points per

shot, 20 shots per ton). If an accident occurs, no other reloading attempts may be made on the Large Craft for at least 10 minutes.

On fighters, Small Craft and DropShips, total this damage, then divide the result by 100 (rounding up). Reduce the unit's SI by this amount. Where the accident relates to a fighter or Small Craft being reloaded, the carrier unit also suffers damage equal to one-fifth (round up) of that inflicted and the Small Craft bay is rendered unusable until repaired.

Rearming that takes place outside of combat automatically succeeds and has no chance of an accident occurring. However, in such cases it takes 10 space turns (10 minutes; see *Scale*, p. 76, *TW*) to load each ton of ammo.

**Gauss and Plasma Weapons:** Gauss and Plasma ammunition is inert and so cannot accidentally explode. Players should still make checks when loading such ammunition, as an "accident" result prevents other reloading attempts for 10 space minutes.

## ROLLING MAPS

Standard-rules *BattleTech* usually operates under the condition of a set playing area; a number of maps determined either by a scenario or the players before play begins. A magic line wraps this playing area and if a unit leaves this region, it is immediately out of the game. This is done for simplicity, but also to help facilitate such things as the off-map movement commander ability (see p. 192), withdrawals (see *Forced Withdrawal*, p. 258, *TW*) and so on.

However, such a situation is far from realistic, as battles can often turn into running clashes across vast expanses. More importantly, some situations, such as the use of artillery not directly on the playing area, mean that such artillery units are immune from direct counter-attacks. Using rolling maps means that if artillery starts to fall, the opposing player can attempt to send units to directly attack said artillery units (see *Artillery and Rolling Maps*, p. 179).

Players wishing to add more realism to their games can use the Rolling Maps rules. The very nature of these rules will require players to have a large area of play to allow for any number of maps to be placed. Just as important, this rule assumes that players have access to a large selection of mapsheets to allow for the creation of such large, ever-changing playing areas.

Any time a unit enters a half-hex of the playing area (whether through deliberate movement, displacement and so on), a new mapsheet is placed. The mapsheet must adhere to the standard rules for mapsheet placement (see *Laying Out Mapsheets*, p. 264, *TW*), with the long or short end of the new mapsheet matching up to the current mapsheet. How the players choose that mapsheet is completely up to the individual playing group. It can be randomly chosen, or, if players are using the Selecting Mapsheets method (see p. 262, *TW*), they can use the same table to determine the new mapsheet; for example, if a unit on an Open Terrain #1 mapsheet enters a half-hex, the controlling player would roll on Table 1: Flatlands Terrain (see p. 263, *TW*) to determine the new mapsheet.

To conserve space (since this can quickly turn into a very large playing area), after a new map is placed, if there are any other edge maps that are not currently occupied, the players can choose to remove a mapsheet. Note which mapsheet is removed; the same mapsheet should be replaced if a unit moves into that region again.



## MOVEMENT RECORD

Turn # \_\_\_\_\_ Side: \_\_\_\_\_

Unit ID	Starting Hex	Starting Facing	Movement	Ending Hex	Ending Facing	Torso Facing	# Hexes Moved
Ralph's Locust	1406	4	Run / R / F4 / L / F3	1011	4	5	7

### • MOVEMENT RECORD SHEET SAMPLE •

If rolling maps are used, players will need to determine how to deal with the rules that rely on a specific edge to the playing area. For example, the off-map movement commander ability (see p. 179) may not be used. Similarly, if using the Forced Withdrawal rules (see p. 258, *TW*), then a unit must be at least seventeen hexes (one mapsheet) away from any opposing units when it enters its "home edge" half-hex, after which a new map is not added, but instead the unit is allowed to retreat from the playing area. All such decisions should be made before play begins.

**Aerospace Units:** If airborne aerospace units are in use, anytime such a unit is over a mapsheet not on the playing area (whether using Low Altitude Movement or *Aerospace Units Directly on Ground Mapsheets* rules), the players should determine which ground mapsheet the aerospace unit "spots." When a non-aerospace unit then enters that area—or an aerospace unit lands in that area—that mapsheet(s) should be placed.

## SIMULTANEOUS MOVEMENT

In place of standard movement, players can use the following alternate movement system. While it better reflects the reality of simultaneous combat, it requires more record-keeping, as well as a gamemaster to help track movement and resolve various actions, as noted below.

### PLOTTING MOVEMENT

Instead of alternating movement back and forth, and moving units singly on the playing area, all players first plot their units' movements on a copy of the double-blind movement chart at the back of this rulebook, using the following guidelines.

List the unit's movement mode, if applicable (Walking/Cruising/Thrust, Running/Flanking/Maximum Thrust, Jumping, VTOL, UMU and so on). Then record the unit's movement for the turn, using the following designations (these do not include all the advanced movement options open to a player, but can be used as a base line for players to determine their own codes for all the optional rules found in this rulebook):

- F x = Move forward x number of hexes
- R x = Turn right (x hex facing, no number means 1 hexside)
- L x = Turn left (x hex facing, no number means 1 hexside)
- J = Jump
- SU = Stand Up
- SL = Sidestep left (four-legged or jumping 'Mechs only)
- SR = Sidestep right (four-legged or jumping 'Mechs only)
- B x = Move backward x number of hexes
- TL = Turn left (free movement for a jumping 'Mech)
- TR = Turn right (free movement for a jumping 'Mech)
- L x = Landing x number of hexes (airborne aerospace units)
- T x = Take-off x number of hexes (grounded aerospace units)
- U x = Up x number of level/elevations/depths
- D x = Down x number of level/elevations/depths
- O = Opportunity fire (see p. 86)

Note the starting and ending hex numbers for each unit, the number of hexes moved and the direction that the unit's torso or turret is facing using the Scatter Diagram (see p. 182).

**Time Limit:** The gamemaster may wish to impose a time limit for how long players have to plot their movement. If a player does not turn in his plotted movement for a unit before the time expires, that unit is considered not to have moved.

*Ralph's Locust occupies Hex 1406, facing Direction 4. During the Movement Phase, Ralph has the 'Mech run. He turns the 'Mech right 1 hex facing, moves it forward 4 hexes, turns it left 1 hex facing, and moves it forward 3 hexes. He then elects to twist the torso so that it is facing Direction 5. The 'Mech has moved a total of 7 hexes. The notation for the movement would look like the Movement Record Sheet Sample at the bottom of this page.*

### MOVEMENT

Once all players have plotted their movement, everyone moves his units and records their positions with unit markers on the mapsheets, with all movement occurring simultaneously. In cases where two or more enemy units would violate the hex stacking limits, the side that won the Initiative occupies the contested hex (see *Stacking*, p. 216).

Once the players have moved all their units, each gives his movement chart to the gamemaster. The gamemaster then moves the units on his mapsheets, first moving all the units of the side that won the Initiative.

The gamemaster resolves all Piloting Skill Rolls for skids and sideslips. The players resolve all other movement- or non-movement related Piloting Skill Rolls.

INTRODUCTION

ADVANCED  
GROUND MOVEMENTADVANCED  
COMBATADVANCED  
BUILDINGSADVANCED  
SUPPORT  
VEHICLESGENERAL  
RULESADVANCED  
SUPPORT VEHICLE  
CONSTRUCTIONADVANCED  
WEAPONS  
AND EQUIPMENT

INDEX

RECORD SHEETS



## Stacking

Because movement occurs simultaneously, several units may occupy a single hex at the end of a Movement Phase. Whenever the number of such units exceeds the stacking limit for the hex (see p. 57, *TW*), both players automatically roll Initiative, with the winning player occupying the hex. The enemy unit(s) end their movement in the hex they would have occupied prior to entering the contested hex. Units involved (provided they are not specifically prohibited from doing so) may have the chance to charge their opponents during the Physical Attack Phase of the turn (see below).

**Physical Attacks:** Any physical attack that requires a unit to have already moved in order to declare such an attack cannot be made under the Simultaneous Movement rules, unless two units will violate the stacking rules, as noted above. The player that wins the Initiative can either occupy the hex or force the other player to occupy it and can immediately announce such a physical attack (Charging, Death From Above and so on), provided the unit could normally make such an attack. All such attacks are resolved per standard rules.

---

# TAKING CONTROL OF A UNIT

---

During a battle, two opportunities for taking control of a unit may arise: when a unit is abandoned, and during a swarming attack.

**Electronic Equipment:** As noted under *Ejection and Abandoning Units* (see p. 196), electronics on a unit where the pilot/crew have ejected/abandoned the unit continue to function until the unit is destroyed. For ease of play, as soon as a unit has been taken control of, all electronic equipment on the unit operates only for the side that now controls the unit. This includes such equipment as a C<sup>3</sup>, which would stop working for the enemy and, provided the new controlling player has a C<sup>3</sup> network and can plug the unit into that network without violating the C<sup>3</sup> network rules (see p. C<sup>3</sup> Computers, p. 131, *TW*), the C<sup>3</sup> would be immediately usable.

**Large Craft and Large Naval Vessel Support Vehicles:** Large Craft or Large Naval Vessel Support Vehicles follow their own rules for taking control of a vessel that is not abandoned, in which case a boarding action takes place (see pp. 199 and 200, respectively).

## ABANDONED UNITS

In standard-rules play, if a unit is abandoned—say, due to the crew being killed—the unit is usually considered destroyed. Under these rules, a unit is not considered destroyed in such cases. Instead, it becomes a “neutral” unit and so all players’ units can move into and out of the hex it occupies until the unit is taken control of by a player once more. Stacking limits still apply, with such abandoned units considered a “third neutral player;” for example, an abandoned ‘Mech could still be the only ‘Mech in the hex.

If a unit is abandoned but not destroyed—the pilot/crew was killed, the crew voluntarily abandoned the vehicle, and so on, as described above—a controlling player (regardless of which side) has a chance to take control of that unit. The exception are ‘Mechs/fighters where the pilot has actually ejected; as the command couch is no longer in the cockpit, the ‘Mech/fighter cannot be piloted until the unit is repaired.

First, the appropriate pilot/crew for the unit in question must be available. A MechWarrior must be used to pilot a ‘Mech, a

vehicle crew to pilot a vehicle and so on (if the pilot/crew have taken damage at a previous point, that damage still applies and the applicable modifiers must be taken into consideration with the new unit). During the End Phase of any turn in which an appropriate pilot/crew are located in an abandoned unit’s hex, the controlling player announces he will attempt to take control of the unit. The pilot/crew may not take any other action for the next turn. During the End Phase of the following turn (provided the pilot/crew is still alive and in the hex), the pilot/crew automatically takes control of the unit in question regardless of whether the unit is friend or foe.

The only exceptions are enemy ‘Mechs and aerospace fighters, which are heavily coded against such a hack of their systems. During the End Phase after a pilot has been in the hex for a turn, the pilot’s controlling player rolls 2D6. On a result of 2-11, the pilot has been unable to hack the system; provided he stays in the hex another turn, he can once again attempt to hack in (there is no limit to the number of times a pilot can try to hack an abandoned ‘Mech or fighter). On a result of 12, the pilot has hacked the system. The ‘Mech or aerospace fighter is now under the control of the new player and it may move and attack normally on the following turn. However, for ‘Mechs, apply a +2 modifier to all Piloting Skill Rolls and all attacks to reflect the difficulty of piloting a machine that has not had its neurohelmet synched with the pilot’s specific brain wave pattern.

As soon as a MechWarrior enters the hex of an abandoned ‘Mech, he or she is considered in the cockpit for any type of weapons damage inflicted against the abandoned unit (if the ‘Mech falls for any reason in this situation, the pilot automatically takes 1 point of damage).

The above rules represent a pilot taking extreme care when attempting to take control of a ‘Mech or aerospace fighter to avoid a nasty feedback shock as the safety systems attempt to protect the unit. A player can choose to lower the necessary number from 12 to anything between 9 and 12 to hack into the unit, but must announce his intention to do so before making the roll. Each point below 12 applies a cumulative point of damage to the pilot in the case of a failed roll. For example a failed roll against a target number of 9 would apply 3 points of damage to the hacking pilot.

**Infantry:** For any unit except ‘Mechs and aerospace fighters, conventional infantry can be turned into the pilot/crew, applying a +2 modifier to all Driving Skill Rolls, as well as a +1 to-hit modifier to all weapon attacks. If the infantry in question have an Anti-‘Mech Skill Rating of 5 or less, only apply a +1 Driving Skill modifier.

Motorized and mechanized conventional infantry, as well as battle armor (except exoskeletons and PA(L) battle armor, which can be used), cannot be used in this fashion.

If using Vehicle Crews (see p. 218), and the number of infantry in the unit taking control is less than the number of crewmen required for a given vehicle tonnage, apply an additional +1 Driving Skill modifier for each trooper less than the minimum requirement. For example, an infantry platoon that lacks anti-‘Mech-training with only 5 troopers left is taking control of a 100-ton vehicle, which normally would require a crew of 7. In addition to the standard +2 Driving Skill and +1 to-hit modifiers for the infantry taking control of a vehicle, an additional +2 Driving Skill modifier would be applied (as well as limiting the number of attacks that can be made against multiple targets). If the infantry were anti-‘Mech trained, the total modifiers involved would only be a +3 Driving Skill modifier.



For Large Naval Vessel Support Vehicles and Large Craft, the infantry can only take control if they can reach sufficient numbers to make up the large number of crew required for such units (this may require multiple infantry platoons). First, determine the minimum crew requirements of the unit in question (using the Technical Readout write-up, the record sheet or the appropriate construction rules). Once the minimum crew number is determined, divide the number of infantry attempting to take control of the unit by that value. Once that percentage is known, compare it to the Crew Casualties Table (see p. 206) to determine the modifiers under which the infantry will operate; if the percentage is less than 5, the unit cannot be taken control of (though the infantry can stay in the hex waiting for additional infantry to arrive to boost the crew percentage high enough). In addition, a flat +1 modifier is applied to reflect that the infantry are not intimately familiar with the craft; if the infantry have an Anti-'Mech Skill Rating of 5 or less, ignore that additional +1 modifier.

For such large units, bay personnel are not counted when determining the minimum crew requirements. However, infantry can board such an abandoned unit and attempt to take over control of both the carrying unit and the units being carried, or just the units being carried, as described above; such carried units would be able to dismount the carrier unit, following all standard rules, in the following turn.

In all instances, if there are troopers left over (for example, a full platoon of 28 taking control of a vehicle that only requires 2 crewmen to pilot), the controlling player can simply subtract those troopers from the platoon.

**Elite Anti-'Mech-Trained Infantry:** If players are fielding infantry that fall into the categories described above for an infantry unit taking control of another unit, and they have a Anti-'Mech Skill Rating of 1, they can be used to pilot 'Mechs and aerospace fighters. In this case, apply a +1 to-hit modifier in addition to the standard +2 Piloting Skill modifier.

## SWARMING

If an infantry unit has successfully swarmed an enemy unit, it may attempt to kill the crew with as little damage as possible to the unit, leaving it open for use by that infantry's side (an extremely difficult and rare feat of infantry prowess).

Before the controlling player of a swarming unit rolls on the Swarm Attacks Hit Location Table (see p. 222, *TW*), that player may announce he is attempting to eliminate the pilot/crew while limiting damage. In this instance, the infantry forgoes its full damage and rolls on the Swarm Attacks Hit Location Table (or the appropriate hit location table if the target is a non-'Mech unit). Only a single point of damage is applied to the rolled location. If the location rolled is the head (rear for vehicles), the controlling player immediately rolls 2D6. On a result of 10+, the swarming unit has successfully breached the cockpit and killed the pilot without damaging the 'Mech or vehicle any further; the unit powers down (a 'Mech will not automatically fall, though it does so if a Piloting Skill Roll is required before another pilot takes control) and is considered abandoned. Another MechWarrior or vehicle crew can then take control of it as described above.

## TRANSPORT BAYS (EXPANDED)

During standard-rules play, units in transport bays (see p. 239, *TM*)—such as on DropShips or Large Naval Vessels—can dismount at any time (see *Carrying Units*, p. 89, *TW*), entering the scenario as soon as their carrying unit is in a position to allow for legal dismounting. However, this simplicity ignores the reality that such units can be in varying states of readiness, from operational to completely shut down, especially during long voyages or when conflict is not expected. That readiness will determine how quickly such units can be activated, dismounted and put into action.



ES/IRH

Swarming battle armor attempt to wrest control of a Fortieth Shadow Division Zeus away from its pilot.

INTRODUCTION

ADVANCED  
GROUND MOVEMENT

ADVANCED  
COMBAT

ADVANCED  
BUILDINGS

ADVANCED  
SUPPORT  
VEHICLES

GENERAL  
RULES

ADVANCED  
SUPPORT VEHICLE  
CONSTRUCTION

ADVANCED  
WEAPONS  
AND EQUIPMENT

INDEX

RECORD SHEETS



## TRANSPORT BAYS STATUS TABLE

1D6 Roll	Status	Turns To Activation**
1-2	Shutdown	4
3-4	Stand By/Empty	3
5	Stand By/Occupied	2
6	Operational*	1

\*Conventional Infantry are always considered "operational."

\*\*This is in ground turns; if using space turns, all units are considered "activated" after a single space turn, regardless of the units' status or the availability of technicians (though the lack of a technician still applies the +2 modifier to the Piloting Skill Roll to determine if a shut-down unit activated properly [see *Bay Personnel*, p. 202]).

At the start of a scenario, the controlling player of any occupied transport bays should write down the status of the units in each bay, as shown on the Status column of the Transport Bays Status Table (note that such transport bays can be on another unit—such as a Large Naval Vessel, Large Craft, or Mobile Structure—or in a building). The players should agree on a formula for determining the various status levels. For example, if conflict is imminent and the purpose of the carrying unit is to disembark carried units onto the battlefield, having all units operational might be appropriate. However, if conflict is not expected and an attack surprises a carrying unit, then a good majority of the carried units would either be at Shutdown or at least in Stand By/Empty status. If players wish, they may simply use the 1D6 Roll column of the table to quickly and randomly determine the status of the various units in transport bays prior to game play (such randomness can help to reflect the reality of different status checks, routine maintenance and so on that would occur at different times for various units in transport bays, particularly on large vessels with many such cubicles).

At the start of any turn, the controlling player may activate any number of units. The number of turns in which the activating unit may take no actions before it is fully active is shown on the Turns to Activation column of the Transport Bays Status Table. For example, at the start of Turn 2 a player nominates an Operational 'Mech, a Stand By/Occupied battle armor squad and a Stand By/Empty Vehicle. Nothing happens during Turn 2 for any of those units. At the start of Turn 3, the 'Mech becomes active and can dismount during the Movement Phase (provided there is a legal hex), or can be used against boarding non-infantry units during the Weapon and Physical Attack phases; no MP are spent, the unit simply makes attacks (see *Boarding Actions (Non-Infantry)*, p. 188). At the start of Turn 4, the battle armor unit is active and can either dismount during the Physical Attack Phase or can be used against boarding non-infantry units during the Weapon and Physical Attack phases, or can be used to defend the carrying unit or building against an infantry action (see *Infantry Vs. Infantry Actions*, p. 199). At the start of Turn 5, finally the vehicle is active and can follow the 'Mech's actions, either dismounting (provided there is a legal hex) or staying on board to fight against boarded units.

At the start of a turn when a non-infantry unit that began a scenario shut down is fully active, the player makes a Piloting/Driving Skill Roll, applying no modifiers. If the roll succeeds, nothing happens. If the roll fails, the unit's computer didn't start properly due to the speed of start-up; apply a +1 modifier to all Piloting/Driving Skill Rolls and all weapon and physical attacks for the following 3 turns. After the 3 turns, the computer resets properly and the modifier is eliminated.

**Bay Personnel:** If a technician for the type of unit ('Mech technician, vehicle technician and so on) is unavailable (see *Bay Personnel*, p. 202), either due to a previous injury, because the unit is involved in the defense of the carrying unit or building (see *Infantry Vs. Infantry Actions*, p. 199), or for some other reason, all units except those at Operational status require 1 additional turn to reach full activation. In addition, apply a +2 modifier to the Piloting/Driving Skill Roll to determine whether a Shutdown unit activates properly (see above).

**Pilots/Crews:** If pilots/crews are to be involved in defending the carrying unit or building against infantry (see *Infantry Vs. Infantry Actions*, p. 199), the player should note the specific units whose pilots/crews are being used in such actions. Those pilots/crews are not available for activating units under these rules until they are removed from such defensive actions. Additionally, any infantry in transport bays that the controlling player has assigned to defending against infantry combat cannot be activated until they are removed from such actions.

**Hot Zone:** As with dismounting and mounting from a DropShip, these rules approximate the activation of a unit within the "hot zone" of a scenario: fast and furious, weapons blazing. Outside of a scenario (that is, outside of direct combat), the safe start-up of a unit will be done across time, under the restrictions noted above.

## VEHICLE CREWS

Unlike 'Mechs, which are piloted by a single MechWarrior, all but the smallest vehicles are controlled by a crew of two or more. Many factors determine the number of crewmen a vehicle requires, the most important factor being the number of weapon systems the vehicle mounts. For purposes of game play, however, the number of crewmen relates directly to the size of the vehicle.

To determine the number of crewmen, divide the tonnage of the vehicle by 15, rounding fractions up. The size of a vehicle's crew is rarely important in a single game, but frequently becomes important in campaign play.

### CREW NUMBERS AND ABILITIES

Depending on the number of crew it carries, a vehicle may operate under certain restrictions or advantages, as described below.

#### Single Crewman

Small vehicles (15 tons and lighter) have only one crewman, who must act as the driver, gunner and commander. Such a vehicle may not attack more than a single target each turn. Also, if any of the vehicle's weapons or turrets jam, the vehicle may neither move or fire while clearing the jam.

#### Two Crewmen

Vehicles with two crewmen (16–30 tons) usually have one driver and one commander/gunner. Such vehicles operate normally.



### Multiple Crewmen

Large vehicles (31 tons and heavier) have three or more crewmen, some of whom act as loaders or additional gunners to allow the vehicle to attack multiple targets more easily. For every crewman above two, a vehicle may attack an additional target without suffering the secondary-target modifier.

These additional targets may fall outside the front firing arc. For example, a 50-ton Maxim hovercraft has a crew of four ( $50 \div 15 = 3.33$ , rounded up to 4). Its two extra crewmen allow it to fire at up to three targets in the same Weapon Attack Phase without penalty. The standard +1 secondary-target modifier would apply to all targets past 3.

## ZIP LINES

Conventional Infantry (either foot or jump) and battle armor can dismount from an airborne VTOL using zip lines (instead of using Jumping MP). All the standard rules for infantry with Jumping MP dismounting from a VTOL apply (see p. 225, *TW*), except that each infantry unit dismounting in this fashion must make an Anti-Mech Skill Roll, adding any applicable modifiers from the Ejecting Modifiers Table (see p. 197). A failure results in a single 5-point Damage Value grouping applied to the unit; against conventional infantry the damage is applied as though the attack originated from another infantry unit.

**Airships:** Infantry can also dismount from Airships in this fashion, but the Airship must be at Altitude 1 (NOE).

## CONCEALING INFORMATION

In large-scale battles, accurately assessing the condition and strength of an opponent's forces can be quite difficult. These optional rules for concealing certain information from the opposing player simulate the challenges of gathering accurate battlefield intelligence. The system works quite simply—each player conceals most of the information on his record sheets from his opponent until one of the opponent's units manages to obtain the information by visually or electronically determining the configuration and condition of the player's units.

We strongly recommend that these rules be used only in games presided over by an impartial referee. The rules for concealing information allow ample opportunity for cheating and may lead to long, potentially bitter arguments.

Note that these rules differ from the detection rules associated with double-blind play (see p. 220).

### RECORD SHEETS AND SET-UP

Each player should conceal his unit's record sheets from his opponent before and during game play. Keeping record sheets on a clipboard with a folding cover is a simple and convenient way to accomplish this.

Before play begins, each player should make sure that each unit's record sheet includes appropriate notations for unit features such as auto-eject status, special ammunition loads, Piloting/Gunnery Skill ratings and so on.

### AVAILABLE INFORMATION

Any unit that is not deployed under the Hidden Units rules is visible to an opponent as soon as game play starts.

Consequently, each player can see the location and general type of every opposing unit. For example, an enemy will recognize a CPLT-C1 *Catapult* as a *Catapult*, but he will not know that it is the CPLT-C1 model. Similarly, an opponent will recognize the general type of an infantry unit—foot, motorized, jump, mechanized or battle armor—but not the type of armament the unit carries.

To obtain further information about an opposing unit, a player must have one of his own units examine the opposing unit by successfully scanning it with an active probe or standard sensors, or by visually inspecting it during play.

### SCANNING

Active-probe scanning provides the most detailed and accurate information about enemy units. However, when such sensors are unavailable, standard 'Mech or vehicle sensors or a simple visual inspection can reveal a certain amount of information.

#### Active Sensors

Any unit that has active sensors (is not shut down, its sensors are not destroyed and so on) can always tell the following basic information without any scanning required.

**Armor Condition:** How much armor is left in a given location. The sensor readings follow a color code, based on the percentage of armor left compared to its standard undamaged condition: 100-90 percent = green; 90-50 percent = yellow; 50-10 percent = red; 10-0 percent = black. For example, a player is facing a *Centurion* that took damage from a medium laser hit to its right arm. When the player asks his opponent what the *Centurion's* status is, the opponent responds that all locations are green except for the right arm, which is yellow [ $16$  (original armor value) -  $5$  (damage) =  $11$  /  $16$  (original armor value) =  $.68$ , or 68 percent (yellow)].

**Heat Condition:** The unit's current heat level. Once again, the sensors follow a color code: 1-7 = blue; 11-14 = green; 15-21 = yellow; 22+ = red.

#### Active Probes

Any time a unit enters the range of any type of active probe operated by an opponent, the player must reveal that unit's record sheet to the opponent. The player must leave the sheet face up and available for the opponent to examine as long as the unit remains within the probe's effect radius.

Any unit mounting an ECM suite can potentially defeat an active probe on a 2D6 dice roll against a Target Number of 8. If the roll fails, the unit must reveal its information.

#### Standard Sensors

Any 'Mech, vehicle, battle armor or aerospace unit can use its standard sensors (radar, magscan, IR and so on) to examine one target (a Large Craft can scan up to four targets) within its line of sight; aerospace units must be grounded, or on the playing area if using the Aerospace Units on Ground Mapsheets rules (see p. 91, *TW*), or in the hex corresponding to the ground mapsheet if using Low-Altitude Movement (see p. 80, *TW*) to make a sensor scan. Units may make only one scan per

INTRODUCTION

ADVANCED  
GROUND MOVEMENT

ADVANCED  
COMBAT

ADVANCED  
BUILDINGS

ADVANCED  
SUPPORT  
VEHICLES

GENERAL  
RULES

ADVANCED  
SUPPORT VEHICLE  
CONSTRUCTION

ADVANCED  
WEAPONS  
AND EQUIPMENT

INDEX

RECORD SHEETS



turn, during the End Phase. If a unit's sensors are critically hit, the sensors cannot perform this function.

To scan a target with standard sensors, the scanning unit's controlling player must nominate the target and announce that he is scanning it. The scanning player may ask one question about the target unit, such as how much armor it has in a specific location, its specific model number, the amount of ammunition remaining for a particular weapon or its movement abilities. The target unit's controlling player must answer this question truthfully.

Scanning questions must be easily answerable. Any question that requires the target player to perform lengthy calculations—such as “How much armor is left on your entire ‘Mech?”—is prohibited. Scanning players should also be careful about asking questions that require the target player's opinion, such as, “What's the status on your Gauss rifle?” Target players may interpret such questions as they see fit.

If the target unit is within range of friendly ECM, the target player can force the scanning player to make a 2D6 roll to defeat the ECM before he asks his question. In this case, the scanning player must achieve an 8 or higher on the roll. If the roll fails, no information is revealed. Forcing the scanning player to make this roll, however, reveals the presence of ECM in the area. Rather than revealing that information, the target player may simply choose to let his opponent ask a question based on his unit's sensors.

### Visual Inspection

Visually inspecting a unit is the last-ditch way to obtain information about the enemy. Any type of unit, including infantry and units with damaged sensors, can use visual inspection.

Visual inspection works just like standard sensor scanning, with a few exceptions. First, units can visually inspect only targets within three hexes of their position. Second, visual inspection cannot provide information that could not be determined by looking at the outside of a target

Finally, ECM has no effect on visual inspection.

---

## DOUBLE-BLIND RULES

---

In a double-blind game, neither player can “see” the other's forces until they enter the sensor or visual range of the opponent's units. In this way, double-blind rules inject the uncertainty of real battle into *BattleTech* and force players to anticipate their opponent's movements, much like real battlefield commanders.

The double-blind format requires a minimum of three players, one of whom acts as gamemaster. The gamemaster monitors the status and movement of the two opposing players' forces, informs the players of their spotting sweep results and ensures the smooth play of the game.

Three identical mapsheets and 'Mech sets are needed for a double-blind game—one for each player and one for the gamemaster. Each player uses his maps to record the movement of his own units and any enemy forces his units have detected. The gamemaster uses his mapsheets to record the movement of both sides. Additionally, each player records the movement of his forces on a copy of the double-blind movement chart found at the back of this book.

**Hidden Units:** Units that start a double-blind game using the Hidden Units rules (see p. 259, *TW*) cannot be spotted except by the methods outlined in the standard game rules. If a hidden unit fires, it is spotted only if an enemy unit could have seen it under the visual spotting rules.

**Running a Game:** To help increase the fun of a double-blind game, during the Weapon and Physical Attack phases the gamemaster can place the units that can be seen by both sides on the playing area of the main table; this allows players to interact and increase excitement as they resolve various attacks. However, this assumes that the area in which play is occurring allows for the main table to be removed some distance from the other two tables.

**Note:** In a double-blind game, specific rules contradict how equipment (such as the range of ECM and probes) and some situations (determining LOS) are used in standard and advanced-rules game play. These changes enhance the “fog of war” aspects of a double-blind game and increase everyone's enjoyment of this more realistic game play. Any rules in this section are only for use in double-blind games and should never be used in regular games.

### Simultaneous Movement

Double-blind rules can be time intensive, and so players may wish to use simultaneous movement (see p. 215) or some other time-saving techniques (such as a computer for dice rolling or tracking movement) to help speed up play.

If simultaneous movement is used with a double blind-game, use the following sequence of play instead of the standard double-blind sequence of play.

1. Initiative Phase
2. Movement Phase
3. Spotting Phase
  - Torso and Turret Twist
4. Weapon Attack Phase
  - Standard Weapons Fire
5. Physical Attack Phase
6. Heat Phase
7. End Phase

### Double-Blind Play on the Space Map

While these rules are specifically designed for play on ground mapsheets, players can easily adapt them for use on a space map, taking into consideration the unique aspects of such games.

### SEQUENCE OF PLAY

Double-blind games use the following modified *BattleTech* sequence of play.

1. Initiative Phase
2. Movement Phase
  - Spotting Phase
3. Weapon Attack Phase
  - Standard Weapons Fire
4. Physical Attack Phase
5. Heat Phase
6. End Phase



## VISUAL RANGE TABLES

Light/Weather Condition	Maximum Visual Range (in hexes)			
	Ground BattleMech/Vehicle*	Infantry	Aerospace†	Large Craft
Pitch Black**	3	1	5	4
Moonless**/Full Moon Night**/Blizzard	5	2	10	8
Heavy Fog/Hail/Rainfall/Snowfall/Sleet/ Blowing Sand	10	5	20	15
Dusk/Dawn**/Snow Flurries/Gusting Rain	15	8	30	20
Moderate Rainfall/Snowfall	20	10	50	25
Light Fog/Hail/Rainfall/Snowfall	30	15	60	35
Daylight (no conditions)	60	30	120	70

Additional Effects	Modifier
Light Smoke	-1 hex per hex in LOS
Heavy Smoke	-2 hex per hex in LOS
Active Visual Camouflage‡	Half distance, round down§
Void-Signature System	Quarter distance, round down§
Searchlight	Changes Nighttime Conditions to 30 hexes

\*Includes grounded aerospace units (but not Large Craft)  
 \*\*If a unit mounts a searchlight, add 10 hexes; for infantry, add 5 hexes.  
 †Must be between Altitude 2 and 9; if at Altitude 1 (NOE), the unit is considered grounded. If at Altitude 10 or higher, the unit cannot be used for visual spotting.  
 ‡This includes the following: Chameleon Light Polarization Shield, Mimetic Armor, Sneak/Camo and Battle Armor Camo (the Void-Signature System is also considered an active visual camouflage, though its rules are different; at left)

§The standard visual spotting distance of a unit under a given situation is half, rounded down (or quarter distance, rounded down if using the Void-Signature System active visual camouflage). For example, a BattleMech in daylight would only have a visual spotting range of 30 when trying to visually spot a unit mounting an active visual camouflage (or 15 when trying to visually spot a unit mounting the Void-Signature System).

The Initiative, Heat and End phases of each turn in the double-blind game follow standard *BattleTech* rules except where noted. Special double-blind rules for the Movement Phase, Weapon Attack Phase and Physical Attack Phase are described in detail below.

### INITIATIVE PHASE

During the Initiative Phase, each unit must declare to the gamemaster what sensor system it is using (Radar, IR, Magscan, Seismic and so on) for that turn. The players can write this information down and pass it to the gamemaster, or whatever system the players determine works best.

### MOVEMENT PHASE (SPOTTING PHASE)

After each unit moves, the gamemaster decides if the unit is now visible to any opposing units.

First, the gamemaster determines if the moved unit can be detected visually by any enemy unit.

Second, the gamemaster checks to see if the unit can be detected by any enemy unit's sensors.

If the unit is visible, place it on the map. Note that while it may be visible, it may not be able to see the unit that spotted it; if so, the moved unit does not know it has been spotted.

### Visual Spotting

A unit visually detects an enemy unit whenever two conditions are met. First, the spotter must have a clear line of sight to the enemy unit. Second, the enemy unit must be within the visual range of the spotting unit. Use the Visual Range Table to determine maximum visual range under various atmospheric conditions.

Note that the combinations of various Planetary Conditions are numerous, such as Heavy Snow Fall with Dawn/Dusk. In such situations, players should only use the most restrictive condition.

Except for a vehicle with a single crewman—which can only spot in its forward arc—all units have a 360-degree visual arc; 'Mechs have a 360-degree view compressed into the forward view screen. Vehicles with more than one crewmember can spot in multiple firing arcs (see *Vehicle Crews*, p. 218). Each additional crewmember beyond the first can spot in one additional firing arc, so that a vehicle with 4 or more crewmembers can spot in a 360-degree arc.

### Sensor Spotting

Electronic sensors cover a wider field than most visual checks, but they can be fooled by the proper counter-measures. As with visual checks, sensors operate in a 360-degree arc, regardless of the spotting unit's firing arc. Unlike visual spotting, however, sensors do not need to have LOS to a target in order to detect it. However, just because your sensors have picked up a target doesn't mean the target is visible. Once a sensor has revealed a unit, standard LOS must be established to the unit before it can be revealed.

With the exception of magscan, sensors will not pass through the surface of a water hex, so a sensor in a location above or below water cannot detect a unit that is below or above water, respectively. The one exception occurs if a sensor is located in the "body" of a naval vessel on the surface (all non-equipment specific sensors are automatically located in the "body"), in which case the sensor can detect units both above and below the surface of the water.

INTRODUCTION

ADVANCED  
GROUND MOVEMENT

ADVANCED  
COMBAT

ADVANCED  
BUILDINGS

ADVANCED  
SUPPORT  
VEHICLES

GENERAL  
RULES

ADVANCED  
SUPPORT VEHICLE  
CONSTRUCTION

ADVANCED  
WEAPONS  
AND EQUIPMENT

INDEX

RECORD SHEETS



## SENSOR RANGE TABLES

Sensor System	Range (in hexes)		
	Short (2D6 = 7–8)	Medium (2D6 = 5–6)	Long (2D6 = 2–4)
Beagle Active Probe*	1–12	13–24	25–36
Bloodhound Active Probe	1–16	17–32	33–48
Clan Active Probe*	1–15	16–30	31–45
Clan Watchdog/Light Active Probe	1–9	10–18	19–27
'Mech IR/Magscan Sensor†	1–10	11–20	21–30
'Mech Radar	1–8	9–16	17–24
Vehicle IR/Magscan Sensor†	1–9	10–18	19–27
Heat Sensor‡	1–9	10–18	19–27
Vehicle Radar/Improved Sensor§	1–6	7–12	13–18
'Mech Seismic Sensor	1–2	3–4	5–6
Vehicle Seismic Sensor	1	2	3

Additional Effects (All Sensors except Seismic)	Modifier
Castles Brian or Hill Hex	If along LOS, all sensors completely blocked
Electromagnetic Interference	–4 to all range brackets
Lightning Storm	–1 to all range brackets

Additional Effects (Radar Only)	Modifier
Building Hex	If along LOS, sensor completely blocked

Additional Effects (IR/Heat Sensor/Radar only)	Modifier
Heavy Woods/Jungle Hex	–1 hex per range bracket per hex in LOS
Ultra Woods/Jungle Hex	–2 hex per range bracket per hex in LOS
Any Building Hex but Hardened or Castles Brians	–1 hex per range bracket per hex in LOS
Hardened Building Hex	–2 hex per range bracket per hex in LOS
Castles Brian Hex	If in LOS, all sensors completely blocked

\*Includes the active probe mounted on battle armor (see p. 228, *TW*)

†An infrared sensor spots a unit that is “hot” more easily than other units (see *Infrared Sensors*, below); a magscan sensor spots larger units more easily (see *Magscan Sensors*, p. 223).

‡As mounted on battle armor (see p. 256, *TM*); is used exactly like a 'Mech/vehicle IR sensor (p. 223)

§As mounted on battle armor (see p. 228, *TW*)

The ranges of various electronic sensor systems appear in the Sensor Range Table, p. 222. To make a Sensor Check, the player rolls 2D6. A result of 7 or 8 means the sensor detects any unit within its short range. A result of 5 or 6 means the sensor detects units out to its medium range. A result of 2 to 4 means the sensor detects units out to its long range. A roll of 9 to 12 means the sensor failed to detect any units. Remember that a spotting unit may use only one type of sensor per turn, which is declared to the gamemaster at the start of the turn (see p. *Initiative Phase*, p. 221).

Vehicles have access to sensor systems similar to those used on 'Mechs, but in most cases these systems have shorter ranges, reflected in the Sensor Range Table. Conventional infantry units do not have access to electronic sensors (see Sensor Range Table, above).

Unless specifically noted otherwise on the Sensor Range Table, no objects (hills, building, trees and so on) block sensors.

**Airborne Units:** Sensor ranges for airborne units do not change, though LOS exists to all units on the playing area. If using a High-Altitude Map, an airborne unit must be in the Ground Hex Row to make a sensor detection roll. If using a Low-Altitude Map, an airborne unit cannot be at Altitude 10; it must be at Altitudes 1–9 to make a sensor detection roll. In both instances, the airborne unit is considered to be in Hex 0909 of the ground mapsheet corresponding to the hex occupied by the unit.

**Seismic Sensors:** A unit must have expended MP (of any type) during the Movement Phase of the turn in which the Sensor Check is made in order to be detected by a seismic sensor (this includes units landing in a hex after expending Jumping MP).

Airborne units (including units expending VTOL MP) and submerged units (provided they are not moving along the bottom of the water hex) cannot use seismic sensors, and they cannot be spotted by seismic sensors.



## ECM/STEALTH MODIFIER TABLE

Spotting Unit's Probe/Sensor	Target Unit's ECM System						
	Void-Signature System	Angel or Null-Signature System	Standard Clan, Watchdog, or Guardian	Stealth Armor* or EW System	Infantry Sneak, ECM	Infantry Sneak†	Active Visual Camouflage‡
Beagle	+6	+5	+4	+3	+3	+2	NA
Bloodhound	+4	+3	+2	+1	+1	+1	+1
Clan Active Probe	+5	+5	+4	+3	+2	+1	NA
Light Active Probe	+6	+6	+5	+4	+3	+2	NA
Watchdog	+6	+5	+4	+3	+2	+1	NA
EW System	+7	+6	+4	+4	+3	+2	NA
'Mech Sensor	+7	+6	+5	+4	+4	+2	+2
Vehicle Sensor/Improved Sensor§	+7	+7	+6	+5	+3	+1	+3
Communications Equipment/Command Console	+7	+7	+6	+5	+5	+3	+3
Seismic/IR/Magscan	NA	NA	NA	NA	NA	NA	NA

\*Includes any armor with the word "stealth" in its title, regardless of what unit mounts it.

†Includes: DEST Infiltration Suit; Sneak, Camo; and Sneak, IR.

‡See "‡" footnote on the Visual Range Table (p. 221).

§As mounted on battle armor (see p. 228, TW)

If using Planetary Conditions, seismic sensors cannot be employed during any turn that an earthquake or meteor shower occurs on the playing area.

**Infrared Sensors:** When using infrared sensors, any time a unit that tracks heat is "hot," it can be more easily detected. For each heat-induced MP modifier on the target, the range of a sensor is expanded for that unit(s) by 1 hex; add 1 additional hex if the unit has been hit by an inferno attack, or is standing in a hex that is on fire. For example, a player is using a 'Mech IR sensor and rolls a 5, resulting in detection of any unit in that sensor's medium range bracket (hexes 11–20). However, a 'Mech with 15 points of heat (inflicting a –3 MP modifier) is at hex range 8, three hexes away from the medium range bracket. The infrared sensor spots the "hot" unit. If the 'Mech only had 14 points of heat, or if it was at hex range 7 (four hexes away from the medium range bracket), it would have remained undetected.

If using Planetary Conditions that affect the temperature of heat-tracking units, also apply the following rules: for each –1 Heat Point applied per turn, the range of a sensor is expanded for that unit(s) by 1 hex; for each +1 Heat Point applied per turn, the range of an IR sensor is shrunk for that unit(s) by 1 hex (as described above).

Units that are not "hot" cannot be detected by an IR sensor scan.

**Magscan Sensors:** If magscan sensors are being used, any unit (except conventional foot and jump infantry) within range is spotted regardless of LOS, unless a hill or building blocks LOS, in which case the sensor cannot detect the target unit. It can detect a unit through any number of woods/jungle hexes.



C-ANG-0 Archangel, Fortieth Shadow Division (Word of Blake)

INTRODUCTION

ADVANCED  
GROUND MOVEMENT

ADVANCED  
COMBAT

ADVANCED  
BUILDINGS

ADVANCED  
SUPPORT  
VEHICLES

GENERAL  
RULES

ADVANCED  
SUPPORT VEHICLE  
CONSTRUCTION

ADVANCED  
WEAPONS  
AND EQUIPMENT

INDEX

RECORD SHEETS



When using magscan sensors, the larger a unit is, the more easily it can be detected. For any unit from 80 to 100 tons, the range of the sensor is expanded for that unit(s) alone by 1 hex (as described above for infrared sensors). For any unit from 101 to 1,000 tons, the range of the sensor is expanded for that unit(s) alone by 2 hexes. For any Large Craft or Large Naval Vessel, the range of the sensor is expanded for that unit(s) alone by 3 hexes.

Units that weigh less than 20 tons cannot be detected by a magscan sensor, including all infantry.

If using Planetary Conditions, a magscan will not detect a unit that occupies a Heavy Industrial Zone hex.

**Commanders:** If using commanders (see p. 191), a sub-force commander can make two different types of sensor rolls, while a force commander can make three different types of sensor rolls (this includes rolling for his own sensors and/or rolling to monitor remote sensors).

**Communications Equipment:** If a unit on a side mounts 3 to 6 tons of communications equipment (see p. 212, *TM*) or a cockpit command console (see p. 360), once the player has rolled the dice to use a sensor, the player then rolls 1D6. On a result of 1–3, the numerical value below the original dice roll result is added to it; on a result of 4–6, the numerical value above the original dice roll result is added. For example, a player with a Beagle Active Probe rolls 2D6 for sensor detection and gets a result of 6, meaning he detects any enemy units in medium range. Because his side has communications equipment, he immediately rolls 1D6 and gets a result of 3. This means that that a 5 is added to the original 6 (5 is one numerical value less than 6). Such a result doesn't change anything in this example; however, if the player had rolled a 4, then 7 would have been added to the 6, meaning the player would detect any units in the medium and short range brackets.

If a unit on a side mounts 7 or more tons of communications equipment, once the player has rolled the dice to use a sensor, the numerical values above and below the original dice roll result are also added. For example, on a result of 5, the values of 4 and 6 are added.

These benefits apply to all units on a side, but the units mounting the equipment must be on the playing area; if they leave the playing area for any reason (to retreat, due to off-map movement (see p. 192) and so on), these benefits are lost. Additionally, if the communications equipment or cockpit command console loses its Initiative bonuses for any reason (see *Communications Equipment* and *Cockpit Command Console*, p. 212, *TM*, and 300, respectively), the benefits of these items for double-blind play are lost as well (if the Initiative bonuses are recovered, these benefits also resume). Only a single communications equipment or cockpit command console bonus can be applied in this fashion.

Note that the 67-hex range for monitoring a remote sensor is not changed, regardless of the communications equipment available to a side (see below).

**Remote Sensors:** As noted in the *Remote Sensor* rules (see p. 375), if a unit mounts any of the following equipment and is within 67 hexes of a friendly remote sensor, it can monitor that friendly remote sensor: active probe, C<sup>3</sup> master computer, improved C<sup>3</sup> computer, cockpit command console or communications equipment. In place of rolling for its sensors, the controlling player of the unit in question can instead roll for one remote sensor (regardless of how many it can monitor), with all the same results applied as noted above.

**Satellites:** If a unit on a side has established an uplink with any type of Satellite (see *Establishing Uplink*, p. 194), add 1 hex to all range brackets of all sensors on the Sensor Range Table. Only a single Satellite range bonus is applied, regardless of how many different Satellite uplinks exist.

Note that the 67-hex range for monitoring a remote sensor is not changed (see above).

### ECM/Stealth Systems

Just as special sensors can make spotting enemy units easier, special ECM and stealth systems can make units harder to detect.

As a general rule, ECM/stealth systems mask a unit's nature and precise location from enemy sensors, but the systems' powerful jamming devices make it clear to the enemy that something is out there.

In the double-blind game, all ECM and stealth systems modify the die roll results of spotting units attempting to detect an enemy unit equipped with such an ECM system. Because different ECM/stealth systems have different effects against different probes and sensors, the modifiers vary depending on the spotting unit's probe/sensor and the enemy unit's ECM system. These modifiers appear in the ECM/Stealth Modifier Table. Once the sensor detection dice roll has been made (including adding any bonus modifiers from the controlling player's side), the player consults the ECM/Stealth Modifier Table and adds the applicable modifier to the roll result.

To be affected, the spotting unit must be in the normal operating radius of the ECM/stealth system (note that stealth systems only affect the target unit and do not have a radius of effect, and so are only taken into consideration for the unit mounting that equipment). LOS does not affect this radius. If a spotting unit is within the range of multiple ECM systems, combine the effects of all the ECM systems.

Though ECM systems can prevent a sensor probe from identifying a unit, they also produce powerful, distinctive electromagnetic signatures. If a spotting unit is in range of an active ECM device and fails to detect the ECM-equipped unit, inform the player that his unit has been jammed by an ECM suite. Stealth systems do not have such a signature and so the player is not informed if a stealth-equipped unit manages to remain hidden from a probe; if the unit mounts equipment with "ECM" in its title (even if the ECM only affects the target unit's hex), or if the equipment must have an active ECM to operate (such as Stealth Armor or a Void-Signature System), then the player is informed that jamming has occurred.

**ECCM:** If using the ECCM rules (see p. 100), players can use ECCM to cancel out ECM, thus making it harder or easier to detect various units.

*To demonstrate the various interactions of equipment and sensor rolls in a double-blind game, we'll begin with the Line of Sight Diagram on p. 100 of Total Warfare, modifying as described below. In addition, Dusk and Blowing Sand Planetary Conditions are in play; as the Blowing Sand provides the more severe penalty, only that penalty is used.*

*First the gamemaster determines if any visual spotting occurs. Looking on the Visual Range Table for Blowing Sand, the gamemaster notes that the 'Mech in Hex A only has a 10-hex visual range. This will allow it to see the DropShip in Hex B, the WiGE in Hex D and the infantry in Hex C, as they all fall*



in the 'Mech's forward firing arc. The 'Mech in Hex E is also within 10 hexes, but the light woods and heavy woods in between the two units means that LOS does not exist and so the 'Mech in Hex E remains undetected.

Next, the gamemaster verifies the additional bonuses available to the 'Mech in Hex A in preparation for sensor spotting. The 'Mech is piloted by a force commander (see p. 191) and so will be able to make three separate sensor detection rolls. In addition, 'Mech A's side includes a Mobile HQ on the playing area and is in communication with a Satellite.

The player decides to make a Sensor Check with the Beagle Active Probe the Raven mounts, as well as a magscan and a seismic Sensor Check. The player makes three rolls for the respective Sensor Checks, with the following results: 3, 5 and 7.

Now the gamemaster must apply the various benefits.

First, the Satellite provides a 1-hex range increase to all range brackets, so the three sensors used in this example now appear as follows.

Sensor System	Short (2D6 = 7-8)	Medium (2D6 = 5-6)	Long (2D6 = 2-4)
Beagle Active Probe	1-13	14-26	27-39
'Mech Magscan Sensor	1-11	12-22	23-33
'Mech Seismic Sensor	1-3	4-6	7-9

Next, because of the Mobile HQ, the values above and below each dice roll result are also counted, giving the following rolls: 2-3-4, 4-5-6, 6-7-8.

Now it's time to determine how those Sensor Checks stack up against the rest of the units in the Line of Sight Diagram and the equipment they mount. Though it was the last check made, after a quick look at the playing area, the gamemaster knows that even with the Satellite-boosted range on the seismic sensor, only the 'Mech in Hex E falls into that sensor's range bracket. The original die roll result of 7 normally would have meant that only a unit in short range could have been detected: 1-3 hexes. However, the Mobile HQ boosted the roll to a 6-7-8, meaning that both short and medium range brackets are detected: 1-6 hexes. As the 'Mech in Hex E is 5 hexes away, it may be detectable. Even though the 'Mech mounts an Angel ECM, which would normally provide a hefty blocking bonus against sensors, it has no effect against the seismic sensor. However, the 'Mech in Hex E did not expend MP during the Movement Phase of the current turn, and so the 'Mech in Hex E is not revealed.

The next easiest sensor to check is the magscan, as only the units in Hex F and Hex J weigh more than 80 tons. The dice roll result of 4-5-6 means that units in the sensor's long and medium ranges would be detected. The 'Mechs in Hex F and Hex J are in short range, at 11 hexes. However, they both weigh 80 or more tons, which means that if they are within 1 hex of a detection range bracket, they are detected. As both are at 11 hexes, 1 hex away from the medium range detection bracket, both units are detected.

Finally the gamemaster turns to the Beagle Active Probe. The 'Mechs in Hexes E, G and J were not revealed by the previous sensors. However, the 'Mech in Hex J has

a hill hex in the LOS and so the probe is blocked. That leaves the units in Hexes H, I, E and G. The 'Mech in Hex H mounts the Void-Signature System, while the VTOL in Hex I mounts a standard Guardian ECM (the 'Mechs in Hexes E and G do not mount special equipment). Checking the original dice roll result, the gamemaster sees that a result of 2-3-4 occurred (the original result was a 3). For the units with the special equipment, he now applies those modifiers, as they work against a Beagle: a +6 and +4 modifier, respectively. For the 'Mech in Hex H, that changes the roll from 2-3-4 to 9-10-11, which means it cannot be detected (though the gamemaster would tell the player that an ECM system defeated the scan). For the VTOL in Hex I, the dice roll result is changed to 6-7-8, which actually moved the sensor detection into the short-range band (meaning the VTOL did not mask well enough), and so the VTOL in Hex I is revealed. Finally, the 'Mechs in hexes E and G both are in the short-range bracket for the Beagle Active Probe and so remain hidden.

## WEAPON ATTACK PHASE

After both players have moved their units and the gamemaster has conducted all necessary spotting, the Weapon Attack Phase takes place. Only targets that have been spotted by a friendly unit in that turn may be attacked. All standard weapons-fire rules apply.

Resolve each weapon's fire by going first to one player with the unit record sheets and double-blind movement charts of all potential targets. The player then resolves his attacks and the gamemaster records the results on the proper record sheets. Once all weapons fire has been resolved, the gamemaster returns the record sheets to the appropriate players and has them resolve any Piloting Skill Rolls.



DK

A Pleiades Hussars convoy's sensors fail to spot hidden battle armor from Hansen's Roughriders.

INTRODUCTION

ADVANCED  
GROUND MOVEMENT

ADVANCED  
COMBAT

ADVANCED  
BUILDINGS

ADVANCED  
SUPPORT  
VEHICLES

GENERAL  
RULES

ADVANCED  
SUPPORT VEHICLE  
CONSTRUCTION

ADVANCED  
WEAPONS  
AND EQUIPMENT

INDEX

RECORD SHEETS



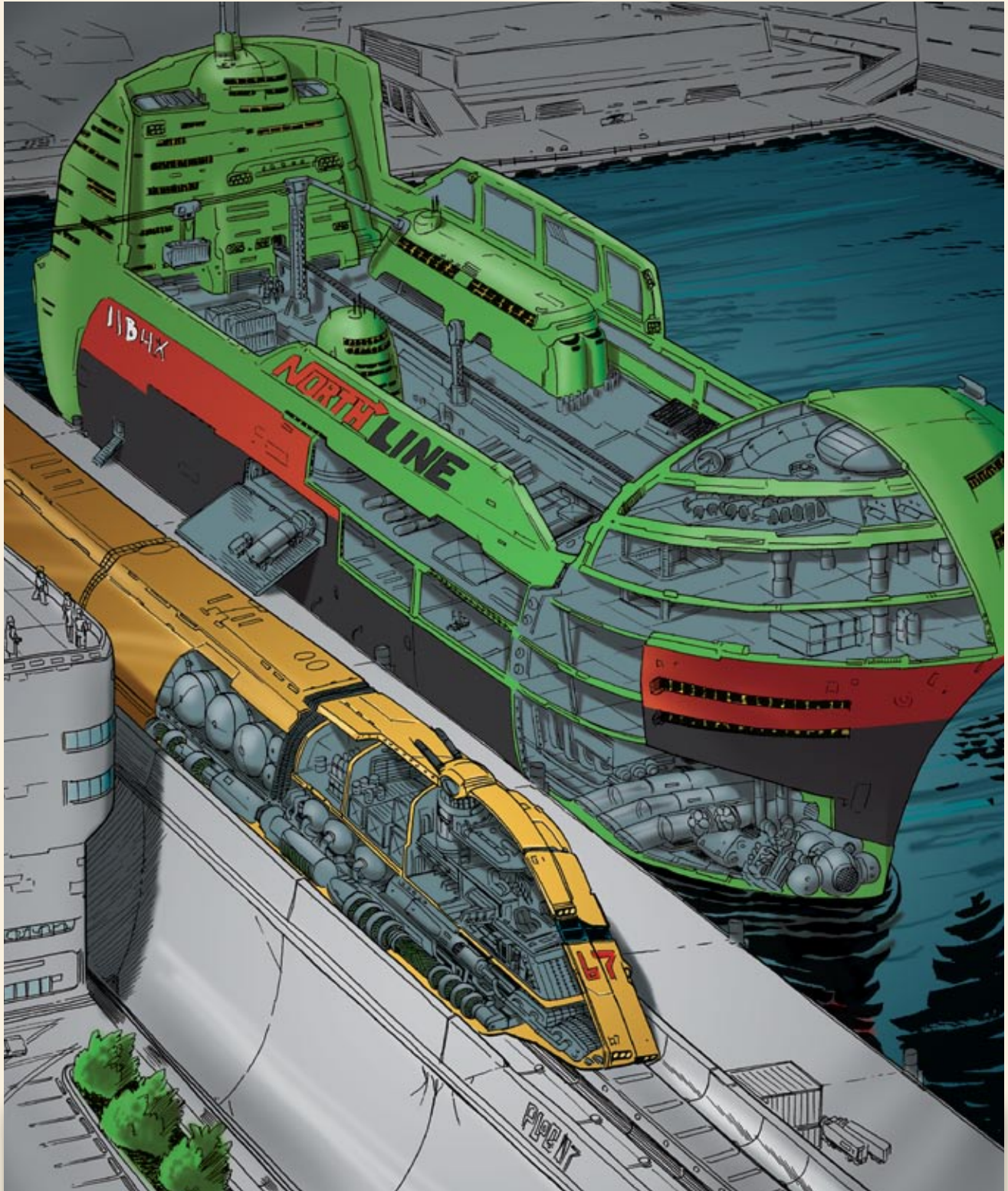

*"Human beings have used powered railways for almost thirteen centuries, a reality that is unlikely to change. Where humankind's waterborne vessels cannot deliver goods, railways are most often assigned that task."*

# UNSUNG TECHNOLOGIES

Hello, I'm Professor...Assistant Professor Dietrich Mathers and I'm here to give you an overview on some of the less common vehicles in humankind's service. You should know most of this, but I'm supposed to give you an overview anyway while Professor Ready is away. Well, maybe the stuff about the ships and trains and airships might be new to you, since they don't get in the news as often as BattleMechs and JumpShips. Let's start with surface vehicles.

## SURFACE VEHICLES

You've probably seen or heard of most of these, but they're in Dr. Ready's syllabus, so...

### RAIL

The earliest native-built ground transportation systems on humanity's far-flung colonies are often railroads. They are less expensive to build than roads for conventional wheeled vehicles, support considerably more cargo, and need less infrastructure to establish. Also, as it is not unusual to find super-continents on the water-poor worlds that humanity often settles, railroads can deliver goods nonstop to most colony sites on a planet.

With little variation, trains are made of chains of dedicated engine cars and cargo cars, called the tractor and trailers, respectively. In large trains, or those that regularly deal with steep slopes, it is not unusual to find extra engine cars. Such trains can be the largest land vehicles in operation: groups of engines and trailers can stretch several kilometers long and haul tens of thousands of tons in cargo. In practice, ten thousand tons is regarded as a practical, manageable maximum.

Trains are a mature technology, to the extent that there exist among them two major variations in propulsion: traditional wheeled railroads and maglev. Maglev offers advantages in speed and maintenance—less rail and train wear—but the expense of maglev lines compared to steel rail often makes the savings difficult to recoup even over years of operation. Wheeled propulsion, on the other hand, is a technology well within the grasp of even the most backward worlds, and advanced worlds find that with centuries of experience and application of advanced technology, wheeled trains remain highly competitive. It is therefore not unusual to see lightning-swift maglev passenger trains paralleling wheeled freight rail lines on advanced worlds like Atreus, Tharkad and New Avalon.

Hidden beneath the shells of the engine cars is another demonstration of the maturity of train technology: the power plant. Though you can find a lot of variation in the fine details and even some very exotic engines in trains across humanity's worlds, trains usually exhibit a lot of similarity in their engines.

Maglev trains, for example, all work in virtually the same way, harnessing magnetic fields to levitate trains by magnetic repulsion (or attraction, when "lift arms" of the train wrap around to the underside of the maglev rails and are drawn upward). Propulsion is also almost universally the same: the train and rails work like two parts of a linear motor, a traditional

circular electric motor unwound and stretched the length of the track. Braking is achieved by applying power in reverse or turning the linear motor system into a generator and dumping the electricity generated through a resistor grid. That's called dynamic braking. Power is typically drawn inductively from the maglev line.

Conventional trains are also fairly standardized. Except for the odd steam train or experiment with hydraulic transmission, most trains use electric motors to drive the wheels of their engine cars. The only big difference is the source of electricity. In the Inner Sphere, the two most popular power plants are fuel cells and combustion engines, typically diesel-cycle piston engines or multi-fuel turbines. Batteries are not unknown for light passenger rail or switchyard engines, but they are generally less popular than externally supplied electricity...that's electrified rail lines, the rails you should never, ever pee on, no matter how drunk you are.

The last major power source for trains is fusion, which is generally restricted to advanced worlds. Most planets that can power trains with fusion engines prefer to build large, stationary power plants and electrify the rail lines. The upfront cost of electrified lines is higher, but fusion engines require specialized technicians and maintenance facilities. Also, a crashed fusion-powered train can scatter radioactive engine shielding. Like maglev trains, the electric motors of wheeled trains usually feature dynamic braking, where the motors reverse their function to become generators. This electrical generation robs the train of momentum, reducing wear on conventional friction brakes.

The area where trains vary the most is their trailers, not the underlying technology, and even then freight containers are largely standardized across the Inner Sphere. Container trailers are typically either flatbeds with room for a single, standard 12m x 2.5m x 2.5m shipping container or two in-line 6m containers, or they are "well cars" that suspend one 12m container just centimeters above the rails between the trailer's wheels (in a "well") so another full-sized container can be stacked atop, thus doubling the container capacity per car. That arrangement cuts costs—fewer cars for the amount of cargo.

After container cars, the two next most common are tank cars—large tanks that carry liquids ranging from milk to molten sulfur—and then gondolas and hopper cars for unpackaged dry cargo like ores, coal and grains. Passenger cars appear in myriad forms depending on the needs of the rail line; for example, urban mass transit "cattle cars" are quit a bit different from cabin-filled long haul "sleeper" cars.

INTRODUCTION

ADVANCED  
GROUND MOVEMENT

ADVANCED  
COMBAT

ADVANCED  
BUILDINGS

ADVANCED  
SUPPORT  
VEHICLES

GENERAL  
RULES

ADVANCED  
SUPPORT VEHICLE  
CONSTRUCTION

ADVANCED  
WEAPONS  
AND EQUIPMENT

INDEX

RECORD SHEETS

Countless specialized cars also exist: stock cars for animals, box-cars for general non-container freight, auto racks for shipping automobiles, refrigerator cars (“reefer cars” to English speakers) for shipping perishable goods (though these are often replaced by refrigerated containers), flat cars and many others.

Human beings have used powered railways for almost thirteen centuries, a reality that is unlikely to change. Where humankind’s waterborne vessels cannot deliver goods, railways are most often assigned that task.

## NAVAL VESSELS

Of course, while the worlds on which humanity settles are often said to be water-poor and therefore encourage land-based transportation, the large majority of settled planets are habitable without substantial terraforming, and such habitability only exists where there is sufficient water. Mother Terra set a high standard for what constitutes large oceans, but even planets with water covering a mere ten percent of their surface may have bodies of water the size of small continents. Navigable rivers are even more useful to young colonies than railroads. And where do you find populations clustering on water-poor worlds? Near the life-giving water, of course.

Though many worlds are termed “water-poor,” it is more correct to call them poor in potable water. Many of the worlds that could only be colonized economically with the advent of the Ryan Cartel ice ships or the technological advances of the Star League are covered in vast, if polluted, oceans. The inhabitants of such worlds might not drink that water, but they certainly do not ignore its potential.

What does all this mean?

It means that naval vessels are a big deal on most worlds even if you don’t see them every day. You would be hard pressed to find a cheaper means of shipping goods to market than by water, and the technological requirements are laudably low. Wooden sailing ships were delivering a kiloton of grain across open seas two thousand years before the steam-powered train was a twinkle in an engineer’s eye, and twenty-five hundred years before DropShips managed to lift the same payload. With basic steelmaking and steam engine

technology—well within the capabilities of almost every planet in the Inner Sphere and hundreds more in the Periphery—it is possible to send a hundred thousand tons (or more!) of freight across an ocean with less infrastructure than a comparable transcontinental rail system, and with far less expense and technology than would be required of a DropShip fleet of the same capacity. Even the most advanced worlds of the Inner Sphere, like New Avalon and Terra, have more freight capacity on their seas than in any other form.

It is difficult to characterize watercraft in one lecture, even when restricted to the class of large naval vessels, which leaves out boats below 300 tons and the workhorse giants above 100,000 tons. But I’ll take a stab at it.

## Military Vessels

The smallest class of large naval vessels is military vessels. Naval military vessels, not to be confused with spacegoing WarShips, are a rare breed in the Inner Sphere due to the repeated lessons of the Age of War, the Amaris Coup and the early Succession Wars. Simply put, naval military vessels make dandy targets during a real war. In addition to fighters, which have been killing military naval vessels for more than eleven hundred years, many modern weapons work exceedingly well against surface military vessels. From the early 23rd century onward, capital weapons on spacecraft rendered surviving surface naval vessels obsolete. Naval warships could not carry weaponry able to respond to the capital weapons of WarShips, and they could not readily run and hide from the much swifter space-based hunters. WarShips are rare in this day and age, but DropShips armed with capital weapons can perform much the same tasks.

With big budgets and bureaucratic inertia, Terran Alliance and Hegemony wet naval forces managed to build fleets of submersible vessels that could elude most capital weapons. Not only are hundreds of cubic meters of water great for stealth, but that much water also makes effective armor. Of course, the Terran Hegemony found imitators, and the Age of War offered the chance to test the value of such submersible military vessels. The result? The modern multi-environment sensor suites that made underwater combat so effortless for BattleMechs also rendered the stealth of submersibles an illusion. A combination of sensor buoys and capital missiles with

## WHAT ARE THEY GOOD FOR?

There are a handful of useful niches for military wet-navy vessels. Open ocean patrols for domestic issues, like search and rescue and piracy suppression, are well-served by small surface ships (500 to maybe 5,000 tons) that should never see combat against front-line military threats. The Davions’ *Rapier*-class patrol destroyer is actually a fine vessel for such duties thanks to its speed, endurance, medical facilities, marine complement and VTOL capacity.

Another role for military vessels, preferably submersibles, is the mobile military base, a ship that acts like a military base for other units. This sort of ship frees land, air or sea units aboard it from the vulnerability of a fixed land base. Not only are such vessels useful in defense during raids and invasions, they are also an excellent means of making a planetary occupation difficult or untenable. The classic example is the submersible aircraft carrier, but as the fate of the Regular *Argos* demonstrates, it may be difficult to properly employ such carriers. In addition to aircraft carriers, land troops and special forces can benefit from mobile basing on large military vessels.

A problem that has stymied carriers’ proliferation is shortages of supporting units. Everyone would love their homeworld to have a dozen submersible carriers each with a regiment of aerospace fighters or BattleMechs or both, but in practice it’s an uncommon world that can muster a regiment of even conventional fighters for anything, let alone carriers.

Even gunboats have their place on the seas of the Inner Sphere. Military vessels meant for direct combat, from missile submarines to blue-water cruisers, are limited to fighting asymmetric opponents, the (usually) backward foes who lack the fighters or WarShips to deal with such aquatic giants. For example, a handful of *Jormungands* would do a fine job defending the islands and coastal cities of a world raided by pirates—the interstellar kind, I mean. In general, though, direct-combat vessels are not the sort of ship you want trading shells with a major military; the advantage of surprise offered by such ships rarely works more than once against such foes.

anti-submarine warheads, often with nuclear and/or torpedo submunitions, or aerospace fighters armed with torpedoes, made short work of submarines. New generations of admirals had these lessons beaten into them again during the Amaris Coup and early Succession Wars.

Today, naval military vessels are undergoing a small resurgence due to the depletion of specialized anti-naval weaponry from military inventories. The early Succession Wars killed the large naval vessel, so Houses stopped stocking anti-shipping weapons, and so now many militaries are building them again because most opponents are ill-equipped to fight them. This foolish cycle of thinking is already costing lives, however, as anti-shipping weapons return to service. Tharkad's three Jormungand-class cruisers were all sunk within a week of the start of the Word of Blake blockade, at the hands of our own *Invincible*, no less. And at least a dozen Rapier-class destroyers throughout the Federated Suns have been casually sunk since 3068 during raids, primarily by DropShips armed with capital missiles. We know a couple of Regular Argo submersible carriers were lost to fighter strikes; they were unable to launch their conventional fighters in self-defense because the looming threat of Word of Blake orbital bombardment kept them submerged. I've heard we've kept a Luftenburg surface carrier functional on Tharkad, which has got to be quite a trick.

Large military vessels may capture the limelight on occasion, but they're a tiny fraction of large naval vessels in service, found on only a few worlds. The dull commercial vessels make up the vast majority of this ship population.

### Freighters

The majority of ships on the Inner Sphere's seas are freighters: bulk carriers, liquid carriers or general freighters.

Bulk carriers typically represent around a third to two-fifths of large naval vessels in operation. They haul unpackaged cargo, such as ore, coal, wood chips, cement powder and other materials readily handled by conveyor belts, scoop cranes or pumps.

Liquid carriers represent another sizable portion of shipping. Fuel tankers are perhaps the most famous for their concentrated wealth and importance to modern society. The bulging lines of liquid hydrogen tankers and the blocky shapes of petrochemical and freshwater tankers are well known to most people. Small ships, those under 50,000 tons, find use in making deliveries to small customers shipping less common liquids, like acid, wine, ammonia and so on.

The last major category of freighter is the general freighter, though in most cases this could be called the "container ship" category. Only a few worlds use a much less efficient system of loose cargo on pallets in their freighters, the "break bulk" system. The blocky container ships are filled with stacks and blocks of standard shipping containers that can usually transfer easily to other forms of transport, like trains and trucks. Containers standardized since the Terran Alliance era are 12m long, 2.5m high and 2.5m wide, with variations being fractions of those dimensions. Containers come in an endless variety—some are refrigerated, some hold liquid tanks, some are collapsible, and there is always the eponymous dry goods shipping container. Container ships have remained a dominant force in shipping for more than a millennium because of their efficiency: even

without automated systems, the manpower requirement for loading, shipping and unloading tens of kilotons of freight in a few days is barely three score workers.

Freighters in any form offer incredibly efficient transportation, particularly the multi-hundred kiloton behemoths beyond the scope of this lecture, to the extent that mills can find cheaper grains or foundries cheaper ores an ocean away rather than from sources just 50 kilometers distant overland.

### Specialist Vessels

Beyond these three broad freighter categories are the specialists: automobile carriers, passenger liners, cable layers, ice-breakers, ferries, heavy lift ships, drillships, dredgers and many others. The fine details of those also are beyond the scope of this lecture and, in comparison to freighters, are almost secondary anyway

### Common Features of Ships

Most ships, particularly the various freighters and tankers, have many basic similarities in design. These ships are large, rectangular displacement hulls that concentrate their engines, controls and crew in one section, typically the stern or the center. They dedicate the remainder of the hull to cargo space, and pay lip service toward reducing hydrodynamic drag with some hull shaping that does not affect the shape of the cargo bays. Monolithic cargo holds or tanks are rare to minimize flooding dangers. Instead, most ships subdivide their interiors; for example, a typical bulk freighter of 100,000 tons will have five to ten cargo bays. Most specialist ships share these features.

Only in the more unique specialists ships do variations appear. Passenger liners, for example, often stretch a large superstructure across the top to provide as many balcony cabins as possible. Automobile carriers are similar to passenger liners in concept though not appearance, using very large superstructures to hold as many vehicles as possible and arranging their interiors for "roll on, roll off" cargo operations. Some engineering craft such as ocean dredgers vary almost from owner to owner.

The common displacement hull is not alone on the seas. Modern hydrodynamics combined with modern power plants offer ships far higher speeds than can be obtained from simple displacement hulls. Semi-planing hulls, planing hulls, hydrofoils, sidewall surface effect hulls, catamarans, trimarans and more exotic styling allow ships on advanced worlds to push beyond 100kph. The Lyran *Jormungand* cruiser is one such swift vessel, and its fusion power plant allows it to sustain its sprint speed for months on end. Unlike smaller watercraft, where features like hydrofoils are noteworthy, hulls sculpted for speed in large naval vessels are simply a matter of course and subsumed in the weight of the propulsion system.

## AIRSHIPS

Airships, whether called by that name, blimps or zeppelins, cover a range of flying machines that use lighter-than-air gases for lift. These useful vehicles required several centuries to enter widespread service. The first airships, developed on

INTRODUCTION

ADVANCED  
GROUND MOVEMENT

ADVANCED  
COMBAT

ADVANCED  
BUILDINGS

ADVANCED  
SUPPORT  
VEHICLES

GENERAL  
RULES

ADVANCED  
SUPPORT VEHICLE  
CONSTRUCTION

ADVANCED  
WEAPONS  
AND EQUIPMENT

INDEX

RECORD SHEETS

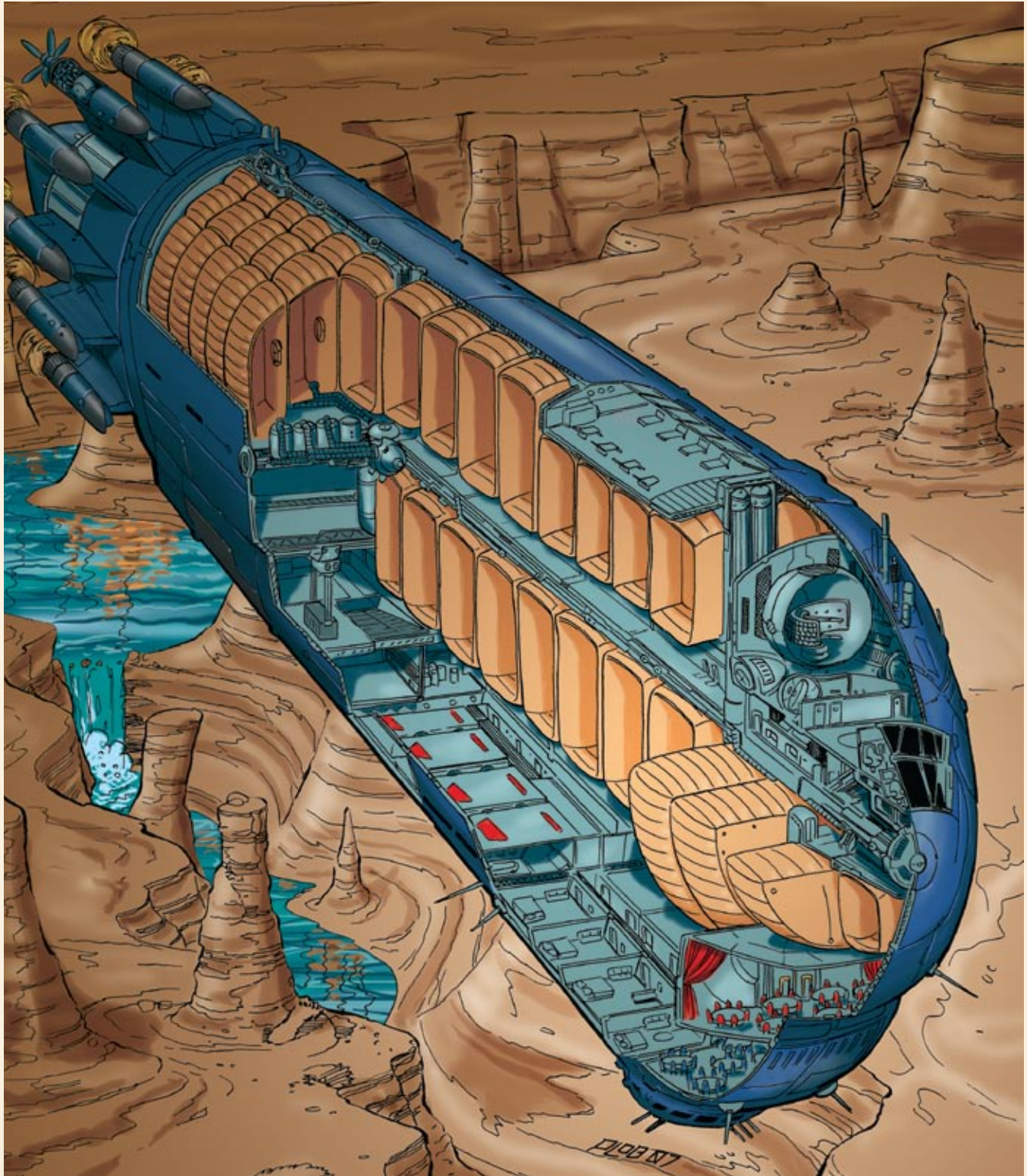

*"Over the decades and centuries, those colonies established with airships found new uses for the vehicles that Terra overlooked. Not only did smaller airships come to compete with other types of aircraft for existing roles (police airships and scout zeppelins), they opened entirely new industries."*

Terra, had a habit of crashing and/or bursting into flames, plus they had competition from fixed wing aircraft and market inertia to contend with. However, the popularization of cruise airships in the Terran Alliance led to a proliferation of airships and creation of new roles for these flying vehicles.

Airships initially made little headway on Terra even during the "aerial cruise" craze, but Terra's offspring had no such compunctions and eagerly took advantage of the growing know-how in these unique vehicles. Colonists needed vehicles that could operate without roads, without large landing strips, and without much fuel. Airships met all those criteria and more. Airships were capable of feats not readily duplicated by any other flying vehicle. For example, their capabilities as sky cranes surpassed even fusion-powered VTOLs. Not only could airships of common sizes lift hundreds more tons than the largest VTOL, they required much less effort and maintenance to remain on station for hours or days at a time. Airships could also operate in trackless wilderness, establishing bases, ferrying supplies and removing valuable products (diamonds, gold, timber and so on) that not even VTOLs could match. Many frontier towns and outback farms on new colonies depended on airships to deliver hundreds of tons of fuel, fresh water, animal feed, fertilizer and countless other supplies.

Over the decades and centuries, those colonies established with airships found new uses for the vehicles that Terra overlooked. Not only did smaller airships come to compete with other types of aircraft for existing roles (police airships and scout zeppelins), they opened entirely new industries. On Skye, for example, builders took centralized factory construction beyond small, trailer-based homes to skyscrapers. Factories would assemble most of a new building in modules, except the foundation, and airships would deliver the module to the distant city and settle the module in position, serving both as ferry and sky crane. The idea was not entirely new, but it was far easier for airships to hoist building components massing several hundred tons into position than for ground-based cranes to do it. The ability to move hundreds of tons of cargo at a time over any terrain has also found airships work in earthmoving and civil engineering projects.

The largest airships, beyond the scope of this discussion, are capable of even greater feats. Kilometer-long airships are not unknown on some worlds and can lift over ten thousand tons of cargo. They are not strictly cost-competitive with trains or naval vessels, but do present some unique abilities, like permanently airborne "aerial cruiseliners."

Airships generally fall into three structural classes: non-rigid airships (blimps), semi-rigid airships and rigid airships (zeppelins). Rigid airships build an enclosing cage and separate skin called collectively, "the envelope," surrounding a multitude of separate gas bags, the balloons that hold the lifting gas. A dozen or more gas bags are common in rigid airships. The envelope may also enclose most of the crew, cargo and engine sections rather than placing them in an exterior gondola. The many separately inflatable gas bags and rigid hull make this style of construction the most popular among freighter aircraft, which deal with shifting loads and therefore need good positional control.

Non-rigid and semi-rigid airships make the envelope and the gas bag one and the same, and obtain most of their shape from internal gas pressure rather than a rigid frame. Because

the interior of the envelope is filled with lifting gas, most equipment and cargo volume are located in an external gondola. Semi-rigid airships add a stiff keel or partial internal frame, typically a large triangular truss running through the envelope, to help maintain its shape and distribute point loads, like engines or dense payloads, across the entire envelope.

## SATELLITES

Satellites are an overlooked workhorse of modern civilization. From communication relays to weather monitors to navigation—I can't read my own handwriting...ah, beacons!—to navigation beacons, satellites directly touch almost every human being alive today in some way.

The flexibility of modern technology means that a simple summary of a satellite's statistics can make two models of satellites with very different roles look very much alike. IrTech's recent "Vehicle Annex" was a case point; that compilation made it look like a planet-monitoring science satellite and a reconnaissance satellite had very similar equipment aboard. That's almost true. Despite such similarities, however, satellite users tend to request satellites for specific missions, which break down (roughly) into the following common classes of satellites: communications, recon, weather and navigation.

### SATELLITE TYPES

Modern communications satellites often handle multiple roles, from relaying media broadcasts, to handling two-way conversations, to monitoring distress beacons, to serving as navigation beacons. Of course, some satellites may be more specialized, but the mass-produced comsats of the Inner Sphere tend to pack software reconfigurable to suit the needs of the owners.

Reconnaissance satellites typically carry a mix of powerful optical, infrared and radar sensors to monitor a planet. Weather satellites monitor a planet's weather with sensors often superficially very like those of reconnaissance satellites, though the large lookdown radar on a weather satellite should not be mistaken for having the same 'Mech-tracking abilities as a spysat's lookdown radar. Despite this, I'm told the "it's a weather satellite" excuse has been used to disguise all sorts of naughty satellites since the dawn of space travel.

Navigation satellites can be considered a specialized communications satellite (those where navigation isn't already a function of a communications satellite). These orbital radio beacons help travelers on a world's surface determine their location.

And then there are the specialists: the unusual (but trendy) orbital cache satellites, solar power satellites, astronomical satellites, private habitats and small science labs, and many others.

### ORBITS

Satellites end up in many of the same locations as space stations, as well as several others. However, their distri-

INTRODUCTION

ADVANCED  
GROUND MOVEMENT

ADVANCED  
COMBAT

ADVANCED  
BUILDINGS

ADVANCED  
SUPPORT  
VEHICLES

GENERAL  
RULES

ADVANCED  
SUPPORT VEHICLE  
CONSTRUCTION

ADVANCED  
WEAPONS  
AND EQUIPMENT

INDEX

RECORD SHEETS

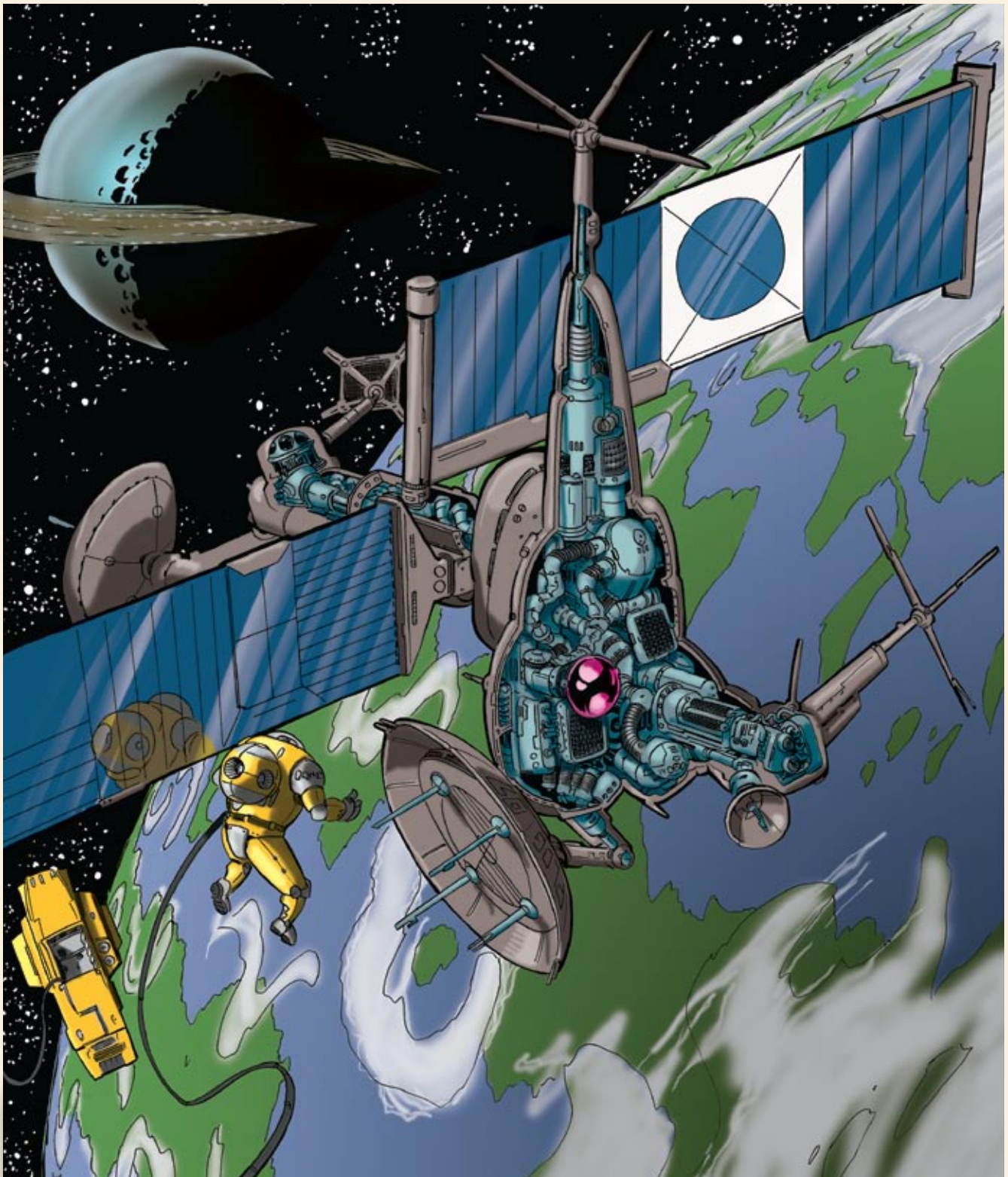

*"...And then there are the specialists: the unusual (but trendy) orbital cache satellites, solar power satellites, astronomical satellites, private habitats and small science labs, and many others." .....*

butions are different. Satellites tend to cluster in low orbits (mostly equatorial, some polar) and geosynchronous orbits, with few satellites elsewhere.

Geosynchronous orbit tends to be dominated by communications satellites, which benefit the most from a stable position with respect to planetary customers. You'll find a few other satellites in that band, like weather satellite "floaters" meant to keep the widest possible, continuous view on a hemisphere, but ask politely before putting a satellite here. Communications companies tend to be rabid about protecting their profitable orbital slots, and at least two such companies have WarShips and BattleMechs. The almost unique and anachronistic Taurian solar power satellites also work well in geosynchronous orbits. (You wouldn't want your power plant wandering away from the hamlet it powered, would you?)

Geosynchronous orbits are not perfect for all communications, especially closer to planetary poles where the satellites would appear low to the horizon and thus need to transmit through considerable thickness of atmosphere. For such high-latitude communications, comsats usually end up in "Molniya" orbits. My notes say that's Old Russian for "lightning," because Molniya orbits dip very close, very fast past a planet for part of their path. These orbits are sharply inclined—tilted—compared to the equator of the planet. They're also very eccentric, stretched into comet-like orbital shapes. These orbits are usually selected to be either half of a local day or a full local day in length. (Technically, full-day Molniya orbits are called "Tundra" orbits.) These comet-like orbits put the satellite over the target region of the planet for most of the orbital period, with brief close passes to the planet. The result is that the satellite seems to almost hover over the targeted extreme northern or southern region.

Navigation satellites tend to be in medium and high orbits, but not (by preference) geosynchronous orbits. Navigation satellites providing a global positioning system will not give global coverage from a geosynchronous orbit for the same reason geosynchronous comsats have trouble covering polar regions.

Polar orbits tend to be the domain of planetary science satellites, some weather satellites, and reconnaissance satellites. Polar orbits are generally at low altitudes, too.

Except for L-1 points (which are often close to viable pirate jump points), LaGrange points rarely receive satellites unless there are a lot of space stations present. Generally, you might find a few astronomical satellites parked at L-4 and L-5 points. L-1 points, though, may receive system defense early warning satellites, which are reconnaissance satellites with a fancier name.

Satellites are also distributed into solar orbits—around a system's star, but not around any planet. These satellites are typically part of a system's early warning network, looking to spot any unusual jump signatures in non-standard locations around the system. The short range of typical radar and optical sensors means these satellites have little chance of spotting passing DropShips or WarShips unless the satellites are deployed by the millions, but the signature of an arriving JumpShip can be spotted for many astronomical units (AU). It's therefore feasible to guard the fringes of a star system with just a few satellites.

Locations where it's rare to find satellites are zenith and nadir jump points. I'll talk about this further when I address space stations and JumpShips. While fusion-powered satellites can hold station for a decade on the average fuel load, the station-keeping ion thrusters of fission- and solar-powered satellites are only good for a year before depleting their reaction mass. And their chemical motors can be exhausted much faster. To get around this, some satellites use true light sails large enough to overcome their weight at the jump point, keeping station indefinitely. This usually requires a sail area as large as a JumpShip's solar sail. Despite similarity in size and sometimes shape, a "light sail" is easily distinguished from a JumpShip's solar sail by color. A light sail is silvery because it tries to reflect as much light as possible, while a solar sail is black because it tries to absorb as much light as possible.

## MOBILE STRUCTURES

I disagreed with Dr. Ready about this section, as I think it represents an arbitrary class of vehicles that doesn't really exist. But, as he so cleverly reminded me, I'm the one who mouthed off on a live, publicly broadcast lecture about both our esteemed nobles and honorable democratic agitators, and so I'm the assistant professor while he's the full professor. So here we are, talking about mobile structures at the end of the lecture instead of discussing these vehicles as part of the topics I went over earlier.

According to Dr. Ready, the definition of a mobile structure is "a vehicle so large as to hardly be a vehicle in the traditional sense." Dr. Ready's classification of these vehicles is so large that it encompasses everything from submersible, semi-mobile oil rigs to the giant "sky cities" of the Star League.

### MOBILE GROUND STRUCTURES

Okay, honestly, the example I have of a mobile ground structure probably typifies a "mobile structure," since I can't think of anything else to call it.

Anyway, a good example of "a large structure that has limited mobility" would be the DropShip transporter. These "crawlers," nicknamed after behemoths that date to the dawn of spaceflight, are tracked vehicles that putter around spaceports at one or two kilometers per hour with spheroid DropShips on their backs. Aerodynes can move themselves around on their wheeled landing gear, but spheroids are stuck where they land unless something carries—Yes? Please speak up.

Okay, yes, spheroid DropShips can take off, hover and scoot over a spaceport to a new location. However, spheroid drive exhaust is extremely hazardous to anyone underneath it. Having a DropShip launch to a safe altitude, like fifty kilometers, and then move sideways in the middle of a busy spaceport's skies, before landing about a kilometer from where it started, is overkill. Hence, the crawlers.

Crawlers are typically shaped like squat, massive squares of metal and ablative armor, sometimes up to two hundred and fifty meters on a side to hold even a *Mammoth*

INTRODUCTION

ADVANCED  
GROUND MOVEMENT

ADVANCED  
COMBAT

ADVANCED  
BUILDINGS

ADVANCED  
SUPPORT  
VEHICLES

GENERAL  
RULES

ADVANCED  
SUPPORT VEHICLE  
CONSTRUCTION

ADVANCED  
WEAPONS  
AND EQUIPMENT

INDEX

RECORD SHEETS



*"Don't fall prey to Succession War-era nostalgia. The Star League did not have anti-gravity. The Skycity-3000s were big balloons and enclosed nineteen separate helium gas bags in a single, rounded hexagonal envelope of a rigid composite, like an oddly shaped zeppelin." .....*

on their back. They have multiple tracks, often on individually steerable legs, which distribute their own massive loads and that of their cargoes across the ground. Despite their scale, they are rarely operated by more than a handful of crew. Of course, dozens of ground crew may be assigned to support the crawler's "DropShip wrangling," but the actual act of driving a crawler only takes a few people.

Picking up a DropShip is an interesting exercise. The usual requirement is for a DropShip to settle on an existing landing pad that is actually propped some distance above the ground. The crawler slides under the pad and picks up both pad and DropShip before trundling them to the hangars. In other cases, the crawler *is* the landing pad. One interesting variation uses a system of floodable landing pads that float a DropShip to a lock that is drained, leaving the DropShip on a mobile landing pad that a crawler can drive under once the water's mostly gone. There are a few side-loading crawlers, though it's pretty difficult to pull a DropShip sideways onto the top of one.

As crawlers are rarely in a great hurry and don't like to have an 11,200-ton *Mule* start wobbling on their backs, they typically trundle along at a kilometer or two per hour. Crawlers may be surprisingly underpowered, with just a few hundred or thousand kilowatts. Because they don't move quickly, they can use relatively small power plants geared down through electric drive systems to produce mammoth amounts of torque. It is also not unusual to see crawlers with load-leveling systems that keep their cargo platforms flat while they climb shallow grades.

### MOBILE AERIAL STRUCTURES

Not to be confused with the largest airships, mobile aerial structures are less-streamlined giants exemplified by the General Motors Aerospace Skycity-3000, of which a couple dozen were manufactured in the late 27th and early 28th centuries. These were meant as exotic resorts and high-priced real estate for the ultra-wealthy of the Star League. Today, I think there's one left on Mizar and one on Luthien, though the Lyran "skycity" isn't a GM model. I'll stick to the Skycity-3000 because it was the most common and best known. Can anyone paint a picture of a Star League city without putting a Skycity-3000 overhead?

Don't fall prey to Succession War-era nostalgia. The Star League did not have anti-gravity. The Skycity-3000s were big balloons and enclosed nineteen separate helium gas bags in a single, rounded hexagonal envelope of a rigid composite, like an oddly shaped zeppelin. Underneath this giant balloon was the actual Skycity platform, which was about one hundred meters in diameter.

A hundred meters in diameter is a lot smaller than those sprawling aerial estates look in "Wonders of the Star League," don't they? That's because the Skycity-3000s were modular, mostly as a practical design issue, and designed to dock together to form much larger aerial wonderlands. The Luthien platform has twenty modules about four hundred meters in diameter.

The multi-tiered platforms were where the fun was. Even a single Skycity-3000 module was the size of a large resort hotel. In addition to its basic arresting hoists and aircraft hangars for passengers and crew, the Skycity-3000 had roomy dining and entertaining areas, plenty of balcony rooms with outstanding views, and open sun decks or sports areas on their topsides. Except for large sports areas, like a football field, there was never a shortage of volume for the ultra-wealthy who visited or lived in these aerial cities. The limitation was one of weight. Several thousand tons of capacity might sound like a lot, but it runs out real fast when you're trying to install hundreds of luxury rooms into an aerial hotel. One of the biggest disappointments to the ultra-rich was the lack of open water on the Skycity-3000s—a small backyard pool might contain fifty tons of water, and a decent resort-sized pool could be thousands of tons. Of course, GM was happy to customize the basic frames of its Skycity-3000s to meet the needs of its customers.

The Skycity-3000s were not entirely passive blimps. Their fusion hearts powered some massive, carefully muffled fans that could move them at up to thirty kilometers an hour, give or take. That usually kept them out of the harshest weather. If not, their very low centers of gravity kept them enormously stable in bumpy weather. You didn't shake fifteen thousand tons of airship with a little turbulence.

### MOBILE NAVAL STRUCTURES

I hinted about these earlier while discussing naval vessels. Most of what I said there applies to these giants. Sure, mobile naval structures sometimes include the unusual mobile oil rigs or vast vessels designed to look like islands, and I've got some pretty pictures here of the Atlantis Arcology on Atreus, which putters around Atreus' seas at about 10kph.

But, really, most of what Professor Ready wants to call "mobile naval structures" are just big ships. When a planet has waters and ports deep enough to support them, ships over one hundred kilotons are where the money is made. They are hardly more expensive to build than their smaller brethren, operating costs per ton drop, and they deliver more in the same time. If it wasn't for the limits of ports, straits, and artificial canals to handle these giants, most planets would be happy to be populated with megaton container ships that ply some routes on New Avalon and Luthien.

## INTERMISSION

Alright, let's break here for five minutes to stretch our legs. This was an introduction to some of the unsung workhorses of the modern universe, the ones that hide on or near planets. Maybe this will give you enough material to look in the right places to get a passing mark when Dr. Ready throws a research paper at you about some obscure light sail zenith point early warning satellite or an Avalonmax containership. After the break, we will address the much flashier vessels that fill our newscreens: spacecraft.

INTRODUCTION

ADVANCED  
GROUND MOVEMENT

ADVANCED  
COMBAT

ADVANCED  
BUILDINGS

ADVANCED  
SUPPORT  
VEHICLES

GENERAL  
RULES

ADVANCED  
SUPPORT VEHICLE  
CONSTRUCTION

ADVANCED  
WEAPONS  
AND EQUIPMENT

INDEX

RECORD SHEETS



PE

*IndustrialMechs perform routine maintenance at a rail yard.*

The unit construction rules described in *TechManual* covered the range of *Classic BattleTech's* most common battlefield and support units, but the list was far from exhaustive. Left out—because they feature more advanced or involved rules and capabilities in game play—were an assortment of other Support Vehicles. Satellites, Rail units, Large-sized Airship and Naval Support Vehicles; these exist in significant numbers in the *Classic BattleTech* universe as well. Far less common are the so-called Mobile Structures: super-massive units that can serve as mobile command centers and industrial support facilities and can even dwarf a DropShip in sheer size.

The following system enables players to construct these so-called “advanced units” for *Classic BattleTech* games that conform to the *Total Warfare* rules (as modified by use of this book). As these rules can be fairly math-intensive, designers are encouraged to do all work on scratch paper before committing the resulting unit’s specifications to the appropriate blank Record Sheets.

These rules should be considered the standard rule set for advanced unit design in the same fashion as the *TechManual* rules covered the basic rules for constructing tournament-legal units. These rules do not delve into any experimental options that may be available in the equipment section of this book (see p. 274).

## THE BASICS OF ADVANCED UNIT DESIGN

Advanced unit construction relies on three primary factors: unit type, technology base and weight. The notes below explain and expand on these factors.

Throughout these construction rules, the term “unit” refers to a single advanced unit for *Tactical Operations* game play. A unit may be a single Satellite, Rail unit (tractor [engine] or railcar), a single Large-sized Support Vehicle, or a single Mobile Structure.

### UNIT TYPE

The advanced units presented here come in a range of unit types that largely determine their core construction rules, maximum weight allowances, structural designs and what equipment they may mount. These features are broadly outlined below. Because so much is influenced by the unit’s type—including its core construction rules and Record Sheet—this factor must be decided upon first in the design process.

### Advanced Support Vehicles

Advanced Support Vehicles include Satellites, Rail Vehicles and Large-sized Airships and Naval Vessels. Because their construction rules derive from those of Support Vehicles (see pp. 116-139, *TM*), the construction rules for these units are grouped together in their own section.

**Satellites:** Satellites can weigh up to 200 tons and may only operate in space. These units use the Support Vehicle construc-



tion rules, even though they use the same game play rules as Space Stations and are commonly unmanned.

**Rail Vehicles:** Rail Vehicles can weigh up to 600 tons each, and come in two broad classes: conventional rail and magnetic levitation (MagLev). These units use the Support Vehicle construction rules.

**Large-Sized Airships:** Large-sized Airship Support Vehicles range from 300.5 to 1,000 tons in weight. They use the Support Vehicle construction rules and function like their smaller kin in game play, with few exceptions.

**Large-Sized Naval Vessels:** Large-sized Naval Support Vehicles range from 300.5 tons to 100,000 tons in weight, and may operate only on water of sufficient depths. They use the Support Vehicle construction rules and function similarly to their smaller brethren, but with significant differences due to their greater size.

### Mobile Structures

Mobile Structures are more akin to buildings than they are to any other kind of battlefield unit, but unlike buildings, Mobile Structures can move about, either by land, sea or air. These multi-hex units use a unique construction system that relies more on size, shape and mobility type rather than a raw tonnage value.

### TECHNOLOGY BASE

In *Classic BattleTech*, all units broadly fall into one of two available technology bases: Inner Sphere or Clan. (Mixed technology bases are possible, per the *Advanced Construction Options* starting on p. 376, but will not be covered here.) Purely Inner Sphere advanced units may only use Inner Sphere equipment, while purely Clan advanced units may only use Clan equipment. Many standard components, however, such as armor, control systems, engines and heat sinks, are considered universal and so may be available to both technology bases.

### Technology Rating

In the Weapons and Equipment Tables used for creating units in this book and in *TechManual*, all items receive a Technology Rating in addition to a technology base. This rating (expressed as a series of letter grades that define the level of technology and its availability through the major eras of *Classic BattleTech* history) helps to define the item's level of sophistication and may be used to help standardize the level of advancement the unit demonstrates for purposes of era-based campaigning. An item's Technology Rating typically has no direct bearing on advanced unit design, though units built using the Support Vehicle construction rules (Rail Vehicles, Satellites, Large Airships and large Naval units) must determine the Technology Ratings of their core structural components before proceeding.

### Omni Units

Some—but not all—of the advanced units presented in these rules may be constructed as modular (Omni) units. Omni units are advanced units designed for rapid reconfigurations between missions, and are available to Clan and Inner Sphere technology bases. Unless otherwise noted, Omni units use the same construction rules as standard advanced units, but

when an Omni is made, the designer must first establish its base configuration, which includes its chassis, engine, control systems, armor and—if desired—any additional weapons and heat sinks “hardwired” to the design.

The weight, weapon slots and arrangement for all this equipment is considered “fixed” on all configurations of the Omni unit, leaving any leftover weight and internal space open to pods that can mix and match additional heat sinks, weapons and equipment based on mission needs. A base Omni-unit configuration is never considered a finished unit and is generally not legal for game play (as such units are essentially open frames of empty pods). Only the completed Primary and Alternate configurations (which must always comply with the rules for constructing standard advanced units) are considered game play-ready.

Mobile Structures use a different type of modular design, where structure segments are chained together in a semi-permanent arrangement, and so these units also may not be built as Omni units.

### WEIGHT

Most of the advanced units described in these rules use the tonnage standard, with the weight ranges legal for game play described above under *Unit Type*. Small-sized Satellite and Rail Support Vehicles, however, use the kilogram standard instead.

For purposes of construction, though the term “weight” is typically used, it reflects the mass of items and components rather than a weight based on gravity.

### Weight and Unit Classes

The varied nature of these advanced units creates a different range of weight and unit classes than most other unit types covered in *TechManual*. Still, depending on the unit's weight and type, many advanced designs can be classified along similar lines, though unusual specializations and such remain possible within the weight limits of any given design.

**Satellite Support Vehicles:** Satellite Support Vehicles fall into the Small, Medium and Large size classes common to Support Vehicle units. As the only Support Vehicle type that is routinely fielded unmanned, Small-sized Satellites tend to be civilian models, used for automated communications and weather monitoring. Medium-sized Satellites are usually more militarized or industrial models, some of which may even be crewed, based on their functions—which can range from observational roles to combat defense and even limited production. Large-sized Satellites are uncommon, but are usually manned and can serve as miniature orbiting habitats and production facilities or even spaceports for lighter craft (like fighters).

**Rail Support Vehicles:** Rail Support Vehicle units run along pre-laid tracks that can be underwater, in vacuum or over land. Small-sized Rail units are typical of commuter trains or mass transit for small-scale bases, while Medium-sized Rail Vehicles may see use as cargo trains, heavy commuter traffic or even military supply units. Large-sized Rail Vehicles are occasionally armed or armored and may be used as part of a local defensive network (though this is fairly uncommon). In addition to classifying a role and size, Rail Vehicles also distinguish between tractors (Rail units that pull or push other Rail units)

INTRODUCTION

ADVANCED  
GROUND MOVEMENT

ADVANCED  
COMBAT

ADVANCED  
BUILDINGS

ADVANCED  
SUPPORT  
VEHICLES

GENERAL  
RULES

ADVANCED  
SUPPORT VEHICLE  
CONSTRUCTION

ADVANCED  
WEAPONS  
AND EQUIPMENT

INDEX

RECORD SHEETS



and trailers (or cars, which lack engines and must be drawn by tractor units).

**Large-sized Airship and Naval Support Vehicles:** Truly massive (compared to the Small- and Medium-sized versions shown in *TechManual*), Large-sized Airships and Naval Vessels are Support Vehicles most commonly used as super-heavy transports for long-distance duties—often transoceanic or cross-continental work. Large-size Naval Vessels are also favored for military work, though they have long since been sidelined by the much more adaptable DropShips and aerospace forces of the modern age. Armed and armored ships often patrol water-rich worlds to deter local pirates or act as a kind of shore defense/artillery unit, though carriers are equally common and present a unique strategic puzzle for invading forces.

**Mobile Structures:** Mobile Structures defy classification by weight, but can have a broad range of functions. Some of the more common might include DropShip haulers, used to carry massive DropShips from one landing pad to another, or mobile oil rigs that meander along coastlines for accessible reserves. Land-based Mobile Structures can be moving military bases, mining rigs and factories, while airborne ones may serve as aerial observation platforms, research centers, military headquarters or mobile “cloud cities” (an extravagance of the forgotten Star League era).

## SPACE

Under these rules, an advanced unit’s size and type determine its equipment capacity and weapon limits. These limits are largely based on the construction rules the unit uses.

---

# DESIGNING ADVANCED SUPPORT VEHICLE UNITS

---

The following basic rules cover the construction of all advanced Support Vehicle unit types featured here. (Advanced aerospace units and Mobile Structures will follow in their own sub-sections). Despite their broad range of types, all of these advanced units follow six simple design steps, each of which is described in detail later. In brief, these steps are as follows:

**Step 1:** Design the Chassis—Determine the advanced Support Vehicle’s type, its tech base (including Structural Tech Rating), its weight and (for select units) any internal structure and chassis modifications.

**Step 2:** Install Engine and Control Systems—Determine the advanced Support Vehicle’s motive and engine type, speed (or acceleration), engine weight, control components, fuel (if applicable) and (for some units) its Structural Integrity.

**Step 3:** Add Armor—Determine type, amount and weight of armor (if any) and allocate armor points.

**Step 4:** Add Heat Sinks—Determine number and weight of the advanced Support Vehicle’s heat sinks.

**Step 5:** Install Weapons and Equipment—Add weapons and other equipment to the advanced Support Vehicle.

**Step 6:** Complete the Record Sheet.

These steps are a framework for designing an advanced Support Vehicle. The actual process—particularly after the chassis, engine and control systems are determined—can involve a bit more flexibility as weapons, armor and heat sinks are balanced for their best fit in terms of tonnage and weapon slots. For example, some designers might wish to assign armor after the weapons and heat sinks are established, to maximize firepower over protection. Others may want to add weapons before adding more heat sinks, to see if those that come free with the engine are sufficient for the unit’s needs.

To assist in this effort, the designer may find it useful to make copies of an appropriate Blank Record Sheet (in the back of this book), to visually arrange the placement of weapons and equipment while tracking the use of weight on a piece of scratch paper.

**Terminology:** For the sake of simplicity, any reference under these rules to advanced Support Vehicles refers to all Satellite, Rail, Large Airship and Large Naval Vessel Support Vehicle units. Where a rule applies only to select Support Vehicle types, the specific units are noted.

---

## STEP 1: DESIGN THE CHASSIS

---

The first step in creating an advanced Support Vehicle is choosing the unit’s chassis. This step establishes some of the most basic aspects of its design, determining what type of Support Vehicle it is, its technology base and its weight. These choices will restrict the designer’s access to certain equipment and can also influence the weight of the unit’s internal structure or structural integrity.

### CHOOSE ADVANCED SUPPORT VEHICLE TYPE

Advanced Support Vehicles come in a variety of types that can affect their motive systems, maximum weight, terrain restrictions and engine efficiencies. Because of this, choosing an advanced unit’s type is the first key part of the chassis design process. Even the selection of a proper Blank Record Sheet for use in unit design hinges on the choice of unit type before any other component.

The Advanced Support Vehicle Types Table below provides key data that applies to advanced unit design and game play. Each of the unit types covered by these rules is listed in the Unit Type column, along with its upper Size-Class Limit, its Weight Range in tons (beyond which advanced units of that type may not be constructed), Weight Incremental (the increments of tons that the unit may vary in weight within its range), and Restricted Terrain (areas impassable to units of that type in *Total Warfare* game play). The Advanced Support Vehicle Record Sheet Table (see p. 239), meanwhile, determines which Blank Record Sheet must be used to record the construction of a new advanced unit of a given unit type.

**Rail Units:** While not required for construction purposes, when designing a Rail Support Vehicle, it is advisable to build both an engine or tractor unit (the primary mover for the train) and at least one railcar (of equal or lesser size) at the same time. This way, the completed design can take full advantage of the capabilities of a complete Rail unit.



## ADVANCED SUPPORT VEHICLE TYPES TABLE

Unit Type	Size-Class Limit*	Weight Range (Tons)	Weight Incremental (Tons)	Restricted Terrain
Satellite	Large	0.100 to 200	0.001 (Small); 0.5 (Medium/Large)	Any Non-Space
Rail	Large	0.100 to 600	0.001 (Small); 0.5 (Medium/Large)	All Non-Rail terrain**
Large Airship†	Large	300.5 to 1,000	0.5	Any Woods, Hills, or Structures at same altitude†
Large Naval	Large	300.5 to 100,000	0.5	All except Water (Depth 1+)‡

\*The Airships and Naval Support Vehicles covered under these rules are only those of the Large size class.

\*\*Rail units must use the appropriate rail type (MagLev rails for MagLev Rail units, Standard Rails for non-MagLevs).

†Airship Support Vehicle types use Aerospace Fighter movement and combat rules, but may not operate on the High-Altitude Map.

‡Higher minimum depth requirements imposed for heavier Naval Support Vehicles

## ADVANCED SUPPORT VEHICLE RECORD SHEET TABLE

Unit Type	Record Sheet	Weapon Arcs
Satellite (All sizes)	Satellite	Nose, Left, Right, Aft
Rail (Small/Medium)	Ground	Front, Left/Right, Rear*
Rail (Large)	Large Ground	Front, Front-Left/Right, Rear-Left/Right, Rear*
Large Airship	Airship	Front, Front-Left/Right, Rear-Left/Right, Rear
Large Naval	Large Naval	Front, Front-Left/Right, Rear-Left/Right, Rear*

\*Plus any Turret(s) installed

Eric wants to design an unmanned unit to aid in planetary communications. He decides on a Satellite Support Vehicle, which he names the SEU-193D Starcomm. In preparation for the design process, he reads a copy of the Satellite Record Sheet.

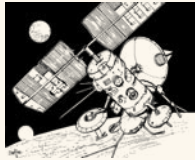

Frank is designing a new train system for passenger and cargo transport, and has thus chosen a Rail Support Vehicle type for his design. He names his unit the Adelante, and prepares a Rail Record Sheet to aid in his design.

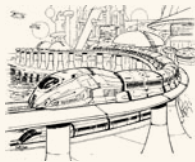

George is building a Large Airship that will serve as an airborne command center and aircraft carrier. Choosing to name it the Cloud Nine Carrier, he reads an Airship Record Sheet to record his work.



Henry wants to create a seagoing cruiser to protect the Tharkan shorelines—not to mention its small carrier fleet—against bandits and invaders (however unlikely they may be). Naming his vessel the Jormungand, he gets a Large Naval Record Sheet prepared.



### CHOOSE TECHNOLOGY BASE

Advanced Support Vehicles may be constructed using Clan or Inner Sphere technology bases. Units created using either tech base may be built as Advanced Support OmniVehicles, but must incorporate the Omni chassis modification to do so (see *Allocate Weight for Internal Structure*, p. 242).

Eric is building his SEU-193D Starcomm for House Davion's use, and so picks an Inner Sphere technology base.

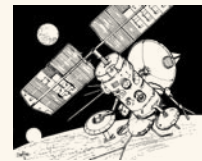

Frank's passenger train system is meant for commercial use in the Inner Sphere, so he also picks an Inner Sphere tech base for both the engine unit (the primary tractor) and the railcars. To take advantage of modern modular construction, he decides that the Adelante's railcars will be built as Support OmniVehicles, though the primary tractor itself will not be.

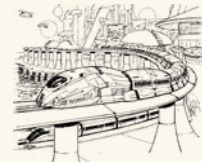

George chooses an Inner Sphere tech base for his Cloud Nine Carrier.



Henry decided already that his Jormungand is a Lyran-made design, so it gets an Inner Sphere tech base.



INTRODUCTION

ADVANCED GROUND MOVEMENT

ADVANCED COMBAT

ADVANCED BUILDINGS

ADVANCED SUPPORT VEHICLES

GENERAL RULES

ADVANCED SUPPORT VEHICLE CONSTRUCTION

ADVANCED WEAPONS AND EQUIPMENT

INDEX

RECORD SHEETS



## CHOOSE WEIGHT

Depending on the Advanced Support Vehicle's type (see p. 239) and its size class (Small, Medium or Large), its maximum (and minimum) weight varies greatly (as shown on the Advanced Support Vehicle Types Table).

For Small-sized Advanced Support Vehicles, designers may choose any weight under 5 tons, up to a maximum of 4,999 kilograms (in 1-kilogram increments). Construction of such units is handled using a kilogram standard, so when installing any items with weight listings in tonnage, the designer must first convert the weight of such items to kilograms. To do this, multiply the item's tonnage by 1,000.

All other Advanced Support Vehicles described in these rules track their weight using the tonnage standard, and may be constructed as light as their lowest listed weight from the Advanced Support Vehicle Types Table, to their maximum listed weight, increasing from the minimum in multiples of the unit's listed Weight Incremental. Because of the tonnage standard, the designer must first convert to tons any desired items with a weight listing in kilograms. To do this, divide the item's kilogram weight by 1,000.

The Advanced Support Vehicle Weight Table below defines the weight ranges of each advanced unit that may be designed under these rules, by unit type and size class. Regardless of the advanced unit's size and type, the total weight for its engine, equipment, armor and other components must not exceed the weight chosen. Any unspent weight left after the creation process is considered cargo space, if the vehicle still has equipment slots to spare, or wasted weight if it does not.

## Space

In addition to determining the maximum total weight of all equipment and components that comprise an advanced unit, its weight can also determine the maximum amount of items that may be mounted.

For all advanced Support Vehicles weighing 300 tons or less, the equipment space limit is 5 base item slots, plus 1 additional slot for every 10 tons (10,000 kilograms) of advanced Support Vehicle weight (rounded down). Advanced Support Vehicles weighing over 300 tons receive 35 base item slots, plus 1 additional slot for every 100 tons of unit weight (rounded down). For example, a 48-ton Support Satellite may carry up to 9 slots for items (5 base +  $[48 \text{ tons} \div 10] = 9.8$ , round down to 9 item slots), while a 65,000-ton Large Naval Vessel may carry up to 685 slots' worth of items (35 base +  $[65,000 \text{ tons} \div 100] = 685$ ).

Like other Support Vehicles, advanced Support Vehicles mount equipment less efficiently than their battlefield kin. Rather than occupying one slot per item, equipment mounted in a Support Vehicle may occupy a variable amount of equipment slots, as indicated by the Support Vehicle Slots column on the Weapons and Equipment Tables.

## Advanced Support Vehicle Base Chassis/Engine Values

In addition to the weight ranges and Minimum Technology Ratings (see *Choose Technology Rating*, below), each type and size class of advanced Support Vehicle also has a corresponding Base Chassis Value and Base Engine Value. These values—shown in the Advanced Support Vehicle Weight Table below—are required to compute the final chassis and engine weights for these units, and are included here to avoid undue repetition. When choosing a weight for an advanced Support Vehicle, the designer should note these values as well.

## Multi-Hex Units

Large Airships, Large Naval Vessels and continuous Rail Support Vehicles (those consisting of an engine (Tractor) unit and more than one railcar (Trailer)) can occupy more than one hex in *CBT* game play for purposes of stacking rules and considering weapon mounts. For Large Airships and Naval Vessels, the total weight of such units defines the hexes that they occupy and their levels (expressed as above and below the waterline, for the sake of surfaced Naval Vessels; landed Airships and submerged Naval Vessels use the total of both figures to define their height from the unit's "bottom"). These values are defined in the Airship and Large Vessel Size Template Table (which also includes the number of hexes of length—and therefore the number of CASE units required—for such units). Rail units occupy 1 hex for every 2 Small- or Medium-sized units in the train, or 1 hex for every Large-sized unit in the train. Trains need not be linear, but must follow the contours of the tracks (see *Rail*, p. 149).

Based on the applicable template, a to-hit modifier applies to attacks made against Large Airships and Naval Vessels, reflecting the greater ease with which others units can hit such large targets, even when they are in motion. These modifiers apply in all aspects of game play, including weapon and physical attacks, and attacks against Airships in the air and on the ground. Large Airships in flight are considered to occupy 1 hex, however, for purposes of maneuvering.

Additional movement rules apply to multi-hex units as well. These are discussed under *Advanced Support Vehicles* (see pp. 148).



Artillery units are off-loaded from a military train.



## ADVANCED SUPPORT VEHICLE WEIGHT TABLE

Vehicle Type (Size)	Weight Range (Tons)	Minimum Tech Rating	Base Chassis Value	Base Engine Value
Satellite (Small)	0.100 – 4.999	C	0.08	0.10*
Satellite (Medium)	5 – 100	C	0.12	0.10*
Satellite (Large)	100.5 – 200	C	0.16	0.10*
Rail (Small)	0.100 – 4.999	A	0.15	0.003
Rail (Medium)	5 – 300	A	0.20	0.004
Rail (Large)	300.5 – 600	A	0.30	0.005
Airship (Large)	300.5 – 1,000	C	0.30	0.012
Naval (Large)	300.5 – 100,000	B	0.17	0.009

\*Fixed Engine Weight; Satellite Support Vehicles have an effective Thrust Point value of 0 in game play.

### Advanced Support Vehicle Item Slots\*

(Small/Medium): 5 + (Support Vehicle Tons ÷ 10)

(Large): 35 + (Support Vehicle Tons ÷ 100)

\*Round down to the nearest whole number

INTRODUCTION

ADVANCED  
GROUND MOVEMENT

ADVANCED  
COMBAT

ADVANCED  
BUILDINGS

ADVANCED  
SUPPORT  
VEHICLES

GENERAL  
RULES

ADVANCED  
SUPPORT VEHICLE  
CONSTRUCTION

ADVANCED  
WEAPONS  
AND EQUIPMENT

INDEX

RECORD SHEETS

## AIRSHIP AND LARGE VESSEL TEMPLATE TABLE

Support Unit Template (hexes)	Airship Weight(in Tons)*	Naval Weight(in Tons)	Height (Levels) Above / Below Surface	Attacker To-Hit Modifier
A (1)	0.1 – 500	0.1 – 500	0 / 1**	0
B (2)	500.5 – 600	500.5 – 6,000	1 / 1**	-1
C (5)	600.5 – 750	6,000.5 – 12,000	1 / 2**	-2
D (7)	750.5 – 900	12,000.5 – 30,000	2 / 2**	-3
E (9)	900.5 – 1,000	30,000.5 – 100,000	3 / 3**	-4

\*Airships use templates only when landed; Airship height when landed is computed as the sum of both the above and below levels.

\*\*Submersible Large Naval Vessels may not dive in water that exceeds the total sum of both the above- and below-surface Level values. If they attempt to do so, the vessel will run aground (see p. 154).

Eric wants to build his Starcomm as a Medium-sized satellite. He decides on a weight of 20 tons. At this weight, he calculates that his Support Vehicle will have 7 slots of equipment space (5 base slots + [20 tons ÷ 10] = 7 slots).

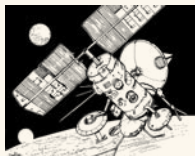

Eric also notes from the Advanced Support Vehicle Weights Table that the Starcomm will have a Base Chassis Value of 0.12 and a Base Engine Value of 0.10.

Frank goes for the biggest train he can with his Adelante Rail Vehicle—at least for the train engine unit itself. He decides on a weight of 600 tons for the primary mover (the top of the Large size class), and 120 tons (Medium size) for the Omni railcars that will go with

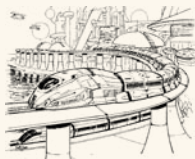

it. At these weights, he calculates that the Adelante's main engine unit will receive 41 slots of equipment space (35 base slots + [600 tons ÷ 100] = 41 slots), while its smaller railcars will receive 17 equipment slots (5 base slots + [120 tons ÷ 10] = 17 slots).

Frank also notes from the Advanced Support Vehicle Weights Table that the Adelante's primary tractor will have a Base Chassis Value of 0.30 and a Base Engine Value of 0.005, while its railcars have a Base Chassis Value of 0.20 and a Base Engine Value of 0.004.

George's Cloud Nine, he decides, will be a Large-sized Airship—the biggest possible, in fact, at 1,000 tons. At this weight, he computes that the unit will have 45 equipment slots (35 base slots + [1,000 tons ÷ 100] = 45 slots).



George also finds that the Large-



sized Airship will have a Base Chassis Value of 0.30 and a Base Engine Value of 0.012. Furthermore, as a 1,000-ton Airship, his unit falls into a Template E size, with a length of 9 hexes, and a total height of 6 levels—but only when landed. At this size, the Airship will also be rather easy to hit, with a -4 Attacker To-Hit Modifier applied against it in the air and on the ground.

Henry decides to give his Jormungand battlecruiser a total weight of 60,000 tons, well in the middle of the Large Naval Support Vehicle weight range. At that weight, he finds that the vessel will have an impressive 635 item slots available ( $35 \text{ base slots} + [60,000 \text{ tons} \div 100] = 635$ ).

Henry also notes the Jormungand's Base Chassis Value is 0.17 and its Base Engine Value is 0.009, as well as the fact that, as a 60,000-ton vessel, his ship falls into a Template E size, with a length of 9 hexes, and a height of 3 levels above and below the waterline. At this size, the vessel will also be rather easy to hit, with a -3 Attacker To-Hit Modifier applied against it.



## ALLOCATE WEIGHT FOR INTERNAL STRUCTURE/STRUCTURAL INTEGRITY

Like standard Support Vehicles, advanced Support Vehicles have internal structures that represent their framework, and may be determined at the same time as their weight is chosen. The weight of this structure depends on the advanced Support Vehicle's weight, as well as its Structural Tech Rating and any special chassis modifications applied. The formula for computing an advanced Support Vehicle's chassis is identical to that of other Support Vehicles.

### Choose Structural Tech Rating

The first step in computing an advanced Support Vehicle's structural weight is the determination of its Structural Technology Rating. This is the rating (expressed as a letter grade A through F) used to define the sophistication of the design's core structure. The Technology Rating Table below helps to define these terms more clearly, and may be used to associate a given advanced Support Vehicle design with a particular era of creation, but should also be seen as a general guide. For example, the Clans can and do make use of technologies rated E or lower, and certain Inner Sphere agencies have access to the occasional homegrown item that merits a Tech Rating of F.

While choosing an advanced Support Vehicle's Structural Tech Rating will help anchor its core design in the universe and establish a standard by which any other components installed may be measured, it merely applies to the internal structure of the vehicle; engines, armor and other equipment installed later may hail from more or less sophisticated technology levels.

For all advanced Support Vehicle types and size classes covered by these rules, the Minimum Support Vehicle Structural Tech Rating may be found on the Advanced Support Vehicle Weights Table. Designers may choose a higher rating in order to save weight, but they may not choose a structural design less sophisticated than indicated by this minimum listed Tech Rating.

### Choose Chassis Modifications

For many Advanced Support Vehicles, special modifications may be applied to the chassis at this time that provide added features

## TECHNOLOGY RATING TABLE

Tech Rating	Technology Level	Sample Advanced Unit Types
A	Primitive (19th to early 20th centuries)	Rail Support Vehicles
B	Low-Tech (late 20th century)	Large Naval Support Vehicles
C	Common Tech (21st to 22nd centuries)	Large Airship and Satellite Support Vehicles
D	High-Tech (Age of War and Succession Wars)	—
E	Advanced (Star League/ Post-3050 Inner Sphere)	—
F	Hyper-Advanced (Clan/ Post-3065 Inner Sphere)	—

not built into the unit's basic design. These chassis modifications not only provide a multiplier for chassis weight computations, but also may modify the unit's Structural Tech Rating, and may be restricted to certain motive types or even incompatible with other chassis modifications.

The Advanced Support Vehicle Structure and Modifications Table below shows all of the chassis modifications applicable to the units covered by these rules, including their Chassis Value Multipliers, Minimum Tech Ratings, restrictions and basic descriptions. If a desired chassis modification has a Minimum Tech Rating higher than that of the Structural Tech Rating chosen, the designer must either forego the modification or raise the unit's Structural Tech Rating to match.

### Calculate Chassis Weight

The basic formula for finding the weight of an advanced Support Vehicle's internal structure is to multiply its Base Chassis Value (as found on the Advanced Support Vehicle Weights Table) by its Tech Rating multiplier, and then multiply that result by each chassis modification multiplier that the designer wishes to apply. The result of all these factors is then multiplied by the unit's total mass (using whichever weight standard applies—tonnage or kilograms) to find how much of the unit's total weight is devoted to its internal structure (or structural integrity, where applicable).

All modification multipliers apply in sequence; designers should not add them up if multiple modifications are employed. Remember that the final value of all computations must be rounded up to the nearest kilogram for Small Support Vehicles, or to the nearest half-ton for Support Vehicles weighing 5 tons and up. For example, a 50-ton (Medium size) Rail unit with Tech Rating B that sports both the External Power Pickup and the Tractor chassis modifications would compute its chassis weight as follows:  $0.20 \text{ (Medium, Rail)} \times 1.3 \text{ (Tech Rating B)} \times 1.1 \text{ (External Power)} \times 1.2 \text{ (Tractor)} \times 50 \text{ tons}$ , for a final chassis weight of 17.16 tons (rounded to 17.5 tons).

### Internal Structure/Structural Integrity Values

An advanced Support Vehicle's type and total weight also determine the number of internal structure points the unit receives per location. The Advanced Unit Structure Values Table shows what



## ADVANCED SUPPORT VEHICLE STRUCTURE TABLES

### ADVANCED SUPPORT VEHICLE STRUCTURE WEIGHT FORMULA

Structure Weight = Base Chassis Value x Tech Rating Multiplier x Chassis Modification Multiplier(s) x Total Support Vehicle Weight

### TECH RATING MULTIPLIERS

Support Vehicle Technology Rating						
	A	B	C	D	E	F
<b>Tech Rating Multiplier</b>	1.60	1.30	1.15	1.00	0.85	0.66

### ADVANCED SUPPORT VEHICLE CHASSIS MODIFICATIONS TABLE

Chassis Modification	Min. Tech Rating	Multiplier	Modification Restrictions
Amphibious	C	1.75	Not available to Hover or Naval Support Vehicles
Armored*	A	1.5	Not available to Airship Support Vehicles
Environmental Sealing	C	2	No Restrictions
External Power Pickup	B	1.1	Rail Support Vehicles Only (may not be used with MagLev Engines)
Omni	E	1	No Restrictions
Submersible	B	1.8	Naval Support Vehicles Only
Tractor (Ground)	A	1.2	Wheeled, Tracked and Rail Support Vehicles Only
Tractor (Naval)	A	1.2	Naval Support Vehicles Only
Trailer	A	0.8	Wheeled, Tracked and Rail Support Vehicles Only
Ultra-Light*	D	0.5	Small Support Vehicles Only

\*Armored and Ultra-Light modifications may not be combined.

### CHASSIS MODIFICATION DESCRIPTIONS

Modification	Description/Features
Amphibious	May traverse or land on water of any depth (unit is considered to be afloat on the water's surface)
Armored	May mount heavier armor types (marked with an asterisk on the Support Vehicle Armor Table)
Environmental Sealing	Fission-, Fusion- and Electric-engine units may operate normally in vacuum or underwater unless breached
External Power Pickup	Allows non-MagLev Rail vehicles to draw electricity through rails, rather than on-board engines
Omni	May be constructed as an OmniVehicle (but may not use Mechanized Infantry rules)
Submersible	May operate as a submarine (may not use hydrofoil mod, if equipped, when submerged).
Tractor (Ground)	May tow other ground units over non-water terrain (up to towing unit's mass)
Tractor (Naval)	May tow other naval units over water (up to 5x the towing unit's mass)
Trailer	No engine required (unit may be towed by a suitable tractor); Not required for naval units
Ultra-Light	May not mount armor better than a BAR of 5 due to lighter structure design

formulas apply to which unit type and size class. Remember that Airships and Satellites receive their internal structure values as a single "location" called Structural Integrity, while all other noted unit types receive internal structure values to each hit location, plus any turrets. When using the appropriate Blank Record Sheet, the designer must mark out any excess internal structure or Structural Integrity circles on the unit's Armor Diagram for all applicable locations to indicate

the number of structure points in those areas. If no turret is assigned to the vehicle (see *Turrets*, below), then all internal structure *and* armor circles for the turret locations must be blacked out.

Like Internal Structure points on BattleMechs, WorkMechs, ProtoMechs and Combat Vehicles, the structure points used by advanced units may not be redistributed to other body locations.

INTRODUCTION

ADVANCED  
GROUND MOVEMENT

ADVANCED  
COMBAT

ADVANCED  
BUILDINGS

ADVANCED  
SUPPORT  
VEHICLES

GENERAL  
RULES

ADVANCED  
SUPPORT VEHICLE  
CONSTRUCTION

ADVANCED  
WEAPONS  
AND EQUIPMENT

INDEX

RECORD SHEETS



The Advanced Support Vehicle Structure Values Table below lists the locations that apply to the various types and size classes of advanced units constructed using these rules.

**Turrets:** Like those on Combat Vehicles, turrets on advanced Support Vehicles are optional components. Of the units covered by these rules, they are available to Rail Support Vehicles and Large Naval Vessels only; Airships and Satellites may not mount turrets as such. Large Naval Vessels may mount multiple turrets, if desired, with a maximum limit of 1 turret per hex of vessel length. See *Large Naval Vessels*, below, for further information.

Any turrets installed automatically receive the same number of internal structure points as the unit's other locations, but these extra points do not directly affect the structure weight. Turrets instead add weight in an independent "turret tonnage" equal to 10 percent of the total mass of all weapons and equipment mounted in them (rounded up to the nearest kilogram for Small-sized Support Vehicles, or to the nearest half-ton for Support Vehicles weighing 5 tons and up). As this decision may not be made until the designer is ready to add weapons and other equipment to the Support Vehicle, the turret weight need not be established at this point. The designer should decide, however, whether or not the vehicle is to have turrets. (See the rules regarding OmniVehicles below for an exception.)

**Large Naval Vessels:** Large-size Naval Support Vessels may install one turret per hex of vessel length (to a maximum of 8 turrets per vessel). A Large Naval Vessel's hex length is defined by its template size as found in the Airship and Large Vessel Template Table (see p. 241).

Some items mounted on a Large Naval Vessel—such as a Helipad or a Flight Deck—may occupy "turret space" as well as internal equipment space. In such cases, the vessel must reduce the number of actual turrets it can mount accordingly.

**Tech Base/Rating:** The internal structure and structural integrity types for advanced Support Vehicles in this section are equally available to vehicles of Clan or Inner Sphere tech bases. However, internal structure or Structural Integrity components featured by these advanced units are incompatible with those of any different unit type.

**Space:** For all of the advanced Support Vehicles discussed here, the various types of structure and chassis modifications have no impact on the unit's equipment slot spaces.

**Advanced Support OmniVehicles:** As the arrangement of internal structure circles is fixed across all advanced Support

Vehicle types and no equipment slots are occupied by structure, advanced OmniVehicle designers need only note whether or not the unit's base configuration is to mount a turret at this time. If so, the turret weight must be pre-determined at this stage as well, based on the maximum weight of weapons the designer wishes to have installed in the Turret location.

As he noted earlier, Eric's Starcomm has a Base Chassis Value of 0.12, and he has given it a total weight of 20 tons. He assigns it a Structural Tech Rating of E (multiplier 0.85) and sees no need for any of the various chassis modifications. He computes the Starcomm's chassis weight to be 2.5 tons ( $0.12 \times 0.85$  [Tech Rating E]  $\times 20$  tons = 2.04, rounded up to 2.5 tons).

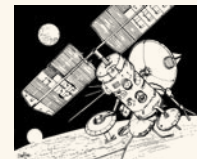

As the Starcomm is a Satellite Support Vehicle, he also finds that it has a Structural Integrity Value of 1.

Frank has assigned a weight of 600 tons for the Adelante's primary tractor unit and 120 tons for its railcar. His tractor unit has a Base Chassis Value of 0.30, while the railcar has a Base Chassis Value of 0.20. For the primary tractor, he selects a Structural Tech Rating of D (1.0 multiplier), and a Rating of F for the Omni-railcars (0.66 multiplier).



Because the primary tractor needs to tow other railcars, Frank naturally assigns it the Tractor Chassis Modification, but sees no need for other chassis modifications. He thus computes a chassis weight of 216 tons for the primary tractor unit ( $0.30 \times 1$  [Tech D]  $\times 1.2$  [Tractor]  $\times 600$  tons = 216 tons). According to the Advanced Unit Structure Values Table, he finds that the 600-ton unit will receive 60 internal structure points to each of its 6 locations (Front, Front-Left, Front-Right, Rear-Left, Rear-Right and Rear—Frank has decided not to install a turret;  $600$  tons  $\div 10$  = 60 points per location).

For the more advanced OmniVehicle railcars, Frank assigns the Tractor and Trailer Chassis Modifications (so they can both be pulled and pull additional cars), as well as the Omni chassis modifications. He thus computes a chassis weight of 15.5 tons for the railcars ( $0.20 \times 0.66$  [Tech F]  $\times 1.2$  [Tractor]  $\times 0.8$  [Trailer]  $\times 1.0$  [Omni]  $\times 120$  tons = 15.206 tons, rounded up to 15.5). According to the Advanced Unit Structure Values Table, he then

## ADVANCED SUPPORT VEHICLE STRUCTURE VALUES TABLE

Advanced Support Vehicle Type (Size)	Structure Values	Internal Structure Locations*
Satellite (All sizes)	1 (SI)	Structural Integrity
Rail (Small/Medium)	Tonnage $\div$ 10*	Front, Left/Right, Rear**
Rail (Large)	Tonnage $\div$ 10*	Front, Front-Left/Right, Rear-Left/Right, Rear**
Large Airship	†	Structural Integrity
Large Naval	30 + (Tonnage $\div$ 2,000)*	Front, Front-Left/Right, Rear-Left/Right, Rear**

\*Round up to the nearest whole

\*\*Plus any Turret(s) installed

†Structural Integrity (SI) for these unit types is determined upon installing the unit's engine (See *Install Engine*, p. 245).



finds that the *Adelante's* 120-ton railcars will receive 12 internal structure points to each of their 4 locations (Front, Left, Right and Rear—no turrets installed;  $120 \text{ tons} \div 10 = 12 \text{ points per location}$ ).

George's 1,000-ton *Cloud Nine* is a Large Airship with a Base Chassis Value of 0.30 and he decides to assign it a Structural Tech Rating of E (multiplier 0.85). With no other chassis modifiers, he computes that its structure will weigh 255 tons ( $0.30 \times 0.85 [\text{Tech E}] \times 1,000 \text{ tons} = 255 \text{ tons}$ ). Because it is a Large Airship, however, George may not yet determine the Structural Integrity value provided for his unit.



Henry's 60,000-ton *Jormungand* battle cruiser has a Base Chassis Value of 0.17. As it is intended to be an older-style vessel, he selects a Chassis Tech Rating of C (1.15 multiplier), as well as an Armored Chassis modification (1.5 multiplier) because he intends this vessel for combat. This gives the vessel a final chassis weight of 17,595 tons ( $0.17 \times 1.15 [\text{Tech C}] \times 1.5 [\text{Armored}] \times 60,000 \text{ tons} = 17,595 \text{ tons}$ ).



Henry also notes the *Jormungand's* weight makes it a Template E vessel, with a 9-hex length, and a height of 3 levels above (and below) the waterline. Though he can mount up to 8 turrets at that size (the maximum allowed for a Large-sized Naval Vessel), Henry opts for a total of 5 turrets instead, and finds that the vessel will receive 60 internal structure points to each of its 11 locations (Front, Fore-Left, Fore-Right, Rear-Left, Rear-Right, Rear and all 5 Turrets;  $30 + [60,000 \div 2,000] = 60$ ).



Sovereign class cruiser, *New Avalon Crucis March Militia* (House Davion).

## STEP 2: INSTALL ENGINES AND CONTROL SYSTEMS

The second step in Advanced Support Vehicle design is the installation of the unit's engines and control systems. This step establishes the key factors in the advanced unit's mobility, including the size and performance of its engine and the weight of the control systems the crew uses during operations.

### INSTALL ENGINE

An advanced Support Vehicle carries one engine to power its movement, equipment and other components. As Advanced Support Vehicles use a wider set of standards than Combat Vehicles, the formula for determining these units' engine weight is slightly more complex than that for a Combat Vehicle, and factors in the advanced Support Vehicle's engine type, Technology Rating and desired speed as well as the unit's overall weight.

The Advanced Support Vehicle Engine Table below provides the formulas and compatibilities of the various engine types available to advanced Support Vehicles (by Tech Rating and type). Determining the weight of an advanced Support Vehicle's engine is simply a matter of multiplying the unit's total weight by its relevant factors. These factors are the unit's Base Engine Weight (a base multiplier of the vehicle's total weight based on its size and motive type), Movement Factor (a value derived from the unit's desired Cruise/Safe Thrust) and Engine Weight Multiplier (a value based on the type and Tech Rating of the engine chosen).

This final engine weight (rounded up to the nearest kilogram for Small-sized advanced Support Vehicles, and up to the nearest half-ton for those weighing 5 tons and up) includes the engine, transmission and any integral cooling systems and shielding necessary to operate the engine.

If the compatibility of an engine type is noted as "N" (in the Compatibility column on the table) for a given advanced Support Vehicle type, that engine type may not be installed on that advanced Support Vehicle. If a given Engine Weight Multiplier for a Tech Rating is listed as "NA" (in the Multiplier column on the table), that engine type is unavailable at that Tech Rating.

At the designer's option, an advanced Support Vehicle may mount an engine at a different Tech Rating than its chassis (either higher or lower). If a higher-rated engine is used, however, it will drive up the unit's overall Tech Rating accordingly.

**Minimum Engine Weights:** In advanced Support Vehicle design, Fusion engines of Tech Rating C and Fission engines of all Tech Ratings have minimum engine weights that must be satisfied during construction. This minimum engine weight is 5 tons (5,000 kilograms), regardless of the Support Vehicle's size, weight, speed or motive type.

If the computed weight of the vehicle's engine is less than this minimum, the designer must either increase the vehicle's speed until an engine weight that meets the above criteria is found, or inflate the engine's weight to meet these minimums without increasing performance. For example, a 4,500-kilogram satellite may not install a Fusion engine with a Tech Rating of C or any kind of Fission engine, because the satellite itself is smaller than minimum engine size requirement. However, a

INTRODUCTION

ADVANCED  
GROUND MOVEMENT

ADVANCED  
COMBAT

ADVANCED  
BUILDINGS

ADVANCED  
SUPPORT  
VEHICLES

GENERAL  
RULES

ADVANCED  
SUPPORT VEHICLE  
CONSTRUCTION

ADVANCED  
WEAPONS  
AND EQUIPMENT

INDEX

RECORD SHEETS



## ADVANCED SUPPORT VEHICLE ENGINE TABLES

Advanced Support Vehicle Type	Movement Factor
Non-Airship/Non-Rail Support Vehicles	4 + (Desired Cruising MP x Desired Cruising MP)
Rail Support Vehicle	4 + ((Desired Cruising MP - 2) x [Desired Cruising MP - 2])*
Airship Support Vehicle	4 + (Desired Safe Thrust x Desired Safe Thrust)**
Satellite Support Vehicle	1

Flanking MP Value (Non Airship)	Max Thrust Value (Airships)
Cruising MP x 1.5 (round up)	Safe Thrust x 1.5 (round up)**

\*Rail Support Vehicles built to be unpowered railcars need not compute an Engine Weight.

\*\*Airships have a Maximum Safe Thrust of 2 and may choose Thrust Points in multiples of 0.25, rather than whole numbers (round all computed Max Thrusts for Airship units up to the nearest multiple of 0.25); Satellites do not receive a Max Thrust (their engines provide for station-keeping only, at a set 0.1 Thrust).

### ADVANCED SUPPORT VEHICLE ENGINE WEIGHT FORMULAE

Engine Weight = Base Engine Value x Movement Factor x Engine Weight Multiplier x Total Advanced Support Vehicle Weight\*

\*Round up to nearest kilogram for units under 5 tons; for units 5 tons and over, round up to nearest half-ton.

## ADVANCED SUPPORT VEHICLE ENGINE COMPATIBILITIES TABLE

Advanced Support Vehicle Type	Compatibility by Engine Type								
	Steam	ICE	External*	Battery*	Fuel Cell*	Solar*	MagLev	Fission	Fusion
Satellite	N	N	N	Y	Y	Y	N	Y	Y
Rail	Y	Y	Y	Y	Y	Y	Y	Y	Y
Airship	Y	Y	N	Y	Y	Y	N	Y	Y
Naval Vessel	Y	Y	N	Y	Y	Y	N	Y	Y

\*External, Battery, Fuel Cell and Solar engine types are classified as Electric engines. (Externally powered engines require the External Power Pick-Up Chassis Modification).

## ADVANCED SUPPORT VEHICLE ENGINE WEIGHT MULTIPLIERS AND FUEL WEIGHT PERCENTAGE TABLE

Advanced Support Vehicle Engine Type	Engine Weight Multiplier (by Tech Rating)							Fuel: % of Engine per 100 km Range*
	A	B	C	D	E	F		
Steam	4.0	3.5	3.0	2.8	2.8	2.5	3	
Internal Combustion (ICE)	NA	2.0	2.0	1.5	1.3	1.0	1**	
Electric (External)	NA	1.4	1.0	0.8	0.7	0.6	NA	
Electric (Battery)	NA	NA	1.5	1.2	1.0	0.8	5	
Electric (Fuel Cell)	NA	NA	1.2	1.0	0.9	0.7	1.5	
Electric (Solar)†	NA	NA	5.0	4.5	4.0	3.5	NA	
MagLev	NA	NA	0.8	0.7	0.5	0.5	NA	
Fission†‡	NA	NA	1.75	1.5	1.4	1.3	NA	
Fusion†‡	NA	NA	1.5	1.0	0.75	0.5	NA	

\*Large Airships use Large Airship Fuel Table below.

\*\*ICEs running on alcohol or natural gas use 1.5 percent.

†Airship Support Vehicles using these engine types do not require fuel.

‡The minimum weight for Fission engines or Tech Rating C Fusion engines is 5 tons; the minimum weight for any other Fusion engine is 0.25 tons.



## ADVANCED SUPPORT VEHICLE ENGINE TABLE (CONT)

### LARGE AIRSHIP SUPPORT VEHICLE FUEL TABLE

Fuel Weight (kg) per Thrust Point (by Tech Rating)*					
A	B	C	D	E	F
63	38	27	21	18	15

\*Solar-, Fission- and Fusion-Powered Airships require no mass for fuel.

### SATELLITE SUPPORT VEHICLE FUEL TABLE

Satellite Engine Type	Fuel Points (per ton)	Strategic Fuel Use (tons/burn day)
Electric (Solar) and Fission	NA	0.043
Fusion	NA	0.005

15-ton Rail Support Vehicle attempting to use a Fission engine with a calculated weight of 3.9 tons may “inflate” the engine’s weight to 5 tons without changing its performance.

**Tractor/Trailers:** Advanced Support Vehicles built as Trailers (those constructed using the Trailer chassis modification, including railcars), do not require an engine or control systems unless they are also expected to operate without a suitable Tractor unit. The movement rate of any Tractor/Trailer Advanced Support Vehicle combinations is based on that of the controlling Tractor unit, and is subject to the rules for carrying external cargo as presented in *Total Warfare* (see p. 261, *TW*), or the appropriate rules for Rail Vehicle movement (see p. 149 of this book).

**Flat Cars:** Rail vehicles without engines or other components may be designated as either “box cars” or “flat cars”. Flat cars may not be armored nor may they receive environmental sealing, and carry all cargo externally (but may subtract any of the car’s unused weight from that of the cargo or units being transported—to a minimum transported tonnage of 0).

**Tech Base/Rating:** The engine types and Tech Ratings presented in this section are available to advanced Support Vehicles made using either the Clan or Inner Sphere tech bases. Advanced Support Vehicles created under either technology base may not make use of the combat engines shown on the Master Engine List in *Total Warfare*, including Compact, Light and XL Fusion engines.

**Space:** The types of engines used by Advanced Support Vehicles do not affect the unit’s equipment slot space.

**Advanced Support OmniVehicles:** Engine type, Tech Rating, movement points and weight must be established when designing an advanced Support OmniVehicle’s base configuration, and may not be altered in the completed Primary or Alternate configurations of that advanced Support OmniVehicle.

According to the engine compatibility tables, Eric’s Starcomm satellite can only use electric engines of Battery, Fuel Cell or Solar types, a Fission engine or a Fusion engine. He opts to use an Electric (Solar) Engine system. As a Medium-size

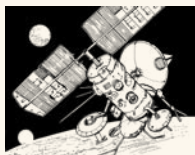

Satellite, its Base Engine Value is 0.10. Because it is a Satellite, it receives an automatic Movement Factor value of 1, as its engines are only used for station-keeping. Using the same Tech Rating for the 20-ton Starcomm’s engine as for its structure (Tech Rating E), Eric finds that the Satellite’s engine weight will be 8 tons in all ( $0.10 \times 1$  [Movement Factor]  $\times 4.0$  [Tech E Solar Engine Multiplier]  $\times 20$  tons = 8 tons).

Combined with its 2.5-ton chassis, the Starcomm now has 9.5 unspent tons remaining ( $20 - 2.5$  [Structure]  $- 8$  [Engine] = 9.5 tons).

For the primary tractor of his Adelante train, Frank has already assigned 216 of the vehicle’s 600 tons to its chassis, leaving 384 unspent tons to go ( $600 - 216 = 384$ ). The Adelante’s Omni railcar meanwhile has 104.5 unspent tons remaining ( $120 - 15.5 = 104.5$ ). Because the Adelante’s primary tractor unit is the motivator for the entire train, Frank must install an engine there, but decides that the railcars will not require engines themselves.

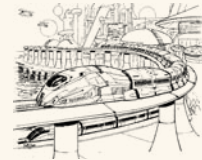

With a Base Engine Value of 0.005, and any engine type desired available to it, Frank provides the Adelante’s primary tractor with a Tech D-rated fusion engine for maximum efficiency. He wants the Adelante to be fast, and assigns it a speedy Cruising Rating of 12, which provides for a Movement Factor of 104 ( $4 + [(12 \text{ Cruising} - 2) \times (12 \text{ Cruising} - 2)] = 104$ ) and a Flanking MP of 18 ( $12 \text{ Cruising MP} \times 1.5 = 18 \text{ Flanking MP}$ ). This means that the Adelante’s primary tractor unit will have a final engine weight of 312 tons ( $0.005$  [Base Engine Value]  $\times 104$  [Movement Factor]  $\times 1$  [Tech D Fusion engine]  $\times 600$  tons = 312 tons). This leaves 72 unspent tons on the Adelante’s tractor ( $384$  unspent tons  $- 312$  engine tons = 72).

Because he has chosen not to install engines on the Adelante’s Omni railcars, Frank proceeds to the next step.

George’s 1,000-ton Cloud Nine has a Base Engine Value of 0.012. He wishes to provide it with a Safe Thrust Rating of 1, which works out to a Movement Factor of 5 ( $4 + [1 \text{ Safe Thrust} \times 1 \text{ Safe Thrust}] = 5$ ), and a Max Thrust of 2 ( $1 \text{ Safe Thrust} \times 1.5 = 1.5 \text{ Max Thrust, round up to } 2$ ). George decides to employ a Fusion engine with a Tech Rating of E (Engine Multiplier 0.75). He thus computes that the engine will weigh 45 tons ( $0.012$  [Base Engine Value]  $\times 5$  [Movement Factor]  $\times 0.75$  [Tech E Fusion Engine Multiplier]  $\times 1,000$  tons = 45 tons). Combined with the Airship’s 255-ton chassis, this leaves 700 unspent tons remaining ( $1,000$  tons  $- 255$  [Chassis]  $- 45$  [Engine] = 700).



For his Jormungand, Henry has a Base Engine Value of 0.009, and wants to provide it a fast Cruising MP of 6 (for a Movement Factor of 40 [ $4 + (6 \text{ Cruising MP} \times 6 \text{ Cruising MP}) = 40$ ] and a Flanking speed of 9 MP ( $6 \text{ Cruising MP} \times 1.5 = 9 \text{ Flanking MP}$ ). Intending this vessel for long voyages on the open seas, he selects a Fusion engine with a Tech Rating of C (1.5 Engine Multiplier). This gives the

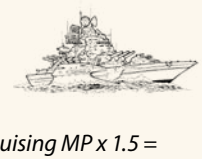

INTRODUCTION

ADVANCED GROUND MOVEMENT

ADVANCED COMBAT

ADVANCED BUILDINGS

ADVANCED SUPPORT VEHICLES

GENERAL RULES

ADVANCED SUPPORT VEHICLE CONSTRUCTION

ADVANCED WEAPONS AND EQUIPMENT

INDEX

RECORD SHEETS



*Jormungand* a final engine weight of 32,400 tons (0.009 [Base Engine] x 40 [Movement Factor] x 1.5 [Tech C Fusion engine] x 60,000 tons = 32,400 tons).

Henry notes that the *Jormungand's* 17,595-ton structure, combined with its 32,400-ton engine, leaves 10,005 unspent tons remaining (60,000 – 17,595 [Structure] – 32,400 [Engine] = 10,005).

## DETERMINE FUEL CAPACITY

Most of the units and engine types featured in these rules have significant fuel requirements. For most advanced Support Vehicles, this fuel capacity is generally expressed as an operating range for the unit, which is computed based on the engine type and the desired operating range (as shown in the Fuel column in the Advanced Support Vehicle Engine Table). Airships, some Satellites and all advanced aerospace units employ Fuel Points instead, as a more abstract means of tracking fuel use. Even though fuel is not typically tracked in *Total Warfare* game play, all advanced units that require fuel must allocate some weight—in addition to their engines—to internal fuel supplies.

**Rail and Naval Advanced Support Vehicle Fuel:** For the Rail and Large Naval Support Vehicles featured in these rules, fuel weight is computed in the same manner used by most standard Support Vehicles: multiplying the desired range (in hundreds of kilometers) by the listed percentage of the unit's engine weight. This figure is rounded up to the nearest kilogram for Small Support Vehicles, or up to the nearest half-ton for advanced Support Vehicles weighing 5 tons and up. For example, a Medium Rail unit with a 32-ton fuel cell engine and a desired operating range of 500 kilometers would add 2.5 tons of fuel to its design (32 tons [engine weight] x 0.015 [1.5 percent per 100 km for fuel cells] x 5 [hundreds of kilometers desired; 500 ÷ 100 = 5] = 2.4 tons, rounded up to 2.5 tons).

Designers interested in a more exact measure of fuel capacity may also re-compute the vehicle's range based on the fuel's final weight (after rounding). To accomplish this, first determine the percentage of the engine mass the fuel weight represents (divide the fuel weight by the engine weight and multiply the result by 100 to find the percentage). Next, divide this percentage by the percentage of fuel weight needed per 100 kilometers of range, and multiply the result by 100 kilometers (rounding down). The final result is the number of kilometers the Support Vehicle can travel on a single full tank of fuel. For instance, if a Steam engine (which requires 3 percent of engine mass in fuel tanks to achieve a 100-km range) weighs 300 kilograms, and its fuel tanks weigh 12 kilograms, the percentage of its fuel weight to its engine weight is 4 ([300 kg ÷ 12 kg] x 100 = 4 percent). At 4 percent of fuel weight (relative to the engine), the vehicle may travel 133 kilometers on a full tank ([4 percent ÷ 3 percent per 100 km] x 100 km = 133.33 km, rounded down to 133).

**Large Airship Support Vehicle Fuel:** Airships and Fixed-Wing Vehicles, which burn fuel by Thrust Points, use a different method of computing fuel weight. For these Support Vehicles, the weight of each "Fuel Point" (in kilograms) is shown (for each Tech Rating of the unit's engine) on the Large Airship Support Vehicle Fuel Table. These points, however, only apply if the Large Airship is powered by Steam, Internal Combustion, Battery or Fuel Cell engine types. Airship Support Vehicles powered by Solar, Fission or Fusion engine types require no Fuel Points at all.

The total weight of all Fuel Points for Airship Support Vehicles must be rounded up to the nearest kilogram for Small units, and up to the nearest half-ton for units 5 tons and up.

**Satellite Support Vehicle Fuel:** Though all Satellites employ some kind of station-keeping drive units incorporated with their engines, they may or may not require fuel based on their intended area of operation. Satellites meant to be placed in a fixed "natural" orbit around a stellar or planetary body (such as a planet, moon or star) effectively take advantage of natural forces to maintain their orbits, and use low-powered ion thrusters to make miniscule corrections as needed. These satellites require no fuel.

Satellites intended for deeper-space operations (such as the zenith and nadir jump points within a system, which are not orbital, but stationary), require either a reserve of station-keeping fuel or a Light Sail (see p. 323). Station-keeping fuel for all such Satellites 200 tons and under burns at a rate of 43 kilograms (0.043 tons) per day on fission- and solar-powered satellite types (see the Advanced Aerospace Unit/Satellite Fuel Table), while fusion-powered Satellites burn fuel at a rate of 5 kilograms (0.005 tons) per day. Station-keeping fuel may be installed on a Satellite Support Vehicle in increments of "burn days" rather than Fuel Points, but the total fuel reserve must be rounded up to the nearest kilogram for Small-sized Satellites, or up to the nearest half-ton for Satellites 5 tons and up. Satellites—unlike advanced aerospace units—also do not require additional weight for pumps (the weight is considered part of the satellite's engine).

Satellites placed in non-fixed "natural" orbits, which do not carry station-keeping fuel or Light Sails, can only maintain their position for 2 days if powered by an Electric (Solar) or Fission engine, or 10 days if powered by a Fusion engine type. Any other Satellite Support Vehicle without a fuel reserve or Light Sail will immediately begin falling toward the local star.

**Tech Base/Rating:** Fuel tanks and fuels are standardized, and equally available to advanced Support Vehicles of Clan or Inner Sphere technology bases, but any Fuel Points installed in Airship Support Vehicles must always match the Technology Rating and size class used to compute the unit's engine weight. (For example, a Large Airship's Tech D-Rated IC engine may not use fuel points reserved for a Tech F engine.)

**Space:** The internal fuel tanks covered by these rules occupy no weapon or equipment slots on any advanced units.

**Advanced Support OmniVehicles:** The fuel capacity installed with an advanced Support OmniVehicle's engine must be established when designing the advanced Support OmniVehicle's base configuration, and may not be altered in the completed Primary or Alternate configurations of that unit (though some units may have access to pod-mounted external fuel tanks).

*Because he plans to deploy his Starcomm satellites in natural planetary orbits exclusively, Eric chooses not to assign any weight to station-keeping fuels, retaining the unit's 9.5 unspent tons for later use.*

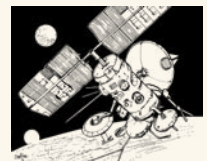

*Because his Adelante's primary tractor uses a Fusion engine, and the railcars employ no engines, Frank also need not assign fuel to his advanced Support Vehicle.*

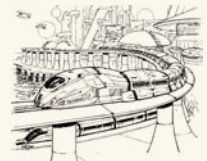



The *Cloud Nine* airship would only have needed to install fuel (in Fuel Points) if it had come with a Steam, Internal Combustion, Fuel Cell or Electric-Battery engine. As George chose to employ a Fusion engine, however, the vehicle requires no fuel.

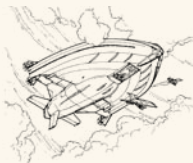

Henry's *Jormungand* also employs a Fusion engine, and so requires no fuel. Had he chosen a fuel-burning engine, he would have needed to determine the vessel's planned operating range first (either in multiples of 100 kilometers, or by assigning weight equal to some percentage of the *Jormungand*'s engine mass and determining the range such a percentage provides).



### DETERMINE STRUCTURAL INTEGRITY (AIRSHIPS ONLY)

Once the weight and Thrust Points of a Large Airship Support Vehicle are determined, designers of this unit type can determine their Structural Integrity (SI) values. This determines the overall strength of the unit's internal structure.

**Airships:** The Structural Integrity Value for an Airship Support Vehicle must equal the Airship's Safe Thrust Rating or 2 percent of the Airship's weight in tons (rounded down), whichever value is higher. This value may not be increased once the Airship's weight and Thrust Points are established; however, regardless of the value, an Airship's SI does not cost any additional weight (as it is considered part of the unit's chassis and armor design).

**Space:** Airship structural integrity does not affect the amount of internal equipment space available to the advanced Support Vehicle.

**Advanced Support OmniVehicles:** The Structural Integrity Value of a Large Airship Support Vehicle built as an Omni is fixed once established for the unit's base configuration. These values may not change between the advanced Support OmniVehicle's base, Primary or Alternate configurations.

Because George's *Cloud Nine* is an Airship, it receives a Structural Integrity (SI) Value at this stage, in place of the internal structure value found on most other vehicle types. Given the unit's Safe Thrust of 1, and its weight at 1,000 tons, George determines that the *Cloud Nine* will receive an SI of 20 (because 2 percent of 1,000 tons is 20, which is greater than the unit's Safe Thrust value). On the record sheet, George blacks out all but 20 circles in the gray-shaded Structural Integrity area at the center of the airship's Armor Diagram.



### ADD LIFT/DIVE EQUIPMENT

Advanced Support Vehicles incorporate any lift or dive equipment into their chassis modification weights, rather than computing them as a separate component. Advanced Support Vehicle designers thus need not assign weight or space to this equipment.

### DETERMINE JUMP CAPABILITY

As with Combat Vehicles and standard Support Vehicles, advanced Support Vehicles built under these rules may not possess jump capability and so cannot mount jump jets of any kind.

### ADD CONTROL/CREW SYSTEMS

Technically speaking, the chassis of all Advanced Support Vehicles contain basic control systems, but some units must still allocate additional mass to crew accommodations and fire-control systems (if installed).

**Crew:** With the exception of Satellite Support Vehicles and certain Rail Support Vehicles—which may, at the designer's option, be constructed as unmanned units—all advanced Support Vehicles require a certain amount of crew to operate them. To determine the basic crew needs for each vehicle type, consult the Advanced Support Vehicle Minimum Crew Table below. An advanced Support Vehicle's crew must be equal to (or, at the designer's option, greater than) the sum of its minimum crew requirements (including any supplemental crew such as officers and those needed to man special equipment such as weapons, communications, kitchens and MASH theaters). Bay personnel—for vehicle bays and such—are not listed (the bays themselves incorporate a limited amount of bunk space for such personnel). The additional crew needs for the specific items listed do not have to be met unless and until the items are mounted (typically after Step 5), and any officer requirements must be computed after all crew is assigned.

Gunners are necessary only for items that require a Gunner Skill roll to use in combat, and that have a range of more than 1 hex. (Automatic defensive armaments like Anti-Missile Systems, A-Pods and the like require no gunners, nor do non-weapon items listed on the Weapons and Equipment Tables, such as Active Probes and ECM gear.)



Davion Guards' Mechs welcome the arrival of much needed fire-support.

INTRODUCTION

ADVANCED  
GROUND MOVEMENT

ADVANCED  
COMBAT

ADVANCED  
BUILDINGS

ADVANCED  
SUPPORT  
VEHICLES

GENERAL  
RULES

ADVANCED  
SUPPORT VEHICLE  
CONSTRUCTION

ADVANCED  
WEAPONS  
AND EQUIPMENT

INDEX

RECORD SHEETS



Satellite Support Vehicles and Rail units built as trailers without engine systems are a noteworthy exception because they may be built as unmanned units instead. For such units, a minimum Base Crew of 0 applies (though the units receive no weight credit for this, as any saved weight for life support and control systems would then go into automation). Satellites may be unmanned as long as they employ no weapons, MASH facilities, field kitchen units or any other crew-served equipment aside from communications gear. Railcars (Rail units built as trailers with no engines) may take on crew if they mount any crew-served items.

**Crew Accommodations:** For Small-sized advanced Support Vehicles, the designer must allocate weight to seating (standard, pillion or ejection-capable) or to appropriate infantry compartment/bays for all crew and passengers, including their minimum personnel. All other advanced Support Vehicles 5 tons and over integrate seating automatically for the minimum required crewmen, but still require appropriate compartments/bays (or even quarters) for passengers such as infantry, or for any crew added beyond the minimum. Bay personnel—those required for vehicle bays, 'Mech bays and so forth—incorporate a limited amount of seating and/or bunk space into their design, and so need not be counted toward

required accommodations. (However, "bay bunks," especially infantry bay accommodations, are even worse than steerage quarters and generally meant for short flights. Designers with a generous weight budget may consider supplying quarters for individual MechWarriors, fighter pilots or even infantry personnel.)

Large-sized Airships and Naval Vessels, which are designed to spend days of operation away from any ports of call, provide quarters—rather than mere crewman seating—as part of their design. These units thus require additional tonnage spent on quarters only for crew and passengers established *beyond* their minimum requirements. Other advanced Support Vehicle types may add quarters, but must pay for *all* of them, as these exceed the minimalist seating provided for by the design.

Satellites with no crew requirement or Rail trailers built without crew requirements do not require quarters (though such should be added if the unit is to carry passengers, or incorporates items that require crewmen, such as weapons, MASH units, field kitchens and non-Satellite communications gear).

**Fire Control Systems:** Designers of advanced Support Vehicles that are to be armed may wish to allocate additional weight to fire-control systems in order to reduce the crew's need for all mounted

## ADVANCED SUPPORT VEHICLE MINIMUM CREW TABLES

### Minimum Crew Formula:

Minimum Crew Needs = Base Crew Minimum + Non-Gunner  
Minimum Crew + Minimum Gunners + Minimum Officers

Advanced Unit Type	Base Crew Minimum
Rail/Satellite Support Vehicles (Small)	1
Rail/Satellite Support Vehicles (Medium)	2
Rail/Satellite Support Vehicles (Large)	3
Airship Support Vehicles (Large)	3 + (1 per 500 tons)*
Naval Support Vehicles (Large)	3 + (1 per 5,000 tons)*
Support Vehicle constructed as a Trailer with no Engine	0**
Support Vehicle constructed as Unmanned Satellite	0**

\*Round up

\*\*Trailer and Satellite Base Minimum supersedes any Base Minimum established for other Support Vehicle types

### ADDITIONAL CREW

Non-Gunners	Minimum Crew Requirement
Communications Equipment (per ton, see p. 213, <i>TM</i> )	1*
Field Kitchen (per item, see p. 217, <i>TM</i> )	3
Flight Deck (per item, see p. 312)	20
Helipad (per item, see p. 312)	5
MASH (per theater, see p. 228, <i>TM</i> )	5
Mobile Field Base (per item, see p. 330)	5

\*Unmanned Satellites need not assign crew to Communications Equipment; All other items listed above always require crew

Officers	Minimum Officer Requirement
1 to 4 Non-Officer Crew	0
5 or more Non-Officer Crew	Total Non-Officer Crew ÷ 5 (round up)

Gunners	Minimum Gunners (by Fire Control System)*		
	None (+2 to-hit)	Basic (+1 to-hit)	Advanced (+0 to-hit)
Per Light Weapon (see p. 20, <i>TM</i> )	1	1	1
Per Medium Weapon (see p. 20, <i>TM</i> )	Half Crew**	1†	1‡
Per Heavy Weapon (see p. 20, <i>TM</i> )	Weapon Tons ÷ 3**	Weapon Tons ÷ 3**	Weapon Tons ÷ 3**

\*Gunners are required only for items that require a Gunnery Skill roll to use in combat; Unmanned Satellites may not be armed

\*\*Round up; Medium (Support) Weapon crew requirements are listed in Conventional Infantry Weapons Table, p. 349, *TM*.

†May not include the vehicle's driver/pilot

‡May include the vehicle's driver



weapons. The impact on crew requirements for installing such fire-control systems will affect the unit's crew requirements and so is shown under the Gunners section of the Advanced Unit Minimum Crew Table, but these values need not apply unless the designer chooses to mount weaponry. Because fire-control system weights are directly related to the weight of the weaponry mounted on an advanced Support Vehicle, the designer may feel free to determine the weight of fire-control systems after installing any mounted weapons and ammunition (in Step 5). However, for the purposes of assigning crews or when designing advanced Support OmniVehicles, it is important to establish whether or not the vehicle will be using such systems at this time.

**Tech Base:** The control systems and crew accommodations covered by these rules are equally available to advanced Support Vehicles built using a Clan or Inner Sphere technology base.

**Advanced Support OmniVehicles:** The minimum seating, quarters and fire-control systems, once established for an advanced Support OmniVehicle's base configuration, may not change between its base, Primary or Alternate configurations. Because the weight of any fire-control system is directly tied to the weight of the weapons mounted on the advanced Support Vehicle, this weight determines how much pod space may be devoted to weaponry. Additional quarters may be installed beyond these requirements, however.

*Eric plans for his Starcomm to operate as an unmanned communications satellite, and so establishes a base minimum crew need of 0. Thus, there is no immediate need for crew quarters or seating of any kind on the satellite. However, Eric also may not mount weapons, MASH units, passenger quarters, field kitchens or anything else with a defined crew requirement on this unit except for Satellite-based communications gear. This is just fine by him.*

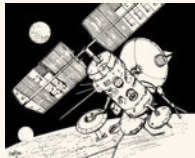

*The primary tractor unit for Frank's Adelante is a Large-size Rail unit with an engine, and so has a minimum crew requirement of 3. While Frank could just as easily go with the 3 seats that come free with the Adelante's chassis, he decides to add 5 standard crew quarters to the design as well, to provide comfort for the crew in the event his advanced Support Vehicle is called upon for extended travel. Because quarters are not required for a Rail unit, these quarters occupy 7 tons each—for a total of 35 tons—and take up 1 equipment slot (5 crew quarters ÷ 20 crew quarters per slot = 0.25, round up to 1 slot). This leaves the Adelante's primary tractor unit with 37 tons left over (72 tons – 35 quarters tons = 37 tons).*

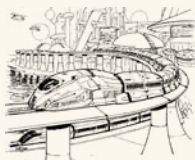

*The railcars, on the other hand, are built as Medium-sized, engine-less trailers, and thus have no crew quarters requirements. For the Adelante's Omni railcars, Frank thus decides to install no quarters at this time. This will leave the current 104.5 unspent tons.*

*As an Airship weighing 1,000 tons, George's Cloud Nine receives a base minimum crew of 5 (Base Crew = 3 + [1,000 tons ÷ 500] = 5). Because there are already 5 crewmen, George must also add an officer (5 crew ÷ 5 = 1 officer). Anticipating more crewmen to man on-board systems he has yet to assign, George holds off computing his full crew complement and accommodations at this time. Even so, he bears in mind that quarters for the Airship's minimum crew needs will be provided weight-free as part of the unit's design.*

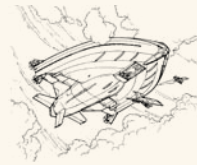

*Henry's Jormungand will also receive quarters for its minimal crew needs at no cost in weight or slot space, but—like George—Henry has yet to add equipment, which may increase the cruiser's basic needs. He can, however, establish the Jormungand's base crew needs and officers at this stage. For base crew, the 60,000-ton cruiser has a crew requirement of 15 (3 + [60,000 tons ÷ 5,000] = 15), which requires an additional 3 officers (15 crew ÷ 5 = 3).*



## SPECIAL ENHANCEMENTS

Under these rules, any special physical enhancements—such as Environmental Sealing, hydrofoil capability and so forth—are already incorporated into the design of the advanced Support Vehicle's chassis. Advanced Support Vehicles have no add-on equivalents to the MASC or Triple-Strength Myomer systems that BattleMechs may employ.

# STEP 3: ADD HEAT SINKS

Advanced Support Vehicles handle heat differently than BattleMechs. Like Combat Vehicles, they only require heat sinks if they mount heavy energy weapons. If such energy weapons are mounted, however, the number of heat sinks required by the unit equals the total amount of heat generated by firing all such energy weapons simultaneously. This applies to all advanced Support Vehicle types, even those that function as aerospace units (such as Airships and Satellites).

Though determining a unit's heat sink needs is dependent on many factors, this stage can help provide advanced Support Vehicle designers with a guide toward determining how many heat sinks the unit initially receives (if any), as well as preparing the unit in advance for a desired selection of weapons. Alternatively, the designer may wish to skip this step until after all weapons and equipment are selected, in order to better allocate the unit's remaining tonnage.

Unlike Combat Vehicles and other units, advanced Support Vehicles receive no "weight-free" heat sinks, regardless of the engine and chassis types chosen. Any shielding and cooling capability they do have covers only the needs of the engines themselves.

INTRODUCTION

ADVANCED  
GROUND MOVEMENT

ADVANCED  
COMBAT

ADVANCED  
BUILDINGS

ADVANCED  
SUPPORT  
VEHICLES

GENERAL  
RULES

ADVANCED  
SUPPORT VEHICLE  
CONSTRUCTION

ADVANCED  
WEAPONS  
AND EQUIPMENT

INDEX

RECORD SHEETS



**Tech Base:** Standard (single) heat sinks are the only type available to advanced Support Vehicles of any tech base.

**Space:** An advanced Support Vehicle's heat sinks do not affect the amount of weapon slots available to the unit.

**Advanced Support OmniVehicles:** Advanced Support OmniVehicles of Clan or Inner Sphere design may add more heat sinks at this stage, or none. Additional heat sinks for later configurations may be mounted in Omni-pods as with other weapons and equipment, but at a cost in weight only (not item space). Such additional sinks may then be easily determined by the vehicle's configuration, based on its chassis and the total heat of all energy weapons on that base configuration.

*As Eric already determined that his Starcomm will not carry any heavy energy weapons, and thus will generate no heat from their use, he chooses to install no heat sinks at this time.*

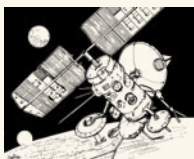

*The main tractor for Frank's Adelante, he decides, also will not carry heavy energy weapons, and so he elects to install no heat sinks at this time. He also sees no need to install fixed heat sinks on the Adelante's Omni railcars.*

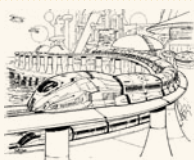

*George also believes his Cloud Nine Airship will not carry heavy energy weapons, and thus requires no heat sinks at this time.*



*Because he plans for his Jormungand to serve in combat, Henry decides that at least some of its weaponry will include heavy energy weapons. For now, he decides to install 40 heat sinks (at 1 ton each, for 40 tons in all) on this vessel, leaving a total of 9,965 unspent tons remaining (10,005 - 40 = 9,965 tons). As the Jormungand is a Support Vehicle, it may only employ standard (single) heat sinks.*



The BAR values reflect the variety of armor types open to advanced Support Vehicles, and is used to determine whether or not heavy weapons fire penetrates the unit's protection despite the points remaining in the location. In *Total Warfare* tournament game play, if a unit has a BAR of less than 10, any damage sustained in a single hit that exceeds the BAR may inflict a Penetrating Critical Hit (see p. 206, *TW*).

The maximum number of armor points an advanced Support Vehicle may receive is shown in the Maximum Armor column of the Advanced Unit Armor Maximums Table. This value is always rounded down to the nearest whole number and applies to Clan and Inner Sphere advanced Support Vehicles, regardless of the Tech Rating used, and is established in points (rather than tons).

Regardless of the BAR, Tech Rating or tech base applicable to the armor used, the unit may not exceed its listed maximum armor capacity. Remember, however, that these values reflect the selected unit's maximum *total* armor capacity; the number of points per location is left up to the designer. Advanced Support Vehicles designed with the Armored, Amphibious, Environmental Sealing or Submersible chassis modifications have a minimum armor requirement of 1 point per location.

Advanced Support Vehicle armor may be mounted in kilogram lots for Small-sized Support Vehicles, but all advanced units weighing 5 tons or more must round all armor weights up to the nearest half-ton. Advanced Support Vehicle armor may be purchased in points or in tons using the Advanced Support Vehicle Armor Weights Table, which provides the weight (in kilograms) for each point of armor at each BAR and Tech Rating. To find the tonnage of a given amount of armor on an advanced Support Vehicle weighing 5 tons or more, simply divide the kilogram weight for the total desired number of armor points by 1,000 and round the result up to the nearest half-ton.

Using the Armor Diagram on the advanced Support Vehicle's appropriate Record Sheet, mark out any excess armor circles to indicate the number of armor points that protect each part of the unit's body. Armor circles for a given location are located in the appropriate unshaded parts of the diagram.

Under these rules, designers may not mix armor types on an advanced Support Vehicle, and may only use armor types listed in the Advanced Support Vehicle Armor Table.

**Tech Base/Rating:** The Tech Rating of the armor chosen for an advanced Support Vehicle may not exceed that of its chassis. Also, armor at some BAR levels may not be available to an advanced Support Vehicle unless it possesses the Armored chassis modification. (An entry of NA on the Advanced Support Vehicle Armor Table means that armor of a given BAR does not exist for Support Vehicles at that Tech Rating.)

**Space:** Under these rules, no armor type available to advanced Support Vehicles reduces their equipment slot space.

**Advanced Support OmniVehicles:** The type of armor, its weight, number of points and their allocation must be established when designing the base configuration of an advanced Support

## STEP 4: ADD ARMOR

Most advanced Support Vehicles—whether built as unarmed Rail Vehicles or as massive seagoing battle cruisers—use some kind of armor to protect their internal structures and critical components against the elements, routine wear and tear, and combat. This armor varies wildly with the vehicle's tech base, weight and the relative strength of the armor chosen (defined as the armor's Barrier Armor Rating, or BAR).

### ADVANCED SUPPORT VEHICLE HEAT SINKS TABLE

Unit Type	Min. Heat Sink Requirement	Weight-Free Heat Sinks
Advanced Support Vehicles (All)	Total of all Heavy Energy Weapon Heat	0



## ADVANCED SUPPORT VEHICLE ARMOR TABLES

### ADVANCED SUPPORT VEHICLE ARMOR MAXIMUMS

Unit Type	Maximum Armor (Points)*	Armor Facings
Rail and Satellite (Small/Medium)	4 + (0.5 per ton)	Nose, Left, Right, Aft**
Rail (Large)	4 + (0.5 per ton)	Nose, Fore-Left, Fore-Right, Aft-Left, Aft-Right, Aft**
Satellite (Large)	4 + (0.5 per ton)	Nose, Left, Right, Aft
Large Airship	89 + (0.05 per ton)	Nose, Left, Right, Aft
Large Naval	89 + (0.05 per ton)	Front, Front-Left/Right, Rear-Left/Right, Rear**

\*Round down to nearest whole point or half-ton.

\*\*Rail and Naval units may add Turrets if desired.

### ADVANCED SUPPORT VEHICLE ARMOR WEIGHTS

Barrier Armor Rating (BAR)	Weight (in kg) per Armor Point (by Tech Rating)					
	A	B	C	D	E	F
2	40	25	16	13	12	11
3	60	38	24	19	17	16
4	80	50	32	26	23	21
5	100*	63	40	32	28	26
6	130*	75*	48	38	34	32
7	180*	88*	56*	45	40	37
8	230*	120*	64*	51*	45	42
9	NA	180*	100*	57*	51*	47
10	NA	250*	150*	63*	56*	52*

\*The Armored chassis modification is required to install this armor on a chassis of this Tech Rating.

OmniVehicle. These values may not be altered in the completed Primary or Alternate configurations of that OmniVehicle.

At 20 tons, Eric finds that his Starcomm Satellite can only support 14 points of armor in all (4 + [20 tons x 0.5 points per ton] = 14 points). While he plans to protect the unit nevertheless, Eric has not opted for an Armored chassis modification, and decides upon a modest BAR of 5 for the Starcomm. At a Structural Tech Rating of E, each point of armor will weigh 28 kilograms (0.028 tons). Maximizing the armor, Eric installs 14 points, placing 4 each in the Starcomm's Nose and Aft facings, and 3 each in the Left and Right facings. These 14 points cost 0.5 tons in weight (14 points x 0.028 tons per point = 0.392 tons, round up to 0.5), leaving 9 unspent tons available for his satellite (9.5 - 0.5 = 9).

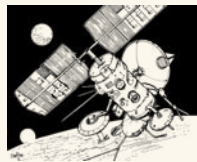

For the Large-size 600-ton main tractor of Frank's Adelante, the maximum armor factor possible is 304 points (4 + [600 tons x 0.5 points per ton] = 304). Though the unit does not feature the Armored chassis modification, he decides to give it a tough skin to deal with possible collisions (or the odd well-armed raider), and so goes with a BAR of 7 (which also happens to be the toughest armor BAR he can get at his unit's Tech Rating of D without having an armored chassis). This armor will weigh 45 kilograms (0.045 tons) per point, and Frank decides on a nice round 200 points to protect the Adelante's tractor unit. This armor weighs 9 tons in all (200 points x 0.045 tons per point = 9 tons), leaving the train engine with 28 unspent tons (37 - 9 = 28). Frank allocates 40 points to the tractor unit's Front facing, 35 each to the Front-Side and Rear-Side facings, and the remaining 20 to the Rear facing.

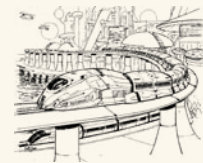

INTRODUCTION

ADVANCED  
GROUND MOVEMENT

ADVANCED  
COMBAT

ADVANCED  
BUILDINGS

ADVANCED  
SUPPORT  
VEHICLES

GENERAL  
RULES

ADVANCED  
SUPPORT VEHICLE  
CONSTRUCTION

ADVANCED  
WEAPONS  
AND EQUIPMENT

INDEX

RECORD SHEETS



For the smaller, but more advanced 120-ton railcars, Frank notes he has a maximum armor capacity of 64 points ( $4 + [120 \text{ tons} \times 0.5 \text{ points per ton}] = 64 \text{ points}$ ). Once more, the railcars do not feature the Armored chassis modification, but because they were built using a Tech Rating of F, Frank decides to use Tech F armor as well, and finds that the maximum possible BAR for that rating is 9. This armor will weigh 47 kilograms (0.047 tons) per point, and so a maximum armor value will be 3.5 tons ( $64 \text{ points} \times 0.047 = 3.01 \text{ tons}$ , round up to 3.5). Looking to save the half-ton lost to rounding, Frank installs 63 points of armor for 3 tons ( $63 \times 0.047 = 2.96 \text{ tons}$ , round up to 3 tons), leaving the Adelante's railcars with 101.5 unspent tons ( $104.5 - 3 = 101.5$ ). Frank mounts 16 points each in the Medium-sized railcar's Front, Left and Right facings, and 15 in the Rear.

George has decided that his unarmed 1,000-ton Cloud Nine Airship will not require heavy armor as its mission is not one of combat, but merely small aircraft transport and support. He finds, however, that if he wanted to, he could mount up to 139 points of armor on the Large-size Airship ( $89 + [1,000 \text{ tons} \times 0.05 \text{ points per ton}] = 139$ ). Looking to save on armor tonnage, George selects the minimum BAR of 2 for his Cloud Nine's protection, which weighs only 12 kilograms (0.012 tons) per point at the unit's Tech Rating of E. He decides to install 83 points of this armor on the Airship, allocating 23 points to the Nose facing and 20 points to the other three locations (Left, Right, and Aft), spending only 1 ton of weight in the effort ( $83 \times 0.012 = 0.996$ , round up to 1). This leaves the Cloud Nine with 699 unspent tons ( $700 - 1 = 699$ ).

Henry's 60,000-ton Jormungand is intended for combat, and so features an Armored chassis modification. Thus, at its size, the vessel can mount up to 3,089 points of armor ( $89 + [60,000 \text{ tons} \times 0.05 \text{ points per ton}] = 3,089 \text{ points}$ ), which may be BAR 10—the equivalent strength of BattleMech armor, which he will need to divide up among 11 facings (6 hull facings plus 5 turrets). Henry decides to install the maximum of 3,089 points of BAR 10 armor, which will weigh 463.5 tons at the vessel's Tech Rating of C ( $3,089 \text{ points} \times [0.150 \text{ tons per point for Tech C, BAR 10 armor}] = 463.35$ , round up to 463.5 tons). Henry decides to place 304 armor points in the Jormungand's Front facing, 300 points in all five other hull facings (Front-Left, Front-Right, Rear-Left, Rear-Right and Rear), and 257 points in each of the vessel's five turrets).

After subtracting the armor weight, Henry finds his bluewater cruiser will have a total of 9,501.5 unspent tons remaining ( $9,965 - 463.5 = 9,501.5 \text{ tons}$ ).

## STEP 5: ADD WEAPONS, AMMUNITION AND OTHER EQUIPMENT

The weapons, ammunition and equipment that may be mounted on advanced Support Vehicles are listed in the Master Weapons and Equipment Tables beginning on p. 400. In addition to any heat, damage and range statistics, these tables provide the weight these items take up on an advanced Support Vehicle, how many equipment slots they occupy, what technology base (Clan or Inner Sphere) and Tech Rating (A through F) is required to use them, and any special construction rules that might apply to installing the equipment (such as location and unit type restrictions).

Remember that the total weight for a given advanced Support Vehicle's structure, engine, controls, armor, heat sinks, weapons and other components must never exceed the weight established for the vehicle in Step 1. Any leftover weight that cannot be allocated to cargo space or other equipment (due to item slot constraints or other factors) is considered wasted tonnage.

Weapons and items placed in any non-turret location on any advanced Support Vehicle automatically receive a fixed firing arc in that direction (meaning a vehicle's front-mounted weapon will have a front firing arc, while a Large Naval Vessel's left-forward mounted weapon can only fire into the left-forward arc, and so on). Turret-mounted weapons—available under these rules only to certain advanced units such as Rail and Large Naval vehicles—have a firing arc determined by the turret's facing during game play. Advanced Support Vehicle pintle-mounts—which differ from turrets in that they have no separate locations and are mounted more as items in themselves—provide a 180-degree firing arc based on the side of the unit upon which they are mounted.

For special rules on any item, consult its entry under Heavy Weapons and Equipment (pp. 201-251, *TM*, 274-375).

**Tech Manual Items:** The Weapons and Equipment items described and listed in the tables in *Tech Manual* may all be mounted on advanced Support Vehicles in accordance with their standard equipment rules. Advanced Support Vehicles may install any item permitted on tournament-legal Support Vehicles as long as the item has no special rules that preclude its use by such units (such as the use of torpedo LRMs on a Satellite or land-based Rail unit).

**Tech Base/Rating:** The Weapons and Equipment Tables note which items are available to which technology bases. Clan-made advanced units may use only items available to the Clans, while Inner Sphere-made advanced units must use only those items available to the Inner Sphere. Within these limits, items of any Tech Rating may be chosen, but designers of advanced Support Vehicles should remember that the unit's Final Tech Rating—and with it, its final cost—will be determined by its highest-rated component.

**Space:** As with their tournament-legal cousins, advanced Support Vehicles spend a variable number of item slots on each weapon or equipment item based on its statistics provided in the item's entry on the Weapon and Equipment Tables in *Tech Manual* (see pp. 341-345) and in this book (pp. 274-375).





**Weapons:** Small-sized advanced Support Vehicles may only mount Light- and Medium-weight weapons, which are listed in the Infantry Weapons and Equipment Tables found on pp. 350-352 in *TechManual*. For purposes of arming such Support Vehicles, Light weapons are those listed as Standard on the Infantry Equipment Table, while Medium-weight weapons are classed as Support. Regardless of their type, these weapons require no heat sinks, but may carry ammunition in multiples of their magazine size. Both of these weapon types may be mounted in fixed locations, or on pintle and turret mounts.

Under these rules, advanced Support Vehicles weighing 5 tons or more may not mount Light- or Medium-weight weapons, but they may instead mount Heavy weapons, which are represented in the Weapons and Equipment Tables starting on p. 341 of *TechManual*, as well as any appropriate equipment permitted on such units in the Advanced Weapons and Equipment section in this book (starting on p. 404).

Remember that, depending on the number of weapons and types of fire-control systems used, advanced Support Vehicles may require additional crew (and any applicable accommodations) to handle such firepower (see *Add Control/Crew Systems*, p. 249). For these units, Light- and Medium-weight weapons require gunners based on the weapon's Crew value shown in the Infantry Weapons and Equipment Tables in *TechManual*. For Heavy weapons on advanced Support Vehicles, gunners are required only for any item that requires a Gunnery Skill roll to use in combat, and which has a range of more than 1 hex. (Automatic defensive armaments like Anti-Missile Systems, A-Pods, and the like require no gunners, nor do non-weapon items listed on the Heavy Weapons and Equipment Tables, like Active Probes and ECM gear.)

**Ammunition:** All ammo-dependent Heavy weapons—except for machine guns (including their Light and Heavy versions) and nail or rivet guns—require at least a ton of ammunition. (Machine guns, nail guns and rivet guns may carry ammo in half-ton lots instead.)

Slots for the Light- and Medium-sized weapons on Small-sized advanced Support Vehicles are considered to be included with the slot costs for the weapons themselves. For ammo-based Heavy weapons and the ammunition bins on Medium- and Large-sized advanced Support Vehicles, all ammo is presumed to have a Body location, with each bin of ammo occupying 1 slot regardless of the ammo bin's weight. If the Support Vehicle is a multi-hex design, however (such as a Large-size Naval Vessel), ammo must be stored in the Body hexes corresponding to the location where the weapon is mounted—whether or not the weapon is mounted in a turret. This can require that a multi-hex unit with multiple identical weapons will have to spend more slots overall on ammunition to feed the various weapon mounts.

Ammo bins may be of mixed ammunition types, but only if the ammunition feeds the same weapon (so a single 3-ton ATM ammo bin can carry 1 ton each of ER, High Explosive and Standard ATM rounds, but occupies only 1 advanced Support Vehicle slot).

**Heat Sinks:** On advanced Support Vehicles, heat sinks are required only for Heavy energy weapons used by the Support Vehicle, and the number of heat sinks required equals the heat value of all such energy weapons fired simultaneously. Medium and Light energy weapons, which represent infantry

combat weapons, do not require sinks when mounted on advanced Support Vehicles.

**Power Amplifiers:** An advanced Support Vehicle not powered by a Fission or Fusion engine may carry Heavy energy weapons such as lasers and PPCs, but to do so, it must also mount power amplifiers. Power amplifiers weigh 10 percent of the weight of the energy weapons carried (rounded up to the nearest 0.1 ton, rather than the nearest 0.5 ton), but take up no equipment slots on the vehicle's Record Sheet. (Medium-weight and Light energy weapons, which represent infantry combat weapons, do not require power amplifiers.)

**Turrets/Pintles:** Of the advanced Support Vehicles presented here, Small- and Medium-sized Rail Support Vehicles may possess one turret at the designer's option, while Large Naval Vessels may possess one turret per hex of vessel length (to a maximum of 8 turrets per unit). The mass of such turrets must equal at least 10 percent of the weight of all weapons and equipment (excluding ammunition) mounted within. This weight must be rounded up to the nearest kilogram for Small-sized vehicles, or to the nearest half-ton for advanced Support Vehicles 5 tons and up. Turrets count as an extra section on the advanced Support Vehicle's Record Sheet, each requiring its own internal structure and armor.

Pintles—available under these rules to Small-sized Rail Support Vehicles—may mount only Light and Medium weaponry. The weight of a pintle mount is equal to 5 percent of the weight of all weapons and equipment mounted within it (rounded to the nearest kilogram). Pintles do not count as separate locations and do not receive internal structure or armor. They must be mounted instead in side locations (Left, Right, Front or Rear).

Satellite and Airship advanced Support Vehicles may not mount turrets or pintles.

**Small Items on Medium and Large Advanced Units:** Several items that may be installed on advanced units of 5 tons and up in total weight have item weight values presented in kilograms rather than tons. When mounting such items, the designer must keep a running total of the number of kilograms used. At the end of this step in the design process, divide this quantity of kilograms by 1,000 to find their total weight in tons. The final result must be rounded up to the nearest half-ton.

If space is available for cargo on an advanced Support Vehicle, this can also be accomplished by allocating any "loose" kilograms to cargo, so a 100-ton unit that comes to 96.36 tons because of small items may simply add a 3.64-ton (3,640-kilogram) cargo bay to reach an even 100 tons.

**Support OmniVehicles:** Though it is unusual, weapons and equipment may be established as fixed components of an advanced Support OmniVehicle's base configuration just like heat sinks, armor and the like. In such cases, these "fixed" items must be mounted and placed among the unit's weapon slots before completing the base configuration, and they may not be altered in the unit's completed Primary or Alternate configurations.

For turret- or pintle-equipped advanced Support OmniVehicles, the tonnage of the turret or pintle(s) may not be changed across configurations. Developing an advanced Support OmniVehicle therefore requires the designer to consider from the start how much weight in equipment (not counting

INTRODUCTION

ADVANCED  
GROUND MOVEMENT

ADVANCED  
COMBAT

ADVANCED  
BUILDINGS

ADVANCED  
SUPPORT  
VEHICLES

GENERAL  
RULES

ADVANCED  
SUPPORT VEHICLE  
CONSTRUCTION

ADVANCED  
WEAPONS  
AND EQUIPMENT

INDEX

RECORD SHEETS



ammunition) may be placed in the turret and/or pintle location(s), so as to establish the weight of the turret and/or pintle(s) for the base, Primary and all Alternate configurations of that unit. As indicated earlier, turrets weigh 10 percent of the weight of all weapons located in the turret. Therefore, the weight of any equipment placed in a turret (discounting ammunition) may be no greater than 10 times the turret's weight. Pintles, which weigh 5 percent of their weapons' weight, may carry no more than 20 times the pintle's weight in items.

**Capital Weapons:** Advanced Support Vehicles may not carry capital weapons under these rules.

**Crew Quarters:** The installation of additional items and weapons on an advanced unit can affect the minimum crew required to man any advanced unit, as can the additional space for any passengers for long-distance transportation. The rules determining a unit's minimum crew needs are found under *Add Control/Crew Systems* (see p. 249). For Small-sized advanced Support Vehicle units, the designer must allocate weight to seating (standard, pillion or ejection-capable) or to appropriate infantry compartment/bays for all crew and passengers, including their minimum personnel. All Support Vehicles 5 tons and over automatically integrate seating (or quarters, in the case of Large Naval and Large Airship units) for the minimum required crewmen, but will still require appropriate compartments/bays (or even quarters) to be added for passengers such as infantry, or for any crew added beyond the minimum.

Bay personnel—which includes personnel associated with other units being transported, such as infantry, vehicles, fighters and 'Mechs—need not be allocated quarters, as their bays already incorporate basic amenities. Additional quarters for such personnel may be added as passenger quarters, reflecting an added level of comfort and support, but are not required.

**Fire Control Systems:** In addition to crew quarters, designers of armed advanced Support Vehicles may wish to allocate weight for fire-control systems to reduce the crew's need for all mounted weapons. The impact on crew requirements for installing such fire-control systems is also shown on the Advanced Support Vehicle Crew Requirements Table, but these need not apply unless the designer chooses to mount weaponry. Because fire-control system weights are directly related to the weight of the weaponry mounted on a Support Vehicle, the designer may feel free to determine the weight of fire-control systems after installing any mounted weapons and ammunition, though in some cases—such as the design of Support OmniVehicles—it may be important to establish that the vehicle will be using such systems first.

**Transport Bays and Doors:** Bays for cargo and unit transport often make up all remaining tonnage on advanced units of every stripe. These bays can be specific cubicles for 'Mechs, fighters and other units, or they may be generic cargo bays to store supplies, spare parts or even additional ammunition and fuel stores. How much of the generic cargo space is allocated to such needs is entirely up to the designer and can vary from mission to mission, so they need not be addressed during construction. At the player's discretion, however, any cargo space not specifically allocated as refrigerated or liquid storage may be declared as "flatbed" cargo space, which can be used to transport cargo or units externally (see p. 261, *TW*).

On Small- and Medium-sized advanced Support Vehicles, bay doors are not a requirement for access and egress to such bays, unless the cargo is considered significantly large (1 ton or more—roughly the size of a battle armored trooper, large pack animal or

small vehicle). Large-size Support Vehicles, however, require bay doors for every dedicated transport bay—including those filled with fighter, BattleMech or other unit cubicles.

Designers of Large-sized advanced Support Vehicles must assign a minimum of 1 bay door to any unit with a transport bay, to allow for entry and egress from the unit. To find the maximum total number of bay doors a unit can incorporate, consult the Advanced Support Vehicle Maximum Bay Doors Table below.

Vehicles using "flatbed" space do not require doors.

## ADVANCED SUPPORT VEHICLE MAXIMUM BAY DOORS TABLE

Unit Type (and Size)	Maximum Bay Doors
Any Support Vehicle (Small)	4
Any Support Vehicle (Medium)	4
Satellite Support Vehicle (Large)	6
Rail Support Vehicle (Large)	8
Airship Support Vehicle (Large)	8
Naval Support Vehicle (Large)	7 + [Unit Weight ÷ 50,000]*

\*Round fractions up

A transporting unit's launch rate (per turn) for onboard fighters or other launch-capable units with appropriate cubicles (Small Craft, 'Mechs and ProtoMechs) is equal to twice the number of functioning bay doors associated with its launch-capable units. For example, a Naval Support Vehicle with 18 fighters in a single fighter transport bay that has 2 doors assigned to it may launch 4 of these 18 fighters per turn (2 doors x 2 fighters per door per turn = 4 fighters per turn). Meanwhile, a cargo train that has 12 BattleMechs across two bays, each of which has 2 doors, would be able to deploy 8 'Mechs per turn (2 doors per bay x 2 bays x 2 BattleMechs per door per turn = 8 BattleMechs per turn).

At 20 tons, Eric's Starcomm Satellite has 7 slots available for items and weapons. With just 9 unspent tons remaining, he decides to spend it all on communications equipment—all of which occupies only 1 slot. Because he specifically chose to make his unit an unmanned satellite, Eric knows that this equipment requires no crew, and thus will function as a kind of relay system. (This means enemy units can potentially make use of the same satellites, of course, but as the Starcomm's primary mission is not military in nature, Eric has no real problem with this.) The communications equipment requires no facing, and its 1 Support Vehicle slot is assigned to the unit's main body.

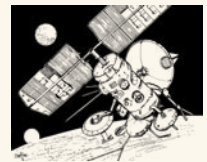

For the 600-ton main tractor of his Adelante Rail unit, Frank decides that the remaining 28 unspent tons would be best employed for cargo purposes, and so assigns a single, standard 28-ton cargo bay to the unit's

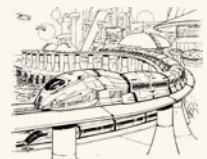



body at a cost of only 1 of the unit's 41 equipment slots. A weight-free (and slot-free) bay door is then added to the Right side for loading and unloading purposes.

For the 120-ton Omni railcars, Frank decides that the remaining 101.5 unspent tons (and all 17 equipment slots) will be sufficient "pod space" for any configuration desired, effectively completing it as a base configuration. As a sample Primary configuration, intended for VIP use, he decides to install 9 first-class passenger quarters for 90 tons (10 tons per quarters x 9 quarters = 90), and 1 second-class quarters for 7 tons, leaving the remaining 4.5 tons for a cargo bay for additional storage, and a weight-free Left-Side bay door. The cargo bay itself takes up 1 item slot, while its bay door is considered free. The single second-class passenger quarters will take up another slot (1 quarters ÷ 20 quarters per slot = 0.05, round up to 1), while the 9 first-class quarters will take up another 2 item slots (9 quarters ÷ 5 quarters per slot = 1.8, round up to 2). The quarters and the cargo bay are given no facing, and are thus assigned to the unit's Body location.

George wants his Cloud Nine Airship to excel as an airborne support unit, capable of transporting and servicing aircraft without having to land. With 699 unspent tons (and 45 item slots) remaining, he decides to invest heavily in support gear for this role. He installs 2 Arresting Hoists at 3 tons (and 1 slot) each, 4 mounted searchlights at 0.5 tons (and 1 slot) each, 1 fully functional Aerospace Fighter bay for 150 tons (and 1 slot), 7 tons of communications equipment (at 1 slot's cost), and a 20-ton (and 1 slot) mobile field base for added maintenance support. He even adds an extra 400 tons' worth of standard cargo space (at 1 slot in equipment space cost) to serve as an extra hangar without the amenities of a fighter bay. This so far costs the Cloud Nine 585 tons ([2 Arresting Hoists x 3 tons] + [4 Searchlights x 0.5 tons] + [1 Fighter Bay x 150 tons] + [7 tons of communications equipment] + [1 Mobile Field Base x 20 tons] + [400 tons of standard cargo] = 585 tons), and 10 item slots. A weight-free/slot-free bay door is assigned to the rear of the craft for launching and recovery purposes (George sees this as an underside door).

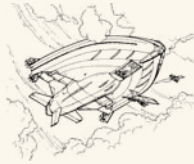

The Cloud Nine already has a crew of 5 plus 1 officer at this time, whose accommodations are provided free with the structural design. The mobile field base and the 7 tons of communications equipment, however, added 12 required crewmen to the design's minimum needs, which also ups its officer requirement to 4, as the Cloud Nine will now have a crew of 17 (5 + 12 = 17) and thus needs 4 officers (17 ÷ 5 crewmen per officer = 3.4 officers, round up to 4). Because these crew are required to meet the Cloud Nine's minimum needs, their accommodations are considered free to the unit's design. However, George notes that being a carrier Airship means the Cloud Nine will have some secondary support personnel for the craft it services as well, such as bay personnel for the fighters and so forth. He thus opts to allow for any extra personnel by installing 15 steerage-class passenger quarters to the Airship at 5 tons per quarters (for a total of 75 tons). These quarters will

require 2 item slots (75 steerage quarters ÷ 50 quarters per slot = 1.5 slots, round up to 2). For the remaining 39 tons of unspent tonnage, George decides to devote all of it to a secondary cargo storage area, with 2 weight-free/slot-free bay doors (1 to the left and 1 to the right side). The cargo bay takes up one additional item slot.

Henry's Jormungand is a seagoing warship that he sees as primarily focused on shoreline fire support and escort for other large ocean-going vessels. With 9,501.5 unspent tons (and 635 item slots) available for weapons and other equipment, he decides to start with weaponry. For primary ship-to-shore firepower, he chooses 6 Long Tom artillery pieces (see p. 284), at 30 tons (and 30 slots) apiece. He plans to set 3 of these weapons each in two of the ship's five turrets, and chooses Turrets 2 and 6 respectively (representing the second and sixth hexes from the vessel's front, respectively). This means that each Long Tom turret will have a turret mechanism weight of 9 tons (90 tons for 3 Long Toms ÷ 10 = 9 tons). For additional long-range firepower, Henry places 2 LRM 20s (at 10 tons and 5 slots apiece) in a third turret (Turret 3, just behind the first Long Tom turret), which will have a turret mechanism weight of 2 tons (20 tons for 2 LRM-20s ÷ 10 = 2 tons), backed up by 2 LR Torpedo-20s (also at 10 tons and 5 slots each) in a fixed mount at the ship's Front. For close-in work, Henry rounds out this firepower with 4 PPCs (7 tons and 3 slots each) and 2 AC/10s (12 tons, 7 slots each) divided evenly among the two remaining turrets (which he places in hexes 1 and 7), and 6 SR Torpedo-6 launchers (3 tons, 2 slots each); 2 of each are placed in fixed mounts on the Fore-Left side (in hex 3, for range references), Fore-Right side (also in hex 3) and the Rear. The PPCs and autocannon will give both of the turrets in which they are mounted a mechanism weight of 3 tons ([14 tons for 2 PPCs + 12 tons for AC/10] ÷ 10 = 2.6, round up to 3).



For the ammo-based weapons, Henry provides 60 tons (60 x 5 shots per ton = 300 shots) for the Long Toms, 24 tons to the AC/10s (24 x 10 shots per ton = 240 shots), 40 tons to the LRM-20s (40 x 6 shots per ton = 240 shots), 40 tons to the LRT-20s (40 x 6 shots per ton = 240 shots) and 24 tons to the SRT-6s (24 x 15 shots per ton = 360 shots). On a smaller, single-hex Support Vehicle, each of these ammo types would occupy only 1 slot in the vehicle's design, assigned automatically to the body location. But because the Jormungand is a multi-hex unit, Henry must spread the ammunition bins out among the various hexes where each weapon is mounted. Thus, he places two slots of Long Tom ammo (each slot carries 30 tons of ammunition) in the ship's second and sixth Body hexes (where the Long Tom turrets are located). Likewise, he assigns all LRM ammo to the second Body hex (where the LRM-20 turret is), and divides the AC/10 ammunition into two slots assigned to the first and seventh Body hexes (providing 6 tons of ammo to each AC/10 turret). The 40 tons of LRT-20 ammunition occupy a single slot in

INTRODUCTION

ADVANCED  
GROUND MOVEMENT

ADVANCED  
COMBAT

ADVANCED  
BUILDINGS

ADVANCED  
SUPPORT  
VEHICLES

GENERAL  
RULES

ADVANCED  
SUPPORT VEHICLE  
CONSTRUCTION

ADVANCED  
WEAPONS  
AND EQUIPMENT

INDEX

RECORD SHEETS



the vessel's first Body hex. With six out of the Jormungand's eight SR-Torpedo launchers located in the ship's third Body hex, Henry places two-thirds of the SRT-6 ammo (16 tons) in an ammo slot in that hex, while the remaining 8 tons of SRT ammo occupies a single slot in the ninth Body hex—the vessel's aftmost location. All told, the ammunition for the Jormungand will occupy 8 slots.

To protect against explosions, Henry also installs CASE, but since his vessel is a multi-hex unit, it must install CASE in every hex, at 0.5 tons (and 1 slot) per hex, for a total of 4.5 tons and 9 slots on the 9-hex-long vessel. Rounding out the firepower, Henry installs Advanced Fire Control as well. With a total weapon weight (discounting turrets, ammunition, and CASE) of 290 tons (180 [6 Long Toms] + 20 [2 LRM-20s] + 20 [2 LRT-20s] + 28 [4 PPCs] + 24 [2 AC/10s] + 18 tons [6 SRT-6s] = 290 tons), the Advanced Fire Control will take up another 29 tons of the Jormungand's weight (290 ÷ 10 = 29 tons), but occupies no equipment slots. With weapons, turret mechanisms, ammo, CASE and fire control, the vessel has now spent 537.5 tons (290 [weapons] + 26 [turrets] 188 [ammo] + 4.5 [CASE] + 29 [Fire Control] = 537.5), and 165 slots (148 [weapons] + 0 [turrets] + 8 [ammo] + 9 [CASE] + 0 [Fire Control] = 165).

Moving on, Henry decides to give his cruiser some air support capacity with a 500-ton (and 5-slot) helipad (which he places in hex 5) and two Light Vehicle Bays at 50 tons (and 1 slot)—each with its own 0-ton/0-slot bay door (facing the fore-left and fore-right arcs, respectively). He also adds 12 tons of communications equipment (which claim 1 slot), a MASH unit with 7 added operating theaters for 10.5 tons (3.5 tons [base] + [7 added theaters x 1 ton each] = 10.5 tons) and 1 slot, and 2 field kitchens at 3 tons (and 1 slot) apiece. He then adds 4 mounted searchlights at 0.5 tons and 1 slot each (1 each mounted to the Fore, Fore-Left, Fore-Right and Rear sides), and 30 lifeboats at 1 ton (and 0 slots) each. This added equipment combines for an additional 660.5 tons and 15 slots spent.

Satisfied with the equipment, Henry reviews his Jormungand's crew needs. At 60,000 tons, the vessel has a base minimum crew of 15 (3 + [60,000 tons ÷ 5,000] = 15), and thus a minimum officer requirement of 3 (15 crew ÷ 5 = 3 officers)—which Henry accounted for earlier. In addition, much of its non-weapon equipment adds 63 to the crew minimums (5 [helipad] + 12 [12-ton communications equipment] + 40 [MASH with 8 operating theaters] + 6 [2 field kitchens] = 63), while the vessel's 290 tons of weaponry adds a minimum requirement of 97 gunners (290 weapon tons ÷ 3 = 96.67, round up to 97). Added to the 15 base crew needs, the Jormungand requires a total minimum of 175 crew (15 [base] + 63 [non-gunners] + 97 [gunners] = 175), and a corresponding minimum of 35 officers (175 crew ÷ 5 = 35 officers). Henry decides to exceed these minimums, however, to provide a little extra coverage in the event of casualties at sea and the like. He decides on a final count of 266 enlisted/non-rated crew, plus 102 gunners, and 77 officers to command them—exceeding the vessel's minimum needs by 193 crewmen (266 non-gunners + 102 gunners – 175 minimum crew = 193) and 42 officers (77 officers – 35 minimum officers = 42). In addition, Henry decides he wants to have at least four conventional platoons' worth

of marines on his vessel (84 troopers in all). The minimum crew's quarters are provided free with the vessel's chassis, and so Henry doesn't need to assign weight or slots to them, but extra crew, officers and marines all will require quarters. Feeling generous, Henry decides to also provide quarters for the 10 bay personnel that come with the two Light Vehicle Bays he has installed. Using standard 7-ton crew quarters for the 287 extra crew, bay personnel and marines (193 extra crew + 10 bay personnel + 84 marines = 287), he spends a total of 2,009 tons here, at a slot cost of 15 (287 extra crew quarters ÷ 20 quarters per slot = 14.35, round up to 15). The extra officers, whose quarters weigh 10 tons each, add another 420 tons (and 9 slots; 42 officers quarters ÷ 5 = 8.4, round up to 9) to this tally—for a total of 2,429 tons and 24 slots in quarters.

Having now spent a total of 3,627 tons (537.5 [weapons] + 660.5 [non-weapons] + 2,429 [quarters] = 3,627) and 201 slots (162 [weapons] + 15 [non-weapons] + 24 [quarters] = 201), Henry finds he still has 5,874.5 tons (9,501.5 – 3,627 = 5,874.5 tons) and 434 slots (635 – 201 = 434) left to spend. He decides to assign 4,000 tons (and 1 slot) to a standard cargo bay (assigned to the hull, with a bay door assigned to the Aft-Right arc), and the remaining 1,874.5 tons (and 1 slot) to a special refrigerated cargo bay (also assigned to the hull, but with its bay door facing the Aft-Left arc). For the sake of completeness, Henry computes the capacity of this refrigerated bay to be 1,630 tons (1,874.5 tons actual size ÷ 1.15 = 1,630).

---

## STEP 6: COMPLETE THE RECORD SHEET

---

By the time the designer has chosen all structure, engine and controls for the advanced Support Vehicle, and added armor, weapons and equipment, all items must be allocated to their proper places on the appropriate Blank Record Sheet. For a completed Record Sheet, the designer must make sure to have selected the appropriate sheet for the unit's type. The sheet must have all data filled in for the Vehicle Data block (including name, tonnage, engine and movement types, and MP/Thrust). All equipment slots must be allocated on the Weapons and Equipment Inventory (including ammunition and number of shots per bin). All extraneous armor and internal structure points must be blacked out on the Armor Diagram.

Once all of the above is completed, the advanced unit is ready for game play.

### SUPPORT OMNIVEHICLES

When completing the Record Sheet for an advanced Support Vehicle built as an OmniVehicle, it is highly recommended that the designer create one sheet specifically for the base configuration, with none of the weapons or equipment installed that may appear on the Primary and Alternate configurations. Copies of this Base Configuration Record Sheet (noting all unused tonnage as pod space for the body and the turret separately) can then be used to quickly generate record sheets for the other configurations.



# DESIGNING MOBILE STRUCTURES

The following basic rules cover the construction of Mobile Structures, particularly large units capable of travel over land, sea and air, but whose designs are often unique and more akin to buildings than their vehicular analogs. Despite their range of types, these advanced units follow five simple steps in design, each of which is described in detail later. In brief, these steps are as follows.

**Step 1:** Establish Function—Determine the Mobile Structure's class, technology base, structure type, size, Construction Factor (CF).

**Step 2:** Install Power, Motive and Control Systems—Determine the Mobile Structure's speed, power and motive systems, and determine crew needs.

**Step 3:** Install Armor—Determine type, amount and weight of armor (if any), and add armor points.

**Step 4:** Install Weapons, Heat Sinks and Equipment—Add weapons, any required heat sinks and other equipment to the advanced unit.

**Step 5:** Complete the Record Sheet.

The above steps are a framework for designing a Mobile Structure. The actual process—particularly after the function and motive systems are determined—can involve a bit more flexibility as equipment and armor are balanced for their best fit in terms of tonnage and weapon slots. For example, some designers might wish to assign armor after the weapons and heat sinks are established, to maximize firepower over protection. Others may want to add equipment first, leaving any remaining tonnage to armor.

To assist in this effort, the designer may find it useful to make copies of an appropriate Blank Record Sheet (in the back of this book), to visually arrange the placement of weapons and equipment while tracking the use of weight on a piece of scratch paper. Alternatively, designers with access to a PC and the appropriate *Heavy Metal* software can use it to develop their advanced unit electronically.

**Terminology:** Mobile Structures are unique among other battlefield units in that they are not constructed so much by a weight standard, though their design uses weight as a regulating factor. Rather than using weight classes, Mobile Structures identify their "class" by their Construction Factor (CF), which may be Light, Medium, Heavy or Hardened. Mobile Structures also come in three main structure types: Hangar, Building and Fortress. The combination of a Mobile Structure's class and type heavily influence its upper size limits (both in hexes and level of height), and its internal weight capacity. Because Mobile Structures are always multi-hex units, the size (in hexes) of a Mobile Structure influences where items may be mounted. Meanwhile, weight (tonnage) becomes a factor when discussing a Mobile Structure's internal weight capacity (the amount of tonnage a given hex may support within its framework), dictating how much equipment may be mounted inside.

# STEP 1: ESTABLISH FUNCTION

The first step in creating a Mobile Structure is choosing the unit's primary function and mode of travel. This step determines some of the most basic aspects of its design, including what type of unit it is, its technology base and its structural strength. These choices will restrict the designer's access to certain equipment and can also influence the unit's capabilities in game play.

## CHOOSE MOBILE STRUCTURE TYPE

Mobile Structures come in three main structure types that can affect their motive systems, size, maximum Construction Factor and engine options. Because of this, choosing the unit's type is the first key part of the structure's design process.

The Mobile Structure Types Table below provides key data that applies to Mobile Structure design and game play. Each of the structural types covered by these rules is listed in the Mobile Structure Type column, along with its Class (Light, Medium, Heavy or Hardened), Maximum Size (in hexes and levels of height), Construction Factor range (based on class), Motive System types and special notes regarding the nature of its construction (such as whether or not the structure may be armed with heavy weapons, or mount additional armor).

The Mobile Structure types are broadly described by their standard structural equivalents (Building, Hangar and Fortress), which are described more fully below.

**Buildings:** Building-type structures represent everyday structures such as barracks and on-site housing, administrative centers, infirmaries and such. These structures fall into the Light, Medium and Heavy CF categories.

Buildings may not be armored, nor may they mount heavy weapons (weapons individually weighing more than 0.25 tons). However, these structures may house non-weapon equipment useful for their function—such as crew quarters for barracks and housing, communications equipment for administrative centers, MASH and paramedic gear for infirmaries, and so forth.

Building-type Mobile Structures may be built as ground-based units, flying units or seafaring units (floating and submersible).

**Hangars:** Hangar-type structures are specialized constructs built with large empty spaces. Typically intended to house vehicles, 'Mechs, fighters and other bulk cargo, these structures come in Light, Medium, Heavy or Hardened CFs and may not be armored. As a consequence of their open internal construction, however, Hangars support only half the CF value of their equivalent Building type. Hangars must stand at least as tall as the units they house (2 levels for 'Mech units, 1 for most others), and should have a Large Door on at least one facing (considered free for purposes of equipment tonnage).

Like Buildings, Hangars may not mount armor or heavy weapons. Their open design enables them to mount more equipment than comparable Buildings and in a similar fashion, but the weight of any such gear mounted in a Hangar tops out at 300 tons per hex for every 4 levels of structure height (or fraction thereof), even if the structure's CF would otherwise support more.

Hangar-type Mobile Structures may be built as ground-based units, flying units or seafaring units (floating and submersible).

INTRODUCTION

ADVANCED  
GROUND MOVEMENT

ADVANCED  
COMBAT

ADVANCED  
BUILDINGS

ADVANCED  
SUPPORT  
VEHICLES

GENERAL  
RULES

ADVANCED  
SUPPORT VEHICLE  
CONSTRUCTION

ADVANCED  
WEAPONS  
AND EQUIPMENT

INDEX

RECORD SHEETS



## MOBILE STRUCTURE TYPES TABLE

Mobile Structure Type (Class)	Max Size (Hexes/Levels)*	Construction Factor (CF)	Motive Systems	Notes
Buildings	—	—	Ground, Air, Naval	May not be armed or armored
Light	6/5	1-15		
Medium	8/8	16-40		
Heavy	10/10	41-90		
Hangars	—	—	Ground, Air, Naval	May not be armed or armored;
Light	10/7	1-8		Max 300 tons of equipment per hex (per 4 levels)**
Medium	14/10	9-20		
Heavy	18/13	21-45		
Hardened	20/14	46-75		
Fortress	—	—	Ground, Naval	May be armed/armored at extra cost
Medium	12/15	16-40		
Heavy	15/20	41-90		
Hardened	20/30	91-150		

\*Naval units stand only half their height (rounded down) when operating on the surface while the remaining levels extend below the surface of the water (submersibles are never fully submerged unless they descend low enough to place their uppermost levels below the surface); Ground units receive an additional 2 levels of height from their motive systems for line of sight purposes, but do not count this height toward the Maximum height in levels and do not add these levels into any calculations based on height.

\*\*Round up

**Fortresses:** Fortress-type structures are available in Medium, Heavy or Hardened CFs. Unlike Hangars and Buildings, they may be armored or even mount heavy weapons. The mass of armor and weapons a Fortress may mount per hex varies with the structure's CF, but is considered additional to any non-combat gear, which may be placed within such structures as noted above under *Buildings*. An armored Fortress must distribute its armor to each hex of the structure.

Fortress-type Mobile Structures may be built as ground-based or water-based units (floating and submersible), but may not be constructed as flying craft.

*Nicholai is interested in building a super-sized trans-oceanic vessel capable of hauling massive amounts of bulk cargo to far-flung coastal cities on Fomalhaut. As he doesn't plan this to be a military vessel and intends for it to serve as a cavernous cargo hauler, he decides to construct it with the light and open framework of a Hangar, and so uses a Hangar-type Mobile Structure design.*



*Paul is interested in building a skybase—an unusual floating city and headquarters platform. Though this skybase may have military applications, Paul notes that he cannot make it as a Fortress-type Mobile Structure (because Fortress-type structures cannot have an Air motive system), and so it cannot be armored or armed with heavy weapons. To maximize his structure's resiliency, he opts for a Building-type Mobile Structure, which offers greater CF capacity.*



*Raymond wants to build a DropShip-mover platform, used to move grounded spheroid DropShips around in crowded spaceports. Even though he does not truly expect such ship movers to come under fire, he nevertheless selects a Fortress-type Mobile Structure for the job, anticipating a need for the maximum possible CF to support his structure's expected cargo capacity.*



### CHOOSE TECHNOLOGY BASE

Mobile Structures may be constructed using Clan or Inner Sphere technology bases. Mobile Structures may not be constructed as Omnis. However, they may be constructed as special "Modular Structures" that can link up with other Mobile Structures of similar motive type and movement rates.

*Nicholai establishes an Inner Sphere tech base for his super cargo vessel. Because he plans to maximize its cargo capacity, he conceives of the vessel as a series of structure modules.*



*Paul decides that his skybase will have an Inner Sphere tech base.*



*Raymond chooses an Inner Sphere tech base for his DropShip-mover.*





## CHOOSE CLASS, SIZE, AND SHAPE

Depending on the Mobile Structure's class, its maximum (and minimum) size and Construction Factor values can vary greatly (as shown on the Mobile Structure Types Table). In this respect, a Mobile Structure's class is equivalent to a combat unit's weight class, and Mobile Structures may be identified—as their structure type permits—as Light, Medium, Heavy or Hardened.

Once a class is decided upon, the designer may set the size and shape of the Mobile Structure (in 30-meter hexes, by 6-meter levels). This shape is recorded by using the layered hexagonal map on the right-hand side of the Mobile Structure's Record Sheet and blacking out all extraneous hexes. For simplicity's sake, a Mobile Structure's shape must be a continuous grouping of hexes no greater than the hexside of the structure class (as defined by the number left of the slash in the Max Size column). These hexes need not be all of the same height, but the highest level chosen for all hexes may not exceed that of the number right of the slash in the Max Size column for the unit's class, and is used as the general height for the Mobile Structure itself for purposes of costs and structural weight capacity.

**Minimum Size:** Mobile Structures are multi-hex units by definition. Thus, the minimum size for any Mobile Structure is 2 hexes.

*Nicholai chooses a Hardened class for his super-freighter, to achieve the maximum size for each structure module. He decides to use all 20 hexes worth of Hangar size for his vessel, which he arranges in a chevron-shaped area 4 hexes long and 5 hexes wide. He also decides the Mobile Structure will stand at its maximum height of 14 levels. (As a surface-going naval-type Mobile Structure, this means that the freighter will float with 7 levels above the water surface, and 7 below.)*



*Paul decides on a Heavy class Building for his skybase. This gives him a maximum Mobile Structure size of 10 hexes in area by 10 levels in height. He takes the maximum hex size and arranges the structure in a wedge shape, 1 hex wide at the tip and 4 hexes wide at the base, with a height of 5 levels.*



*Raymond decides to make his DropShip-mover a Hardened class, but does not opt for the maximum Fortress-class structure size of 20 hexes by 30 levels. Instead, he sees his unit as a 19-hex structure, arranged on his Record Sheet in a hexagonal "circle" 3 hexes on a side (and 5 hexes at the widest points), with a height of 4 levels. Because it will be ground mobile, this will make the structure's actual height 6 levels tall, but the lower 2 levels will not count for any height-based computations.*



## CONSTRUCTION FACTOR AND INTERNAL WEIGHT CAPACITY

The class of the Mobile Structure also helps select its Construction Factor (CF), which determines its damage capacity per hex (regardless of height), as well as its internal weight capacity. The CF is recorded on the Record Sheet in the CF block.

For each hex of Mobile Structure area covered, Building- and Fortress-type structures may internally carry a total tonnage of equipment (including weapons, heat sinks and armor) equal to their Construction Factor times the number of levels of structure height. Because of their open frames, Hangar-type structures may triple this capacity, but that same open frame means they can only support a maximum of 300 tons of equipment per hex for every 4 levels of structural height (or fraction thereof), even if their structural tonnage capacity would support more.

*As a Hardened-class Hangar-type structure has a maximum possible CF of 75, Nicholai decides to give his Hangar-type Mobile Structure a CF of 75. This means that each hex of the structure will be able to support 1,200 tons of weight (300 tons x [14 levels high ÷ 4 = 3.5, round up to 4] = 300 x 4 = 1,200 tons).*



*After assigning a CF of 90—the maximum possible CF under the Heavy-class Building type—to his structure, Paul finds that each hex will support 450 tons of equipment (5 levels x 90 CF = 450 tons).*



*Raymond decides to give his DropShip-mover (a Hardened-class structure with a maximum CF of 150) its maximum CF, to better bear the strain of its intended load. He finds that such a Mobile Structure would be able to support 600 tons of equipment weight per hex (4 levels [not counting the bonus 2 for being ground-mobile] x 150 CF = 600 tons).*

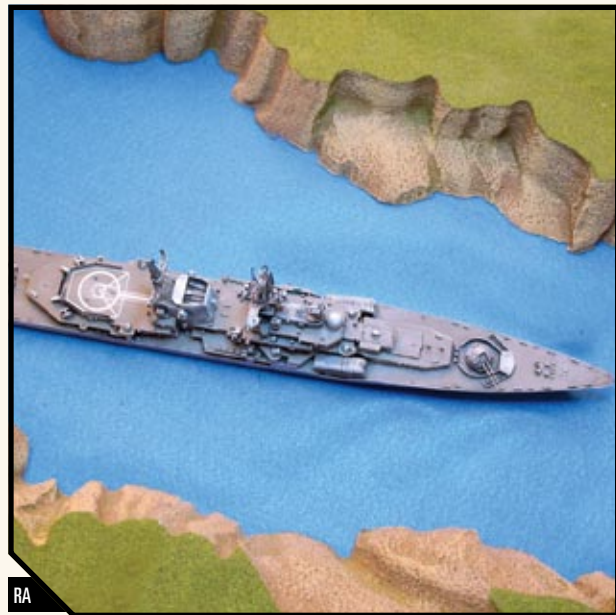

*A relic plies the Thames river to fight Blakist forces on New Avalon.*

INTRODUCTION

ADVANCED  
GROUND MOVEMENT

ADVANCED  
COMBAT

ADVANCED  
BUILDINGS

ADVANCED  
SUPPORT  
VEHICLES

GENERAL  
RULES

ADVANCED  
SUPPORT VEHICLE  
CONSTRUCTION

ADVANCED  
WEAPONS  
AND EQUIPMENT

INDEX

RECORD SHEETS



## STEP 2: INSTALL POWER, MOTIVE, AND CONTROL SYSTEMS

The second step in Mobile Structure design is the installation of the unit's power and motive systems. This step establishes key factors in the unit's mobility, including the size and performance of its engine and its crew needs for operations.

### INSTALL POWER SYSTEM

Thanks to their sheer size, the power systems for a Mobile Structure are more generalized and distributed than on other unit types. The power system runs the unit's drive systems as well as any other onboard components, such as weapons and heavy equipment.

The power systems available to Mobile Structures can vary somewhat, with a range of possible "engines" similar to those found on Support Vehicles (Steam, Internal Combustion, Fuel Cell, Fission and Fusion are all available to Mobile Structures). The weight of these power systems is based on the size of the Mobile Structure, its technology base and motive type, and the desired maximum speed (in Movement Points).

Mobile Structures do not have a Cruising and Flanking rating; just a maximum MP. Mobile Structure Movement Points may be purchased in quarter-points, rather than whole MPs, and depending on the motive type used, all such units receive a set maximum. (See the game play rules for Mobile Structures, p. 165, for information on how these units spend their Movement Points.)

To find the total weight of a Mobile Structure's power system, multiply together the structure's size (in hexes), its height (in levels), its desired movement rate (in MPs) and its Power System Weight Multiplier (shown in the Mobile Structure Power and Motive Systems Table below). Round all weights up to the nearest full ton.

## MOBILE STRUCTURE POWER AND MOTIVE SYSTEMS TABLES

### MOBILE STRUCTURE POWER SYSTEM, MOTIVE SYSTEM, AND FUEL WEIGHT FORMULAE

Power System Weight = Structure Size (Hexes x Levels) x MP x Power System Weight Multiplier

Motive System Weight = Structure Size (Hexes x Levels) x Motive Type Multiplier x Structure Type Multiplier\*

Fuel Weight = Desired Range (in hundreds of kilometers) x Fuel Multiplier x Power System Weight

\*Structure Type Multiplier = 0.3 for Hangars, 0.5 for Buildings, and 1.0 for Fortresses

### MOBILE STRUCTURE POWER SYSTEM WEIGHT MULTIPLIERS

Mobile Structure Power System Type	Power System Weight Multiplier (by Tech Base and Motive Type)						Fuel Multiplier: (% of Power System Wt. Per 100 km)
	Inner Sphere			Clan			
	Ground	Air	Naval*	Ground	Air	Naval*	
Steam	6.0	6.0	6.0 / 7.0	7.0	7.0	7.0 / 8.0	4.0
Internal Combustion (ICE)	3.0	3.0	3.0 / 3.2	3.0	3.0	3.0 / 3.0	2.0
Fuel Cell	4.0	4.4	4.0 / 5.0	4.0	4.2	4.0 / 4.4	2.0
Fission	3.0	3.0	3.0 / 3.0	4.0	4.0	4.0 / 4.0	NA
Fusion	2.0	2.0	2.0 / 2.2	1.8	1.8	1.8 / 2.0	NA

\*Left of Slash = Surface-only movement; Right of slash = Submersible

### MOBILE STRUCTURE MOTIVE SYSTEM WEIGHT MULTIPLIERS

Mobile Structure Motive Type	Max MP (Type)*	Motive Type Multiplier (by Tech Base)	
		Inner Sphere	Clan
Ground	2 (Tracked)**	4.0	3.5
Air	4 (VTOL)	5.0	4.0
Water (Surface-only)	3 (Naval)	2.0	1.8
Water (Submersible)	4 (Naval, Submarine)	3.5	3.5

\*MPs for Mobile Structures may be purchased in quarter-points; Mobile Structures have no Flank MP rating, nor may they Jump

\*\*Ground-based Mobile Structures increase the Structure's Height by 2 for LOS purposes, but do not affect height-based construction calculations or tonnage capacity; no equipment may be mounted on the lowest 2 Levels



## INSTALL MOTIVE SYSTEM

In addition to their power systems, Mobile Structures also must devote tonnage toward the motive systems that enable the unit to move.

As with power systems, Mobile Structures have multiple options in motive system design. Ground-based Mobile Structures use tracks and/or wheels to negotiate terrain. Airborne Mobile Structures use a combination of rotors and lighter-than-air cells that provide sustainable lift (if not high-speed flight). Naval Mobile Structures allow for seafaring units, which can be made as either super-sized surface vessels or—if properly sealed—submersibles.

The amount of tonnage these motive systems require from the Mobile Structure's overall internal weight capacity depends on the unit's size, its exact motive type (ground-based, airborne, surface naval or submersible), its technology base (Clan or Inner Sphere), and its basic structure type (hangar, building, or fortress). To find the total weight of a Mobile Structure's power system, multiply together the structure's size (in hexes), its height (in levels), its Motive Type Multiplier (shown in the Mobile Structure Power and Motive Systems Table below), and its Structure Type Modifier. Round all weights up to the nearest full ton.

**Distributed System Weights:** Once the total weight of the power and motive systems is known, the tonnage used is dispersed among the Mobile Structure's hexes, effectively limiting the weight capacity of each hex as power conduits and drive systems are spread evenly throughout the design. To find this per-hex weight, divide the total power and motive system weights by the number of hexes the unit occupies, and round up to the nearest half-ton.

**Modular Structures:** Mobile Structures built as Modular Structures still require power and motive systems, which must be of the same MP and type as the other Modular Structures with which they are intended to unite.

**Tech Base:** Under these rules, Clan-made power and motive systems may not be employed on Inner Sphere-made Mobile Structures. Likewise, Clan-made Mobile Structures may not employ power or motive systems with an Inner Sphere technology base.

*Nicholai's super-sized Mobile Structure occupies 20 hexes and has a height of 14 levels. He intends it to operate as a surface naval vessel, and chooses an internal combustion engine for its power system, with a desired top speed of 1.25 MP. Based on these choices, he finds that the power systems for this Mobile Structure will weigh 1,050 tons (20 hexes x 14 levels x 1.25 MP x 3.0 Inner Sphere surface naval power system = 1,050). The motive systems, meanwhile, will weigh an additional 168 tons (20 hexes x 14 levels x 2.0 Inner Sphere surface naval motive system x 0.3 for a Hangar-type structure = 168).*

*Distributing these systems, Nicholai finds that each hex of his Mobile Structure will house 52.5 tons of power systems (1,050 tons ÷ 20 hexes = 52.5 tons per hex) and 8.5 tons of motive system equipment (168 tons ÷ 20 hexes = 8.2 tons per hex, round up to 8.5). Subtracted from the 1,200-ton weight capacity per hex, these systems will leave the unit with 1,139 tons of internal capacity per hex (1,200*



*tons per hex – [52.5 power system tons + 8.5 motive system tons] = 1,139 tons).*

*With its 10-hex size, 5 levels of height and CF of 90, Paul has given his airbase an airborne (VTOL) motive system with 4 MP of movement, and chooses a Fusion power system to keep it aloft. He computes the power system will run 400 tons in total (10 hexes x 5 levels x 4 MPs x 2.0 Inner Sphere airborne power system multiplier = 400 tons). The motive system will weigh an additional 125 tons (10 hexes x 5 levels x 5.0 Inner Sphere motive system multiplier x 0.5 for Building-type structure = 125 tons).*



*Dividing both figures by the airbase's 10-hex size, he finds that each hex will devote 40 tons to power systems and 12.5 to motive systems. Subtracted from the 450-ton weight capacity per hex, these systems will leave the unit with 397.5 tons of internal capacity per hex (450 tons per hex – [40 power system tons + 12.5 motive system tons] = 397.5 tons).*

*Raymond decides to give his ground-based DropShip-mover (a 19-hex, 4-level high Mobile Structure) a Fusion power system and a maximum MP of 2.*



*He finds that the power system for this unit will weigh 304 tons (19 hexes x 4 levels x 2 MP x 2.0 Inner Sphere Fusion power system multiplier = 304 tons), and the motive system will also weigh 304 tons (19 hexes x 4 levels x 4.0 Inner Sphere Ground motive system multiplier = 304 tons).*

*Dividing these values by 19 hexes, he finds that the power and motive systems will each take up 16 tons per hex (304 tons ÷ 19 hexes = 16 tons per hex). Subtracted from the 600-ton weight capacity per hex, these systems will leave the unit with 568 tons of internal capacity per hex (600 tons per hex – [16 power system tons + 16 motive system tons] = 568 tons).*

## DETERMINE FUEL CAPACITY

Mobile Structures have significant fuel requirements, and burn fuel in a similar fashion to Support Vehicles. Like many Support Vehicles, this fuel capacity is expressed as an operating range for the unit, which is computed based on the engine type and the desired operating range (in hundreds of kilometers). Though some Mobile Structure engines may lack fuel requirements (notably Fission- and Fusion-powered types), all others that require fuel must allocate some weight—in addition to their power and motive systems—to internal fuel supplies.

To find the fuel weight for a Mobile Structure, multiply the desired range (in hundreds of kilometers) by the listed percentage of the unit's power system weight shown in the Mobile Structure Power System Multipliers Table. (An entry of NA means that Mobile Structures using those power systems need not purchase fuel reserves.) This figure is rounded up to the nearest ton. For example, a Mobile Structure unit with a 520-ton fuel cell power system and a desired operating range of 1,000 kilometers would add 104 tons of fuel to its design (520 tons [power system weight] x 0.02 [2.0 percent per 100 km for fuel cells] x 10 [hundreds of kilometers desired; 1,000 ÷ 100 = 10] = 104 tons).

INTRODUCTION

ADVANCED  
GROUND MOVEMENT

ADVANCED  
COMBAT

ADVANCED  
BUILDINGS

ADVANCED  
SUPPORT  
VEHICLES

GENERAL  
RULES

ADVANCED  
SUPPORT VEHICLE  
CONSTRUCTION

ADVANCED  
WEAPONS  
AND EQUIPMENT

INDEX

RECORD SHEETS



**Distributing Fuel Tanks:** Unlike power and motive systems, which must be distributed evenly throughout a Mobile Structure's design, fuel storage may be distributed as desired. Mobile Structure units may place as much as 100 percent of their fuel storage (if possible) in a single hex of the unit's design, or divide the supply (as evenly as possible) among multiple structure hexes. The locations of any fuel storage (and quantities thereof in weight) must be noted on the unit's record sheet.

**Modular Structures:** Mobile Structures built as Modular Structures retain their separate power and motive systems, and thus also retain separated fuel supply systems. The fuel supply of a single module may not be shared with other modules in the linked unit, and so all Mobile Structure modules must invest weight in their own fuel supplies. The operating range of a linked Mobile Structure will be that of its shortest-ranged module.

**Tech Base:** Fuel tanks and fuels are standardized, and equally available to Mobile Structures of Clan or Inner Sphere technology bases.

For its 1,050-ton Internal Combustion power system, Nicholai decides to give his Mobile Structure an operating range of 7,000 kilometers. He finds that this will cost the unit a total of 1,470 tons (1,050 tons [power system weight] x 0.02 [2.0 percent per 100 km for internal combustion] x 70 [hundreds of kilometers desired; 7,000 ÷ 100 = 70] = 1,470). Because this figure exceeds the 1,139-ton internal capacity of a single hex worth of this Mobile Structure, Nicholai decides to divide his fuel tanks up among two of his vessel's centrally-located hexes, with 735 tons applied to each. Those hexes will therefore have an internal weight capacity of 404 tons (1,139 - 735 = 404).



For its 400-ton Fusion power system, Paul finds that no fuel supply is required. His airbase has an effectively unlimited range.



Raymond's DropShip-mover also uses a Fusion power system, and so also requires no fuel storage.



## ADD CREW

The control systems that regulate mobility and power on a Mobile Structure are integral to the power and motive systems already established above. However, as these systems still require a crew to operate them, Mobile Structures must allocate additional mass to crew accommodations as needed.

**Crew:** All Mobile Structures require a certain amount of crew to operate them. To determine the basic crew needs for a Mobile Structure, consult the Mobile Structure Minimum Crew Table below, taking into account the Mobile Structure's size (in hexes) and motive type. A Mobile Structure's crew must be equal to (or, at the designer's option, greater than) the sum of its minimum crew requirements (including any supplemental crew such as officers and those needed to man special equipment such as weapons, communications, kitchens and MASH theaters). Bay personnel—for vehicle bays and such—are not listed (the bays themselves incorporate a limited amount of bunk space for such personnel). Additional crew needs for the specific items listed do not have to be met unless and until the items are mounted (typically after Step 4), and any officer requirements must be computed after all crew is assigned.

## MOBILE STRUCTURE MINIMUM CREW TABLES

### Minimum Crew Formula:

Minimum Crew Needs = (Base Crew Minimum x Structure Size [in hexes]) + Minimum Gunners + Minimum Officers

### Base Crew Minimum (per Hex, by Motive Type)

Mobile Structure Class	Ground-Based	Airborne	Naval (Surface)	Naval (Submersible)
Hangar	2	3	2	3
Building	3	4	3	4
Fortress	4	NA	5	6

\*Round fractions down; apply rounding before applying the Base Crew Minimum to the Minimum Crew Formula

### ADDITIONAL CREW

Non-Gunners	Minimum Crew Requirement
Communications Equipment (per ton, see p. 212, TM)	1
Field Kitchen (per item, see p. 217, TM)	3
Flight Deck (per item, see p. 312)	20
Landing Deck (per hex, see p. 319)	3
Helipad (per item, see p. 312)	5
MASH (per theater, see p. 228, TM)	5
Mobile Field Base (per item, see p. 330)	5
Modular Structure Linkage (per item, see p. 265)	4

Gunners	Minimum Gunners*
Per Light Weapon (see p. 266)	1
Per Medium Weapon (see p. 266)	1
Per Heavy Weapon (see p. 266)	Weapon Tons ÷ 5 (round up)
Per Capital Weapon (see p. 276)	7

\*Advanced fire control systems are automatically provided for armed Mobile Structures at no cost; gunners are required only for items that require a Gunnery Skill roll to use in combat.

Officers	Minimum Officer Requirement*
9 Non-Officer Crewmen or less	1
10 or more Non-Officer Crewmen	Total Non-Officer Crew ÷ 10 (round up)

Crew Space: Mobile Structures may distribute their crew quarters evenly among the unit's hexes, or concentrate them to a smaller number of hexes.



Gunners are necessary only for items that require a Gunnery Skill roll to use in combat, and that have a range of more than 1 hex. (Automatic defensive armaments like Anti-Missile Systems, A-Pods and such require no gunners, nor do non-weapon items listed on the Weapons and Equipment Tables, such as Active Probes and ECM gear.)

**Crew Accommodations:** Mobile Structures, often designed to spend days or weeks in the field, provide quarters—rather than mere crewman seating—as part of their design. These crew quarters are very basic, however, and make no allowances for luxuries or passengers beyond the minimum crew needs. Such additional facilities may be added later on.

**Fire Control Systems:** Mobile Structures that are armed automatically incorporate advanced fire control systems into their designs. The massive support of the structure itself makes the weight and cost of any fire control systems negligible.

**Tech Base:** The control systems and crew accommodations covered by these rules are equally available to Mobile Structures built using a Clan or Inner Sphere technology base.

**Crew Space:** Mobile Structures may distribute their crew quarters evenly among the unit's hexes, or concentrate them to a smaller number of hexes.

*For his 20-hex Hangar-class Mobile Structure (which uses a surface naval motive system), Nicholai finds that he has a minimum crew requirement of 44 ([2 Base Crew Minimum for Surface Naval Hangar x 20 hexes = 40] + 0 gunners [at the moment] + 4 officers [40 crew ÷ 10 = 4 officers] = 44).*



*For his 10-hex Building-class airborne Mobile Structure, Paul finds that the minimum crew needs are also 44 ([4 Base Crew Minimum for Airborne Building x 10 hexes = 40] + 0 gunners [at the moment] + 4 officers [40 crew ÷ 10 = 4 officers] = 44).*



*Raymond's DropShip-mover is a 19-hex Fortress-class Mobile Structure with a ground-based motive system, and so currently has a minimum crew need of 84 ([4 Base Crew Minimum for Ground-based Fortress x 19 hexes = 76] + 0 gunners [at present] + 8 officers [76 crew ÷ 10 = 7.6 officers, round up to 8] = 84).*



### SPECIAL ENHANCEMENTS (ENVIRONMENTAL SEALING, MODULAR STRUCTURE LINKAGE)

Two basic enhancements are available to Mobile Structures of all types and classes: environmental sealing and the linkage systems for modular structure. A Mobile Structure may install either (or both) systems as desired.

**Environmental Sealing:** The environmental sealing modification reinforces the outer framework of a Mobile Structure and provides secondary hatches throughout to seal off breaches against hazardous environments (including vacuum, toxic atmospheres and water). It is incorporated automatically with the submersible motive system and so need not be added to such units, but may be added to non-submersible Mobile Structures at this stage.

## MOBILE STRUCTURE SPECIAL ENHANCEMENTS TABLE

Enhancement	Weight (per Hex)*	Required Location
Environmental Sealing	(CF x 0.1) x Height (in levels)	Each Hex
Mobile Structure Linkage	CF x 0.5	Single Hex (Outer)

\*Round up to the nearest full ton

Environmental Sealing systems occupy tonnage equal to one-tenth of the structure's CF times its number of levels in height (rounded up to the nearest full ton), per hex of structure. All hexes of a Mobile Structure must receive this modification.

**Modular Structure Linkage:** Mobile Structures designed to link up with other Mobile Structures of identical motive types and speeds must incorporate additional equipment to serve as the linkage between themselves and other modular Mobile Structures. A linkage system is required on both sides, so the linkage for one Mobile Structure must mate with the linkage of its companion units. (Once linked in this fashion, the Mobile Structure is treated as a single unit with the same motive type and MP rating, but if the motive system for one of the linked structures is crippled somehow, the entire united structure becomes crippled until it can break the links.)

Modular Structure Linkage occupies tonnage equivalent to half the Mobile Structure's CF (rounded up to the nearest full ton), and must be placed in the desired "linkage" hexes (which may only be chosen from among the structure's outermost hexes). A Modular Structure may incorporate multiple Modular Structure linkage systems to build bigger unified structures. Each system also adds 4 non-officer crewmen to the unit's base crew minimum.

If a Mobile Structure's linkage hex is destroyed in game play, any connection between Modular Structures through that link is broken. Adjacent hexes may thus incorporate linkage systems in order to provide some redundancy in the event of disaster.

**Tech Base:** Environmental Sealing and Modular Structure Linkage systems are equally available to Mobile Structures built using a Clan or Inner Sphere technology base.

*Nicholai sees his superfreighter as a Modular Mobile Structure, and decides to place two linkage systems on the unit, one in the hex he designates as the unit's foremost hex and the other at the opposite end. For his 75 CF structure, these systems will each weigh 38 tons (75 CF x 0.5 = 37.5, round up to 38), and take up that tonnage in the designated hexes. As these hexes are not those reduced by the fuel tank storage, he finds that the remaining internal tonnage capacity of the affected hexes will be 1,101 tons (1,139 tons - 38 tons = 1,101 tons). Nicholai also notes that, per the rules regarding crew, these linkage systems will add 8 more crewmen to his minimum needs, which raises the officer needs to 5 ([40 base non-officer crewmen + 8 linkage crewmen] = 48; 48 ÷ 10 = 4.8 officers, round up to 5).*



INTRODUCTION

ADVANCED  
GROUND MOVEMENT

ADVANCED  
COMBAT

ADVANCED  
BUILDINGS

ADVANCED  
SUPPORT  
VEHICLES

GENERAL  
RULES

ADVANCED  
SUPPORT VEHICLE  
CONSTRUCTION

ADVANCED  
WEAPONS  
AND EQUIPMENT

INDEX

RECORD SHEETS



Paul decides not to incorporate special enhancements into his airbase.



Raymond decides to build his DropShip-mover with Environmental Sealing. With its CF of 150 and its height of 4 levels, he computes that the weight of this equipment will subtract 60 tons from each hex of the Mobile Structure ( $[150 \text{ CF} \times 0.1] \times 4 \text{ levels} = 60 \text{ tons}$ ). This will reduce the per-hex internal weight capacity of the mover to 508 tons ( $568 - 60 = 508 \text{ tons}$ ).



## STEP 3: INSTALL ARMOR

Fortress-type Mobile Structures may add armor to better reinforce them and protect them against heavy weapon fire and other major structural damage. This armor effectively adds a second layer of points that protect the CF in game play, in much the same way as a BattleMech's armor protects its internal structure.

The maximum number of armor points (per hex) that may be placed on a Mobile Structure is equal to the Construction Factor (CF) of the unit itself. When mounted on a Mobile Structure, the same number of armor points applies for all hexes of the unit, so a Mobile Structure that is assigned 112 armor points on one hex must assign 112 armor points to all of its hexes.

On Inner Sphere-made Mobile Structures, every 16 points of armor (or fraction thereof) mounted per hex subtracts 1 ton from the internal weight capacity of that hex. Clan-made Mobile Structures lose 1 ton of internal weight capacity for every 20 points of armor (or fraction thereof) mounted per hex.

Under these rules, only Fortress-type Mobile Structures may install armor of any type. Building- and Hangar-type structures lack the specially reinforced framework and structural design necessary to support military-grade armor.

As a Hangar-type Mobile Structure, Nicholai's super-freighter may not carry armor.



Paul's flying airbase, as a Building-type Mobile Structure, also may not carry armor.



Raymond's DropShip-mover, as a Fortress-type Mobile Structure, may install armor if desired. Though he does not expect the mover to face combat, he decides to install some extra protection anyway, and devotes 2 tons (per hex) to armor. This gives each of the mover's hexes 32 points (16 points per ton  $\times$  2 tons = 32 points) of extra armor protection and leaves it with 506 tons of internal capacity per hex ( $508 - 2 = 506$ ).



## STEP 4: INSTALL WEAPONS, HEAT SINKS, AND EQUIPMENT

Once the size, shape and class of the Mobile Structure is established, and its power and motive systems have been installed, any leftover internal tonnage capacity may be used to install weapons, heat sinks and other equipment as desired.

The weapons, ammunition and equipment that may be mounted on Mobile Structures are listed in the Master Weapons and Equipment Tables beginning on p. 404. In addition to any heat, damage and range statistics, these tables provide the weight these items take up on such units, what technology base (Clan or Inner Sphere) is required to use them, and any special construction rules that might apply to installing the equipment (such as location and unit type restrictions).

Remember that the total weight for a given Mobile Structure's power systems, motive systems, armor, heat sinks, weapons and other components must never exceed the internal weight capacity of the total unit, nor may the total tonnage for all items installed in a given hex of the Mobile Structure exceed the internal weight capacity of that hex. Any leftover weight (per hex) is automatically allocated to cargo space.

For special rules on any item, consult its entry under *Heavy Weapons and Equipment* (see pp. 201-245, *TM*). Rules for the additional advanced items described in this book are found beginning on p. 274.

**TechManual Items:** The Weapons and Equipment items described and listed in the tables in *TechManual* may all be mounted on Mobile Structures in accordance with their standard equipment rules. Mobile Structures may install any item permitted on tournament-legal DropShips or Support Vehicles.

**Light and Medium Weapons:** Lighter Mobile Structure types, such as Buildings and Hangars, may mount Medium and Small weapons (those usable by conventional infantry units), to a maximum limit of 6 such weapons per level of structure height—as long as they have sufficient tonnage available in the hex to do so.

**Heavy Weapons:** Only Fortress-type Mobile Structures may mount Heavy weapons (weapons that individually weigh half a ton or more). The maximum tonnage of such weapons that may be mounted per hex—discounting ammunition, turret mechanisms and heat sinks or power amplifiers—is equal to the Fortress' CF divided by 10. The weight of these weapons, plus any turrets, power amplifiers, heat sinks or ammunition, counts against the structure's weight capacity as per normal equipment.

Heavy weapons may be mounted on Mobile Structures either in turrets along the roof of the structure (see *Turrets/Pintles*, p. 267) or along the structure's outer walls. If mounted along the walls, the designer must not only note the hex the weapon is placed in, but also its level in height along the wall for line of sight purposes. (Remember that ground-based Mobile Structures stand 2 levels taller than their base height, but cannot mount weapons and equipment below a height of 3, so a weapon mounted in the lowest level of a ground-based Mobile Structure with a base height of 5 levels would be firing from a height of 3 levels, while one placed on the same Mobile Structure's roof would have an effective height of 8 levels above the ground.) Weapons mounted



in a rooftop turret are considered to have a height equal to the Mobile Structure's highest level for line of sight purposes.

**Capital Weapons:** Capital-class and Sub-capital-class weapons may be mounted on Fortress-type Mobile Structures, but the size of these weapons and the slow-moving nature of these units makes the use of such weapon systems exceedingly rare.

For capital-grade weapons, Mobile Structures that do not employ Fission or Fusion power systems may employ only capital missile launchers. Mobile Structures powered by Fission or Fusion power systems may mount other capital-scale weapon systems, but must add an extra 10 percent to the weapons' weight in order to do so, to reflect increased fire control systems and stabilizers necessary for firing.

A given hex of Mobile Structure may accommodate only 1 non-missile capital weapon, or as many capital missile launchers as the hex's tonnage will allow. Mounting any capital weapon, however, automatically precludes the installation of turrets or pintles in the same hex (or any item that is said to occupy turret space, such as Flight Decks and the like). If a desired hex does not have enough internal weight capacity to support a desired capital weapon, the weapon's tonnage may be divided as evenly as possible between the desired hex and all Mobile Structure hexes immediately adjacent to it (in which case, the same turret and pintle mount limitations apply to the adjacent hexes as well as to the central hex).

**Power Amplifiers:** As with Combat and Support Vehicles, Mobile Structures not powered by Fission or Fusion engines will require power amplifiers for any heavy energy weapons mounted on them. Such power amplifiers weigh 10 percent of the weight of all applicable weapons (rounded up to the nearest .1 ton). Power amplifiers do not count toward the weight of any weapons slaved to a targeting computer, nor do they count toward the weight of any turret or pintle mechanisms mounted on the Mobile Structure, but their weight must be assigned to the hex locations where their related weapons are mounted.

**Mobile Structure Firing Arcs:** Unless mounted on a Pintle or Turret (see below), all non-capital weapons placed on a Mobile Structure receive a fixed firing arc based on their mounted location. For all non-capital weapons mounted on an outer wall, this arc covers a maximum of 3 adjacent hexsides facing outward from the structure itself (akin to a BattleMech's forward firing arc; the actual hexsides must be chosen and identified by the designer at construction). Any hexside that faces another hex of the same Mobile Structure—adjacent or otherwise—may not be designated as part of a weapon's firing arc (so a Mobile Structure cannot be designed with weapons that turn on itself).

Capital weapons—including capital missile launchers and sub-capital weapons (see p. 343) receive a special upwards-facing firing arc when assigned to Mobile Structures, and thus do not receive a firing arc that can be projected onto a ground battle. No capital-scale weapon system installed on a Mobile Structure may be placed in a turret or pintle mount.

**Turrets/Pintles:** All Mobile Structures may install turrets, but are limited to a maximum of 1 turret per hex of unit size. Turrets may carry Light, Medium, or Heavy weapons, and are automatically located on the roof of a Mobile Structure, where they receive a height equal to that of the structure's highest level for line of sight purposes. Mobile Structure turrets have a 360-degree field of fire against any targets at or above the

Mobile Structure's uppermost height (including the 2 added levels ground-based Mobile Structures receive from their motive systems), which effectively enable them to cover the structure's entire roof in order to repel any potential boarding parties. Mobile Structure turrets may also engage any targets located below the turret's height, so long as the line of sight between the turret and its target does not pass through another of the Mobile Structure's own hexes.

Some items that may be mounted on a Mobile Structure—such as Helipads, Flight Decks and Landing Decks—may occupy "turret space" as well as internal equipment space. In such cases, the unit must designate the hexes these items occupy. Turrets may not be mounted in these designated hexes.

Pintle mounts are available only for Light and Medium weapons. These mounts may be assigned to any level in a Mobile Structure's height (except for the bonus 2 levels provided by a ground-based Mobile Structure's motive system), and receive a firing arc that runs up to 4 adjacent hexsides facing outward from the structure itself. As with wall-mounted arcs, pintles may not fire into any hex that faces another hex of the same Mobile Structure—adjacent or otherwise.

Turrets and pintles mounted in Mobile Structures receive no additional armor or structure points, and neither weapon mounts are treated as separate hit locations in combat. The weight of a turret mechanism is equal to 10 percent of the weight of all equipment mounted within it (rounded up to the nearest half-ton), discounting any heat sinks, power amplifiers, or ammunition required by any turret-mounted weapons and equipment. Pintles, meanwhile, have a weight equal to 5 percent of the weight of all equipment mounted within (rounded up to the nearest kilogram), excluding ammunition. Turret and pintle weights always count against the internal weight capacity of the hex within which such mounts are located.

**Heat Sinks:** Regardless of the power system chosen, Mobile Structures receive no free heat sinks. Mobile Structures without a Fission or Fusion power system must incorporate enough heat sinks to cover the heat generated by all energy weapons fired together. These heat sinks may be distributed as desired to the weight capacity of any hex or hexes on the unit—be it in one big lump, or in portions spread across the entire structure.

**Fire Control Systems:** Mobile Structures need not invest in fire control systems, as they receive such systems automatically when mounting any weapons. The only need for added fire control arises when employing non-missile capital-scale weapons; in which case, see the above rules for mounting capital weapons on Mobile Structures.

**Small Items on Mobile Structures:** Mobile Structures rarely employ small items, as many of the unit's amenities include such features by default, but if a designer opts to install Small-size items on a Mobile Structure, the same rules for mounting small items on Medium and Large Advanced Units apply (see p. 255).

**Tonnage-Based Items:** Some items (such as Lift Hoists) derive their strength, capabilities and damage from the tonnage of the unit that mounts them. In the case of Mobile Structures, the CF of the structure may be used in place of the unit's tonnage to define the upper limits of these capabilities (so a Mobile Structure with 100 CF and a single Lift Hoist in the hex—which can lift half its user's weight—can lift 50 tons; multiple Lift Hoists in the same hex can increase this capacity as multiple Hoists would on a single-hex unit).

INTRODUCTION

ADVANCED  
GROUND MOVEMENT

ADVANCED  
COMBAT

ADVANCED  
BUILDINGS

ADVANCED  
SUPPORT  
VEHICLES

GENERAL  
RULES

ADVANCED  
SUPPORT VEHICLE  
CONSTRUCTION

ADVANCED  
WEAPONS  
AND EQUIPMENT

INDEX

RECORD SHEETS



**Quantity-Limited Items:** As multi-hex units, Mobile Structures may exceed the standard per-unit limits of items restricted to a set quantity per unit. In this case, the structure may mount as many such items *per hex* as smaller units may mount per unit. (For example, Lift Hoists, which are limited to 4 per unit under standard construction rules, may be mounted 4 per hex on a Mobile Structure. Turrets, which are limited to 1 per unit under standard construction, may be placed 1 per hex on a Mobile Structure—as noted above.)

**Multi-Hex Items:** Items that take up multiple hexes (or multiple turret slots on large Support Vehicles) break up their tonnage evenly among the hexes of the Mobile Structure that they occupy (round fractional tonnages up to the nearest .5). These hexes must be consecutive. For example, a Flight Deck (which weighs 2,500 tons and takes up 4 turret spaces on a Support Vehicle) will occupy 4 adjacent hexes on a Mobile Structure and take up 625 tons of internal capacity per hex (2,500 tons ÷ 4 hexes = 625 tons per hex).

**Crew Quarters:** Mobile Structures of all types and classes receive any needed crew quarters free with their design, and therefore need not allocate tonnage to personnel quarters. Quarters for passengers may be added to reflect an extra level of comfort and support, but these are not required.

**Transport Bays and Doors:** Bays for cargo and unit transport often take up all remaining tonnage on Mobile Structures of every stripe. These bays can be specific cubicles for 'Mechs, fighters and other units, or they may be generic cargo bays to store supplies, spare parts or even additional ammunition and fuel stores. How much of the generic cargo space is allocated to such needs is entirely up to the designer and can vary from mission to mission, so they need not be addressed during construction.

Designers of Mobile Structures must assign a minimum of 1 bay door to any unit with a transport bay, to allow for entry and egress from the unit. A Mobile Structure can designate half of its total number of outward-facing hexsides (rounded down) and place 1 bay door in each (so a Mobile Structure that occupies one central hex and all adjacent hexes in a circular shape has a total of 18 outward-facing hexsides, 9 of which can include bay doors). If the Mobile Structure is built as a Hangar-type structure, the unit may place 2 bay doors per designated hexside, effectively doubling its bay door capacity.

A Mobile Structure's launch rate (per turn) for onboard fighters or other launch-capable units with appropriate cubicles (Small Craft, 'Mechs and ProtoMechs) is equal to twice the number of functioning bay doors associated with said launch-capable units. For example, a Mobile Structure with 18 vehicles in a single fighter transport bay that has 2 doors assigned to it may release 4 of these 18 vehicles per turn (2 doors x 2 vehicles per door per turn = 4 vehicles per turn).

Bay doors in linkage hexes that are joined to another Mobile Structure may not be used.

As a Hangar-type Mobile Structure, Nicholai's super-freighter may not carry heavy weapons. This is fine by him, as he does not plan to arm his super-freighter for combat (escort ships can handle that job, if need be). He also notes that the internal capacity for 2 of the vessel's 20 hexes—where the fuel tanks are—is 404 tons each, while 2 others—designated as linkage hexes—have a capacity of 1,101 tons. The remaining 16 hexes can hold up to 1,139 tons each.



Nicholai decides to spend his tonnage conservatively, to maximize his internal cargo capacity. He opts to place four Lift Hoists per hex (at 3 tons per hoist) along the 4-hex long left and right sides of his unit (the sides not already featuring modular linkage systems, where internal capacity is still at 1,139). In these same hexes, he also opts to place 2 maritime Life Boats (1 ton each), a mounted searchlight (0.5 tons each) and pintle-mounted 2-shot SRM Launchers (the Medium-class infantry weapon) with 50 rounds each (30 kg per weapon + 1,000 kg per 50 shots [20 kg/2 shots] + 1.5 kg per pintle mount [30 kg x 0.05 = 1.5 kg] = 1,031.5 kg, rounded up to 1.5 tons per weapon, ammo, and mount). Leaving the rest of the side hexes for standard cargo, Nicholai finds these hexes can store up to 1,123 tons each (1,139 – 12 [4 Lift Hoists] – 2 [Life Boats] – 0.5 [Searchlight] – 1.5 [SRM Pintles] = 1,123).

Nicholai also decides to install four helipads on his Mobile Structure, locating 1 each in two of the untouched forward hexes and 2 more in the untouched aft hexes. At 500 tons per helipad, these 1,139-ton hexes are reduced to 639 tons of capacity. In these same hexes, he also establishes two Light vehicle bays to store any visiting helicopters (at 50 tons each, this further reduces the internal capacities of the hexes to 539 tons).

In the internal hexes where the fuel tanks are (and where spare tonnage is lowest at 404 per hex), Nicholai decides to add passenger facilities, communications, kitchens and MASH equipment, for the well-being of his crew and any guests. He decides to install (in each hex): 20 second-class Passenger quarters (7 tons each), 3 tons of Communications Equipment, a Field Kitchen (3 tons) and a MASH unit with 4 operating theaters (6.5 tons). Together, all this equipment reduces the remaining capacity of the hexes to 251.5 tons each (404 – [(20 quarters x 7) + 3 communications + 3 field kitchen + 6.5 MASH] = 251.5).

Nicholai decides to stop adding equipment now and looks into his remaining storage capacity. In the 8 side-most hexes, he determines he has 1,123 tons per hex. In the 2 forward and aft linkage hexes, he finds he has 1,101 tons remaining per hex. In the side-fore and side-aft hexes (the 4 hexes where the helipads went), he finds he has 539 tons remaining per hex. In the 2 inner-most hexes (where the fuel tanks and quarters went), he has 251.5 tons per hex. He has not touched the 4 remaining hexes since installing motive and power systems, leaving those with 1,139 tons of capacity each. This gives his super-freighter a grand total of 18,401 tons of internal cargo capacity for this single module of what could be a long linked Mobile Structure vessel ([8 x 1,123] + [2 x 1,101] + [4 x 539] + [2 x 251.5] + [4 x 1,139] = 18,401).

He also notes that the gunners for his Medium weapons raise the number of crewmen he needs by 8 (1 Medium weapon mount per hex, times 4 hexes at a side), while the 4 helipads add 20 crew (5 apiece), the communications gear adds 6 crew (3 per 3-ton systems in each hex), the 2 kitchens add 6 more and the 8 total MASH operating theaters add another 40. Together, this raises the non-officer crew to 128, and the number of officers has thus also risen to 13 (48 crew + 8 gunners + 6 communications crew + 6 kitchen staff + 40 medics = 128; 128 ÷ 10 = 12.8 officers, rounded up to 13). All quarters for these crewmen are free with the Mobile Structure's design.

For cargo egress when docked, Nicholai finds that his Mobile Structure (as a Hangar-type structure) can designate up to 7 hexes for bay doors (half of the 14 outermost hexes it boasts). As a Hangar-type Mobile Structure, these hexsides can



accommodate 2 bay doors each, for a total of 14 doors. For symmetry, Nicholai opts to designate 3 hexes on each side of the unit for bay doors, assigning 2 doors to each one. He also selects the forward-most hex as his seventh bay door hex, even though it cannot be used if the vessel is linked to another one at the time. As with the other door hexes, he places 2 bay doors here for a total of 14 bay doors.

Paul's flying airbase currently has an internal weight capacity of 397.5 tons per hex. Though this would preclude the flight decks and helipads Paul might have initially planned on for a flying airbase, he opts to use arresting hooks to retrieve aircraft, launching them via fighter bays in the same fashion as DropShips. He thus chooses the two central hexes along each side facing on his wedge-shaped structure to contain 2 Arresting Hoists (3 tons apiece) in each hex for fighter retrieval, while 2 Aerospace Fighter bays (at 150 tons each) are assigned to the three "point" hexes of the structure (with 2 bay doors placed in 2 of these hexes' 4 outward sides for launching).



To serve as a command and control center for the base and its fighters, Paul places 6 tons of Communications Equipment in the airbase's central hex, as well as 2 20-ton Mobile Field Bases for fighter service and repair, a 4-theater MASH for tending to any wounded pilots and crew (6.5 tons) and a Field Kitchen (3 tons) for airbase personnel and their resident pilots and techs. Finally, he adds a 5-ton Look-Down Radar system, to help the airbase double as a kind of mobile surveillance unit.

The added equipment produces a need for 39 additional crewmen (6 for communications + 10 for 2 mobile field bases + 20 for the 4-theater MASH + 3 for the field kitchen). Combined with the 40 non-officer crewmen established earlier, this also raises the officer requirement to 8 ( $[40 \text{ base crew} + 39 \text{ additional crew}] \div 10 = 7.9$  officers, rounded up to 8). Quarters are not needed for these 87 crewmen and officers. However, for the comfort of the fighter pilots, their techs and any other VIP visitors, Paul adds 2 second-class Passenger quarters to the same side hexes in which he placed the arresting hooks. The quarters weigh 7 tons each.

For a final touch, Paul adds three mounted searchlights to his airbase, going so far as to place them in turrets at the structure's three points (for a total of 1 ton each—0.5 tons for the Searchlights and 0.05, rounded up to 0.5, for the turret mechanisms). He also places 2 Aerospace Life Boats in these hexes (at 7 tons each), for emergency egress should the structure be endangered.

Computing the remaining weight (which will all be treated as standard cargo), Paul finds that the three "point" hexes will have 82.5 leftover tons for cargo ( $397.5 - [(2 \text{ Aerospace Fighter bays} \times 150 \text{ tons}) + (2 \text{ aerospace Life Boats} \times 7 \text{ tons}) + (1 \text{ Mounted Searchlight with Turret at 1 ton})] = 82.5$  tons). Each of the 6 side hexes between these points has 377.5 tons remaining ( $397.5 - [(2 \text{ Arresting Hoists} \times 3 \text{ tons}) + (2 \text{ second-class Passenger quarters} \times 7 \text{ tons})] = 377.5$  tons). The remaining hex, in the unit's center, has a cargo capacity of 337 tons ( $397.5 - [(6 \text{ tons of communications gear}) + (2 \text{ Mobile Field Bases} \times 20 \text{ tons}) + (6.5 \text{ tons for 4-theater MASH}) + (5 \text{ tons Look-Down Radar})] = 337$

tons). Deciding that this central hex will house fuel reserves for the aerospace craft, Paul opts to designate the entire central cargo area as a liquid fuel storage bay. This means the 337-ton storage tonnage will be able to hold up to 306 tons of fuel and other liquids ( $337 \text{ tons} \div 1.1$  [Liquid storage takes up 1.1 times the weight of the liquid being stored] = 306.364 tons, round down).

For his DropShip-mover, Raymond has one and only one primary mission: carrying DropShips. To do this, he needs to make use of the Landing Deck, which takes up 500 tons per hex, and will preclude the use of turrets in all hexes it occupies. Ray decides that the Landing Deck will have a radius of 2 hexes from the center, effectively covering the entirety of his Mobile Structure with it. Thus, all 19 hexes of the Mobile Structure are reduced to an internal tonnage capacity of just 6 tons ( $506 \text{ tons} - 500 \text{ tons} = 6$ ). Along the 6 "point" hexes, he adds 2 Lift Hoists for cargo loading and offloading. At 3 tons each, these hoists reducing the free tonnage of these apex hexes to 0 ( $6 - [2 \text{ hoists} \times 3 \text{ tons}] = 0$ ). Along each side hex, Raymond adds a mounted searchlight (for nighttime driving) at 0.5 tons, reducing the cargo capacity of the non-apex outer hexes to 5.5 tons.



The 19-hex platform will also increase his crew needs by 57 (19 Landing Deck hexes  $\times$  3 crew per hex = 57), which brings the total non-officer crew count up to 141, with an officer requirement of 15 ( $84 \text{ base crew} + 57 = 141$ ;  $141 \div 10 = 14.1$ , round up to 15). The basic accommodations for these crewmen are included in the Mobile Structure's design.

With only 6 tons of cargo capacity per interior hex, 0 tons per "point" hex and 5.5 tons per side hex, Raymond decides to call his DropShip mover complete. Even though, as a Fortress-type structure, he could add some anti-Mech weapons to the outer hexes, he decides that the lack of tonnage and the structure's intended role as a simple DropShip mover make it ill-suited to a combat role.

## STEP 6: COMPLETE THE RECORD SHEET

By the time the designer has chosen all the design specs and equipment for his Mobile Structure, and added armor, weapons and equipment, all items must be allocated to their proper places on the appropriate Blank Record Sheet. For a completed Record Sheet, the designer must make sure to have selected the Mobile Structure sheet. The sheet must have all data filled in for the Structure Data block (including name, structure type, CF and MP values). All equipment slots must be allocated on the Weapons and Equipment Inventory (including ammunition and number of shots per bin), making certain to note which hexes all items are in as well as their facings (turreted weapons should be noted with a "(T)" and pintle-mounted weapons should receive a "(P)" notation). All extraneous hexes must be blacked out on the Mobile Structure's mapsheet diagram.

Once all of the above is completed, the Mobile Structure is ready for game play.

INTRODUCTION

ADVANCED  
GROUND MOVEMENT

ADVANCED  
COMBAT

ADVANCED  
BUILDINGS

ADVANCED  
SUPPORT  
VEHICLES

GENERAL  
RULES

ADVANCED  
SUPPORT VEHICLE  
CONSTRUCTION

ADVANCED  
WEAPONS  
AND EQUIPMENT

INDEX

RECORD SHEETS



# THE EFFICIENCY OF ROME

STEVEN MOHAN, JR.



## FOOTHILLS OF MOUNT NIJAK ILLYRIAN, ILLYRIAN PALATINATE 8 JUNE 3063

The trap had worked exactly as General Julius O'Reilly had planned. He'd hung his Auxilia Loricatus out to dry, ordering his tanks to fall back to a mountain valley whose sloping walls precluded retreat for tracked vehicles. Offered the opportunity to crush the Marian armor, the Illyrian forces bit down hard. The Right Arm of Thor and Cavanaugh's Cavalry swarmed into the valley.

And then the armor *prefect* gave the pre-arranged signal and O'Reilly's Prima and Tertia cohorts moved forward, his assault machines taking position at the top of the valley's walls and pouring a terrible, merciless fire down on the heads of the mercenaries.

O'Reilly watched his plan unfold from the vantage of his SD1-0 *Sunder*.

At first, the Right Arm of Thor stood up to the brutal beating, doggedly working their way from cover to cover.

Not Cavanaugh's Cavalry, though. They fell back.

In an instant there was not a machine left standing painted in the Cavalry's royal blue and white trim. The field was left to the gray and green mountain camo of the Right Arm of Thor. And the merciless fire of O'Reilly's cataphracti.

Thor's 'Mechs began to fall back.

O'Reilly leaned forward and said, "All units, this is Aurora. *Salvo jure*." The Latin code phrase sent O'Reilly's fast machines, his comitati, slashing forward to hit the enemy in the back or dropping into the midst of the confused retreat on plumes of argent fire. Where they were to destroy the Illyrian mercs.

*Without prejudice.*

And then, as O'Reilly watched, the momentum somehow shifted back.

It began with a single Thor *Nightsky*. The machine's insect-like cockpit and rounded torso made it look like a giant roach. Apparently this bug wasn't ready to be squashed. The machine stopped, turned and hit its jump jets, suddenly rising on three plumes of golden fire.

It came down hard, already swinging the ugly hatchet in its right arm.

Right into the cockpit of a Marian *Javelin*.

The comitati dropped like a man suddenly beheaded. The *Nightsky* pivoted and tore into a *Panther* with the large pulse laser in its left arm. The *Panther* staggered backwards, its chest armor a sudden mess.

Up and down O'Reilly's line, merc machines were turning and fighting. In seconds what should have been a rout had turned into a brutal slugfest, and



O'Reilly's comitati were getting the worst of it. The Marian lights were facing bigger and better armed 'Mechs and there was no way for his own *cataphracti* to help. The battle had raced beyond their short-range weapons and they didn't dare use their long-range weapons for fear of hitting their own countrymen.

If he didn't act quickly, he was going to lose all his striker units. "This is Aurora. All comitati fall back. All *cataphracti* and *auxilia* forward to cover their retreat."

His light machines started to retreat. If the mercs pursued, this day might still be salvaged.

At first it seemed to be working.

As one of his *Firestarters* broke for the advancing line of friendly *cataphracti*, the *Nightsky* rose on a pillar of flame. O'Reilly felt a snarl touch his lips. He dropped his reticle over the enemy medium and put his *Sunder* into a bone-crunching, earth-shaking run, pushing his 360XL for all it was worth.

The symbol flashed gold a second before the *Nightsky* touched down.

O'Reilly pulled his triggers, stitching a long stream of depleted uranium slugs across the *Nightsky's* chest and following it with a flight of SRMs from his head, then two more from his torso.

The attack must have shifted the *Nightsky's* momentum because the machine came down unbalanced on its right leg. The limb had never been designed for that kind of loading.

It snapped off.

The *Nightsky* toppled to the earth.

O'Reilly looked up, searching for another opponent, but in the time it took for him to down the *Nightsky* the enemy had melted away. The fight had been short, but no less devastating for all that. The battlefield was littered with broken machines—some painted white with blue and copper trim of his own *II Legio* and some painted in the more practical camouflage scheme of the Arms of Thor.

This should have been a decisive victory. Instead, it was a bloody stalemate. He sighed. He would have to salvage what he could.

He began to turn away, and then something made him turn back and look again. It occurred to him that he saw little of the royal blue of Cavanaugh's Cavalry mixed in with the dead.

## **MARIAN HEGEMONY POW CAMP 10 JULY 3063**

Sometime in the night, Captain Eric Larsson shifted on his bunk and bumped his left wrist, sending molten agony shooting up his arm. The ache of the broken joint was a constant presence, one he couldn't even escape in his sleep.

He dreamed of pain.

But it was nothing compared to the pain of being Dispossessed.

His *Nightsky* was eight years old, but that was practically off the showroom floor by Periphery standards. And it was his.

He closed his eyes. Not any more.

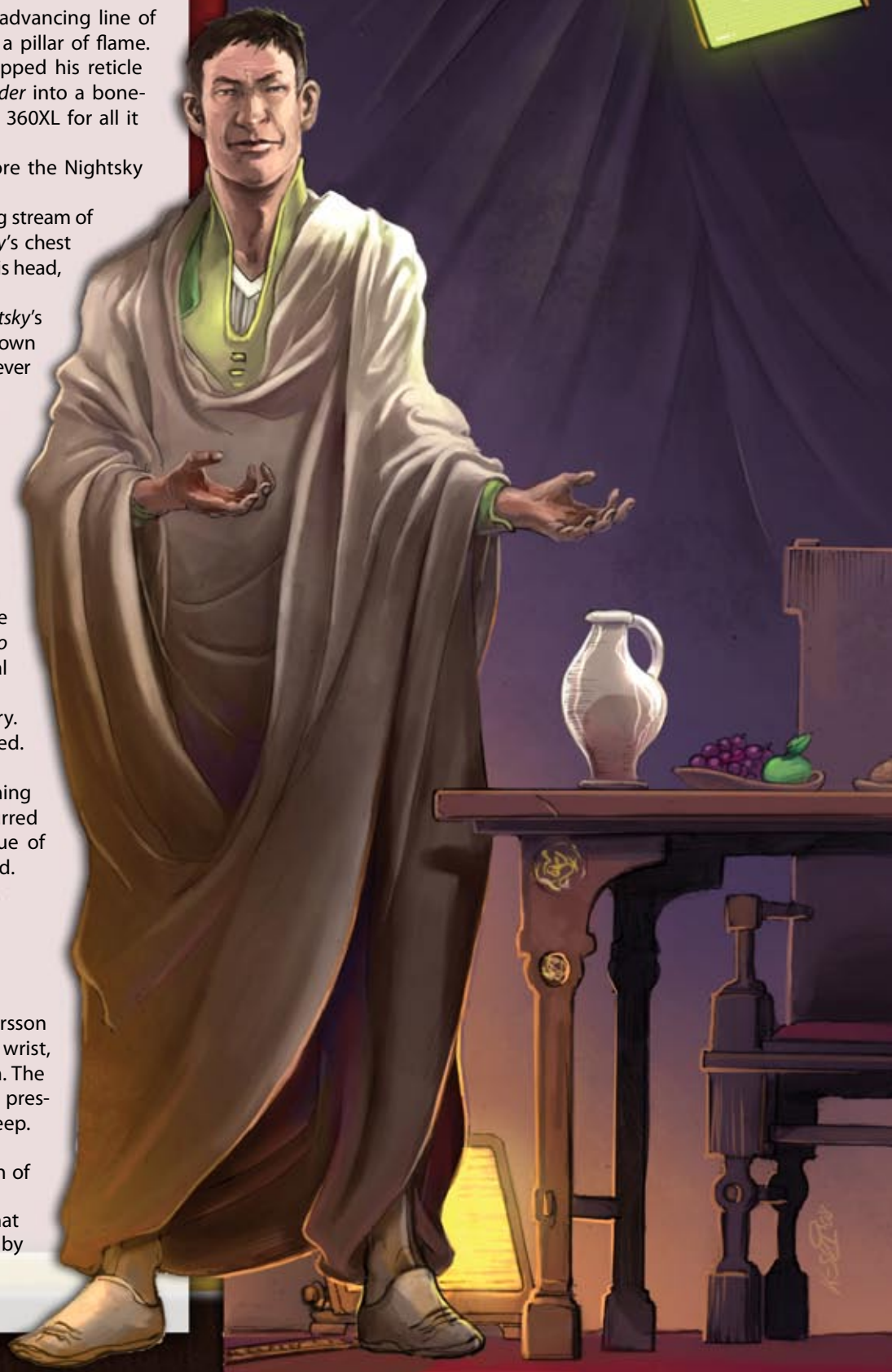

He replayed that final battle with the *Sunder* over and over again, going back to it like a child might worry a loose tooth.

Finding no solace.

The door of his cell opened, flooding the small wooden room with harsh light.

"Get up, dog," barked the silhouette in the doorway. "We're going for a ride."

## MARIAN HEGEMONY FIELD HEADQUARTERS

Larsson had no illusions about his ultimate fate. The Marian Hegemony had started as a bandit kingdom, and he knew what pirates did to prisoners. He did his best to make himself ready for death.

After they'd set his wrist, he'd allowed himself to hope that they didn't intend to torture him. He shook his head.

*Eric, you are a fool.*

They'd obviously only fixed him so they could break him again. Torture was all about contrast.

The guards wore blue infantry uniforms and carried automatic weapons at port arms. There were four of them, two ahead, two behind. Larsson considered escape, but he couldn't take four armed soldiers. Not with a broken wrist. And even if he did get away, where would he go? They'd brought him to the heart of the Marian camp. No, he'd have to see this one through.

Whatever that meant.

The soldiers led him to a large canvas tent that had been dyed royal purple. When they pulled the flap back and pushed him inside, he found himself standing on a thick, crimson carpet. Cunning lamps simulated the flickering golden glow of candles and lent the tent a touch of warmth. All the furniture was polished cherry wood inlaid with gold.

There was red wine in silver goblets, fresh greens, warm bread. He smelled the mouth-watering aroma of roasted pheasant.

Torture was all about contrast.

With an effort he jerked his attention from the food and focused on the man the soldiers had obviously brought him to see.

On the surface there was nothing remarkable about him. He was dressed in the plain, white robes of a Roman nobleman. He was young—in his early twenties—with short brown hair already starting to recede at the temple and he was on the short side of average height.

But his eyes.

They were steel gray and Larsson got the sense they missed nothing.

The man stepped forward and offered his hand. "I'm Julius O'Reilly."

"Eric Larsson." Without thinking, he shook the young man's hand. "O'Reilly?"

The man rolled his eyes in a self-deprecating gesture. "Afraid so." He glanced at the lead soldier. "That will be all, *Miles*."

The man touched his fist to his heart and departed.

"*Miles*?" Larsson asked.

"I have given my troops Roman ranks. Perhaps this tradition will catch on in the rest of the Hegemony." He smiled. "Someday."

"Someday," echoed Larsson. "When you become Caesar."

"I see you take my meaning. So you are intelligent as well as brave."

Understanding dawned. "It was *you*," Larsson said. "In the *Sunder*."

O'Reilly nodded. He stepped over to the table, selected a cherry from a bowl, popped it in his mouth. "Want something?"

Larsson shook his head. It was the hardest thing he'd ever done.

"My father is a monster," O'Reilly said softly.

"Yeah, except right now, you're the one invading my home."

O'Reilly shrugged. "I have to have my Gaul."

Larsson looked at him blankly for a moment. Then he said, "Oh, yes. Julius Caesar earned his reputation by conquering Gaul. It was his stepping stone to Rome."

"Most impressive, Captain."

Larsson swallowed, squared his shoulders. "I won't help you, O'Reilly."

O'Reilly's lips quirked. "I think you will."

Larsson shook his head emphatically. "I will not give you a single piece of military information. We are mercenaries, O'Reilly. But that does not mean we aren't patriots. We love our nation as much as any Illyrian. We will fight you to the very last man."

O'Reilly studied him for a long moment. Finally he nodded. "I believe you, sir."

"So it doesn't matter how much you torture me, I won't—"

"Who said anything about torture?" O'Reilly frowned. "Have you been mistreated in any way? I will do everything I can to make your stay with us comfortable."

Larsson shook his head. "No, I just, uh—Look. I'm not going to help you."

A bright smile lit up the young man's face. "Why, Captain Larsson, you already have helped us."

Larsson could think of nothing to say.

O'Reilly took him by the arm directed him to a campaign chair. "Please sit."

Larsson slowly settled into the chair.

"Let me tell you a story about Julius Caesar," O'Reilly said. "When he was a young man, Caesar was captured by pirates who wished to ransom him for twenty talents of gold." O'Reilly laughed. "He told them he was worth at least fifty. They got it for him, too. But here is the interesting part. While he was their captive, he warned them that once he was released he would hunt them down and crucify them. They didn't believe him, of course."

Larsson felt a chill wriggle down his spine. "But he did it," he whispered.

"Oh," said O'Reilly, disappointed. "You've heard it before."

"No, but ..." He shook his head. "What is your point, exactly?"

"Just this, Captain. No barrier can stand before the will of a great man."

"And are you a great man, General?"

O'Reilly smiled cheerfully. "You and I will just have to find out together."



And after that the four *miles* were back to take Larsson away. They walked through the Marian camp, again two in front, two in back. If O'Reilly could be believed, Larsson didn't have to worry about being tortured.

No, he'd have a nice comfortable seat for the Marian conquest of his home. *You already have helped us.*

Larsson clenched his jaw. *No. I will not give in. Not while my brothers still fight and die.*

He tripped and sank to one knee, moaning and holding his broken wrist.

One of the trailing guards leaned over to help him.

Quick as a snake, Larsson punched him in the throat. He was reaching for the man's weapon almost before he dropped it.

He heard the other soldiers shouting, "*Stop*," but he ignored them. He turned the gun on the guard next to him and pulled the trigger, feeling the submachine gun rattling in his arms, watching the man sprout black-red holes.

He fell and Larsson turned to find another target.

What he saw was the butt of a rifle swinging down into his face. And then everything went black.

## **MARIAN HEGEMONY FIELD HEADQUARTERS**

### **15 JULY 3063**

It was five days before he saw O'Reilly again. This time the guards shackled him when they led him out, but other than that no one mentioned the escape attempt. They brought him to a hotel that had been captured by the Hegemony and followed behind as he spoke with the General.

This time O'Reilly was dressed more formally: he wore a purple baldric draped over the left shoulder of his gray uniform tunic, a golden ballistic breastplate, and a gladius at his hip. Larsson wondered what the General had planned that required a dress uniform.

Was O'Reilly here to pass judgment on him?

"Are you here to inform me of my punishment?"

O'Reilly shook his head. "No. I as much as dared you to do it the last time we met, with my speech about great men and their will." He looked gravely at Larsson. "You killed a man. You will need to make restitution to his family. But there will be no punishment. You are a fighter, Larsson. I admire that. I *need* that."

"You 'need' me," Larsson said scornfully. "I'm the most useless thing in the universe: a MechWarrior without a 'Mech."

O'Reilly shook his head. "I need you more than you know. Conquest is easy. Governing is hard."

Larsson clenched his jaw. "You will not find the conquest of Illyria quite so easy."

O'Reilly shrugged. "Perhaps. I didn't ask you here to pick a fight."

"Oh," Larsson said acidly. "And just why did you ask me here?"

"Julius Caesar was not destroyed on the battlefield, Captain. He was murdered by Brutus and a band of conspirators."

"Yes," Larsson said, "stabbed on the Ides of March. I've heard that story, too."

O'Reilly shook his head sadly. "Caesar wasn't murdered with a blade. The instrument of his destruction was politics. He was dead before the first conspirator picked up a knife."

"And you'd like to avoid the same fate."

Again O'Reilly shrugged. He stopped in front of a conference room with beautiful mahogany doors. The soldiers behind Larsson stepped up to flank him.

Larsson glanced at the men. "You'll forgive me if I don't wish you luck."

Just then one of the doors swung open and a Marian officer stepped out. Larsson glanced at the open door and for just a second he glimpsed what was inside: a beautiful oak conference table with the Marian senior staff arrayed along the near side of the table and empty seat in the center, obviously intended for O'Reilly himself.

Sitting opposite them were several officers wearing the royal blue dress uniform of Cavanaugh's Cavalry, Jared Cavanaugh at their head.

"Oh," said O'Reilly. "I never leave anything to luck."

## **OUTSKIRTS OF THE CITY OF ILLYRIA**

### **19 JULY 3063**

The battle for Illyria passed close enough to the Marians' camp that Larsson heard the sounds of combat in the night: the high-pitched shriek of lasers, the whipcrack of PPCs, the deadly rattle of autocannons. He held his breath, hoping that the Right Arm of Thor would break through and smash Julius O'Reilly, but in the morning it was the same group of Marian infantry that came for him.

This time they drove him to the outskirts of Illyria's capital. Larsson knew they were drawing near the battlefield before he saw it. He could smell it in the sharp odors of oil and metal, the stench of burning grass.

The scent of blood.

Their jeep crested a hill and Larsson gasped. What he saw was a slaughterhouse. The scattered limbs of broken machines littered the scorched grass. There were Marian 'Mechs and Thor 'Mechs, but the machines of the Illyrians outnumbered the others two to one.

Larsson didn't see a single machine painted royal blue.

"Where is Cavanaugh's Cavalry?" he asked dully.

"Holding the capital," said the lead guard. "For us."

Larsson nodded. He swallowed, held up his hands. "You don't need to keep me locked up any longer."

He was surprised when the man leaned forward and unlocked his shackles. "The General said you'd say that."

They rode in silence until they reached O'Reilly's field camp, where he found the General in MechWarrior togs, his cooling vest off and a towel draped around his sweaty shoulders.

O'Reilly flashed him a sympathetic look. "Now you see the truth of it."

Larsson had to look away. He turned from O'Reilly and stared out at the field of broken men and machines. *His brothers and sisters.*

"You said—" Larsson almost choked on the words. "That I — helped you."

"You showed me the character of the Right Arm of

Thor," O'Reilly said

gently. "And when

I didn't find the

same fire and

intelligence

in Jared

Cavanaugh, I knew

he could be turned."

Larsson closed his eyes.

"You're free to go, if you like," O'Reilly said. "But I hope you'll stay."

"To what purpose," Larsson said bitterly, "*Caesar?*"

"There are many 'Mechs here that can be salvaged, rebuilt, placed again on the field. But none are so valuable as what can be salvaged among men."

Larsson had nothing to say to that. He opened his eyes, but he could not bring himself to face O'Reilly.

"Do you know what made Rome so successful, Captain?"

Numbly Larsson shook his head.

"It wasn't their legions or their aqueducts or even their roads. What made Rome mighty was its flexibility. All men were adopted into the empire no matter what they looked like, how they spoke, where they were from. This was so true that even a foreigner like Septimus Severus or the son of a freed slave like Pertinax could rise to be emperor. Think of that." He drew a deep breath. "Rome wasted nothing."

"You don't need me," Larsson whispered.

"Tomorrow," said O'Reilly, "my troops and I will begin the journey home. Once we execute that first jump, there will be no turning back. The Alphard zenith jump point is my Rubicon."

O'Reilly's voice dropped in volume, but not in intensity. "If I am to rule better than my father, I will need men like you by my side. It is, of course, your choice."

Larsson heard the General who would be Caesar turn and walk away. The former merc drew a deep, shuddering breath.

Then, after a moment, he turned to follow.

# ADVANCED WEAPONS AND EQUIPMENT

This section provides game play and construction rules for advanced weapons and equipment that may appear in Inner Sphere and Clan battlefield and support units. While they are not suitable for tournament play under the rules of *Total Warfare (TW)*, they can add more flavor to *Classic BattleTech* games that use *Total Warfare* core rules in conjunction with this rules supplement, and are designed to function in accordance with *Total Warfare* during game play (or *TechManual* during construction) unless otherwise noted.

All equipment appears in alphabetical order within its respective sections. In general, most of these items are used in the design of Battle Armor, Combat Vehicles, Support Vehicles, IndustrialMechs, BattleMechs, ProtoMechs and aerospace units of every kind (though some equipment may be exclusive to a few unit types).

While all items in this section contain both their full construction and game play rules, the expanded rules for the use of some items is not be covered under *Tactical Operations*; for example the construction rules for Advanced Rules aerospace units, such as WarShips, JumpShips and Space Stations. Those rules are found in *Strategic Operations*.

**To:** Headmaster Alfred Simms, Savonberg Elesee-Beckett  
**From:** Viscount Kenyon Stephenson, Stephenson Holdings  
**Re:** Mutual Interests  
**Date:** 07-30-75  
**Security:** [[MOST PRIVATE: ENCODED FOR RECIPIENT ONLY]]

Brother Alfred,

Forgive the unprecedented intrusion, but I think you shall find the incorporated gifts electronically enclosed to be of immeasurable value to you, your staff, and your colleagues. I caution, however, against disclosing too much, too quickly, to your peers. In these dark times, after all, it is most difficult to be certain who may be trusted and who mustn't be. I therefore have encoded this document to be unlocked by you and you alone.

To get straight to the point: Our friends have struck technical paydirt. Although the original source may be a Snake, we—and of course I mean those most trusted who share our enlightened perspective—have verified the veracity of the vast majority of these documents. The level of development is staggering, to say the very least, and points to resources and resourcefulness our enemies (and erstwhile allies) have perhaps never before displayed.

"With the loss of NAIS, the technical aspects of these developments will fall to others to implement..." Those were the words our *illustrious* Princess-Regent supposedly said when she received this information from the Snake. Naturally, of course, we thought of you and yours first. But not to be overlooked are the strategic and tactical concerns, which we are already studying. Needless to say, the possibilities are truly momentous!

Take these to heart as you review the encoded attachments. We will naturally be in touch shortly to discuss things further.

Your comrade-in-arms!  
—Kenyon

## AVAILABILITY CODES TABLE

Code	Description
AF	Aerospace Fighters
BA	Battle Armor*
BM	BattleMechs
CF	Conventional Fighters
CI	Conventional Infantry
CV	Combat Vehicles
DS	DropShips
IM	IndustrialMechs
JS	JumpShips
PM	ProtoMechs
SC	Aerospace Small Craft
SS	Space Stations
SV	Support Vehicles
WS	WarShips
MS	Mobile Structures

\*Including Exoskeletons and PA(L) units

# EQUIPMENT NOTES

Each item in this section comes with a basic description of the item and its function, followed by game play data that includes the item's rules level, Availability, Technology Base (and Tech Ratings), game rules and construction rules. This information helps identify how and by what units a given piece of equipment may be employed.

Unless the rules of a weapon or a piece of equipment specifically prohibit its use with a weapon and/or equipment, assume they are compatible.

**Rules Level:** The rules level of the advanced equipment featured here represents the prevalence of an item outside the tournament-level rules presented in *Total Warfare*, as well as whether the item exists in the mainstream of technology used by units in the *Classic BattleTech* universe. Under these rules, equipment may have either an Advanced or Experimental rules level. Advanced-level equipment represents items appropriate for advanced-level game play, which are considered well in the mainstream of technologies available to CBT units: for example, artillery, most capital weapons, flight decks and helipads. Experimental-level equipment, meanwhile, has yet to reach mass production in the CBT universe because it is prohibitively expensive, extraordinarily sophisticated, exceedingly difficult to maintain or simply deemed too unreliable or restrictive for widespread deployment. Such items—including CASE II, independent Handheld Weapons, the Null-Signature System and Sub-Compact K-F Drives—may in fact only exist on drawing boards or in forgotten first Star League caches by the year 3075, and their appearance in game play should be kept rare by players interested in following a “canonical” campaign.

**Availability:** Availability indicates what unit types may carry a given item (in broad terms) using two-letter codes shown in the Availability Codes Table below. Some items may be used by multiple unit types. For example, an Availability code listing of AF, CF, SC, DS indicates an item that may be carried only by aerospace fighters, conventional fighters, Small Craft and DropShips. However, even if an item is listed for a given unit type, specific units within that type may be unable to carry an item—for example, Docking Units (which may only be used by Naval-type Combat and Support Vehicles). Such exceptions are noted under the item's Construction Rules.

**Tech Base (Ratings):** Tech Base (Ratings) indicates whether or not a listed item is made using Inner Sphere technology (including the Star League and Periphery), Clan technology, or both. Unless using the Mixed Technologies rules (see p. 377), a unit built with a Clan tech base may use only items identified as having a Clan or Both tech base, while Inner Sphere-built units may use only items identified as having an Inner Sphere or Both tech base.

Following the Tech Base Rating, in parentheses, are the Tech Level and Availability Ratings for the item. Used most commonly in Support Vehicle construction, these ratings are given as four-letter codes of A through F plus X. The first letter expresses the item's Tech Rating, followed by a slash; the remaining three letters describe the item's Availability Ratings across three major eras (Star League, Succession Wars and Clan Era). The codes run in ascending order of technology and difficulty to acquire. For example, a Tech Base Rating of A indicates a particularly low-tech item, while an F rating indicates a highly advanced (and often experimental) piece of technology. An Availability Rating of A indicates an easy-to-find item in the selected era, while an Availability Rating of F indicates an item so rare as to be nearly unique. An Availability Rating of X indicates an item that either does not exist in a given era or is so hard to come by that it may as well not exist in that time period.

**Game Rules:** This entry provides the basic game play rules for a given item, as well as its Advanced Equipment Table reference (starting on p. 404) where players can find the item's raw statistics (such as heat, damage, range and ammunition capacity). Some items can be highly complex to employ, or may negate the effects of other equipment mounted on the same unit, forcing a unit designer to consider the effects of mounting such items.

**Construction Rules:** The Construction Rules entry notes any special construction rules for the item that cannot be described by its raw statistics or Availability codes, such as location restrictions or requirements, unit type exceptions, formulas for finding the weight for variable-weight items and so forth. Raw statistics on equipment (such as weights and critical slot information for fixed-size items) appear in the item's reference line in the Advanced Equipment Table.

**Modular (Omni) Technology:** Unless otherwise noted, all of the items presented below may be pod-mounted on appropriate modular or Omni unit types.

## A Note on Equipment Introduction and Availability

Unlike the equipment and weapons featured in *TechManual*, the items presented in this section represent less common components and design options in the *Classic BattleTech* universe. Some equipment, for example, is considered to be “Experimental” because it has yet to reach widespread production and distribution in any major or minor faction. These items, as a result, will not even feature an Introduction date in their descriptions. Other items, rendered extinct by the ravages of war or declining use over the centuries, may likewise receive the “Experimental” tag, despite having Introduction (and Extinction) dates.

Players interested in reflecting historically accurate technology use in their games should note the introduction and extinctions dates on any desired item with these explanations in mind to determine whether said item can be employed in their games.

INTRODUCTION

ADVANCED  
GROUND MOVEMENT

ADVANCED  
COMBAT

ADVANCED  
BUILDINGS

ADVANCED  
SUPPORT  
VEHICLES

GENERAL  
RULES

ADVANCED  
SUPPORT VEHICLE  
CONSTRUCTION

ADVANCED  
WEAPONS  
AND EQUIPMENT

INDEX

RECORD SHEETS

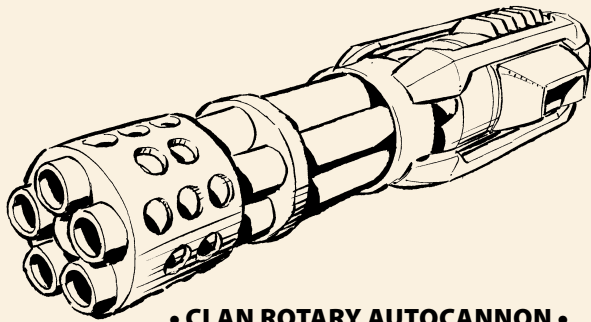

• CLAN ROTARY AUTOCANNON •  
[PAGE 286]



• BATTLEMECH MACE •  
[PAGE 290]

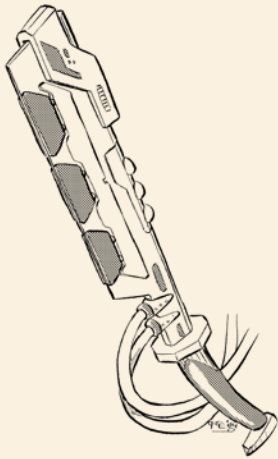

• BATTLEMECH VIBROBLADE •  
[PAGE 292]

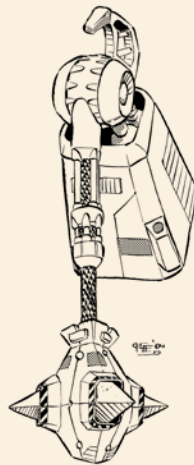

• BATTLEMECH FLAIL •  
[PAGE 289]



• BATTLEMECH SHIELD •  
[PAGE 290]

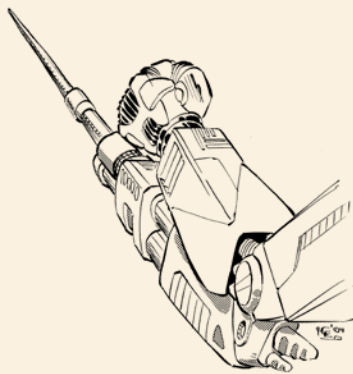

• BATTLEMECH LANCE •  
[PAGE 290]



• BATTLEMECH CLAW •  
[PAGE 289]

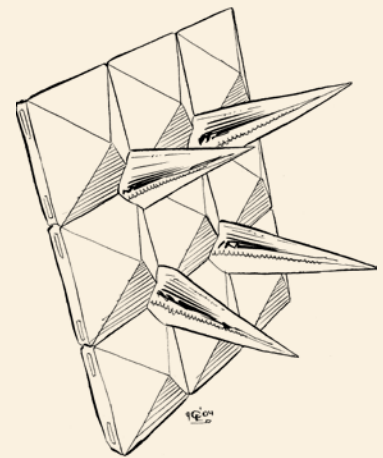

• BATTLEMECH SPIKES •  
[PAGE 290]



• **BATTLEMECH HARJEL SYSTEM** •  
[PAGE 288]



• **'MECH UMU SYSTEM**  
[PAGE 295]

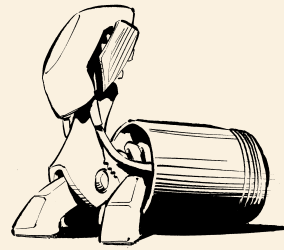

• **C<sup>3</sup> REMOTE SENSOR** •  
[PAGE 298]

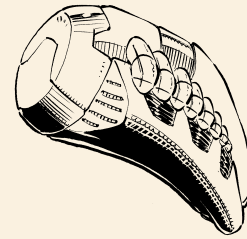

• **COOLANT POD** •  
[PAGE 303]

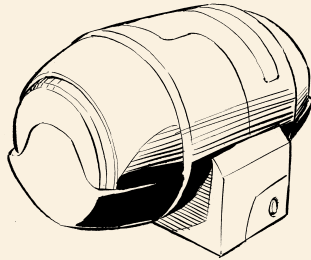

• **ENERGY STORAGE BATTERY** •  
[PAGE 306]

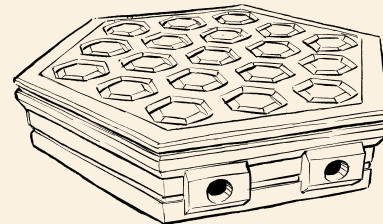

• **CHAFF POD** •  
[PAGE 299]

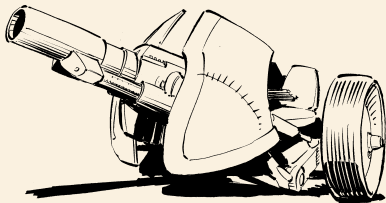

• **FIELD GUN** •  
[PAGE 311]

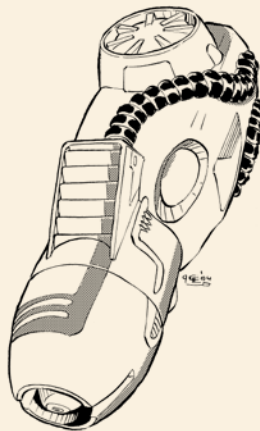

• **FLUID GUN** •  
[PAGE 313]

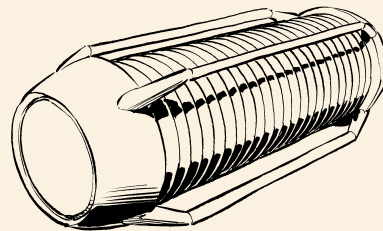

• **BLUE SHIELD PARTICLE FIELD DAMPER (PFD)** •  
[PAGE 296]



• **LITHIUM-FUSION BATTERY** •  
[PAGE 323]

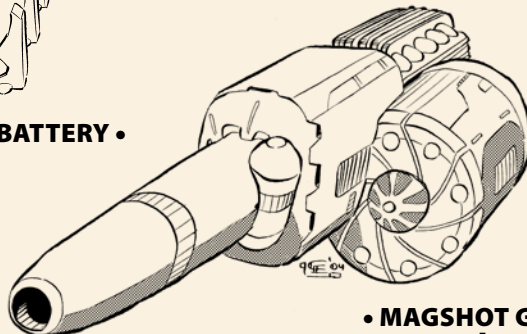

• **MAGSHOT GAUSS RIFLE** •  
[PAGE 314]

# ACTIVE PROBES

In the ongoing race to dominate the increasingly critical battlefield of electronics warfare, both the Clans and the Inner Sphere have experimented with newer and more powerful versions of the Star League-era active probes

and ECM suites. Among the most promising and effective devices still in the experimental stages are the Inner Sphere's Bloodhound Active Probe and the Clan Watchdog Composite Electronic Warfare System.

## BLOODHOUND ACTIVE PROBE

**R&D Start Date:** 3056 (ComStar)

**Prototype Design and Production:** 3058 (ComStar)

Spurred on by the arms race following the initial Clan invasion, ComStar engineers began work on an enhanced form of active probe technology

intended to combat modern ECM systems. Unfortunately, numerous setbacks—from the Word of Blake Schism to the current Jihad and ComStar's expulsion from Rasalhague space—have prevented full-scale production of this powerful piece of EW hardware.

## BLOODHOUND ACTIVE PROBE

**Rules Level:** Experimental

**Available To:** BM, IM, CV, SV, AF, CF, SC, DS, MS

**Tech Base (Ratings):** Inner Sphere (E/X-X-F)

**Game Rules:** The Bloodhound Probe is an upgraded version of the Inner Sphere's Beagle Active Probe and follows the same rules as that device (see p. 129, *TW*). In addition to boasting increased range, the Bloodhound can detect hidden units with stealth or sneak ability, including Battle Armor units with Stealth Armor, Mimetic Armor and ECM, as well as other units featuring ECM, Null-Signature Systems or Stealth Armor. Unless the unit's ECM rules state otherwise, or the unit is conventional infantry using ECM or stealth systems, the Bloodhound will detect it.

Units with multiple active probes (of any type) may use only one at a time in game play. (These systems can be activated, deactivated or switched over during the End Phase of any turn.) Fighters, Small Craft, DropShips and other airborne units may only use active probes when interacting with ground units, or in accordance with the advanced rules for aerospace combat covered in *Strategic Operations*.

## WATCHDOG COMPOSITE ELECTRONIC WARFARE SYSTEM (CEWS)

**R&D Start Date:** 3057 (Clan Smoke Jaguar)

**Prototype Design and Production:** 3059 (Clan Smoke Jaguar)

In their final years, Clan Smoke Jaguar initiated a number of new programs aimed at reinforcing their Touman and negating the Inner Sphere's few tactical edges over Clan technology. Targeting the area of electronic warfare was the so-called Composite Electronic Warfare System (CEWS)

that Inner Sphere intelligence dubbed the Watchdog. A combination of the Clan active probe and ECM suite, this device promised the benefits of both in a single compact package, and would allow a given Clan unit to devote the saved weight to additional weapons or armor. The Jaguars' demise saw prototypes of the system eventually scattered among various Clans, but none have yet distributed a production-quality version.

## WATCHDOG COMPOSITE ELECTRONIC WARFARE SYSTEM (CEWS)

**Rules Level:** Experimental

**Available To:** PM, BM, IM, CV, SV, AF, CF, SC, DS, MS

**Tech Base (Ratings):** Clan (F/X-X-F)

**Game Rules:** In an effort to streamline their electronic warfare packages, the Clans developed the Watchdog as a one-piece combination of a light active probe and ECM suite. The system works in the same way as the Clans' standard ECM and Light Active Probes (see pp. 129 and 134, *TW*), but lacks the range of the Clan-made systems.

Units with multiple ECM suites (of any type) may use only one at a time in game play. (These systems can be activated, deactivated or switched over during the End Phase of any turn.) Fighters, Small Craft, DropShips and other airborne units may only use ECM suites when interacting with ground units, or in accordance with the advanced rules for aerospace combat covered in *Strategic Operations*.

For units equipped with Stealth Armor systems, the Watchdog can be used in place of the Guardian ECM for the same effect, using the same rules.

**Active Probe:** The Bloodhound Active Probe and the Watchdog System may be mounted on any available unit type in accordance with the unit's standard construction rules.

**Actuator Enhancement System (AES):** May only be installed in a BattleMech or IndustrialMech's arm or leg locations. Only one can be mounted in each limb. Leg-mounted AES components require that all of the unit's legs receive this equipment (so a Humanoid 'Mech must mount two leg AES components, while a Quad 'Mech must mount 4—with each unit placing 1 component in each leg). Arm-mounted AES components need not be mounted in both arms, however (so a 'Mech may install an AES in the left arm, leaving the right arm unmodified). For humanoid 'Mechs, the weight of each AES equals the 'Mech's total weight, divided by 35, rounded up to the nearest half-ton. Four-legged 'Mechs divide the 'Mech's weight by 50 and round up to the nearest half ton to find each AES component's weight.

Regardless of tonnage, each AES component occupies 1 critical slot per weight class (1 slot for light 'Mechs, 2 for medium 'Mechs, 3 for heavy 'Mechs and 4 for assault 'Mechs), which may be placed only in the affected leg or arm locations. Heavy and assault 'Mechs thus cannot mount AES components in the legs (heavy and assault four-legged 'Mechs cannot use of an AES). AES components may not be pod-mounted and so may only be employed by OmniMechs if installed as part of the design's base configuration. AES components are incompatible with MASC, Triple-Strength Myomer (of any type) and Targeting Computers, and so cannot be mounted on units that employ these systems.

**Angel ECM Suite:** The Angel ECM Suite may be mounted on any available unit type in accordance with its standard construction rules.

# ACTUATOR ENHANCEMENT SYSTEM (AES)

**R&D Start Date:** 3067 (Blackwell Corporation/Wolf's Dragoons)

**Prototype Design and Production:** 3070 (Kell Hounds/Wolf Dragoons)

The Actuator Enhancement System (AES) is a combination of finely tuned myomer bundles and an enhanced DI computer interface that can improve the workings of a BattleMech's limbs. In many ways similar to the acuity-

enhancing servos and mechanisms tied into enhanced targeting computers, AES components serve to stabilize subtle variances in gross 'Mech movements, which can lead to greater weapon precision or improved balance adjustments. However, the systems are heavy and bulky.

## ACTUATOR ENHANCEMENT SYSTEM (AES)

**Rules Level:** Experimental

**Available To:** BM, IM

**Tech Base (Ratings):** Both (E/X-X-F)

**Game Rules:** An Actuator Enhancement System mounted in the arm provides a -1 to-hit modifier for all weapons mounted in the same arm location, as well as a -1 to-hit modifier for all Physical Attacks using only that arm. (For Physical Attacks that require both arms, the -1 to-hit modifier only applies if *both* arms mount a functioning AES.) When mounted in the legs, the AES provides a -2 modifier to all Piloting Skill Rolls (except Physical Attacks, which receive only a -1 modifier). Weapons split between an arm and torso location gain no bonus from an AES.

Actuator Enhancement Systems are considered active at all times during game play until the unit is destroyed or the AES component suffers a critical hit. AES leg units lose all AES-provided modifiers if any of the unit's leg-based AES components suffer critical damage; arms only lose the AES-provided modifiers if the system in the affected arm takes a critical hit.

# ANGEL ECM SUITE

**R&D Start Date:** 3053 (Draconis Combine), 3056 (Clan Goliath Scorpion)

**Prototype Design and Production:** 3057 (Draconis Combine),  
3058 (Clan Goliath Scorpion)

Derived from captured Clan technology, research on the Angel ECM Suite began shortly after the Battle of Luthien as part of an effort to counter the increasingly sophisticated electronic warfare systems of the modern battlefield. Essentially a boosted, broader-spectrum version of the Guardian ECM,

the Angel was shelved numerous times due to cost overruns and ultimately saved only with aid from ComStar. Internal problems in the Combine and ComStar derailed development of this device, which has yet to reach full-scale production—but not before Clan scientists, catching wind of this effort, launched a similar project of their own.

## ANGEL ECM SUITE

**Rules Level:** Experimental

**Available To:** BM, IM, CV, SV, AF, CF, SC, DS, MS

**Tech Base (Ratings):** Both (F/X-X-F)

**Game Rules:** The Angel ECM Suite works like standard ECM (see p. 134, *TW*), but can also block the Bloodhound Active Probe, Artemis V and C3 Booster Systems, and even negates the locking systems of Streak missiles. Streak missiles fired into or through a hostile Angel ECM bubble will not fire if the to-hit roll fails, but on a successful Streak launcher attack, the attacker must roll on the Cluster table as though the launcher were a standard (non-Streak) model.

Units with multiple ECM suites (of any type) may use only one at a time in game play. Fighters, Small Craft, DropShips and other airborne units may only use ECM suites when interacting with ground units, or in accordance with the advanced rules for aerospace combat covered in Strategic Operations.

Units equipped with Stealth Armor can use the Angel ECM in place of the Guardian ECM for the same effect, using the same rules.

# ARMOR

Several new varieties of armor have entered prototype stages over the past several decades, intended to enhance the defensive capabilities of all

types of battlefield units. Most, however, lack the comprehensive coverage offered by today's armor.

## FERRO-LAMELLOR ARMOR

**R&D Start Date:** 3066 (Clan Snow Raven)

**Prototype Design and Production:** 3070 (Clan Snow Raven)

Ferro-Lamellor Armor is an enhanced hybrid of ferro-fibrous armor and WarShip-grade Lamellor armor developed by the Clans for use on smaller

battlefield units such as BattleMechs, Combat Vehicles and fighters. Bulkier than standard Clan ferro-fibrous, this armor demonstrates enhanced energy-reflective capability and improved resilience against kinetic damage.

INTRODUCTION

ADVANCED  
GROUND MOVEMENT

ADVANCED  
COMBAT

ADVANCED  
BUILDINGS

ADVANCED  
SUPPORT  
VEHICLES

GENERAL  
RULES

ADVANCED  
SUPPORT VEHICLE  
CONSTRUCTION

ADVANCED  
WEAPONS  
AND EQUIPMENT

INDEX

RECORD SHEETS

## FERRO-LAMELLOR ARMOR

**Rules Level:** Experimental

**Available To:** BM, IM, CV, SV, AF, CF

**Tech Base (Ratings):** Clan (F/X-X-F)

**Game Rules:** A location protected by Ferro-Lamellor Armor reduces all damage by 1 point for every 5 points (or fraction thereof) delivered per hit (to a minimum of 0 points of damage per hit). Excess damage will affect internal structure or structural integrity per normal rules for the location's structure type. Weapons reduced to zero damage effects by Ferro-Lamellor Armor (such as LB-X cluster munitions), may not inflict pilot injury in the event of a cockpit-location hit, nor may they deliver a penetrating or "floating" critical from special hit location rolls. However, against Combat and Support Vehicles, such weapons *may* inflict Motive System damage effects normally (because such units feature more exposed movement mechanisms).

In addition, Ferro-Lamellor Armor negates the bonus armor-penetrating effects of Armor-Piercing Ammo (see p. 140, *TW*), Tandem-Charge Missiles (see p. 372) and 'Mech Tasers (see p. 345). If these weapons are fired against a location protected by Ferro-Lamellor, they deliver their standard damage to the armor only (Armor-Piercing Ammo hits as a standard AC round; Tandem-Charge Missiles hit as standard SRMs; 'Mech Tasers inflict only 1 point of armor damage).

## HARDENED ARMOR

**R&D Start Date:** 3045 (Federated Commonwealth), 3057 (Clan Ghost Bear)

**Prototype Design and Production:** 3047 (Federated Commonwealth), 3061 (Clan Ghost Bear)

Hardened Armor uses thicker, overlapping plates to enhance a unit's protection at the cost of flexibility. Though hardly a novel concept, production-quality Hardened Armor that consistently enhances protection and minimizes its negative effect on unit mobility remains an elusive goal for most Inner Sphere manufacturers.

## LASER REFLECTIVE (REFLEC/GLAZED) ARMOR

**R&D Start Date:** 3055 (Federated Commonwealth), 3059 (Clan Jade Falcon)

**Prototype Design and Production:** 3058 (Lyran Alliance), 3061 (Clan Jade Falcon)

Workers at Coventry Metal Works accidentally "discovered" a potentially effective form of laser-reflective armor (also known as glazed or "reflec" armor) while working on a batch of ferro-fibrous armor. The resulting high-gloss alloy sharply reduced the effects of laser and flamer fire, but initially

proved over-sensitive to the localized subsurface heating effects of particle cannon fire. Later prototypes eventually worked this out, but little headway has been made against the armor's brittleness, which scarcely protects against specialized armor-defeating munitions and shatters easily in the face of collisions, physical attacks, and other broad-surface damage such as artillery blasts.

**Armor:** The Armor Table below shows the number of points each Advanced Armor type provides per ton installed on the unit, as well as the required slots of internal space and any relevant construction notes. A listing of NA under a unit type's Space slot indicates that such units may not employ the listed Advanced Armor type. Support Vehicles may mount any of these armor types, but must have the Armored Chassis modification to do so (in which case, compute the armor's per-point weight in kilograms by dividing 1,000 by the number of armor points provided per ton); these advanced armors all have a BAR value of 10.

Unless otherwise noted, the armor types presented here remain active and are not affected by pilot injury or engine shutdown. Critical hits to any armor slots have no effect and must be rerolled unless the armor's rules state otherwise.

Finally, of the Advanced Armor types described here, only Modular Armor may be pod-mounted. All other armor types (except for Hardened Armor) are available to units using modular (Omni) technologies, but must be incorporated into the unit's base configuration unless the designer is also using the optional Patchwork Armor design option (see p. 377). Hardened Armor is compatible only with standard, non-Omni units.

## ADVANCED ARMOR TABLE

Advanced Armor Type	Points per Ton	Space						Construction Notes
		BM	IM	CV	SV*	CF	AF	
Ferro-Lamellor	14	12	12	1	1	2	2	Fighter Slots: 1 (per wing)
Hardened	8	0	0	1	NA	NA	NA	May not be carried by VTOL, WiGE, or Hover Combat Vehicles
Laser-Reflective (IS)	16	10	10	1	1	2	2	Fighter Slots: 1 (per wing)
Laser-Reflective (Clan)	16	5	5	1	1	1	1	Fighter Slots: 1 (aft)
Modular	10	1	1	1	1	1	1	1 slot per ton; May not be mounted on Head or Rotor locations
Reactive (IS)	16	14	14	2	2	3	3	Fighter Slots: 1 (per wing), 1 (aft)
Reactive (Clan)	16	7	7	1	1	1	1	Fighter Slots: 1 (aft)
Vehicular Stealth	16	NA	NA	2	2	2	2	ECM Required; Fighter Slots: 1 (per wing); Generates 10 heat**

\*Support Vehicles must have the Armored Chassis Mod and a Minimum Chassis Tech rating of D to install Advanced Armor.

\*\*Heat sinks required to offset heat for non heat-tracking units (Vehicles and Conventional Fighters)

## HARDENED ARMOR

**Rules Level:** Experimental

**Available To:** BM, IM, CV

**Tech Base (Ratings):** Both (D/X-X-F)

**Game Rules:** Each point of Hardened Armor can sustain two points of damage. To reflect this, when marking damage off on a location protected by this armor type, draw a single slash through the armor bubble for the first point of damage sustained, and a second slash, making an "X" (or block the armor bubble out entirely) after the second point (at which point any remaining damage affects the internal structure normally, unless any special rules apply).

Penetrating critical hit checks (including "floating" critical hits) against a unit protected by Hardened Armor (such as those caused by rolling a 2 on the Hit Location Table, or during a successful Swarm Attack) suffer a -2 modifier to all rolls on the Determining Critical Hits Table (including Vehicle Critical Hits Tables). If the attack did not strike a location or facing protected by Hardened Armor, this critical hit modifier does not apply.

In addition, Hardened Armor negates the bonus armor-penetrating effects of Armor-Piercing Ammo (see p. 140, *TW*), Tandem-Charge Missiles (see p. 372) and Tasers (see p. 345). If these weapons are fired against a location protected by Hardened Armor, their damage is not reduced as above, and so they deliver their damage as if they were standard weapons hitting standard armor (Armor-Piercing Ammo hits as a standard AC round; Tandem-Charge Missiles hit as standard SRMs; Mech Tasers inflict only 1 point of armor damage).

Units using Hardened Armor suffer noticeable mobility impairment that affects piloting and speed. To reflect this, Mech units that carry Hardened Armor suffer a +1 Piloting Skill target modifier and -1 Running MP. Combat Vehicles using Hardened Armor suffer a +1 Driving Skill modifier, but no loss in MP.

## LASER REFLECTIVE (REFLEC/GLAZED) ARMOR

**Rules Level:** Experimental

**Available To:** BM, IM, CV, SV, AF, CF

**Tech Base (Ratings):** Inner Sphere (E/X-X-F), Clan (F/X-X-F)

**Game Rules:** Laser Reflective Armor reduces all damage and heat effects from flamers, lasers, PPCs, plasma weapons and energy-based infantry weapons by half (rounded down, to a minimum of 1 point of damage and/or heat; infantry lasers halve their total damage before resolving hit locations normally).

Because the armor is more brittle than usual, however, damage from falls, physical attacks, and moving through building walls is doubled against locations protected by it. In addition, damage from area effect weapons (such as artillery) is doubled against locations protected by Laser Reflective Armor.

For aerospace units, damage to a location protected by Laser Reflective Armor is also doubled for a failed Control Roll that would normally cause damage to that location involving any of the following events: entering a space/atmosphere interface hex (see p. 78, *TW*); launching and recovering (see p. 86, *TW*); landing and take-off (see pp. 87-88, *TW*) and ramming attacks (see p. 241, *TW*). In addition, damage from area effect weapons (such as artillery) is doubled against locations protected by Laser Reflective Armor.

Also, armor-piercing weapons such as Armor-Piercing Ammo (see p. 140, *TW*), Tandem-Charge Missiles (see p. 372) and Tasers (see p. 345) receive a +2 modifier on their armor-piercing effects rolls (Critical Hit checks for AP Ammo and Tandem-Charge Missiles; Taser Effects for Mech and Battle Armor Tasers) for any successful attack against a location protected by Laser Reflective Armor. Against all other weapon types, Laser Reflective Armor behaves normally.

Excess damage beyond the armor's capacity affects internal structure or structural integrity per the normal rules for the location's structure type.

## MODULAR ARMOR

**R&D Start Date:** 3070 (ComStar), 3073 (Clan Wolf-in-Exile)

**Prototype Design and Production:** 3072 (ComStar), 3074 (Clan Wolf-in-Exile)

An outgrowth of research into hardened armor, modular armor emerged when ComStar scientists reached a compromise plan in which additional armor plates and panels were affixed to a unit's underlying frame, more like a weapon mount than as standard armor. These add-on panels and reinforce-

ments effectively created mini-shields that offered enhanced protection, at the expense of flexibility and weapon space. Armed with ComStar's data, the Exiled Wolves quickly mimicked this idea (and the allies even reportedly shared the specs with the Jade Falcons during a recent summit), but neither the Clans nor the Inner Sphere have yet begun full-scale production of modular armor.

## MODULAR ARMOR

**Rules Level:** Experimental

**Available To:** BM, IM, CV, SV, AF, CF

**Tech Base (Ratings):** Both (D/X-X-F)

**Game Rules:** When a location containing a slot of Modular Armor is hit, the damage is subtracted from the Modular Armor capacity first. If a slot of Modular Armor is hit (for example, through a penetrating or floating critical hit, or a Weapon critical on vehicles that randomly rolls up a Modular Armor slot), all remaining points for that slot (if any) are destroyed. Modular Armor slots that are already depleted are considered to be destroyed items.

Because Modular Armor is bulky and its installation exceeds the unit's normal design parameters, units using Modular Armor suffer a +1 modifier to all Piloting Skill target numbers and subtract 1 Walk or Cruise MP, recalculating the unit's Running/Flank MP normally. Fighters apply the +1 modifier to all Control Roll target numbers, as well as subtracting 1 Safe Thrust MP (recalculating Maximum Thrust) when operating in an atmospheric hex. Jump-capable units also subtract 1 Jumping MP. These penalties do not accumulate if the unit carries more than one slot of Modular Armor, but they all apply as long as even 1 point of Modular Armor remains on the unit. Once all points of Modular Armor a unit carries have been destroyed, the mobility and Piloting effects they produce are eliminated.

Modular Armor cannot be "ejected" in gameplay.

INTRODUCTION

ADVANCED  
GROUND MOVEMENT

ADVANCED  
COMBAT

ADVANCED  
BUILDINGS

ADVANCED  
SUPPORT  
VEHICLES

GENERAL  
RULES

ADVANCED  
SUPPORT VEHICLE  
CONSTRUCTION

ADVANCED  
WEAPONS  
AND EQUIPMENT

INDEX

RECORD SHEETS

## REACTIVE (BLAZER) ARMOR

**R&D Start Date:** 3058 (Draconis Combine), 3061 (Clan Ghost Bear)

**Prototype Design and Production:** 3063 (Draconis Combine), 3065 (Clan Ghost Bear)

An anti-ballistic variant of ferro-fibrous armor, reactive armor (also known as Blazer armor) uses a series of micro-explosive charges to reduce all damage from shaped-charge-type weapons such as missiles, mortars

and artillery weapons. The resulting armor also boasted anti-armor-piercing capabilities, negating some of the newer weapons being developed even then. Unfortunately, reactive armor's inability to reduce the effects of other weapons fire or physical damage—coupled with the occasional hazard of runaway explosions caused by seemingly minor hits—has prevented this armor from reaching full-scale production.

## REACTIVE (BLAZER) ARMOR

**Rules Level:** Experimental

**Available To:** BM, IM, CV, SV, AF, CF

**Tech Base (Ratings):** Inner Sphere (E/X-X-F), Clan (F/X-X-F)

**Game Rules:** Reactive Armor reduces all damage from explosive-type weapons such as missiles, mortars and artillery weapons by half (rounded down, to a minimum of 1 point per hit). Physical attacks, as well as attacks using energy weapons, autocannons, Gauss weapons or other weapons deliver their normal damage and effects to the target, but any weapons that rely on an armor-piercing effect, such as Armor-Piercing Ammo (see p. 140, *TW*), Tandem-Charge Missiles (see p. 372) or Tasers (see p. 345) lose any special armor-penetrating abilities if they strike a location protected by Reactive Armor. Excess damage beyond the armor's capacity affects internal structure or structural integrity per the normal rules for the location's structure type.

In addition to the above rules, any penetrating or "floating" critical hits to a Reactive Armor critical slot not only roll the critical hit again as usual, but also require a second 2D6 roll. (Against a non-Mech unit, this occurs any time the unit suffers a critical hit of any kind to a location still protected by Reactive Armor.) If this roll yields a 2, all remaining armor in the location (including front and back in the event of torso hits) is destroyed and the internal structure in that location suffers an additional 1 point of damage (with additional critical hit effects checked as normal).

## VEHICLE STEALTH ARMOR

**R&D Start Date:** 3065 (Capellan Confederation)

**Prototype Design and Production:** 3067 (Capellan Confederation)

Shortly before the start of the Word of Blake Jihad, Capellan engineers began to adapt their groundbreaking stealth armor for use on Combat

Vehicles and aerospace forces as well as BattleMechs. The onset of the Jihad and the predations of the Federated Suns and the Word of Blake have disrupted full-scale production of this armor.

## VEHICLE STEALTH ARMOR

**Rules Level:** Experimental

**Available To:** CV, SV, AF, CF

**Tech Base (Ratings):** Inner Sphere (E/X-X-F)

**Game Rules:** Finally adapted for use in vehicles and fighters, Vehicle Stealth Armor offers the same capabilities as BattleMech Stealth Armor, with the same requirements and drawbacks (see p. 142, *TW*), including the need for a functioning ECM suite (of any type) and the heat generation for operating the system. Vehicles and conventional fighters do not require fusion engines or power amplifiers to mount Vehicle Stealth Armor, but do require heat sinks to contend with the heat costs of using the system.

Aerospace fighters with Vehicle Stealth Armor do not receive stealth benefits when operating above the space/atmosphere interface on the space map if they expend any Thrust Points during the turn. When landed, operating in atmosphere, or when in operating in space without expending Thrust, the range modifiers to hit an aerospace unit equipped with active vehicular stealth armor apply as they do for ground unit (adding a +1 modifier at medium range, and +2 at long or extreme range).

**Armored Components:** Armored components weigh an additional 0.5 tons (to a minimum of 0.5 tons) for every slot they occupy on a standard BattleMech. For example, an Inner Sphere light engine (which occupies 10 critical slots in all) would add 5 tons to its total weight if installed as an armored component (10 slots x 0.5 tons per slot = 5 tons). The only exception is the cockpit location, which adds 1 ton of armor to the cockpit weight.

Any component on a unit's Critical Hit Table can be armored except for ammunition bins, CASE and other items that have a "roll again" effect (such as Ferro-Fibrous Armor slots).

**Armored Motive Systems:** Armored Motive Systems are available only to Combat and Support Vehicles that have a Tracked, Wheeled, Hover, Hydrofoil, Naval (including submarine), or WiGE motive system. VTOLs, Airships, Rail vehicles, Satellites, and other vehicle types may not install Armored Motive Systems. Clan-made Armored Motive Systems take up 10 percent of the vehicle's total weight, while Inner Sphere Armored Motive Systems take up 15 percent of the vehicle's total weight. Neither system occupies weapon space.

**Artemis V Fire-Control System:** As with the Artemis IV fire control system, the Artemis V must be incorporated on all of an individual unit's standard SRM or LRM launchers (or their Torpedo-based equivalents). Artemis V is incompatible with Artemis IV, so any unit designed to have Artemis V cannot also carry Artemis IV (and vice versa).

# ARMORED COMPONENTS

**R&D Start Date:** 3059 (Free Worlds League), 3060 (Clan Diamond Shark)

**Prototype Design and Production:** 3061 (Free Worlds League),  
3061 (Clan Diamond Shark)

Though battlefield systems are already built ruggedly enough for the stresses of modern combat, extensive testing with alternative compart-

mentalizing techniques has enabled engineers to further protect most of a 'Mech's internal components against damage. Cost and weight issues, however, have prevented widespread production of this technology, as well as its expansion into non-'Mech fields.

## ARMORED COMPONENTS

**Rules Level:** Experimental

**Available To:** BM, IM

**Tech Base (Ratings):** Both (E/X-X-F)

**Game Rules:** Each critical slot of an armored component can suffer one critical hit with no effect (a second critical hit to the same slot, however, delivers the same effects as a hit against a standard component). Armored components receive this benefit over all of the component's slots.

Except for ammunition bins, explosive components (such as Gauss rifles) may be installed as armored components, and will explode only upon the second critical hit to a given slot. If an armored component explodes in a location protected by CASE, the CASE system will resolve the effects as per its normal rules.

To indicate if a component is armored, circle the number before each of the critical slots the component takes up. When a slot suffers its first critical hit, draw a slash through the circle for that slot of the armored component. Upon a second hit to the same critical slot, draw a line through the item itself to indicate that it has been damaged as normal.

Armored shoulder and hip actuators that have not received a first critical hit also protect a 'Mech from a Limb Blown Off result on the Determining Critical Hits Table. In such a case, the appropriate shoulder or hip slot is treated as though it suffers its first critical hit, and will be destroyed on any subsequent critical hits to its location (a subsequent Limb Blown Off result also affects the unit as normal if an armored shoulder or hip has already suffered its first critical hit). No component armor can prevent a Blown Off result from happening to a 'Mech's head.

# ARMORED MOTIVE SYSTEM

**R&D Start Date:** 3054 (Clan Hell's Horses), 3069 (Free Worlds League)

**Prototype Design and Production:** 3057 (Clan Hell's Horses),  
3071 (Free Worlds League)

As part of a far more ambitious plan to enhance the durability and flexibility of their conventional forces (the same plan that attempted to revisit the Kanga jump tank concept which resulted in the Hephaestus hover tank),

Clan Hell's Horses' scientists explored new techniques in reinforcing and protecting the vulnerable motive systems for their ground-based combat vehicles. Though weighty, the concept was at least partially successful. A shift in Horses' priorities, however, prevented widespread development. Rumors of this breakthrough, however, intrigued engineers at IrTech, who recently managed to duplicate the Clan's techniques using Spheroid technology.

## ARMORED MOTIVE SYSTEM

**Rules Level:** Experimental

**Available To:** CV, SV

**Tech Base (Ratings):** Inner Sphere (E/X-X-F), Clan (F/X-X-F)

**Game Rules:** Armored Motive Systems apply an additional -2 modifier to any rolls made on the Motive System Damage Table for a vehicle equipped with this system. A result of 2 or less reflects no effect to the vehicle's motive systems.

# ARTEMIS V FIRE-CONTROL SYSTEM

**R&D Start Date:** 3058 (Clan Goliath Scorpion)

**Prototype Design and Production:** 3061 (Clan Goliath Scorpion)

A Clan-made enhancement to the Artemis IV fire control system, the Artemis V improves the accuracy of standard LRM and SRM launchers better than ever, but at a cost in bulk and weight, and remains susceptible to hostile ECM suites including the Guardian, Angel and Watchdog.

## ARTEMIS V FIRE-CONTROL SYSTEM

**Rules Level:** Experimental

**Available To:** BM, IM, CV, SV, AF, CF, SC, JS, DS, SS, WS, MS

**Tech Base (Ratings):** Clan (F/X-X-F)

**Game Rules:** Missile launchers using a functional Artemis V system apply a -1 to-hit modifier to the attack roll, and add +3 to the Cluster Hits Table (to a maximum modified result of 12). Aerospace units using Artemis V-enhanced launchers receive the same to-hit modifier only if all the launchers in a firing bay employ Artemis V, but determine the standard Attack Value as equal to a roll result of 10 on the appropriate-sized launcher on the Cluster Hits Table, delivered per the standard rules (as a standard-scale hit, in strictly aerospace combat, as with other missile systems, or as Clusters appropriate to the launcher type and size, when fired against ground units). Appropriate Point Defense rules may affect this damage value as normal.

INTRODUCTION

ADVANCED  
GROUND MOVEMENT

ADVANCED  
COMBAT

ADVANCED  
BUILDINGS

ADVANCED  
SUPPORT  
VEHICLES

GENERAL  
RULES

ADVANCED  
SUPPORT VEHICLE  
CONSTRUCTION

ADVANCED  
WEAPONS  
AND EQUIPMENT

INDEX

RECORD SHEETS

# ARTILLERY

Artillery weapons are a common and effective—but not always reliable—source of fire support in the major ground engagements of the BattleTech universe. Unless otherwise noted, the artillery weapons described here follow the same basic gameplay rules as presented on p. 179 for Artillery

Weapons, and may not be fired by any applicable aerospace units (except Arrow IV; see p. 180) unless the units is first landed or its special munitions (see p. 359) rules permit otherwise.

## ARROW IV ARTILLERY MISSILE

**Introduced:** 2600 (Terran Hegemony)

**Extinct:** 2830 (Inner Sphere)

**Recovered:** 3044 (Capellan Confederation)

Loosely based on short-range ballistic missile technology, the Arrow IV system is a sophisticated, missile-based artillery weapon that debuted

during the Age of War. Lost after the last of the Terran Hegemony's major producers were destroyed in the wake of the Star League's collapse, the technology was revived by Capellan engineers—armed with the knowledge of the Helm Memory Core—from the handful of mothballed samples they unearthed in the mid-3040s.

## ARROW IV ARTILLERY MISSILE

**Rules Level:** Advanced

**Available To:** BM, IM, CV, SV, AF, CF, SC, DS, MS

**Tech Base (Ratings):** Both (E/E-F-E)

**Game Rules:** The Arrow IV Artillery Missile launcher uses the standard rules for Indirect Artillery (see p. 179) and Direct-Fire Artillery (see p. 185), as well as Counter-Battery Fire (see p. 186), but can also employ specialized homing rounds that work in conjunction with friendly Target Acquisition Gear (TAG) systems. The rules for Arrow IV Homing Missile attacks are covered on p. 354.

## CONVENTIONAL ARTILLERY (THUMPER/SNIPER/LONG TOM)

**Introduced:** Pre-spaceflight

Often referred to as “tube artillery” (to differentiate them from missile artillery weapons like the Arrow IV), the conventional artillery pieces of the Succession Wars—the Thumper, Sniper and Long Tom—remain the

standard by which most similar weapons are measured. Often employing unguided, unpowered rounds, conventional artillery relies on technology that predates humankind's first steps among the stars.

## CONVENTIONAL ARTILLERY (THUMPER/SNIPER/LONG TOM)

**Rules Level:** Advanced

**Available To:** BM, IM, CV, SV, SC, DS, MS

**Tech Base (Ratings):** Both (B/C-C-C)

**Game Rules:** Thumper, Sniper and Long Tom artillery weapons use the standard rules for Indirect Artillery (see p. 179) and Direct-Fire Artillery (see p. 185), as well as Counter-Battery Fire (see p. 186), and may use a broad range of alternate ammunition loads, including standard, Smoke, Anti-Personnel, Incendiary and Thunder/FASCAM rounds.

## CRUISE MISSILE ARTILLERY

**R&D Start Date:** 3060 (Federated Commonwealth)

**Prototype Design and Production:** 3065 (Federated Suns)

Though technically a proven, pre-spaceflight concept, cruise missiles faded from the military stage when spacecraft—and capital-scale missile

technologies—became prevalent. The modern tactical cruise missile artillery platforms being developed are effectively heavily modified versions of the Arrow IV launch system, but boast much greater range and damage potential at a significant loss in accuracy.

**Artillery:** All of the Artillery Weapons presented here may be installed on their respective Available Unit types in accordance with the unit's standard construction rules. Ammunition for Artillery Weapons must always be purchased in 1-ton lots.

**Artillery Cannons:** All of the Artillery Cannons presented here may be installed on their respective Available Unit types in accordance with the unit's standard construction rules (for aerospace units, Artillery Cannons are classified as autocannons and may be mounted as part of an autocannon bay). Ammunition for Artillery Cannons must always be purchased in 1-ton lots. The weight of any Artillery Cannons mounted on a unit does not impact the weight of any Targeting Computer equipment mounted on the same unit.

**Autocannon:** All versions of the Hyper-Velocity Autocannon, ProtoMech Autocannon and Clan Rotary Autocannon may be installed per the appropriate unit's standard construction rules for mounting weapons.

ProtoMechs can only mount the ProtoMech AC in a Main Gun mount.

Ammunition for most of the advanced autocannon types featured here may only be installed in full-ton lots. ProtoMech ACs, which are intended for ProtoMech use, install ammunition on a per-shot basis; each shot of ProtoMech AC ammunition—in kilograms—may be found by dividing the number 1,000 by the weapon's number of shots per ton. Unless stated otherwise in the weapon's individual rules, these weapons may only use their own standard ammunition types.

## CRUISE MISSILE ARTILLERY

**Rules Level:** Experimental

**Available To:** CV, SV, SC, DS, MS

**Tech Base (Ratings):** Inner Sphere (E/X-X-F)

**Game Rules:** In game play, Cruise Missile Artillery functions just like artillery systems using standard munitions (see p. 353), with the following exceptions:

- Cruise Missiles may not deliver any Direct-Fire Artillery attacks (see p. 185).
- Cruise Missiles use a different Indirect Flight Time than conventional artillery or Arrow missiles, as indicated in the Indirect Artillery Flight Times Table (see p. 181).
- Cruise Missile damage radiates more widely from the impact hex, as indicated in the Artillery Ordnance Table (see p. 184).

## ARTILLERY CANNONS

**R&D Start Date:** 3000 (Lyran Commonwealth), 3030 (Clan Wolf)

**Prototype Design and Production:** 3012 (Lyran Commonwealth), 3032 (Clan Wolf)

An alternative approach to artillery weapons, artillery cannons are small-

er, snub-nosed versions of the common tube artillery pieces. While useful for area-effect attacks, artillery cannons suffer from a sharp reduction in range compared to their standard cousins. Though well past the prototype stage, artillery cannons have yet to begin consistent, full-scale production.

## ARTILLERY CANNONS

**Rules Level:** Experimental

**Available To:** BM, IM, CV, SV, AF, CF, SC, JS, DS, SS, WS, MS

**Tech Base (Ratings):** Both (B/X-F-E)

**Game Rules:** Artillery Cannons are classified as ballistic weapons, rather than artillery weapons, and may not be used to deliver Indirect Artillery attacks. In ground combat, Artillery Cannon attacks are resolved in the same fashion as indirect LRM fire against a target unit (see pp. 111-112, *TW*), but deliver damage to both the target's hex and all adjacent hexes in accordance with the standard rules for artillery damage. Missed shots by Artillery Cannons scatter per standard Artillery rules (see p. 182), but when rolling for scatter distance (from the intended target), divide the die roll result in half (rounding up) to determine the number of hexes the missed shot will scatter.

Aerospace units employing Artillery Cannons use them as autocannons, and cannot deliver damage effects into adjacent hexes, regardless of any special munitions used.

Artillery Cannons may use the same ordnance types available to a conventional artillery weapon of similar class (for example, a Thumper Artillery Cannon can use the same ammo types available to a standard Thumper artillery piece). As area-effect weapons, Artillery Cannons cannot benefit from the use of a Targeting Computer.

## AUTOCANNONS

Spurred on by Clan innovations in weapon technology, designers across the Inner Sphere have expanded their efforts to enhance autocannons.

Inspired by the rediscovered LB-X and Ultra series, several new autocannon variations have entered production stages over the past twenty years.

### HYPER-VELOCITY AUTOCANNON (HVAC)

**R&D Start Date:** 3055 (Capellan Confederation)

**Prototype Design and Production:** 3059 (Capellan Confederation)

The Hyper-Velocity Autocannon (HVAC) fires a special gelled shell propellant. This results in a round that travels much faster and produces accurate

damage at greater ranges than standard autocannons. The special munitions, however, require harder components than those in standard ACs, resulting in a larger and heavier autocannon. The lingering danger of catastrophic misfeed has so far prevented this weapon system from entering full-scale production.

### HYPER-VELOCITY AUTOCANNON (HVAC)

**Rules Level:** Experimental

**Available To:** BM, IM, CV, SV, AF, CF, SC, JS, DS, SS, WS, MS

**Tech Base (Ratings):** Inner Sphere (D/X-X-F)

**Game Rules:** HVACs function exactly like standard ACs in combat, with the following exceptions:

- On a to-hit roll result of 2, the chambered round's propellant ignites within the barrel, inflicting internal explosion damage equal to that of a single round from the HVAC and destroying all the HVAC's critical slots (in addition to any other critical hits rolled up from the explosion).
- If a HVAC is fired in any type of atmosphere, the hex behind the firing unit (and opposite the firing direction, if applicable) is filled with heavy smoke (see p. 47). This smoke fills 2 elevations above the level of the firing unit's hex equal to the unit's height (in the case of buildings and Mobile Structures, the top elevation is equal to the height of the level where the weapon is mounted); the elevation is determined by the level of the underlying terrain of the attacker's hex, not the hex filled with smoke. If either elevation is occupied by a hill, building, Large Vehicle, Mobile Structure or DropShip, both elevations of smoke occupies the firing unit's hex. For a DropShip, Mobile Structure, Large Naval Vessel or building, the smoke fills the first hex along the LOS of the attack instead of behind the unit. The smoke dissipates at the start of the End Phase of the turn after the weapon was fired; if using Wind Conditions (see p. 57), the smoke will drift during the End Phase in which it was fired, as appropriate.

INTRODUCTION

ADVANCED  
GROUND MOVEMENT

ADVANCED  
COMBAT

ADVANCED  
BUILDINGS

ADVANCED  
SUPPORT  
VEHICLES

GENERAL  
RULES

ADVANCED  
SUPPORT VEHICLE  
CONSTRUCTION

ADVANCED  
WEAPONS  
AND EQUIPMENT

INDEX

RECORD SHEETS

## PROTOMECH AUTOCANNONS (PROTO-AC)

**Introduced:** 3073 (Clan Blood Spirit)

In an effort to expand on the weapons opportunities for ProtoMechs, Blood Spirit scientists evidently dusted off some obsolete early Clan efforts to miniaturize standard autocannons. Though most such weapons vanished by the time of the Clan invasion, enough mothballed samples and specs evi-

dently existed to spur the development of a new series aimed at ProtoMech use (but usable by other heavy combat units as well), likely inspired by tales of the new Inner Sphere Light autocannon series. As yet, the Spirits have not reportedly placed their so-called ProtoMech ACs into full-scale production, preferring to be sure of the snub-nosed weapons' reliability in live fire tests.

## PROTOMECH AUTOCANNONS (PROTO-AC)

**Rules Level:** Advanced

**Available To:** BM, IM, PM, CV, SV, AF, CF, SC, JS, DS, SS, WS, MS

**Tech Base (Ratings):** Clan (F/X-X-F)

**Game Rules:** ProtoMech Autocannons use the same rules as standard autocannons. When mounted on ProtoMechs, ProtoMech ACs are treated in the same manner as ballistic weapons on vehicles, and so do not generate heat.

## CLAN ROTARY AUTOCANNON (RAC)

**R&D Start Date:** 3069 (Clan Diamond Shark)

**Prototype Design and Production:** 3073 (Clan Diamond Shark)

Clan Diamond Shark scientists began work on their own analog to the rotary autocannon in the late 3060s using lighter Clan technologies. The resulting weapon system promises to offer the Clans a weapon similar to the Inner Sphere rotary AC in many ways, yet far more effective.

## CLAN ROTARY AUTOCANNON (RAC)

**Rules Level:** Experimental

**Available To:** BM, IM, CV, SV, AF, CF, SC, JS, DS, SS, WS, MS

**Tech Base (Ratings):** Clan (F/X-X-F)

**Game Rules:** The Clan Rotary Autocannon operates as a rapid-fire weapon (see p. 114, *TW*) and follows the rules for rotary autocannons (see p. 140, *TW*).

# BATTLE ARMOR MECHANICAL JUMP BOOSTER

**R&D Start Date:** 3065 (Lyran Alliance)

**Prototype Design and Production:** 3070 (Lyran Alliance)

Designed to duplicate the experimental BattleMech Mechanical Jump Booster system on a smaller scale, Battle Armor Mechanical Jump Boosters primarily promise to eliminate a jump-capable battlesuit's dependence on chemical fuels. The original concept for these boosters limited them to quad-

ruped suits. However, by the time the system reached prototype stage, a more innovative piston design made them usable by bipedal battle armor as well.

Though the lack of a BattleMech's long stride and the extended jump jet acceleration phase renders Battle Armor Mechanical Jump Boosters sharply limited in range, the 30-meter leaps made possible by these jump boosters do offer a useful edge in ground speed.

**Battle Armor Mechanical Jump Booster:** A suit of battle armor may mount only one Mechanical Jump Booster system. The boosters are limited to 1 Jump MP, but can receive added Jump bonus points through the use of a partial wing (though no such benefit applies for the use of Battle Armor Jump Boosters). A suit with Battle Armor Mechanical Jump Boosters also gains 1 additional Ground MP, even if this bonus exceeds the unit's normal maximum Ground MP limit.

Battle Armor Mechanical Jump Boosters are incompatible with Battle Armor Myomer Boosters.

**Battle Armor Myomer Booster:** A suit of battle armor may mount only one Battle Armor Myomer Booster system. The boosters add 1 Ground MP to Assault and Heavy suits, and 2 Ground MPs to Medium, Light and PA(L) suits, even if this booster-provided bonus exceeds the unit's normal maximum Ground MP limit. Battlesuits equipped with Myomer Boosters may not mount Stealth or Mimetic Armor.

Battle Armor Myomer Boosters are incompatible with Battle Armor Mechanical Jump Boosters.

**Battle Armor Detachable Weapon Pack (DWP):** Only Medium, Heavy or Assault battle armor can install a Battle Armor DWP, and may not install this item if the suit's resulting Ground MP will fall below 0. Suits reduced to a Ground MP of exactly 0 for mounting a DWP receive a maximum Ground MP of 1 while carrying any DWPs. Multiple DWPs have no additional effect on a unit's ground MP.

Each DWP occupies 1 slot in the suit's body, and may carry only one weapon (and its ammunition). Such weapons may include any battle armor weapon except for missile launchers (including LRMs, SRMs, Advanced SRMs, Rocket Launchers and Narcs).

While mounted in a DWP, the weapon and its ammunition are calculated at only 75 percent of their original weight (rounded up to the nearest 5 kilograms), and that weight is used when computing the suit's total weight during construction. (Note that a suit still may not exceed its designed maximum weight in this fashion; it simply treats a DWP-mounted weapon and its ammunition as a lighter weapon during construction.) Because the weapon is installed semi-externally, the normal slot size of a DWP-mounted weapon is not counted against the suit's slot capacity.

## BATTLE ARMOR MECHANICAL JUMP BOOSTER

**Rules Level:** Experimental

**Available To:** BA

**Tech Base (Ratings):** Inner Sphere (E/ X-X-F)

**Game Rules:** Battle Armor Jump Boosters act like standard jump jets, with the following exceptions:

- Because the boosters cannot be steered in mid-flight, Battle Armor using this system cannot use Jump MP and Initiate Anti-'Mech Attacks in the same turn.
- Mechanical Jump Boosters can be used even when submerged (as long as the armor is otherwise capable of underwater operation).
- A single battlesuit may mount standard jump jets and Mechanical Jump Boosters, but cannot use both systems in the same turn. Having one system does not add to the Jumping MP provided by the other, but Battle Armor Mechanical Jump Boosters may also receive the Jumping MP bonus provided by a partial wing (if the suit has one).
- Battle Armor Mechanical Jump Boosters may be used *without* jumping to enhance a suit's standard ground movement. This mode of travel—which replaces the suit's usual stride with a swifter, loping gait more akin to making miniature hops—adds +1 to the suit's Ground MP.

## BATTLE ARMOR MYOMER BOOSTER

**R&D Start Date:** 3066 (Clan Ice Hellion)

**Prototype Design and Production:** 3072 (Clan Ice Hellion)

Initially conceived as a spin-off from failed Ice Hellion efforts to create an enhanced BattleMech MASC system, the battle armor-scaled myomer booster offers to increase the speed and strength of a given battlesuit de-

sign. However, the system's greatest drawback is the tremendous amount of heat generated—which not only makes it impossible to employ such enhanced myomer suits in a stealth role, but requires the installation of bulky cooling systems to avoid parboiling the trooper within.

## BATTLE ARMOR MYOMER BOOSTER

**Rules Level:** Experimental

**Available To:** BA

**Tech Base (Ratings):** Clan (F/X-X-F)

**Game Rules:** Battle Armor Myomer Boosters increase the maximum Ground MP for PA(L), Light- and Medium-weight suits by 2 MP. Heavy- and Assault-weight suits receive a 1-point Ground MP bonus. This movement modifier may take the suit movement beyond its normal upper limit.

Battlesuits equipped with Myomer Boosters generate excessive heat, making them incapable of operating as hidden units and rendering any Stealth or Mimetic Armor ineffective. ECM systems will still affect other electronic systems that pass through the ECM "bubble," but the suits themselves remain visible on sensors due to their heat signature.

All Leg and Swarm Attacks performed by battle armor with Myomer Boosters add 2 points (per active trooper) to the total damage inflicted by a successful assault.

## BATTLE ARMOR DETACHABLE WEAPON PACK (DWP)

**Introduced:** 3072 (Clan Hell's Horses), 3073 (Word of Blake)

Recognizing the need for even heavier weapon loads on battle armor, both the Inner Sphere and the Clans have developed the Detachable Weapon Pack (DWP), though the Hell's Horses first debuted the system on

their new Rock Golem assault battlesuits. Derived from the proven design of detachable missile pack modules seen on classic Elemental armor, these semi-external non-missile mounts enable battlesuits to exceed their normal load maximums, but at a significant cost in mobility.

## BATTLE ARMOR DETACHABLE WEAPON PACK (DWP)

**Rules Level:** Advanced

**Available To:** BA

**Tech Base (Ratings):** Both (E/X-X-F)

**Game Rules:** Each DWP enables a suit to carry a single non-missile weapon and its ammunition semi-externally, so that heavier and larger weapons may be mounted in slight excess of the suit's design. This expanded carrying capacity, however, impairs the suit's movement and renders it incapable of using Jump MP for as long as the battle armor carries even a single DWP. Medium suits using DWPs also suffer a -3 Ground MP penalty, while heavy and assault suits using DWPs suffer a -2 Ground MP penalty. Mechanical Jump Boosters or Myomer Boosters can increase the Ground MP of a suit using DWPs, but may not be used for Jumping movement as long as the DWP is attached.

A battle armor squad can jettison one, some, or all of the DWPs on its component suits during the End Phase of any turn to regain mobility, though doing so sacrifices the weapons mounted in the DWPs. A battle armor unit only regains full mobility from dumping its DWPs if all DWPs from all of the squad's troopers are jettisoned.

INTRODUCTION

ADVANCED  
GROUND MOVEMENT

ADVANCED  
COMBAT

ADVANCED  
BUILDINGS

ADVANCED  
SUPPORT  
VEHICLES

GENERAL  
RULES

ADVANCED  
SUPPORT VEHICLE  
CONSTRUCTION

ADVANCED  
WEAPONS  
AND EQUIPMENT

INDEX

RECORD SHEETS

# BATTLEMECH HARJEL SYSTEM

**R&D Start Date:** 3056 (Diamond Sharks), 3062 (Lyran Alliance),  
**Prototype Design and Production:** 3059 (Diamond Sharks), 3067 (Lyran Alliance)

Inspired by the HarJel hull-sealing system used aboard Clan spacecraft and battle armor, both the Clans and Inner Sphere have developed a variant

for 'Mechs and vehicles. After being "leaked" to certain pro-Clan stables on Solaris, the Inner Sphere gained access to this technology as well, but since both the Spheroid and Clan versions rely on large amounts of actual HarJel to work, this system has yet to see widespread production and remains in the prototype stage.

## BATTLEMECH HARJEL SYSTEM

**Rules Level:** Experimental

**Available To:** BM, IM, CV, SV

**Tech Base (Ratings):** Both (E/X-X-E)

**Game Rules:** When operating underwater (see p. 121, *TW*) or in a vacuum (see *Vacuum*, p. 54) a unit equipped with the HarJel system is not required to check for hull breaches for any location that features a BattleMech HarJel slot *and* has any armor remaining in that location. In addition, the HarJel system provides a -1 modifier to any roll checking for hull breach from extreme depths (see p. 42). Hull breach is still automatic, however, once all armor is destroyed, whether or not the unit mounts a HarJel system in that location. HarJel does not protect any body section that does not have a HarJel slot.

Regardless of the environment in which the unit is operating, a critical hit to a BattleMech HarJel System slot immediately releases its full load of self-hardening sealant, flooding the affected location and disabling all components within it. Treat any weapons or equipment in a location flooded in this fashion as effectively destroyed (though Gauss weapons and other volatile equipment will not explode), but they can still be damaged by subsequent critical hits. Ammunition in a HarJel-flooded section remains explosive and cannot be dumped. Clearing a flooded section and restoring all affected components requires twice as much time as normal.

# BATTLEMECH MELEE WEAPONS

Since the Lyrans began fielding the *Hatchetman* in 3025, BattleMech-scaled melee weapons have carved out a dramatic and permanent niche in the arsenals of many Inner Sphere armies. Production-level triple strength myomer has only fueled the growing number of weapons that seek to improve upon the steadfast hatchet. Nowhere is this more evident than

the arenas of Solaris VII, where deadlier, showier and more creative ways to crush the enemy in close combat have evolved.

**Game Rules (General):** Unless otherwise noted, 'Mechs armed with multiple BattleMech Melee Weapons of any type may only attack with one such weapon during a given Physical Attack Phase.

## CHAIN WHIP

**R&D Start Date:** 3069 (Lyran Alliance)  
**Prototype Design and Production:** 3071 (Word of Blake)

Initially researched as another exotic weapon for the Solaran arenas, myomer-cable "whips" were first tested during the initial Blakist attacks on Solaris VII as a special means of close combat aimed at entangling and

capturing invader units. Though these initial prototypes failed, the so-called chain whip emerged when the Word of Blake forces on Solaris modified the concept with armor-alloy chains for added strength and resilience. Though the damage from a chain whip impact is not terribly impressive, the entangling effect has proven useful for limiting the mobility of opposing 'Mechs.

**BattleMech HarJel System:** BattleMechs and IndustrialMechs may mount a HarJel system in any body location(s) desired, except for the location containing the cockpit. Vehicles may mount HarJel systems in any location(s) desired except the Body and the Rotor.

**BattleMech Melee Weapons:** All of the advanced BattleMech melee weapons described in these rules may be mounted in accordance with all standard 'Mech construction rules, with special construction rules as noted below. Except for the shield (which may only be installed as fixed equipment), OmniMechs may mount all of these weapons as pods or as fixed equipment. A 'Mech can mount only one physical attack weapon per location, unless one of the weapons is a shield or spikes.

**Claws:** Each Claw weighs 1 ton and occupies 1 critical slot for every 15 tons of BattleMech weight (rounded up to the nearest half ton). Claws may only be installed only in the arms of a 'Mech, where it automatically replaces the hand actuator (but still requires both the upper and lower arm actuators). Two Claws, replacing each hand actuator in both arms, may be mounted.

**Flail:** The Flail weighs 5 tons and occupies 4 critical slots. Flails can only be mounted in a 'Mech's arms. The Flail's mount replaces the 'Mech's hand actuator, but still requires the upper and lower actuators.

**Lance:** A Lance weighs 1 ton and occupies 1 critical slot for every 20 tons of 'Mech weight (rounded up to the nearest half ton). Lances may only be mounted in a 'Mech's arms. Installing Lances does not require a hand actuator to be located in the same arm, but arms intended to use Lances must have shoulder, upper and lower arm actuators.

**Mace:** The Mace weighs 1 ton and occupies 1 critical slot for every 10 tons of 'Mech weight (rounded up to the nearest full ton). A Mace can only be mounted in a 'Mech's arm, and then only in an arm that includes a hand actuator.

**Shield:** Shields come in Small, Medium and Large sizes, and may only be mounted in arm locations. Regardless of size, only 1 Shield may be mounted per arm. Shields have no special actuator requirements. Shields are hard-mounted, and so Shield-based movement modifiers apply to the unit at the time of construction.

**Spikes:** Spike clusters weigh half a ton and occupy 1 critical slot; only one cluster may be mounted in a given location. Torso locations cover both front and back arcs.

**Talons:** Talons must be placed in all of the 'Mech's legs, and require 2 critical slots per leg to install. The Talons' total weight is 1 ton per 15 tons (rounded up to nearest whole ton).

**Vibroblades:** 'Mech Vibroblades come in three fixed sizes and otherwise follow the standard rules for mounting swords.

## CHAIN WHIP

**Rules Level:** Experimental

**Available To:** BM, IM

**Tech Base (Ratings):** Inner Sphere (C/X-X-F)

**Game Rules:** Against all unit types, the Chain Whip delivers its attack using the same rules as a BattleMech Sword (see pp. 146-147, *TW*), with the same to-hit modifiers, damage, and basic Physical Attack rules. However, the whip's damage is not modified for the use of Triple-Strength Myomer or the weight of the Attacker, as the heavy chain and its myomer cable lack rigidity. Against 'Mech and ProtoMech units, the whip can perform additional bonus attacks if the hit location result yields a target's arms or legs.

In the case of a leg hit on a 'Mech, the whip-wielding unit may attempt to pull its opponent off balance by making a second (bonus) attack immediately after the successful whip attack occurred (during the same Physical Attack Phase). This bonus attack applies an additional -2 modifier if the whip-wielding unit has active Triple-Strength Myomers *and* the target does not. If successful, the attack delivers no damage, but the defending unit must make a successful Piloting Skill roll at a +3 target modifier to avoid falling.

In the case of an arm hit on a 'Mech (or either the arms or legs of a ProtoMech), the whip-wielding unit may attempt to grapple its opponent instead, preventing either unit from moving the following turn. Once again, this is treated as a bonus attack in the same Physical Attack Phase that applies an additional -2 to-hit modifier if the whip-wielding unit has active Triple-Strength Myomers and the target does not. For every weight class (ProtoMech, Light, Medium, Heavy and so forth) the Attacker outweighs the Defender, a -1 to-hit modifier applies to the grapple attack; if the Defender outweighs the Attacker, a +1 modifier applies for each weight class of difference. If this bonus attack is successful, the Defender is grappled and neither unit may move in the following turn (unless the Attacker chooses to release the Defender by expending any MP in the following Movement Phase). However, while grappled, both the grappling 'Mech and the grappled 'Mech may make weapon and physical attacks normally, using weapons in any location except for the grappling unit's whip arm and the grappled unit's grappled arm. If the grappling unit is attacking the grappled unit (or vice versa), a -2 modifier applies to these attacks. Each turn after making a successful grapple, the grapple roll (but not the initial to-hit roll) must be made to maintain the grapple. If a grapple roll fails, the whip has released (or failed to grapple) the target.

## CLAWS

**Introduced:** 3060 (Lyran Alliance)

These specially modified hand actuators are an on-again, off-again crowd favorite in arenas across the Inner Sphere, prompting numerous redesigns until Solaris Arms of Solaris set the final standard in the early 3060s on their

*Mantis* dueling 'Mech. Intended for raw, armor-rending strength, claws are far less dexterous than standard hand actuators, making them ill-suited to anything but close-quarters combat.

## CLAWS

**Rules Level:** Advanced

**Available To:** BM, IM

**Tech Base (Ratings):** Inner Sphere (B/X-F-E)

**Game Rules:** Claw attacks are resolved per the rules of a standard punching attack (see p. 145, *TW*), but with an additional +1 to-hit modifier due to the Claw's bulk. If successful, the Claw inflicts 1 point of damage for every 7 tons of BattleMech weight (rounded up), modified for any actuator damage and active Triple-Strength Myomer use.

'Mechs with Claws may lift objects as normal, but must make a successful Piloting Skill roll with a +2 target modifier to avoid damaging them. If the object is extremely fragile (such as a human being), an additional +1 modifier applies (at the gamemaster's discretion or mutual player agreement). Claws may not be combined with any other melee weapon in the same arm, but they may be used to grab and wield an improvised club, with an additional +2 to-hit penalty (see pp. 146-147, *TW*). A failed attempt to lift an object effectively destroys it.

## FLAIL

**R&D Start Date:** 3054 (Federated Commonwealth)

**Prototype Design and Production:** 3057 (Federated Commonwealth)

Inspired by the classic and familiar wrecking ball, the BattleMech-scale flail is nothing more than a ball of spiked tungsten alloy attached to a 'Mech

via a short, reinforced myomer tether. Though balanced for swinging, it is still somewhat difficult to use effectively. A missed attack can have grave consequences for the Attacker, as the free-swinging flail can double back on its own user.

## FLAIL

**Rules Level:** Experimental

**Available To:** BM, IM

**Tech Base (Ratings):** Inner Sphere (B/X-X-E)

**Game Rules:** The Flail attacks like a hatchet (see pp. 146-147, *TW*), with an additional +1 to-hit modifier to all attacks. If successful, the Flail delivers 9 points of damage that is not modified by actuator damage or the use of special myomers.

On a Flail attack roll result of 2, the Attacker automatically misses the intended target, and instead strikes its own unit. Such a self-inflicted strike delivers only 5 points of damage, resolved using the Front Hit Location Table. Additionally, the Attacker must make a Piloting Skill roll to avoid falling from being thrown off-balance by the shock of such a critical miss (with all normal Piloting Skill modifiers applied).

INTRODUCTION

ADVANCED  
GROUND MOVEMENT

ADVANCED  
COMBAT

ADVANCED  
BUILDINGS

ADVANCED  
SUPPORT  
VEHICLES

GENERAL  
RULES

ADVANCED  
SUPPORT VEHICLE  
CONSTRUCTION

ADVANCED  
WEAPONS  
AND EQUIPMENT

INDEX

RECORD SHEETS

## LANCE

**R&D Start Date:** 3061 (Lyran Alliance)

**Prototype Design and Production:** 3064 (Lyran Alliance)

More of a BattleMech stiletto than a 31st-century translation of an actual medieval weapon, the BattleMech-scale lance combines armor-piercing capabilities with a lightweight design, but lacks the raw kinetic damage of

most other melee weapons. Though an unpopular weapon overall, due to the sheer finesse required to make it effective, the lance nevertheless enjoyed a small yet devout following in several lower-class leagues on Solaris VII (leading to the slightly enhanced design that debuted just before the Word seized the planet in 3068).

## LANCE

**Rules Level:** Experimental

**Available To:** BM, IM

**Tech Base (Ratings):** Inner Sphere (C/X-X-F)

**Game Rules:** Requiring a direct strike to be effective, the Lance attacks as a hatchet (see pp. 146-147, *TW*) with an additional +2 to-hit modifier, and delivers damage equal to the unit's tonnage divided by 5 (round up). If armor remains in the location after a Lance attack, the Attacker rolls 2D6. On a result of 10 or higher, the strike penetrates the remaining armor and inflicts 1 point of internal damage. A Lance that penetrates armor in this fashion rolls on the Determining Critical Hits Table with a -2 modifier to the roll result. (A successful Lance attack that strikes unarmored internal structure rolls for Determining Critical Hits normally.)

## MACE

**Introduced:** 3061 (Lyran Alliance)

A stylized club designed for close-quarters arena combat, the 'Mech-scale mace first appeared in the stables of Solaris VII as a stylized form of the basic hatchet. As popularity (and the sheer number of visual styles)

grew, Solaran engineers developed a heavier and more distinctive weapon, though it wasn't until the early 3060s that the weapon reached a reliable, production-level standard.

## MACE

**Rules Level:** Advanced

**Available To:** BM, IM

**Tech Base (Ratings):** Inner Sphere (B/X-F-D)

**Game Rules:** The Mace attacks as a Physical Weapon Attack with a +1 to-hit modifier, but may use the Hatchet's To-Hit Location Table (see pp. 146-147, *TW*).

If a Mace attack misses its target, the Attacker must make a Piloting Skill roll with a +2 target modifier to avoid falling.

## SHIELD

**R&D Start Date:** 3065 (Lyran Alliance)

**Prototype Design and Production:** 3067 (Lyran Alliance)

From hastily wielded armor plates to well designed 'Mech additions, shields are a common sight in the lower-class arenas of several game worlds. The most effective versions, of course, were developed on Solaris shortly

before the Jihad (where they had yet to advance beyond the prototype phase before Blakist forces attacked and seized that world). If used well, the 'Mech-scale shield has definite potential in combat, though its bulk can hinder a 'Mech's mobility and combat effectiveness.

## SPIKES

**Introduced:** 3051 (Federated Commonwealth)

Though long used as a popular cosmetic enhancement, providing BattleMechs with a fearsome and barbaric look, it was not until after the demonstrated effectiveness of the hatchet as a 'Mech-scale physical attack weapon that spikes were seriously considered as a potentially viable new

weapon (and passive defense system) for close combat. Through the testing grounds of the Game World, spikes gradually evolved from simple decorative cones to the much more effective protrusions they are today. Despite their proven capability, however, spikes remain a rare sight beyond the arenas.

## TALONS

**Introduced:** 3072 (Jade Falcons)

A curious innovation considering the Clans' disdain for physical combat, the Jade Falcons' talons arose as a kind of "functional cosmetic" similar to the

spikes on Solaris 'Mechs. Spotted only sporadically on customized variants to date (likely serving as battlefield test-beds), they have demonstrated potential in enhancing the effectiveness of kicking and Death from Above attacks.

## SHIELD

**Rules Level:** Experimental

**Available To:** BM, IM

**Tech Base (Ratings):** Inner Sphere (D/X-X-F)

**Game Rules:** All three sizes of BattleMech Shield have a Damage Absorbance (DA) factor, a Damage Capacity (DC) factor, a Shield Bash to-hit modifier and a Mobility Modifier (as indicated in the 'Mech Shield Table below). A shield's DA indicates how effective it is against incoming damage, while its DC indicates if it is still functioning. A shield's Bash modifier indicates the to-hit modifier applied when making a special Shield Bash attack, and its Mobility Modifier indicates the shield's effect on a 'Mech's Walking, Running and Jumping MPs when carrying a shield. A shield with either a DC or DA value of 0 is no longer effective in combat, but continues to impose movement modifiers until all of the shield's critical slots are destroyed (or the shield-carrying arm is destroyed/blown off). Shields cannot be jettisoned.

Shields are primarily used to defend against most weapon and physical attacks (though they cannot protect against damage caused by successful Death-from-Above attacks, Charge attacks, mines, damage from buildings, falls or heat-effect damage). When a shield is used to defend a location against an attack, subtract the Shield's current DA from the attack damage and apply any remaining points to the hit location protected by the shield. (Damage that does not strike a shield is resolved normally.) Regardless of whether or not the damage penetrates the shield, the shield reduces its DC by 1. Weapons using the Cluster Hits table regard every cluster as a separate hit against the shield. Critical hits to the shield subtract 1 from the DA and 5 from the DC, while hits to the actuators of the arm mounting a shield subtract 1 from DA and 1 from DC (double for the shoulder).

To use a shield, the user must declare at the end of his Movement Phase whether the shield is being employed in passive, active or inactive defense modes.

**Active Defense Mode:** In this mode, a shield protects all of the 'Mech's locations except for the rear center torso, the side torso (front and rear) opposite to the shield-using arm, and the opposite-side arm and leg. Weapons mounted in a shield-protected location cannot be used in the same turn the shield is protecting them in active defense mode, nor can a unit using a Shield in this fashion execute a physical attack that involves its protected locations

**Passive Defense Mode:** In this mode, a shield protects only its own arm and the front side torso adjacent to that arm. Weapons and equipment protected by a shield in passive defense mode can be used in the same turn, but at a +2 to-hit modifier. During the Physical Attack Phase, a shield in this mode may also be used to deliver a special attack called a Shield Bash (as long as no other weapons in the shield arm were used in the Weapon Attack Phase). The Shield Bash attacks as a Physical Weapon Attack with a to-hit modifier equal to the value shown in the Shield bash column of the Shield Table below. This attack uses the Hatchet's To-Hit Location Table (see pp. 146-147, *TW*). After a successful Shield Bash, the shield reduces its DC (but not its DA) by 1 point.

**Inactive Defense Mode:** If this mode, the Shield only protects the arm upon which it is mounted and applies a +1 to-hit modifier to any attacks made using that arm.

### 'MECH SHIELD TABLE

Size	DA	DC	Shield Bash	Mobility
Large	7	25	-4	-1MP, No jump
Medium	5	18	-3	-1MP
Small	3	11	-2	—

## SPIKES

**Rules Level:** Experimental

**Available To:** BM, IM

**Tech Base (Ratings):** Inner Sphere (C/X-E-E)

**Game Rules:** Defensively, a cluster of spikes reduces the damage from any successful physical attacks against a spiked location by 4 points (to a minimum of 1) that an Attacker would otherwise inflict. In addition, the attacker suffers 2 points of damage (divided equally) to the body location(s) that delivered the attack (center torso for a 'Mech charge; the appropriate arm for a single-armed punch; the appropriate leg for a kick; both legs for Death From Above; both arms for a push), unless the attack was delivered using a club or other physical attack weapon (like a hatchet).

Offensively, an attacking 'Mech mounting spikes in torso locations may increase the damage inflicted on its opponent during a Charge Attack by declaring such intent before making the to-hit roll. A successful charge with spikes used in this fashion adds 2 points of damage for every torso cluster of spikes the attacking unit has, and absorbs 4 points of damage as normal for any damage groups the Attacker sustains to a spike-protected location.

The Attacker must also roll 2D6 each time a location with spikes suffers damage. On a result of 9 or higher, the cluster suffers a critical hit and is destroyed.

## TALONS

**Rules Level:** Experimental

**Available To:** BM, IM

**Tech Base (Ratings):** Clan (E/X-X-F)

**Game Rules:** When performing a kick or a Death from Above attack, multiply damage by 1.5 (round to nearest whole number; .5 rounds up). If using mixed-technology rules, a unit mounting Talons with Triple-Strength Myomers receives the TSM damage bonus for kick attacks, but not for Death From Above attacks. Critical hits to the Talons or the foot actuator in the leg where they are mounted destroy the Talons.

INTRODUCTION

ADVANCED  
GROUND MOVEMENT

ADVANCED  
COMBAT

ADVANCED  
BUILDINGS

ADVANCED  
SUPPORT  
VEHICLES

GENERAL  
RULES

ADVANCED  
SUPPORT VEHICLE  
CONSTRUCTION

ADVANCED  
WEAPONS  
AND EQUIPMENT

INDEX

RECORD SHEETS

## VIBROBLADE

**R&D Start Date:** 3059 (Draconis Combine)

**Prototype Design and Production:** 3065 (Draconis Combine)

Vibroblade technology has been around for centuries, but only recently has been adapted for use in 'Mech-scale physical combat weapons. Re-

quiring sophisticated cooling and vibration control systems, vibroblades are seen as more suited to the arena of Solaris VII than the battlefield, which is why these high-frequency blades have yet to advance to full-scale production.

## VIBROBLADE

**Rules Level:** Experimental

**Available To:** BM, IM

**Tech Base (Ratings):** Inner Sphere (D/X-X-E)

**Game Rules:** Vibroblade weapons deliver attacks in the same fashion—and with the same modifiers—as a sword (see pp. 146-147, *TW*), but when a vibrosword attack is delivered, the Attacker must declare whether the weapon is activated or deactivated. When active, Vibroblades generate heat (regardless of whether or not the attack succeeds) and deliver the same damage (regardless of the wielder's size, use of special myomers, or actuator damage).

When deactivated, a Vibroblade delivers damage equal to 1 plus the 'Mech's tonnage divided by 10 (rounding up to the nearest whole number). Special myomers and actuator damage modify the damage dealt by unpowered Vibroblades as normal for their rules.

Any hit to the Vibroblade's critical slots disables the blade and renders it useless.

## BATTLEMECH/PROTOMECH MOTIVE SYSTEMS

BattleMechs and ProtoMechs are versatile, all-terrain vehicles with greater flexibility for crossing terrain than perhaps any other ground vehicle, but the endless variety of terrain encountered on the thousands of worlds that bear humankind's battles always turn up some new obstacle. Seeking

new edges in BattleMech mobility, engineers across the Inner Sphere have conceived or developed a series of unusual new motive systems for ProtoMechs, BattleMechs and IndustrialMechs.

### 'MECH JUMP PACK/'MECH DROP PACK

**Introduced:** 2457 (Terran Hegemony)

The BattleMech jump pack was developed to give jump-incapable BattleMechs a surprise edge in the early stages of battle, to help them cross particularly difficult terrain features, or to deploy them in combat drops.

Essentially an externally mounted, self-contained jump jet backpack, the system enables an otherwise ground-bound 'Mech to make a single full-length jump (or a few shorter jumps) in a pinch.

### 'MECH MECHANICAL JUMP BOOSTERS

**R&D Start Date:** 3055 (Federated Commonwealth)

**Prototype Design and Production:** 3060 (Federated Suns)

Intended to provide BattleMechs with heat-free jumping ability, usable even in water, BattleMech mechanical jump boosters use a combination

of special myomer bundles and hydraulic rams to achieve what jump jets accomplish through thrust nozzles and plasma streams. While extremely bulky and heavy, mechanical jump boosters offer a distinct surprise advantage in battle.

### BATTLEMECH/PROTOMECH PARTIAL WING

**R&D Start Date:** 3061 (Jade Falcons ['Mech]), 3063 (Blood Spirits [ProtoMech])

**Prototype Design and Production:** 3067 (Jade Falcons ['Mech]),

3070 (Blood Spirits [ProtoMech])

Building on the aerodynamic traits of the blast deflector design featured on the Clan *Vapor Eagle* (*Goshawk*), and inspired further by reports of the Draconis Combine's Kage light battlesuit, the Jade Falcons began to experi-

ment with the concept of a 'Mech-sized partial wing assembly to extend the effective jumping distance of a BattleMech. Not far behind, the Blood Spirit Clan extended this concept to include ProtoMechs. Though both systems have yet to see widespread production and use, additional benefits have become apparent in the sample models seen to date, such as the additional heat-venting effects made possible by the wings' broad surface area.

**BattleMech Jump Pack:** A 'Mech may carry only one Jump Pack of any desired weight. The additional weight is treated as externally carried cargo (see BattleMech Lifting Capabilities, p. 261, *TW*).

**Mechanical Jump Boosters:** Mechanical Jump Boosters must be placed in all of the 'Mech's legs, and require 2 critical slots per leg to install. Critical damage to any one of these slots disables the entire booster system. The boosters weigh 5 percent of the 'Mech's tonnage for every Jumping MP desired (rounded up to the nearest half ton). Unlike standard jump jets, the Jumping MP bestowed by boosters is not limited by the 'Mech's Walking MP.

**Partial Wings:** BattleMechs, IndustrialMechs and ProtoMechs may mount only one Partial Wing system per unit. The BattleMech Partial Wing weighs 5 percent of the 'Mech's total mass (rounded up to the nearest half ton), and occupies 3 critical slots in each of the unit's side torso locations. The ProtoMech Partial Wing weighs 20 percent of the ProtoMech's total mass and occupies one of the Proto's torso weapon slots. Partial Wings may not be combined with jump boosters (mechanical or otherwise), nor may they be pod-mounted. OmniMechs may mount Partial Wings as fixed equipment. For all units, the Jumping MP bonuses provided by Partial Wings may enable a unit to exceed the normal maximum Jump MPs possible under standard construction.

**BattleMech UMUs:** UMUs are mounted in the same fashion and per the same rules regarding weight and location placement as standard jump jets on both 'Mechs and ProtoMechs (see *TechManual*; p. 51 for BattleMechs, p. 69 for IndustrialMechs and pp. 84-85 for ProtoMechs). Units mounting UMUs may not mount jump jets of any kind, but may mount Mechanical Jump Boosters.

## 'MECH JUMP PACK/'MECH DROP PACK

**Rules Level:** Advanced

**Available To:** PM, BM, IM

**Tech Base (Ratings):** Both (D/C-D-C)

**Game Rules:** The BattleMech Jump Pack provides jumping movement in the same manner as normal jump jets, except that the isolated, chemically fueled pack generates no heat. A unit may carry a jump pack of any weight (in half-ton increments, to a maximum of 20 tons), but the unit's weight will affect how many Jumping MPs the pack can provide per ton of pack weight, as well as the jump pack's "fuel efficiency" in fuel points (as shown in the BattleMech Jump Pack Table below).

To determine the number of Jumping MPs a pack can provide per jump, use the unit's weight to find the number of Jumping MPs provided per ton of Jump Pack weight (Jump MPs per Pack Ton), then multiply that figure by the number of tons the pack weighs (rounding the final result up to the nearest whole MP). The maximum MP for a single jump using a BattleMech Jump Pack is equal to that figure, or to the unit's normal Walking MP (whichever is lower). Thus, a 55-ton BattleMech with a Walking MP of 6, when fitted with a 6-ton Jump Pack, would receive a total of 6 Jump MPs out of a possible 12 (2 Jump MPs per ton of Jump Pack = 12, but the unit's Walk MP is 6, which is lower).

In addition, jump packs carry a limited supply of fuel, which is consumed at a rate of 1 Fuel Point per Jump MP expended. Jump pack fuel loses efficiency with the weight of the jumping unit, and so is reflected in the Jump Pack Table as well under the Jump Pack Fuel column, which provides the total number of points (per ton of Jump Pack, rounded up to the nearest whole point). Thus, the 6-ton Jump Pack affixed to a 55-ton 'Mech would receive 72 points of fuel (12 fuel points per pack ton x 6 tons of Jump Pack = 72 points).

BattleMech Jump Packs are not installed components on a 'Mech, but are strapped to the 'Mech's back torso as unprotected cargo and follow most of the appropriate cargo carrier rules (see p. 261, *TW*). Unlike standard unprotected cargo, however, a jump pack can only be destroyed by a successful attack on a rear torso location (for ProtoMech units, the equivalent result occurs with any hit that strikes the torso through the ProtoMech's rear arc). The pack does not absorb a significant amount of the attack's damage, and so full normal damage still applies to the unit. Once a pack's fuel is exhausted or a pack is destroyed, it is automatically jettisoned.

If used in a combat drop the BattleMech Jump Pack enables a 'Mech that lacks integral jump jets (or a Vehicular Drop Chute) to follow the dropping units rules normally. Jump packs used in this fashion, however, burn up all their fuel during the landing action and jettison immediately upon landing. The rules for dropping troops are covered in *Strategic Operations*.

### 'MECH JUMP PACK TABLE

Unit Weight (in tons)	Jump MPs (per Pack Ton)*	Jump Pack Fuel (Points per Pack Ton)
1 to 5	10	20
6 to 19	5	16
20 to 59	2	12
60 to 89	1	8
90 to 100	0.5	6

\*Jump Packs can be built no larger than 20 tons.

## 'MECH MECHANICAL JUMP BOOSTERS

**Rules Level:** Experimental

**Available To:** BM, IM

**Tech Base (Ratings):** Inner Sphere (E/X-X-F)

**Game Rules:** Mechanical Jump Boosters act like standard jump jets, with the following exceptions:

- BattleMech Mechanical Jump Boosters generate no heat and may be used even underwater.
- Units using BattleMech Mechanical Jump Boosters cannot steer in mid-flight and so begin and end their jumps with the same facing.
- BattleMech Mechanical Jump Boosters may not be used to execute a Death From Above attack.
- While a single unit may mount standard jump jets and Mechanical Jump Boosters, the unit may not use both systems in the same turn.

## BATTLEMECH/PROTOMECH PARTIAL WING

**Rules Level:** Experimental

**Available To:** PM, BM, IM

**Tech Base (Ratings):** Clan (F/X-X-E)

**Game Rules:** Depending on the size of the unit and atmospheric pressure (see p. 54), the Partial Wing confers a bonus to a unit's jump and—in the case of BattleMechs or IndustrialMechs—heat sink capabilities. These benefits are shown in the ProtoMech/BattleMech Partial Wing Performance Table below, with ProtoMech Jumping MP modifiers shown in the ProtoMech Jumping MP Bonus column, and the 'Mech jump modifiers (divided by weight class) under the 'Mech Jumping MP Bonus columns. The values in the 'Mech Heat Modifier column are applied during the Heat Phase of any turn in which the Partial Wing is functional (regardless of whether or not the unit actually used the system). Note, however, that the added Jumping MP bonus does not apply if the unit has no functioning jump jets (or equivalent jumping system, such as mechanical jump boosters), but may allow for jumps beyond the unit's normal maximum Jump MP limits.

Each critical hit suffered by a BattleMech Partial Wing reduces the wing-provided jump bonus by 1, to a minimum of 0. A critical hit against a ProtoMech's Partial Wing destroys the wing assembly.

continued on p. 294

INTRODUCTION

ADVANCED  
GROUND MOVEMENT

ADVANCED  
COMBAT

ADVANCED  
BUILDINGS

ADVANCED  
SUPPORT  
VEHICLES

GENERAL  
RULES

ADVANCED  
SUPPORT VEHICLE  
CONSTRUCTION

ADVANCED  
WEAPONS  
AND EQUIPMENT

INDEX

RECORD SHEETS

**Beast-Mounted Infantry:** The Beast-Mounted Infantry Types Table below provides data for the most common (and a few uncommon) beast-mounted infantry types. This information includes the creature's *Type* (its common name) its *Size* (Large, Very Large or Monstrous) and *Weight* (excluding any human riders, used to compute the platoon's transport weight). Also given are the creature's MPs (including its *Movement Type*: Ground, Submarine, or VTOL), *Bonus Damage* (the amount of damage points the creature adds when attacking other conventional infantry and vehicles in the same hex) and *Damage Divisor* (the value used to divide any damage the unit receives in combat). Finally, the table provides any *Terrain Restrictions* the mounted infantry unit suffers.

The Creature Size Table notes the maximum number of troops that can ride on a creature (*Troops/Creature*), the maximum number of creatures that may be deployed per platoon (*Creatures/Platoon*) and the to-hit modifier that applies to any attacks against the beast-mounted infantry platoon (*Attacker To-Hit*). Finally, any relevant game play restrictions or platoon construction modifications are provided as *Additional Rules*.

After determining a beast-mounted infantry unit's creature type, the platoon may be armed per standard conventional infantry construction rules. Note, however, that infantry mounted on Large-size creatures may not carry support weapons, while infantry mounted on Monstrous-sized creatures may employ up to 3 support weapons per beast. These support weapon allowances modify the standard support weapon limits per squad as established in *TechManual*, and reduce the crew needs for support weapons, but no single creature can carry more support weapons than its riders can provide crew for. For example, while the Monstrous-sized hipposaurus could carry three support weapons, its rider limit (*Troops/Creature*) of 4 means these three support weapons cannot be Inner Sphere ER heavy support lasers, as each requires 2 crewmen per weapon on the beast's mount (crew  $4 \div 2 = 2$ ).

For transport purposes, total the weight of all creatures in the platoon, plus the weight of all troopers (factored in as 0.2 tons each, to reflect the rider plus any riding gear such as harnesses). Beast-mounted platoons may not be "broken down" for transport purposes to any weight less than that of a single creature plus its riding trooper(s).

## BEAST-MOUNTED INFANTRY SAMPLE TYPES TABLE

Creature Type	Creature Size	Weight*	MP (Type)	Bonus Damage vs. Infantry (Vehicles)	Damage Divisor	Terrain Restrictions
Donkey	Large	0.15 ton	2 (Ground)	0 (0)	1.0	Water (Depth 1+)
Coventry Kangaroo	Large	0.11 ton	3 (Ground)	+1D6 (1)	1.0	Water (Depth 1+)
Horse	Large	0.5 ton	3 (Ground)	0 (0)	1.0	Water (Depth 1+)
Camel	Large	0.65 ton	2 (Ground)	0 (0)	1.0	Water (Depth 1+)
Branth	Large	0.72 ton	6 (VTOL)†	+2D6 (1)	1.0	As VTOLs (see <i>TW</i> , p. 54)
Odessian Raxx	Large	2.4 tons	2 (Ground)	+1D6 (1)	1.0	Water (Depth 1+)
Tabiranth	Large	0.25 ton	2 (Ground)	+1D6 (1)	1.0	Water (Depth 1+)
Tariq	Large	0.51 ton	5 (Ground)	0 (0)	1.0	Water (Depth 1+)
Elephant	Very Large	6.0 tons	2 (Ground)	+1D6 (1)	2.0	Water (Depth 2+)
Orca	Very Large	7.2 tons	5 (Submarine)**	+2D6 (1)	2.0	As Submarines (see <i>TW</i> , p. 56-57)
Hipposaur	Monstrous	35.5 tons	2 (Submarine)**	+10D6 (4)	4.0	1 Ground MP on Land

\*Per creature; does not include that of the riding trooper(s), each of which is worth 0.2 tons.

\*\*Infantry using submarine-capable creatures must use SCUBA gear; Orcas must surface once every 180 turns to breathe; Hipposaurs must surface once every 2 turns.

†VTOL-capable creatures may not operate on the High Altitude Map and must spend 1 MP per turn, even if remaining stationary.

## CREATURE SIZE TABLE

Size Class	Troops/Creature	Creatures/Platoon	Attacker To-Hit	Additional Rules
Large	1	21	+0	May not carry Support Weapons; +0 MP to enter buildings (0 CF damage)
Very Large	2	7	-1	May carry up to 2 Support Weapons per creature with no MP loss (divide weapon crew needs by 2 and round up); +1 MP to enter buildings (2 CF damage)*; No Anti-Mech Swarm Attacks
Monstrous	4	2	-2	May carry up to 3 Support Weapons per creature with no MP loss (divide weapon crew needs by 2 and round up); +2 MP to enter buildings (4 CF damage)*; No Anti-Mech Leg or Swarm Attacks

\*In addition to standard infantry Building MP modifiers; CF damage applies per platoon when entering or exiting the structure and for each hex moved inside the building.

## BATTLEMECH/PROTOMECH PARTIAL WING (CONT.)

### BATTLEMECH/PROTOMECH PARTIAL WING PERFORMANCE TABLE

Atmospheric Pressure (Density)	ProtoMech Jumping MP Bonus	'Mech Jump MP Bonus		Heat Modifier
		Light/Medium	Heavy/Assault	
Vacuum	+0	+0	+0	+0
Trace	+1	+0	+0	-1
Thin	+2	+1	+0	-2
Standard	+2	+2	+1	-3
High	+3	+2	+2	-3
Very High	+3	+3	+2	-3

### 'MECH UMU SYSTEM

**R&D Start Date:** 3062 (Lyran Alliance), 3057 (Goliath Scorpions)  
**Prototype Design and Production:** 3066 (Lyran Alliance), 3061 (Goliath Scorpions)

Derived from the Underwater Maneuvering Unit (UMU) employed by the Undine battlesuit, Inner Sphere and Clan engineers have created a scaled-up version for use on 'Mechs. Though proven in the aquatic arenas on Solaris VII before the Jihad, 'Mech-scale UMUs remain in the prototype stage, as most field commanders consider them more a novelty than a practical motive system.

### 'MECH UMU SYSTEM

**Rules Level:** Experimental

**Available To:** PM, BM, IM

**Tech Base (Ratings):** Both (E/X-X-E)

**Game Rules:** UMUs cannot be used to move into or out of water, and have no effect on the unit's movement while it is not completely submerged. When underwater, a unit can use its UMUs to maneuver like a submarine, receiving 1 Cruising MP per operational UMU. Flank movement is not possible using UMU, however, and the normal hull breach and crush depth rules apply (pp. 121, *TW*, and 42, respectively). If a unit with UMUs descends to the bottom of a body of water, the unit may disengage its UMUs to move along the floor per the normal submerged Walking movement rules (see pp. 56-57, *TW*, and *Extreme Depths*, p. 42). While the UMUs are disengaged, all standard rules for moving underwater apply.

Use of UMUs imposes a +3 attacker movement modifier on all attack to-hits made by the UMU-equipped unit, as though the unit were jumping. However, UMUs generate only 1 heat point per turn total, regardless of the number of UMU MPs used.

Remember that a BattleMech occupies 2 levels (in this case depths) in height for line of sight purposes and move in an upright position while using UMUs, even when fully submerged. A unit employing UMUs should identify its submerged depth based on the location of its feet relative to the water surface, as an upright 'Mech within 1 depth of the surface is considered only partially submerged, and may no longer employ UMU movement.

## BEAST-MOUNTED INFANTRY

**Introduced:** Pre-spaceflight

The thousands of worlds where humanity has made its home across the Inner Sphere, Periphery and even Clan space include an almost limitless range of biospheres, giving rise to a staggering variety of alien fauna. As humanity expanded, many of these beasts were predators to be overcome, sources for food, or—in the absence of heavy industry—a convenient mode of transportation.

In the centuries that humankind has walked among the stars, literally thousands of new and different alien creatures have joined the ranks of the donkey, the horse and the camel as favored mounts for civilian transportation and in battle. Though rarely seen in modern mechanized warfare, the image of horse-mounted soldiers challenging combat vehicles is not unknown to the outer reaches of the Successor States and the Periphery, where armed warriors raise and train creatures that benefit from life-long adaptations to local terrains and climates.

### BEAST-MOUNTED INFANTRY

**Rules Level:** Advanced

**Available To:** CI

**Tech Base (Ratings):** Both (A/A-A-A)

**Game Rules:** Depending on the creature types used by a beast-mounted infantry unit, the speed, motive type, transport weight and damage absorption capabilities of the platoon will vary. These values—as well as any additional damage that the creatures themselves may inflict against other units, and special restrictions based on the creatures' size or type—are presented in the Beast-Mounted Infantry Types Table below.

For movement, beast-mounted infantry use the appropriate movement rules for their creatures' MP type (ground movement for Ground MP, Submarine movement for Sub MP and VTOL movement for VTOL MP), but with terrain restrictions as noted in the appropriate creature's entry. These

continued on page 296

INTRODUCTION

ADVANCED  
GROUND MOVEMENT

ADVANCED  
COMBAT

ADVANCED  
BUILDINGS

ADVANCED  
SUPPORT  
VEHICLES

GENERAL  
RULES

ADVANCED  
SUPPORT VEHICLE  
CONSTRUCTION

ADVANCED  
WEAPONS  
AND EQUIPMENT

INDEX

RECORD SHEETS

## BEAST-MOUNTED INFANTRY (CONTINUED)

restrictions may be further modified by the creature's size (beast-mounted infantry may not use the mechanized infantry rules, however, and may not be deployed as mechanized infantry).

When delivering ranged attacks, beast-mounted infantry units use standard infantry combat rules, based on the number of surviving troopers in the platoon. Furthermore, against targets at point-blank range (0 hexes), some beast-mounted infantry may add extra damage to their base attack in the form of a bonus attack from the riding creatures. This Bonus Damage is listed on the table with two values. The first, outside the parentheses, reflects the additional "burst-fire" damage the beast-mounted unit applies against conventional infantry. The second, inside the parentheses, reflects the additional damage the creatures can inflict (per platoon) against other units such as battle armor, vehicles and 'Mechs.

The size of some creatures used by beast-mounted infantry—also presented on the Beast-Mounted Infantry Table—can impair the unit's ability to conduct Anti-'Mech Leg or Swarm attacks. For units using Very Large creatures (roughly the size of a Terran elephant), the unit may not engage in Leg Attacks. Units riding Monstrous-sized creatures (roughly the size of a Terran humpback whale) may not make anti-'Mech attacks.

Attacks by other units against a beast-mounted infantry unit are resolved in the same basic fashion as attacks made against other conventional infantry, but with a to-hit modifier based on the creatures' size category (Large creatures apply no modifier, Very Large creatures apply a -1 modifier and Monstrous creatures provide a -2 modifier). In addition, thanks to the creatures' added body mass, the amount of damage applied to the platoon is modified by a damage divisor in the same fashion as infantry armor (see p. 317). This value divides the damage points (or, where applicable, the damage dice) inflicted by the attack *before* resolving it against the infantry unit per standard rules (see pp. 215-217, *TW*). Round all final damage values up. For example, if an elephant-mounted infantry platoon is attacked by an AC/20 and a Light Machine Gun, the weapons' damage would be resolved after first dividing the AC's 20-point hit and the Light Machine Gun's 1D6 hit by the platoon's Damage Divisor (2.0), which reduces the AC to a base 10-point hit and the Light Machine Gun to 1/2 D6 (or 1D3); as the AC/20 is a direct-fire ballistic weapon, this damage is again divided by 10, killing 1 trooper, while the Light Machine Gun rolls a 5 on 1D6 and divides the result by 2, rounding up for 3 more troopers killed.

## BLUE SHIELD PARTICLE FIELD DAMPER

**R&D Start Date:** 3051 (Federated Commonwealth)

**Prototype Design and Production:** 3053 (Federated Commonwealth)

The density of magnetic shielding required to protect units from PPCs was generally considered too high to be practical for battlefield units, but

that did not stop NAIS researchers from trying. The resulting technology—the Blue Shield particle field damper—promised a useful degradation of PPC damage for the weight investment, but remains experimental and thoroughly detested by the techs and astechs who must maintain the system.

## BLUE SHIELD PARTICLE FIELD DAMPER (PFD)

**Rules Level:** Experimental

**Available To:** BM, IM, CV, SV, AF, CF

**Tech Base (Ratings):** Inner Sphere (E/X-X-F)

**Game Rules:** When active, the Blue Shield reduces damage from all non-capital PPCs (including infantry particle cannons) by half (rounded down, to a minimum of 1 point).

The Blue Shield may be activated and deactivated during the End Phase of any turn. If a unit is equipped with a Null-Signature System or Stealth Armor, the stealth benefits of those systems are negated while the Blue Shield is active (due to system conflicts). Additionally, a unit with Blue Shield active cannot be hidden (see p. 259, *TW*). If a unit mounts both the Blue Shield and Laser Reflective Armor (see p. 281), whenever the Blue Shield is active, halve PPC damage first for the Blue Shield and round down, then halve again for the Reflective Armor and round down again. For example, a Heavy PPC's Damage Value of 15 against such a target would be reduced to 7.5, rounded down to 7 (for the Blue Shield), then reduced to 3.5, rounded down to 3 (for the Reflective Armor), with a final Damage Value of 3 assigned to the target.

For non-fighter units, constant use of the system creates an increasing risk of system failure due to the dust and debris being drawn to the field generators; these turns do not need to be consecutive, but instead accumulate across an entire scenario. For the first 6 turns the shield is active, it is error-free. After the sixth turn of use, however, the controlling player must roll 2D6 at the beginning of the turn to see if the Blue Shield fails. The base chance for failure is 2, plus 1 for each turn after the sixth; if the roll is less than the value, the system fails. If the system fails, it shuts down and will not provide its protection for the rest of the scenario (though it may be automatically "cleaned" between scenarios with no additional expenditure of time or effort).

Finally, anytime a Blue Shield is active and one of its slots receives a critical hit, the hit results in a 5-point ammunition explosion in that location (with all the attendant effects, including warrior damage from feedback) and the system will no longer function for the remainder of the scenario. Subsequent critical hits to Blue Shield slots soak up critical hits and make repairs more difficult, but cause no further explosions and have no additional game play effect. If CASE is present in a location where a Blue Shield explodes, the CASE system will contain the internal damage in the same fashion as an ammo explosion. An inactive Blue Shield (turned off or shut down by damage) will not explode if it suffers a critical hit.

**Blue Shield Particle Field Damper (PFD):** In addition to its 3-ton weight, the Blue Shield occupies 1 critical slot in every location except the head. In vehicles and fighters, this item occupies 1 equipment slot per location (front, sides/wings and aft, including turrets if present), but is centrally located in the unit's body and thus does not add to turret weight. Blue Shield is a permanent installation that may not be pod-mounted.

**Booby Trap:** A unit may carry a maximum of 1 Booby Trap. For all units except for Mobile Structures, the Booby Trap takes up 10 percent of the unit's total weight (rounded up to the nearest half ton for units 5 tons and over, or to the nearest kilogram for units under 5 tons). The Booby Trap must be placed in the same location as the unit's engine (the center torso for 'Mechs, the body for vehicles and fighters, and so forth).

For Mobile Structures, each hex must devote 2 tons per level of structure to a Booby Trap device.

# BOOBY TRAP

**Introduced:** Pre-spaceflight

Long a tactic of the desperate and the fanatical, booby traps have been used to deny spoils to a victorious enemy, or to deliver a devastating close-quarters attack after all other weapons have failed.

Though modernized for the mechanized battlefield, the concept of a highly explosive "spoilsport" weapon remains too extreme to become a

mainstream weapon system (indeed, the practice went nearly extinct in the centuries after the fall of the first Star League, and the Clans do not seem to employ such devices at all). However, some forces—most notably those of the Capellan Confederation, Taurian Concordat and the Word of Blake—have been known to use booby traps en masse.

## BOOBY TRAP

**Rules Level:** Experimental

**Available To:** BM, IM, CV, SV, AF, CF, SC, DS, JS, WS, SS, MS

**Tech Base (Ratings):** Inner Sphere (B/D-F-D)

**Game Rules:** The Booby Trap is a one-shot device that can be activated during a unit's Weapon Attack or Physical Attack phase, regardless of the unit's engine type. Once activated, a Booby Trap explodes immediately, destroying the booby-trapped unit completely (leaving nothing for salvage).

The controlling player of a unit that activates its Booby Trap may attempt to use any on-board ejection systems to save the warrior or crew at the same time, but must apply a +4 modifier to the target number for a successful ejection (see p. 196), in addition to any modifiers based on the ejection system used. If successful, the ejected warriors or crews land outside the exploding unit's hex (either adjacent to it or a number of hexes away, based on the ejection system used) in the following turn.

In ground combat, the damage inflicted by a Booby Trapped unit is treated as area-effect damage similar to an artillery blast. Against all units in the same hex as the exploding unit, this damage is equal to the booby-trapped unit's Engine Rating. If the unit has no Engine Rating, multiply its Cruising or Safe Thrust MP by its tonnage and use that value in place of the Engine Rating (to a maximum of 500). For Mobile Structures, multiply the structure's MP value by its size in hexes times its height in levels, and use that value for Engine Rating (again, to a maximum of 500). In addition, against all units 1 hex away from the exploding unit, the Booby Trap inflicts damage equal to the exploding unit's Engine Rating, divided by 2. This damage is halved again (to one-quarter of the unit's Engine Rating) against units located 2 hexes away, and again (to one-eighth the Engine Rating) against units 3 hexes away. Round all fractions up. Units 4 hexes or more away from an exploding booby-trapped unit suffer no damage.

Airborne units that employ a Booby Trap inflict no damage to other units unless another airborne unit is in the same hex on the Low Altitude map (or, if a non-aerospace airborne unit, within 3 hexes and elevations of the exploding Booby Trapped unit). In such an event, the other airborne unit must make a Control Roll/Piloting Skill Roll when the Booby Trap explodes. If this roll fails, the other airborne unit suffers damage equal to one-quarter of the exploding unit's Engine Rating (as computed above). Aerospace units operating on the space map that activate a Booby Trap inflict no damage to nearby units.

If an atmosphere is present and the underlying terrain is not water, the hex occupied by an exploding Booby Trapped unit is filled with fire after the unit's destruction. Critical hits to a Booby Trap will not set off the device, but will simply disable its arming systems, rendering it inoperable.

# C<sup>3</sup> SYSTEMS

Buoyed by the success of battlefield Command, Control and Communications (C<sup>3</sup>) networks, further experimentation before and into the Jihad has focused on expanding the potential of this relatively new frontier in electronic warfare.

**Game Rules (General):** The various advanced C<sup>3</sup> systems here are designed to complement the C<sup>3</sup> computer systems described on pp. 131-133 in *Total Warfare* and will follow all rules for such systems except where otherwise noted below.

## BATTLE ARMOR C<sup>3</sup> / C<sup>3</sup>I (BC<sup>3</sup>/BC<sup>3</sup>I)

**R&D Start Date:** circa 3058 (Word of Blake [BC<sup>3</sup>I]),

circa 3064 (Draconis Combine [BC<sup>3</sup>])

**Prototype Design and Production:** 3063 (Word of Blake [BC<sup>3</sup>I]),

3073 (Draconis Combine [BC<sup>3</sup>])

The Word of Blake evidently derived the development of battle armor-scale C<sup>3</sup> systems (dubbed "BC<sup>3</sup>" systems) from the cybernetics capabilities of their own elite Manei Domini, whose communications and computer

implants enhance their battlefield coordination dramatically. Since then, the technology—which uses a more distributed and semi-redundant wireless network to form a squad-sized "unit"—has made implant-free battlesuit-scale C<sup>3</sup> a demonstrated possibility. Many prototype systems have emerged on the battlefield, first among other Blakist commands, but eventually trickling down to the Houses engaged against them, many of which were already working on similar projects.

## BATTLE ARMOR C<sup>3</sup> / C<sup>3</sup>I (BC<sup>3</sup>/BC<sup>3</sup>I)

**Rules Level:** Experimental

**Available To:** BA

**Tech Base (Ratings):** Inner Sphere (E/X-X-E)

**Game Rules:** In game play, a BC<sup>3</sup>/BC<sup>3</sup>I-equipped Battle Armor squad functions as a single unit equipped with an appropriate C<sup>3</sup> Slave (for BC<sup>3</sup>) or C<sup>3</sup>i (for BC<sup>3</sup>I) system, enabling them to join into an appropriate network (though existing limits for the network apply). Even though BC<sup>3</sup> and BC<sup>3</sup>I are distributed across the squad, the entire battle armor squad counts as 1 unit in an appropriate C<sup>3</sup> network.

All troopers in a full BC<sup>3</sup>/BC<sup>3</sup>I Battle Armor squad must have the same type of BC<sup>3</sup>/BC<sup>3</sup>I system to receive these abilities. A squad with less than 3 troopers (either from the start of the scenario or reduced through damage) loses all benefits from its BC<sup>3</sup>/BC<sup>3</sup>I system.

INTRODUCTION

ADVANCED  
GROUND MOVEMENT

ADVANCED  
COMBAT

ADVANCED  
BUILDINGS

ADVANCED  
SUPPORT  
VEHICLES

GENERAL  
RULES

ADVANCED  
SUPPORT VEHICLE  
CONSTRUCTION

ADVANCED  
WEAPONS  
AND EQUIPMENT

INDEX

RECORD SHEETS

## C<sup>3</sup> BOOSTED SYSTEM (C<sup>3</sup>BS)

**R&D Start Date:** 3069 (Federated Suns)

**Prototype Design and Production:** 3073 (Federated Suns)

Only recently entering prototype stage, the C<sup>3</sup> Boosted System (C<sup>3</sup>BS) is

actually a hardware-upgraded variation on the standard C<sup>3</sup> network systems that FedSuns engineers designed to render their networks immune to hostile ECM.

### C<sup>3</sup> BOOSTED SYSTEM (C<sup>3</sup>BS)

**Rules Level:** Experimental

**Available To:** BM, IM, CV, SV, AF, CF, MS

**Tech Base (Ratings):** Inner Sphere (E/X-X-F)

**Game Rules:** Units use the C<sup>3</sup>BS system (Master and Slaves) in the same fashion and with the same limitations as a standard C<sup>3</sup> network, but experience no interference from hostile ECM equipment (except for the Angel ECM Suite). As with a conventional C<sup>3</sup> network, the C<sup>3</sup>BS network requires a functioning Master unit in order to work. The loss of the C<sup>3</sup>BS Master will disable the entire network.

## C<sup>3</sup> EMERGENCY MASTER (C<sup>3</sup>EM)

**R&D Start Date:** 3066 (Draconis Combine)

**Prototype Design and Production:** 3071 (Draconis Combine)

With the broadening use of C<sup>3</sup> technology on the battlefield, DCMS field commanders gradually noticed that opponents had learned to target their C<sup>3</sup> Master units in order to destroy the entire network and (presumably) remove the field commander from the fight. To combat this, researchers

developed a redundant unit that could back up a destroyed C<sup>3</sup> Master in the event of destruction or ECM interference. Though functional, prototypes of these so-called C<sup>3</sup> Emergency Master (C<sup>3</sup>EM) units lack the computing power of a primary C<sup>3</sup> Master, and can only function for a minute before being overwhelmed by incoming data.

### C<sup>3</sup> EMERGENCY MASTER (C<sup>3</sup>EM)

**Rules Level:** Experimental

**Available To:** BM, IM, CV, SV, AF, CF, MS

**Tech Base (Ratings):** Inner Sphere (E/X-X-F)

**Game Rules:** A C<sup>3</sup> Emergency Master duplicates the operation of a C<sup>3</sup> Slave unit and functions as a C<sup>3</sup> Master unit for up to 6 consecutive turns after the network's C<sup>3</sup> Master unit is destroyed or rendered inoperable by ECM. (Do not count any turns where the C<sup>3</sup>EM unit itself is in a hostile ECM bubble, however, as the system will simply go into standby mode during such interference. A C<sup>3</sup>EM may not be deliberately switched off once activated.) After 6 operating turns, a C<sup>3</sup>EM will shut down from overload and may not be reused until it can be reset after the scenario.

The C<sup>3</sup>EM cannot function as a TAG unit, whether or not the network's C<sup>3</sup> Master unit is functioning.

## C<sup>3</sup> REMOTE SENSOR (C<sup>3</sup>RS) LAUNCHER

**R&D Start Date:** 3070 (Draconis Combine)

**Prototype Design and Production:** 3072 (Draconis Combine)

Another development dreamed up by the DCMS, the C<sup>3</sup> Remote Sensor Launcher (C<sup>3</sup>RS) is a specialized variant of the now-familiar Narc

launcher system. Intended to fill gaps in a damaged or incomplete C<sup>3</sup> network, properly deployed C<sup>3</sup> remote sensors can be a boon in battle, even though their reduced size, power and non-existent mobility limits their battlefield lifespan.

**Battle Armor C<sup>3</sup>/C<sup>3</sup>i:** BC<sup>3</sup> and BC<sup>3</sup>i may be mounted on any battle armor suit in accordance with standard construction rules. A battlesuit may carry only one BC<sup>3</sup> or BC<sup>3</sup>i unit (and all troopers in the squad must feature an identical type to gain the network's benefits).

**C<sup>3</sup> Boosted Slave:** C<sup>3</sup>BS Master and Slave units may be mounted on any available unit in accordance with the unit's standard construction rules.

**C<sup>3</sup> Emergency Master:** The C<sup>3</sup> Emergency Master may be mounted on any available unit in accordance with the unit's standard construction rules.

**C<sup>3</sup> Remote Sensor Launcher:** C<sup>3</sup> Remote Sensor Launchers may be mounted on any available unit type in accordance with the unit's standard construction rules.

**CASE II:** As with the standard CASE system, CASE II is required for each location to be protected by it, and protects all ammo bins and other explosive components in that location against explosions. CASE II may be pod-mounted as part of an Omni unit. Units built using either technology base can place CASE II in any body location. A unit using CASE II may also mount standard CASE in the same (or different) locations, if desired.

**Chaff Pod:** Chaff Pods may be mounted as weapons on all available units, in accordance with the unit's standard construction rules.

## C<sup>3</sup> REMOTE SENSOR (C<sup>3</sup>RS) LAUNCHER

**Rules Level:** Experimental

**Available To:** BM, IM, CV, SV, SC, MS

**Tech Base (Ratings):** Inner Sphere (E/X-X-F)

**Game Rules:** The C<sup>3</sup> Remote Sensor Launcher functions as a standard Narc missile launcher, except that the Attacker may only target a hex location, rather than another unit. Upon a successful attack, the launcher places a remote C<sup>3</sup> sensor pod in the target hex that automatically activates in the following turn and functions as a stationary C<sup>3</sup> Slave. The player launching a C<sup>3</sup> Remote Sensor must declare the network to which the sensor will be slaved before the attack, and may not change this assignment once the sensor is deployed. A deployed sensor pod cannot expand C<sup>3</sup> networks beyond the network size limits (see pp. 131-133, *TW*). Furthermore, because its computing power is limited, a C<sup>3</sup> Remote Sensor functions for only 3 full turns after the turn in which it is launched. C<sup>3</sup> Remote Sensors deployed while a network is "full" will have no effect.

On an unsuccessful C<sup>3</sup> Remote Sensor launch (or a to-hit roll result of 2), the sensor pod is destroyed on impact. Deployed sensors can also be destroyed if any weapon capable of delivering more than 2 points of damage successfully attacks the sensor itself. (Attacking the sensor in this fashion applies a +2 to-hit modifier due to the sensor's small size, as well as any standard terrain modifiers and the -4 immobile target modifier.) Critical hits to a C<sup>3</sup> Remote Sensor Launcher's "ammo" will cause 2 points of damage per unfired pod.

The C<sup>3</sup> Remote Sensor system is incompatible with C<sup>3</sup>i-based systems.

## CASE II

**R&D Start Date:** 3057 (Free Worlds League), 3059 (Clan Coyote)

**Prototype Design and Production:** 3064 (Free Worlds League), 3062 (Clan Coyote)

In the late 3050s and early 3060s, the Inner Sphere and the Clans independently launched projects aimed at refining the benefits of Cellular Ammunition Storage Equipment (CASE). After many attempts, both suc-

ceeded in prototype deployment of an advanced version of the standard CASE system—dubbed CASE II—just a few years before the start of the Jihad. Though CASE II is bulkier and heavier than the standard (forcing designers to trade off weapons, armor or heat sinks to accommodate the technology), it is stronger and far more effective at channeling internal explosions away from the unit.

## CASE II

**Rules Level:** Experimental

**Available To:** BM, IM, AF, CF

**Tech Base (Ratings):** Inner Sphere (E/X-X-F), Clan (F/X-X-F)

**Game Rules:** When ammunition protected by CASE II explodes, only 1 point of internal damage is inflicted to the location (with the normal chance of critical effects), while any remaining damage is applied to the location's rear armor and does not transfer after that. (For fighters, CASE II reduces ammunition explosion effects against such units—such as described on p. 261, *TW*—to 1 point against the unit's SI.) Furthermore, for any critical hits rolled up as a result of an ammunition explosion vented by CASE II, the controlling player rolls 2D6 again for each one, and disregards the critical effects on a result of 8+. Otherwise, the critical hit applies as normal.

CASE II does not protect against pilot damage from internal explosions.

## CHAFF POD

**R&D Start Date:** 3066 (Lyran Alliance)

**Prototype Design and Production:** 3069 (Lyran Alliance)

Developed as a temporary "active defense" against guided missiles and targeting systems, chaff pods release a mixture of metallic confetti and

particles in a cloud around the unit that confounds electronic sensors and targeting gear. Though similar in effect to a dedicated anti-missile system with additional ECM benefits, their one-shot nature and requisite manual-release controls can limit the pods' effectiveness in battle.

## CHAFF POD

**Rules Level:** Experimental

**Available To:** BM, IM, CV, SV, AF, CF, SC, DS, MS

**Tech Base (Ratings):** Inner Sphere (C/X-X-E)

**Game Rules:** A unit using a Chaff Pod must declare its use at the end of the unit's Movement Phase. In ground combat, each activated Chaff Pod fills the unit's hex with a cloud of obscurants 2 elevations in height. This cloud is treated as a hex of light smoke for LOS purposes (see p. 47), as well as a 1-hex "bubble" of ECM (see p. 134, *TW*). Furthermore, the chaff cloud acts as an anti-missile system (see pp. 129-130, *TW*) for all missile attacks made against units within the clouded hex, except those delivered by standard MRMs or Rocket Launchers. These effects last only during the Weapon and Physical attack phases of the turn in which the pod is activated; the obscurants settle and dissipate during the End Phase.

Chaff Pods have no effect in vacuum or space combat, but may be used by landed or airborne aerospace units operating in atmosphere at any altitude for the same effects.

The Chaff Pod is a one-shot item. Unfired pods explode for 3 points of damage each if they suffer a critical hit.

INTRODUCTION

ADVANCED  
GROUND MOVEMENT

ADVANCED  
COMBAT

ADVANCED  
BUILDINGS

ADVANCED  
SUPPORT  
VEHICLES

GENERAL  
RULES

ADVANCED  
SUPPORT VEHICLE  
CONSTRUCTION

ADVANCED  
WEAPONS  
AND EQUIPMENT

INDEX

RECORD SHEETS

# CHAMELEON LIGHT POLARIZATION SHIELD

**Introduced:** 2630 (Terran Hegemony)

**Extinct:** 2790 (Inner Sphere)

**Recovered:** N/A

Created by the first Star League, the so-called Chameleon light polarization shield uses a primitive mimetic system to help mask the 'Mech on which it is installed from visual observation at long and extreme range.

While it does not render the unit truly invisible, the effect does blur its outline, making the 'Mech harder to identify or attack. Seen historically as the crown jewel in the design of the *Exterminator* BattleMech, it is commonly misbelieved that all *Exterminator* models sported the LPS system, when in fact only a fraction of those units were so equipped—virtually all of which were lost to the Succession Wars.

## CHAMELEON LIGHT POLARIZATION SHIELD (LPS)

**Rules Level:** Experimental

**Available To:** BM

**Tech Base (Ratings):** Inner Sphere (E/F-X-X)

**Game Rules:** A player may turn the light polarization shield on or off during the End Phase of any turn (or start the game with the system already engaged). While the shield is active, the 'Mech is more difficult to attack at long distance. Medium-range attacks receive an additional +1 to-hit modifier, and Long- or Extreme-range attacks receive an additional +2 to-hit modifier. Unlike most other stealth systems, these modifiers apply even if the attacking unit is infantry. A hit to any of the shield's critical slots (or the destruction of any hit location containing one) destroys the entire system.

While active, the light polarization shield generates 6 points of heat. If used in conjunction with an active Null-Signature System (see p. 336), all modifiers are cumulative.

# COCKPIT SYSTEMS

Experimented with since the dawn of the BattleMech, a variety of cockpit system types have been tested on and off for centuries. Rare since the fall of the

Star League, occasionally a company will test a new version of a cockpit, only to find that the standard system remains the best for command and control.

## COCKPIT COMMAND CONSOLE

**Introduced:** 2631 (Terran Hegemony)

**Extinct:** circa 2850

**Recovered:** circa 3030

Actually little more than a second cockpit mounted behind the main console, the Cockpit Command Console allows a high-level commander to

focus on "real time" strategy in the field, while largely leaving a unit's operation to its pilot. First employed during the Star League era, but lost to the Succession Wars' scavenger culture, some command units today occasionally sport modified cockpits that mimic these "dual cockpit" systems.

## SMALL AEROSPACE COCKPIT

**Introduced:** 3070 (Word of Blake)

An adaptation of the 'Mech-style small cockpit, the compact cockpit

for aerospace fighters achieves the same weight-saving effects at an equal impact on pilot performance.

## TORSO-MOUNTED COCKPIT

**R&D Start Date:** 3044 (Federated Commonwealth)

**Prototype Design and Production:** 3053 (Federated Commonwealth)

The most recent attempt to move the cockpit from the most structurally vulnerable part of a 'Mech to its more heavily armored center torso offered

the pilot added physical protection, but remained laced with other hazards, not the least of which included ejection difficulties, dangerous proximity to the engine and the paradoxically increased likelihood of suffering physical damage in combat. For these reasons, the concept remains prototypical.

**Chameleon Light Polarization Shield (LPS):** The light polarization shield system does not take up tonnage, but takes up 6 critical slots (1 in each of the 'Mech's limbs and 1 each in the left and right side torsos). The Light Polarization Shield cannot be combined with Stealth Armor or the Void-Signature System and may not be pod-mounted on an OmniMech (though Omni units may incorporate the technology into their base chassis).

**Cockpit Command Console:** Cockpit Command Consoles must always be placed in the same location as the primary cockpit (usually the head of a 'Mech or the body of a vehicle).

**Small Aerospace Cockpit:** The Small Aerospace Cockpit can only be mounted in aerospace fighters, in place of the standard cockpit.

**Torso-Mounted Cockpit:** Torso-mounted cockpits replace the standard cockpit and weigh 4 tons. Torso cockpits occupy 2 slots in the unit's center torso: 1 slot for the cockpit and 1 for its added sensor package. In addition, the head's Life Support slots are moved (1 slot each) to the left and right side torsos. Now devoid of cockpit and life support systems, the head retains only the 2 default sensor critical slots. Torso-mounted cockpits may not be used in conjunction with a Standard or Small cockpit and may not be used in conjunction with a Cockpit Command Console.

**Collapsible Command Module (CCM):** The Collapsible Command Module may be mounted on a 'Mech in accordance with the unit's standard construction rules.

## COCKPIT COMMAND CONSOLE

**Rules Level:** Advanced

**Available To:** BM, IM, CV, SV, AF, CF

**Tech Base (Ratings):** Both (D/C-F-E)

**Game Rules:** A unit using a Cockpit Command Console adds a second MechWarrior damage condition monitor to its record sheet, to reflect the commander occupying the command console. During any End Phase, this “secondary warrior” may swap positions with the unit’s pilot (or vehicle commander), effectively becoming the unit’s pilot (or vehicle commander) while the other warrior takes on the secondary position.

For ‘Mech and fighter units (but not vehicles), the secondary warrior suffers no damage from ammunition explosions, though heat effects and damage done to the cockpit location (or vehicle commander slot) does affect both warriors. (In a ‘Mech, both warriors must make Piloting Skill rolls to avoid damage in the event of a fall.) If the primary cockpit slot in a BattleMech or aerospace unit is destroyed, the secondary pilot automatically takes over the unit (though any initiative modifiers provided by the system are lost in the process). If both cockpit slots are destroyed, the unit is considered destroyed per standard gameplay rules for cockpit destruction.

Finally, if the second warrior is the overall commander of a given force (see *Commanders*, p. 191), the force commander’s presence in a Command Console provides a +2 Initiative modifier for the unit’s side as long as the force commander is not the warrior engaged in operating the unit in any way (including moving the unit, making attacks, or making any Piloting Skill Rolls except for those to avoid damage in a fall). To receive this benefit, however, the Command Console unit must be of the heavy or assault weight classes and feature Advanced Fire Control (which is an optional system on non-military units such as IndustrialMechs and Support Vehicles, but is incorporated automatically on all BattleMechs, Combat Vehicles, and Fighters). If, for any reason, the force commander must act as the unit’s pilot or gunner for any reason other than to avoid damage from falling, the Initiative modifier does not apply for the following turn. Command Console Initiative modifiers are not cumulative, even if a force has multiple units with this item.

## SMALL AEROSPACE COCKPIT

**Rules Level:** Advanced

**Available To:** AF

**Tech Base (Ratings):** Inner Sphere (E/X-X-E)

**Game Rules:** An aerospace fighter using a Small Aerospace Cockpit suffers the same +1 Piloting Skill roll target modifier during game play as a Small Cockpit imposes on its MechWarrior equivalent.

## TORSO-MOUNTED COCKPIT

**Rules Level:** Experimental

**Available To:** BM, IM

**Tech Base (Ratings):** Both (E/X-X-F)

**Game Rules:** A MechWarrior using a torso-mounted cockpit receives no pilot damage from hits to the torso area where the cockpit is placed, though ammunition explosions, excess heat, falling damage, and cockpit destruction may affect the warrior as normal. A +1 to-hit modifier applies on all Piloting Skill rolls made by a warrior using a torso-mounted cockpit (due to its cramped space). It is impossible to eject from a torso-mounted cockpit.

Because the torso-mounted cockpit requires additional sensors, a ‘Mech using this system may survive 2 sensor critical hits and still perform weapon attacks. Instead of the standard modifiers from sensor damage, the first sensor hit incurs a +2 to-hit modifier to all weapon attacks, while the second increases this to a +4 modifier. If both sensor hits are in the head, the +4 modifier at the second sensor hit also applies to all Physical Attacks and Piloting Skill rolls, as the ‘Mech is effectively blinded. Three sensor hits (or more) completely blind a ‘Mech with a torso-mounted cockpit, rendering all Weapon Attacks impossible and applying a +4 modifier to all Piloting Skill target numbers.

Finally, because of proximity to the engine, warriors using a torso-mounted cockpit suffer more severe heat effects in the event of life support damage. If a unit with a torso-mounted cockpit takes a life support critical hit, the MechWarrior suffers 1 point of damage for every turn the ‘Mech overheats by 1 to 14 points, and 2 points of damage for every turn the unit overheats by 15 points or more. This MechWarrior heat effect replaces the standard MechWarrior heat effects.

# COLLAPSIBLE COMMAND MODULE (CCM)

**Introduced:** 2710 (Terran Hegemony)

The Collapsible Command Module (CCM) is a detachable section that can be mounted on the torso of a BattleMech. Though used since the Star League era, this item is extremely rare, and most famously used by the HQ

variant of the venerable *Cyclops* BattleMech. The CCM can be dismounted and set up in the field within 15 minutes, establishing a fully operational headquarters bunker, equipped with enough communications and control equipment to coordinate forces up to a full ‘Mech regiment in size.

INTRODUCTION

ADVANCED  
GROUND MOVEMENT

ADVANCED  
COMBAT

ADVANCED  
BUILDINGS

ADVANCED  
SUPPORT  
VEHICLES

GENERAL  
RULES

ADVANCED  
SUPPORT VEHICLE  
CONSTRUCTION

ADVANCED  
WEAPONS  
AND EQUIPMENT

INDEX

RECORD SHEETS

## COLLAPSIBLE COMMAND MODULE (CCM)



**Rules Level:** Experimental

**Available To:** BM, IM

**Tech Base (Ratings):** Both (D/E-F-E)

**Game Rules:** When dismounted, the CCM is treated as a level 1 Heavy building with a CF of 60. It provides the benefits of a Mobile HQ with 7 tons of communications equipment (see p. 212, *TM*).

While being transported by a BattleMech, the CCM cannot be manned or operational. Any damage that strikes the internal structure of the torso in which the CCM is located also applies to the CCM's CF. Each critical hit on the CCM reduces the operational communications equipment by 1 ton (to a minimum of 0).

Detaching or attaching a CCM takes 5 minutes (30 turns in standard *TW* game play), during which time the transporting unit may not move or engage in combat. Setting up a detached CCM requires an additional 15 minutes (90 turns in *TW* game play) and a specialized crew (treated as a 7-man conventional foot "platoon" that must be brought in separately).

## COMBAT VEHICLE CHASSIS MODIFICATIONS

Evolved for the battlefields of the Succession Wars, many conventional vehicles and fighters drew increasingly generalized toward a certain set of standard conditions, which ultimately served to limit their options in terms of

environmental functionality. Amphibious capabilities, dune buggy modifications and environmental sealing against vacuum all became optional features, available to a multitude of units, but not commonly seen on the majority.

### FLOTATION HULL (HOVERCRAFT, VTOLS, WIGES, CONVENTIONAL FIGHTERS)

**Introduced:** Pre-spaceflight

A flotation hull modifies the design of the appropriate unit's hull so it may float on water when unpowered. This feature is particularly useful for ocean-

crossing hovercraft, military vehicles expected to spend a lot of time on the water, carrier-launched conventional fighters and VTOLs.

### FLOTATION HULL (HOVERCRAFT, VTOLS, WIGES, CONVENTIONAL FIGHTERS)



**Rules Level:** Advanced

**Available To:** CV, CF

**Tech Base (Ratings):** Both (B/B-B-B)

**Game Rules:** Units with flotation hull amphibious capability can land on (and take off from) water per their normal rules, as if the water surface is clear terrain. When landed on water, these units are treated as displacement hull naval vessels for purposes of line of sight, hull breaching and sinking rules, and will not sink or be destroyed during water landings unless the armor in one or more non-turret locations is breached.

### LIMITED AMPHIBIOUS (WHEELED AND TRACKED VEHICLES)

**Introduced:** Pre-spaceflight

The "limited capacity" amphibious option enables wheeled and tracked vehicles to cross water deeper than Depth 0, and is generally intended for

river crossings, shallow battlefield water obstructions and to make amphibious assaults from close to shore.

### LIMITED AMPHIBIOUS (WHEELED AND TRACKED VEHICLES)



**Rules Level:** Advanced

**Available To:** CV

**Tech Base (Ratings):** Both (B/B-B-B)

**Game Rules:** A vehicle with the Limited Amphibious capability receives a maximum of 2 MP in water (or the maximum MP of the vehicle, whichever is less). While on water, this MP is always treated as Flanking movement. Moving through water of any depth (including Depth 0) costs Limited Amphibious Vehicles 2 MP per hex. While on water, the vehicle is treated as a displacement hull naval vessel for purposes of line of sight, hull breaching and sinking rules.

**Flotation Hull:** The flotation hull option is only available to Hover, WIGE, and VTOL Combat Vehicles, as well as Conventional Fighters, at no cost in weight or space (though flotation hull designs will increase the unit's final cost).

**Limited Amphibious:** The limited amphibious option is only available to Tracked and Wheeled Combat Vehicles, weighs 1 ton per 25 tons of total unit weight (rounded up to the nearest 0.5 tons) and takes up no space in vehicle design.

**Fully Amphibious:** The fully amphibious option is only available to Tracked and Wheeled Combat Vehicles. It weighs 1 ton per 10 tons of total unit weight (rounded up to the nearest 0.5 tons) and takes up no space in vehicle design.

**Dune Buggy:** The dune buggy modification is only available to Wheeled Combat Vehicles, at no cost in weight or space (though dune buggy modifications will increase a unit's final cost).

**Environmental (Vacuum) Sealing:** See p. 216, *TM*. Environmental sealing is automatically featured on Combat Vehicles built as submarines (as well as BattleMechs, ProtoMechs, fighters, Small Craft and Large Craft). The sealing equipment weighs 10 percent (rounded up to the nearest half ton) of the unit's total weight and occupies no weapon or item slots.

## FULLY AMPHIBIOUS (WHEELED AND TRACKED VEHICLES)

**Introduced:** Pre-spaceflight

The “full capability” amphibious option for wheeled and tracked vehicles is heavier, but provides a much faster means of getting vehicles across bod-

ies of water. This feature is rare on combat vehicles, and intended for “over the horizon” amphibious assaults.

### FULLY AMPHIBIOUS (WHEELED AND TRACKED VEHICLES)

**Rules Level:** Advanced

**Available To:** CV

**Tech Base (Ratings):** Both (B/B-B-B)

**Game Rules:** A vehicle with fully amphibious capabilities has the same MPs on water (both Cruising and Flanking) as it does on land. However, each water hex (of any depth, including Depth 0) costs 2 MP to cross. While on water, the amphibious vehicle is treated as a displacement hull naval vessel for purposes of line of sight, hull breaching and sinking rules.

## DUNE BUGGY MODIFICATION (WHEELED VEHICLES)

**Introduced:** Pre-spaceflight

The dune buggy modification enhances a combat vehicle’s standard motive systems with larger wheels and a higher suspension able to cope with the shifting, sandy terrain of most beaches and deserts. Rare on combat

vehicles because it overspecializes the unit and can impair performance in other areas, dune buggy-modified combat vehicles nonetheless have found a home in many combat zones.

### DUNE BUGGY MODIFICATION (WHEELED VEHICLES)

**Rules Level:** Advanced

**Available To:** CV

**Tech Base (Ratings):** Both (B/B-B-B)

**Game Rules:** Dune buggy-modified Combat Vehicles disregard the extra MP cost for sand applied to wheeled Combat Vehicles and instead move through sand terrain (see p. 39) at a cost of 1 MP per hex. However, the modifications to said vehicles costs 1 Cruising MP in overall performance (with Flanking MP recalculated as normal).

## ENVIRONMENTAL (VACUUM) SEALING (COMBAT VEHICLES)

**Introduced:** Pre-spaceflight

Most ground-based Combat Vehicles may be modified for vacuum fairly easily, though to perform in such environs these vehicles require fuel cell, fission or fusion engines for power. Because these modifications are so

extensive and costly in terms of weight, environmentally sealed (or vacuum-sealed) units are a relative rarity on the battlefield, leaving most combat in the absence of breathable air to BattleMechs and fighters.

### ENVIRONMENTAL (VACUUM) SEALING (COMBAT VEHICLES)

**Rules Level:** Advanced

**Available To:** CV

**Tech Base (Ratings):** Both (B/C-D-C)

**Game Rules:** All Combat Vehicles with the Environmental (Vacuum) Sealing modification operate normally in toxic or tainted atmospheres, and may even function in vacuum if fitted with a fission, fusion or fuel cell engine. However, this benefit is lost (and the unit is destroyed) if all armor in any location is destroyed, or if the unit suffers a hull integrity breach when taking damage. This hull integrity check is made any time the unit suffers damage, with a breach occurring on a 2D6 roll result of 10 or higher.

## COOLANT POD

**R&D Start Date:** 3041 (Federated Commonwealth), 3055 (Clan Jade Falcon)

**Prototype Design and Production:** 3049 (Federated Commonwealth), 3056 (Clan Steel Viper)

An outgrowth of double heat sink development in the 3040s, research into more efficient pumps and cooling fluids for combat-grade heat exchange systems has occupied many Inner Sphere (and Clan) scientists over

the past few decades. One promising prototype—seen in use by Clan and Inner Sphere engineers—is a specialized high-pressure, one-shot system. While these so-called coolant pods remain unsuitable for a full-scale heat exchange system (as many of the chemicals used are highly corrosive and the high-pressure system poses and explosive risk), they have gained a niche in the Solaris arenas as an emergency cooling system.

INTRODUCTION

ADVANCED  
GROUND MOVEMENT

ADVANCED  
COMBAT

ADVANCED  
BUILDINGS

ADVANCED  
SUPPORT  
VEHICLES

GENERAL  
RULES

ADVANCED  
SUPPORT VEHICLE  
CONSTRUCTION

ADVANCED  
WEAPONS  
AND EQUIPMENT

INDEX

RECORD SHEETS



## COOLANT POD



**Rules Level:** Experimental

**Available To:** BM, IM, AF, CF

**Tech Base (Ratings):** Both (D/X-X-E)

**Game Rules:** Though a unit may mount multiple Coolant Pods, only one may be triggered per turn, which is done at the start of the unit's Heat Phase. A Coolant Pod increases the cooling capacity of all of the unit's active heat sinks by 1 point each (regardless of heat sink type). If a critical hit strikes a Coolant Pod, the compressed fluids explode for 10 points of damage, as an internal ammo explosion.

## DISPOSABLE WEAPONS

**Introduced:** Pre-spaceflight

In addition to their standard primary and secondary weapons, many infantry troopers in the 31st century have gone into battle equipped with

single, one-shot disposable weapons such as LAWs. Used properly, these weapons can provide a platoon or squad with a brief boost in firepower, perhaps even enough to breach a tough opponent such as a BattleMech.



## DISPOSABLE WEAPONS



**Rules Level:** Advanced

**Available To:** CI, BA

**Tech Base (Ratings):** Both (see *TechManual* cost and equipment tables)

**Game Rules:** Once per scenario, the platoon or battle armor squad may make a single attack using these Disposable Weapons (instead of the platoon's standard weapon attack) so long as the infantry unit is not engaged in an anti-Mech attack. This attack is treated as a standard direct-fire attack, using the range brackets of the Disposable Weapons only.

If the attack succeeds, resolve the damage per a standard infantry ranged attack based on the number of active troopers in the platoon and the damage value of the disposable weapons (see pp. 214-215, *TW*). The total damage inflicted equals the disposable weapon's damage value times the number of troopers who hit using the Cluster Hits Table, rounded normally (.5 rounds up). This damage is applied to the target per a normal conventional infantry weapon attack.

## DOCKING HARDPOINT (DOCKING COLLAR)

**Introduced:** Early spaceflight

A necessity in most large spacecraft, docking collars are large, reinforced couplers combined with airlocks and hatches large enough to facilitate the movement of personnel and cargo between two connected spacecraft. Not to be confused with simple personnel airlocks used for EVA work or

emergency escape, modern docking hardpoints are primarily used to secure DropShips to the outer hull of a JumpShip or WarShip. Thus, these collars incorporate an interface mechanism that extends the jump-capable craft's Kearny-Fuchida field around the docked vessel. This enables both ships to traverse hyperspace safely.



## DOCKING HARDPOINT (DOCKING COLLAR)



**Rules Level:** Advanced

**Available To:** JS, SS, WS, MS

**Tech Base (Ratings):** Both (B/C-C-C)

**Game Rules:** A vessel with a docking hardpoint (also known as a docking collar) can use the Docking rules also covered in *Strategic Operations*. Mobile Structures with a Landing Deck may also employ a docking hardpoint to secure landed vessels and use the cargo transfer rules also covered in *Strategic Operations*.

**Coolant Pod:** The Coolant Pod may be mounted on any available unit in accordance with the unit's standard construction rules.

**Disposable Weapons:** Any Conventional Infantry unit may be equipped with a single one-shot Disposable Weapon per active trooper. Battle armor suits may only carry Disposable Weapons if they are also equipped with an anti-personnel weapon mount (with sufficient weight capacity) or two armored gloves. To make use of Disposable Weapons, all troopers in a platoon (or battle armor squad) must have the same Disposable Infantry Weapons. Applicable weapons are noted on the *TechManual* infantry weapons table with an Ammo (Shots) listing of (1-D).

**Docking Hardpoint (Docking Collar):** Each docking hardpoint weighs 1,000 tons and is available only to JumpShips, WarShips, Space Stations, and Mobile Structures with a Landing Deck. Appropriate aerospace units may mount up to 1 docking hardpoint for every 50,000 tons of vessel weight (rounded down). Mobile Structures may mount only one Docking Collar per Landing Deck. Docking Collars are not counted as weapon items and do not require a location.

**Docking Thrusters:** Only Large-size Naval Vessels can use this equipment. Only one set of Docking Thrusters may be installed per unit.

**Drone Carrier Control System:** The Carrier Control System for remote drones weighs 2 tons, plus 0.5 tons per controlled drone unit. This tonnage includes the crew accommodations for each drone's operator (1 per drone), as well as the carrier unit's requisite drone-control sensor package. A carrier unit may install multiple Carrier Control Systems, per the unit's standard construction rules.

# DOCKING THRUSTERS

**Introduced:** Pre-spaceflight

A modification common on larger naval vessels to assist in close-quarters maneuvering (such as during docking operations at the typical seaport), docking thrusters are an extensive series of maneuvering propellers or un-

derwater “jets” located along the bow and aft of large vessels and inactive during normal operations. When the vessel is not operating at speed, these systems may be used to spin the vessel in place or even sideslip it into a tight berth.

## DOCKING THRUSTERS

**Rules Level:** Advanced

**Available To:** SV

**Tech Base (Ratings):** Both (B/C-C-C)

**Game Rules:** Docking Thrusters may be used to allow any Large-size Naval Vehicle that is otherwise stationary (that is, expending no MPs on forward or reverse movement in the current turn) to pivot in place or move laterally, in exception to the standard rules for Large Naval Vessel movement (see p. 154). The maximum number of MPs that can be expended using Docking Thrusters equals the vessel's Cruising MP.

Pivoting in place costs a Docking Thruster-equipped vessel 3 MP per hexside of facing change, with the vessel pivoting around its template's pivot point. Lateral movement using Docking Thrusters costs 4 MP per hex of movement, which shifts the entire vessel sideways by 1 hex (with the pivot point moving to any desired adjacent hex except for those directly forward or backward).

Large-size Naval Vessels attempting either maneuver may spend MPs on no other movement type when using Docking Thrusters in this fashion. Also, should a vessel lack sufficient Cruising MPs to complete such maneuvers in a single turn, it may “bank” any remaining Cruising MPs to complete the maneuver in the following turn, executing the full maneuver only in the turn where the accumulated points meet the maneuvering requirements. For example, a Large-size Naval Vessel with a Cruising MP of 3 attempting to make a lateral movement would require 2 turns to execute the maneuver, shifting its position on the map only in the second turn, when the maneuver is completed.

# DRONE (REMOTE) SYSTEMS

**Introduced:** Early spaceflight

Not to be confused with the fully autonomous robotic control systems used by the infamous *Caspar*-class drones of the Star League era, the drone control systems used in the 31st century instead reflect a less sophisticated remote-control command and operating system, where human hands

direct the intelligence of unmanned vehicles. Because of their reliance on communications, remote drone systems are highly susceptible to ECM, and they are often far less effective than piloted machines. These factors alone have prevented remote drone control and operating systems from becoming commonplace on the battlefield.

## DRONE (REMOTE) CARRIER CONTROL SYSTEM

**Rules Level:** Advanced

**Available To:** CV, SV, SC, JS, DS, SS, WS, MS

**Tech Base (Ratings):** Both (C/E-F-F)

**Game Rules:** To operate any remote drone network, a dedicated carrier control system must be present, functional and free from interference. Drone networks of any available vehicle type can be controlled by any friendly carrier control system (also of any available vehicle type). However, ground-based networks (without satellite aid) have a maximum functional radius of 80 kilometers (about 160 *Classic BattleTech* mapsheets) before ground clutter and background interference renders them incoherent. Aerospace-based carrier control systems (including satellite-based systems) that maintain an unbroken line of sight have a much longer range at 3 million kilometers (after which communications lag makes any drones far less responsive to control).

A drone control unit and all of its attached drones are treated as a single unit for Initiative purposes. Drone control units automatically detect any units detectable by the drones they control (including hidden units adjacent to the drones or within range of drone-based active probes), but must adhere to standard rules for determining line of sight to attack such units. Drones can be used as LRM indirect fire spotters (see p. 111, *TW*). However, when used in such a fashion, the movement modifier for the drone control unit (as well as that of the spotting drone) must also be applied to the attacker's to-hit roll. Furthermore, the +1 modifier for the spotting unit making attacks also applies if the drone control unit makes its own attacks in the same turn (a +2 modifier applies if *both* the spotting drone and the drone control unit make attacks in the same turn as they are used to spot for indirect fire).

All hostile ECM (including Guardian, Angel and Watchdog systems, screen launchers and chaff) disrupts the signal between drone carriers and their drones if they occur in the line of sight between them. If an ECM bubble includes the carrier control unit, all drones in the carrier's network are affected. Otherwise, the bubble only disrupts the operations of the drones to which it blocks the carrier's LOS. Critical hits that affect the sensors of a unit with a carrier control system (or the carrier control system itself) also disable the drone control network. Critical hits that result in a Crew Stunned, Crew Killed or Commander Hit effect on a unit using a drone carrier control system also disable the network. For as long as these effects last, the drone control unit will be unable to communicate with the drones.

Drones suffering from communications failure (either due to damage or the interference as described above) simply cease operations and become immobile targets on the ground (or continue to coast along their last known velocity, vector and facing in space. Airborne drones in the space/atmosphere interface, atmospheric row or ground row hexes of the High-Altitude Map fall 1 hex per turn of communications failure, starting during the Movement Phase (Aerospace) on the turn following the turn communication fails. If there are two equal hexes to fall into, randomly determine which hex the unit enters. If players are using Low-Altitude Movement, the airborne drone falls three altitudes each turn. If it enters a Ground Hex (on the High-Altitude Map) or Altitude 0 (if using Low-Altitude Movement), the airborne drone crashes. If communications are later reestablished—before the carrier control unit or its drones are destroyed—the drones may resume operating normally.

INTRODUCTION

ADVANCED  
GROUND MOVEMENT

ADVANCED  
COMBAT

ADVANCED  
BUILDINGS

ADVANCED  
SUPPORT  
VEHICLES

GENERAL  
RULES

ADVANCED  
SUPPORT VEHICLE  
CONSTRUCTION

ADVANCED  
WEAPONS  
AND EQUIPMENT

INDEX

RECORD SHEETS

## DRONE (REMOTE) OPERATING SYSTEMS

**Rules Level:** Advanced

**Available To:** BM, IM, CV, SV, AF, CF

**Tech Base (Ratings):** Both (C/E-F-F)

**Game Rules:** Vehicles using a remote drone operating system are automatically considered to have a Crew of 0 for game play purposes, regardless of the construction rules for said unit, and may not use crew-served equipment beyond weapons, communications and sensors. Any Piloting or Gunnery Skill checks made by drone vehicles suffer a +1 modifier (based on the skills of the carrier control unit).

Critical hits against remote drone vehicles that would normally stun or kill a driver or crew do not affect drones (as they have no crew), but all hits to the vehicle commander destroy the drone's remote operating system, rendering the unit inactive and immobile for the remainder of the game. Also, because they lack a crew, remote drone units may not clear weapon or turret jams in combat.

If for any reason (noted above under the drone carrier control system rules) a drone is cut off from its network controller, the drone becomes inactive and immobile. Airborne drones in the space/atmosphere interface, atmospheric row or ground row hexes of the High-Altitude Map fall 1 hex per turn of communications failure, starting during the Movement Phase (Aerospace) on the turn following the turn communication fails. If there are two equal hexes to fall into, randomly determine which hex the unit enters. If players are using Low-Altitude Movement, the airborne drone falls three altitudes each turn. If it enters a Ground Hex (on the High-Altitude Map) or Altitude 0 (if using Low-Altitude Movement), the airborne drone crashes. Drones operating in space under these conditions continue along their last heading and speed, expending no Thrust and making no actions. If communications with the control unit are restored at some point (and the drones are not destroyed in the meantime), any drones affected by such network failures resume normal operation.

## ENERGY STORAGE BATTERIES

**Introduced:** 2131 (Terran Alliance)

The key element of recharge stations, these large power generation, storage and distribution systems (generically referred to as energy storage batteries, though they usually include power plants) enable Kearny-Fuchida drive vessels to recharge relatively quickly and safely, without the headache

of deploying their huge (and delicate) solar sails. They are particularly useful at small, dim stars where K-F drive recharge times can stretch to ten days or more, and even more useful for vessels with lithium-fusion batteries; energy storage batteries can vastly reduce the travel time needed for JumpShips in a hurry.

## ENERGY STORAGE BATTERIES

**Rules Level:** Advanced

**Available To:** SS

**Tech Base (Ratings):** Both (D/C-E-D)

**Game Rules:** Energy Storage Batteries are an alternative to conventional K-F drive recharge sources (including JumpShip solar sails and fusion engines), but can charge a vessel's K-F drive either through its jump sail (typically via a diffuse microwave beam) or by a direct connection (requiring the vessel to dock with the recharging station).

When an Energy Storage Battery's power is delivered via the vessel's solar sail, normal quick charging rules are followed, the rules of which are found in *Strategic Operations*.

If the vessel instead uses a direct connection to the charging station, the Energy Storage Battery applies a -2 modifier to rolls made on the Quick-Charge Table (to a minimum of 2), allowing for relatively safe quick-charges.

Energy Storage Batteries include massive power plants that can recharge their storage systems about as fast as they can be safely discharged into a JumpShip. An Energy Storage Battery can thus prepare a new charge for a JumpShip in 100 hours (which can occur concurrently while recharging a K-F drive). Full rules on constructing space stations will appear in *Strategic Operations*.

**Drone Operating System:** Remote drone operating systems occupy 10 percent of the drone unit's total weight and are treated as a single item on the unit's equipment list (located in the body). An additional half-ton sensor system is required as well, reflecting the drone's communications interface. A vehicle using a remote drone operating system is always considered to have a Crew of 0 for construction purposes (regardless of its normal needs under the vehicle's construction rules).

**Energy Storage Batteries:** Energy Storage Batteries are limited to Space Stations, which can mount any number of batteries desired in accordance with the unit's standard construction rules.

**Combat Vehicle Fission Engines:** Available units designed to employ fission engines determine their ratings as normal for the unit's type. To find a fission engine's weight, use the Fission column on the Master Engine Table (see p. 49, *TM*). As with fusion engines, Combat Vehicles must devote an additional 50 percent of the engine's weight into their designs to reflect engine shielding for the crew's benefit. Combat Vehicle Fission Engines also provide a certain number of "weight-free" heat sinks, as noted under the "Free Sinks" column. Combat Vehicles using fission engines do not require power amplifiers for using energy weapons (though heat sinks to fire such weapons are still required, per the normal Combat vehicle construction rules).

**Combat Vehicle Fuel Cell Engines:** These engines have their ratings determined as normal for their unit type. To determine engine weight, use the Cell column on the Master Engine Table (see p. 49, *TM*). Combat Vehicle Fuel Cell Engines also provide a single "weight-free" heat sink, as noted under the "Free Sinks" column. Combat Vehicles using fuel cell engines still require power amplifiers for using energy weapons (and heat sinks to fire such weapons are still required, per the normal Combat vehicle construction rules).

# ENGINE SYSTEMS

A number of alternative power systems for combat vehicles (including BattleMechs and fighters) have been under development ever since the technological renaissance of the mid-3020s. However, it was not until the

Clan invasion that the Inner Sphere and the Clans both looked seriously at the notion of expanded combat engine options, in a desperate bid to gain and maintain any battlefield edge.

## COMBAT VEHICLE FISSION (CV-FISSION)

**Introduced:** 2882 (Taurian Concordat)

Though theoretically feasible for over a millennium, fission engines have long been rare in small-scale combat vehicle design. The widespread aversion to all things nuclear prevented their use during the twentieth and early twenty-first centuries, while the safer and more plentiful use of fusion engines kept them in the shadows through the Age of War and Star League eras. Only the gradual decline in high tech industries during the Succession Wars brought fission-powered sources back from the grave—if only to a limited extent.

Nonetheless, fission engines for combat vehicles remained hypothetically feasible. During the Succession Wars, some major Periphery powers (notably the Taurian Concordat) explored fission power as a battlefield alternative to fusion, one ideally within the capabilities of local industry. Though exotic and somewhat more dangerous than equivalent fusion plants (not to mention too inefficient for use in most aerospace vehicles), fission-based combat engines can be found today dispersed around the Periphery and Inner Sphere, distributed by the vagaries of war and mercenary wanderings.

## COMBAT VEHICLE FISSION (CV-FISSION)

**Rules Level:** Advanced

**Available To:** BM, CV, CF

**Tech Base (Ratings):** Inner Sphere (D/F-E-E)

**Game Rules:** On BattleMechs and conventional Combat Vehicles, fission engines follow the same rules as IndustrialMech fission engines (see p. 126, *TW*). Conventional Fighters powered by fission engines follow the normal fighter engine critical hit rules (see p. 240, *TW*), but receive 160 points per ton of fuel.

## COMBAT VEHICLE FUEL CELL (CV-CELL)

**Introduced:** 2046 (Western Alliance)

Though widely used in civilian applications for centuries, the pre-Succession War dominance of fusion engines largely kept fuel cells out of military vehicles. Similarly, the centuries of accumulated inertia behind

military IC engines discouraged the use of fuel cells during the Succession Wars. However, engine manufacturers throughout the centuries quietly maintained the option to employ battlefield-grade fuel cells for military customers on request.

## COMBAT VEHICLE FUEL CELL (CV-CELL)

**Rules Level:** Advanced

**Available To:** BM, CV

**Tech Base (Ratings):** Both (D/C-C-C)

**Game Rules:** BattleMechs with fuel cell engines follow the same rules as IndustrialMechs with fuel cell engines (see p. 126, *TW*). Both BattleMechs and Combat Vehicles using fuel cell engines also follow the IndustrialMech fuel consumption rules (see p. 68, *TM*).

## LARGE ENGINE (LIC, LLF, LSF, LXL, LXXL)

**R&D Start Date:** circa 2550 (Terran Hegemony)

**Prototype Design and Production:** circa 2630 (Terran Hegemony)

The diminishing returns found in combat engines of all types over the centuries led Star League engineers to abandon the development of engines rated beyond the universal power rating of 400 some time during the early 2600s. Since then, conventional wisdom has maintained that combat engines rated over 300 to 360 push the acceptable boundaries of

cost-effectiveness and power efficiency—and that viable engines beyond the 400 mark are downright ludicrous. However, real-world engineers have occasionally explored customized combat-grade engines with ratings over 400 (and as high as 500). Unfortunately, these so-called large engines—feasible in internal combustion and fusion varieties alike—are incredibly massive, which has kept them from standard production even though they remain technically possible.

## LARGE ENGINE (LIC, LLF, LSF, LXL, LXXL)

**Rules Level:** Experimental

**Available To:** BM, IM, CV, AF, CF

**Tech Base (Ratings):** Both (per base engine availability)

**Game Rules:** In game play, all Large Combat Engines function in the same fashion as their smaller equivalents. Though Combat Vehicle and Conventional Fighter engines may occupy weapon slots, such engines only suffer critical hits per the unit's standard rules.

INTRODUCTION

ADVANCED  
GROUND MOVEMENT

ADVANCED  
COMBAT

ADVANCED  
BUILDINGS

ADVANCED  
SUPPORT  
VEHICLES

GENERAL  
RULES

ADVANCED  
SUPPORT VEHICLE  
CONSTRUCTION

ADVANCED  
WEAPONS  
AND EQUIPMENT

INDEX

RECORD SHEETS

**Large Engines:** The weight and required space requirements (for 'Mechs and Vehicles/Conventional Fighters) of each available type of Large Engine are indicated in the Advanced Fusion Engine Table below. Large Engines are available in internal combustion (ICE), light fusion, standard fusion, XL fusion and even XXL fusion types (but not as fuel cell, fission or compact fusion). Combat Vehicles require additional engine shielding for all Large-sized fusion engines, which weighs an additional 50 percent of the engine's weight. Combat Vehicles and Conventional Fighters using Large Engine types may also require that such engines take up weapon/item slots, as indicated in the Advanced Engine Master Table.

Large Engines of any fusion type also provide 10 "weight-free" heat sinks, as noted under the "Free Sinks" column. Combat Vehicles using these engines do not require power amplifiers for using energy weapons (though heat sinks to fire such weapons are still required, per the normal Combat Vehicle construction rules).

**XXL Fusion Engines:** An XXL Engine weighs one-third as much as its standard counterpart, but takes up twice as many critical slots in the side torsos as an XL (4 each for Clan technology, 6 each for Inner Sphere technology). XXL Engines are also extremely expensive, costing 5 times as much as a standard XL engine (see the Combined Engines Table). Combat Vehicles require additional engine shielding for all fusion engines, which weighs an additional 50 percent of the engine's weight. Combat Vehicles and Conventional Fighters using XXL fusion engines also require that such engines take up weapon/item slots, as indicated in the Advanced Engine Master Table below.

XXL Engines also provide 10 "weight-free" heat sinks, as noted under the "Free Sinks" column. Combat Vehicles using these engines do not require power amplifiers for using energy weapons (but do require heat sinks to fire such weapons, per the normal Combat Vehicle construction rules).

## ADVANCED ENGINE MASTER TABLE

Engine Type	Mass (Tons)	Additional Item Slots			Large Engine Weight					
		'Mech*	Vehicle/Fighter*	Free Sinks	Engine Rating	ICE	Std.**	Light**	XL**	XXL**
CV-Fission	†	†	0	5	405	113.0	56.5	42.5	28.5	19.0
CV-Fuel Cell	†	†	0	1	410	122.0	61.0	46.0	30.5	20.5
Large-ICE	‡	2 (CT)	1	0	415	133.0	66.5	50.0	33.5	22.5
Large-Fusion	‡	2 (CT)	1	10	420	145.0	72.5	54.5	36.5	24.5
Large-Light	‡	2 (CT), 2 (ST)‡	2	10	425	159.0	79.5	60.0	40.0	26.5
Large-XL (IS)	‡	2 (CT), 3 (ST)‡	3	10	430	175.0	87.5	66.0	44.0	29.5
Large-XL (Clan)	‡	2 (CT), 2 (ST)‡	2	10	435	194.0	97.0	73.0	48.5	32.5
Large-XXL (IS)	‡	2 (CT), 6 (ST)‡	5	10	440	215.0	107.5	81.0	54.0	36.0
Large-XXL (Clan)	‡	2 (CT), 4 (ST)‡	3	10	445	239.0	119.5	90.0	60.0	40.0
Compact Fusion	†	†	0	10	450	267.0	133.5	100.5	67.0	44.5
Light Fusion	†	†	1	10	455	300.0	150.0	112.5	75.0	50.0
XL Fusion (IS)	†	†	2	10	460	337.0	168.5	126.5	84.5	56.5
XL Fusion (Clan)	†	†	1	10	465	380.0	190.0	142.5	95.0	63.5
XXL Fusion (IS)	x0.333†	6 (ST)	4	10	470	429.0	214.5	161.0	107.5	71.5
XXL Fusion (Clan)	x0.333†	4 (ST)	2	10	475	486.0	243.0	182.5	121.5	81.0
					480	551.0	275.5	207.0	138.0	92.0
					485	626.0	313.0	235.0	156.5	104.5
					490	712.0	356.0	267.0	178.0	119.0
					495	811.0	405.5	304.5	203.0	135.5
					500	925.0	462.5	347.0	231.5	154.5

\*For 'Mechs, CT = Center Torso; ST = Side Torsos (applies to left and right side locations). All Vehicle slots are allocated to the body; Fighter slots (if applicable) are located in the rear, with any extras divided evenly among the side wings.

\*\*These Engine Types are fusion-based.

†Per standard construction rules (see *TechManual*); XXL engine multiply the weight of a standard fusion engine by the value shown (rounded up to the nearest half ton)

‡See Large Engine Weight Table

**Combat Vehicle Escape Pod:** Combat Vehicles of any type may mount a maximum of 1 CVEP, which must be placed in the vehicle's rear location.

## XXL FUSION ENGINE

**R&D Start Date:** 2582 (Terran Hegemony)

**Prototype Design and Production:** 2954 (Clan Diamond Shark),  
3055 (Federated Commonwealth)

As soon as Star League engineers brought extra-light fusion technology to life, researchers began wondering if it was possible to reduce a fusion engine's weight by more than half. Though the Terran Hegemony ultimately shelved the project in favor of others deemed more useful, both Inner Sphere and Clan scientists tackled this same concept centuries later. Though

they followed different approaches (improved shielding, ultralight containment field electromagnets and so on), both sides came up with roughly the same result. Dubbed Extra-Extralight (XXL) fusion engines, these power plants promised the same capabilities at one-third of the standard mass (and easily twenty times the price). Unfortunately, the extremely bulky and hot-running engines quickly proved better suited for physics laboratories than the battlefield.

### XXL FUSION ENGINE

**Rules Level:** Experimental

**Available To:** BM, CV, AF, CF

**Tech Base (Ratings):** Both (F/X-X-F)

**Game Rules:** In game play, XXL fusion engines run hotter than their other fusion equivalents. Standing still (or expending no Thrust) generates 2 heat points per turn, Walking/Safe Thrust movement generates 4 heat points, and Running/Max Thrust movement generates 6 heat points. Heat generated by jumping is doubled for XXL engine users, costing 2 heat points per hex jumped, with a minimum of 6 points per jump. (Combat Vehicles using XXL engines do not have to track movement heat, as per the standard Combat Vehicle rules.) Though Combat Vehicle and Conventional Fighter engines may occupy weapon slots, such engines only suffer critical hits per the unit's standard rules.

## EJECTION SYSTEMS

Though BattleMechs, fighters and many other combat units feature or have access to emergency egress systems, the past century has seen a few new developments in emergency ejection systems designed to enhance the survivability of warriors in hostile environments. Two of the most effective

are the Combat Vehicle escape pod and the BattleMech full-head ejection system. Though both are expensive and somewhat risky, these ejection mechanisms nonetheless promise survivability that standard egress systems may not, at least under select circumstances.

### COMBAT VEHICLE ESCAPE POD

**R&D Start Date:** 3032 (Federated Commonwealth)

**Prototype Design and Production:** 3038 (Federated Commonwealth)

A radical concept in Combat Vehicle escape systems, the Combat Vehicle Escape Pod (CVEP) is a cramped, self-sealing mini-cabin built into a vehicle's rear quarter and used to escape certain destruction in hostile atmospheres. Though it is modeled on the design of the Lyran Commonwealth's revolutionary full-head ejection system for BattleMechs, the compartmentalized design and segregated control stations of most Combat Vehicles negates

much of its value by forcing the vehicle crew to decide on their own when the time has come to employ the emergency egress system, rather than auto-ejecting them to safety in the event of catastrophe. This single flaw has effectively prevented the CVEP from entering full-scale production.

### COMBAT VEHICLE ESCAPE POD

**Rules Level:** Experimental

**Available To:** CV

**Tech Base (Ratings):** Inner Sphere (D/X-X-E)

**Game Rules:** Only Combat Vehicles may mount a CVEP, which is treated as a weapon item in the rear and may thus be damaged by any weapon critical hits to that location. During the Movement Phase of any turn, the crew of a Combat Vehicle may choose to use the CVEP to escape their vehicle, so long as the system has not been previously damaged. Once launched, the crew makes a Piloting Skill roll with a +2 target modifier. If successful, the pod travels up to 4 hexes (at the controlling players' choice) directly behind the vehicle, where a standard MechWarrior Ejection roll (see p. 196) with a +2 modifier is required to see if the pod lands safely. A failure on either the launching roll or the landing roll indicates that the ejected crew suffers physical damage from the violent escape, with each failure resulting in a hit to one crewman (determined randomly). Once the pod lands, the crew may step out and make for safety as a conventional foot infantry unit (with a size equal to the surviving crewmen), or—if landed on water or in an otherwise toxic environment—remain in the capsule to await rescue.

Attacks against a jettisoned CVEP may be made as if targeting an immobile unit, in which case the CVEP is considered breached (and its occupants—if any—killed) after sustaining more than 2 points of damage. Once a CVEP is jettisoned (whether successfully or not), the vehicle is considered to have suffered a Crew Killed result and is treated as destroyed for the remainder of the scenario.

Jettisoned CVEPs may not be salvaged and reinstalled once deployed.

INTRODUCTION

ADVANCED  
GROUND MOVEMENT

ADVANCED  
COMBAT

ADVANCED  
BUILDINGS

ADVANCED  
SUPPORT  
VEHICLES

GENERAL  
RULES

ADVANCED  
SUPPORT VEHICLE  
CONSTRUCTION

ADVANCED  
WEAPONS  
AND EQUIPMENT

INDEX

RECORD SHEETS

## BATTLEMECH FULL-HEAD EJECTION SYSTEM

**Introduced:** 3023 (Lyran Commonwealth), 3052 (Clan Wolf)

Debuting with the Lyran Commonwealth's HCT-3F *Hatchetman*, the BattleMech full-head ejection system enables a MechWarrior to blast well clear of his doomed machine in a fully enclosed pod that literally transforms the entire head assembly into a short-range jump glider. Though a violent

means of escape, the system is ideal for hostile environment combat, particularly underwater, in vacuum or even in the thick of a massive enemy overrun. Only the dramatic expense and the higher-than-average injury rate for warriors using this system have prevented its wider use, though a handful of recent designs have taken to this revolutionary egress system.

## BATTLEMECH FULL-HEAD EJECTION SYSTEM

**Rules Level:** Advanced

**Available To:** BM, IM

**Tech Base (Ratings):** Both (D/X-X-E)

**Game Rules:** Only BattleMechs and IndustrialMechs with head-mounted cockpits may mount a full-head ejection system. Unlike the vehicular model, this system is integrated with the head assembly's design, and so occupies no additional critical slots. However, any critical hits to the 'Mech's Life Support slots also disable this system, rendering it impossible to eject in the event of disaster.

Because the full-head ejection system incorporates the unit's entire control system, this system may be deployed at any phase of a turn at the player's choosing, or may jettison automatically in the event of an internal explosion. However, because the force of the launch is so extreme, the MechWarrior automatically suffers 1 point of damage when the system is launched.

If the 'Mech (or at least its head) is not submerged, the warrior may then choose any hex within 12 hexes of the 'Mech (if the unit was upright at the time), or within 12 hexes in the 'Mech's forward arc (if it was prone) to make landfall. A Piloting Skill roll (with a +3 modifier) is required to make this landing on target or the head will scatter  $1D6 \div 2$  hexes (round down) in a random direction. Upon landing, a standard MechWarrior Ejection roll (see p. 196) must be made with an additional target modifier of +2 to avoid taking a second point of damage from the ejection.

If the 'Mech is submerged (and the head location has suffered no armor breach), an ejected full-head pod automatically rockets to the water's surface and floats there as an immobile displacement hull vessel with the armor and structure values of whatever remained on the 'Mech's head location. A 'Mech with a submerged head that has suffered a breach cannot employ a full-head ejection system.

Once the pod lands (or surfaces), the warrior may step out and make for safety as a conventional foot infantry unit (with a size of 1), or—if landed on water or in an otherwise toxic environment—remain in the capsule to await rescue.

Because ejection can take place during any combat phase, attacks against a jettisoned full-head pod can only be made after it has landed. In this case, the attack receives a -4 to-hit modifier for targeting an immobile unit. Attacks against a jettisoned head inflict damage to the head's remaining armor, internal structure and critical hit locations per any other attack that strikes a BattleMech's head. Once a full-head ejection system is jettisoned (whether successfully or not), the 'Mech is considered to have suffered a Head Blown Off effect and is treated as destroyed for the remainder of the scenario.

An ejected head module may be salvaged later and reattached to the 'Mech (or jury-rigged to another 'Mech) after the scenario.

## ELECTRONIC WARFARE (EW) EQUIPMENT

**Introduced:** 3025 (Capellan Confederation)

An effort by the Capellan Confederation to replicate the lost capabilities of the Star League-era Beagle Active Probe and Guardian ECM suite, the basic electronic warfare equipment package debuted on their RVN-1X

*Raven* BattleMech in 3025. The technology was a landmark in Succession Wars-era development but is largely overlooked today because of the recovery twenty years later of the lighter, more compact and more effective Star League systems it crudely aped.

**Full-Head Ejection System:** BattleMechs and IndustrialMechs may mount a maximum of 1 Full-Head Ejection System, which is automatically assigned to the head location. Though the system takes up no tonnage and occupies no critical slots, the launch mechanisms are integrated with the 'Mech's Life Support System. The ejection system is incompatible with torso-mounted cockpits and Cockpit Command Modules.

**Electronic Warfare (EW) Equipment:** The EW Equipment package may be mounted on any available unit type in accordance with the unit's standard construction rules. The EW Equipment system cannot be used as a substitute for the Guardian ECM on units using Stealth Armor.

**Field Guns:** Any vehicular-scale autocannon (including light, standard, Ultra, LB-X, rotary, and ProtoMech), Gauss weapon (*excluding* heavy and Hyper-Assault types), or Rifle (Cannon, see p. 338) may be used as a Field Gun and can be towed by any motorized or wheeled/tracked mechanized conventional infantry platoon. Field Guns are added after the rest of platoon creation, but as many Field Guns may be added as the platoon has crew to operate (the crew for a single Field Gun equals the weapons tonnage, not counting ammunition). All Field Guns assigned to a platoon must be of the same type and size.

The weight of all Field Guns and their ammunition are added to the platoon's transport weight, and a platoon may not be broken down for transport purposes below the weight of a single Field Gun and its ammunition.

**Field Artillery:** Field Artillery weapons may include any standard artillery weapon (Sniper, Thumper or Long Tom), Arrow IV artillery piece, or Artillery Cannon (see p. 285). A Field Artillery weapon is added after the rest of platoon creation, but requires a minimum platoon size equal to the weapon's weight in tons (not counting ammunition). The weight of a Field Artillery weapon and its ammunition is added to the platoon's transport weight, and a platoon may not be broken down for transport purposes below the weight of this weapon and ammunition.

## ELECTRONIC WARFARE (EW) EQUIPMENT

**Rules Level:** Experimental

**Available To:** BM, IM, CV, SV, AF, CF, SC, DS

**Tech Base (Ratings):** Inner Sphere (D/X-F-E)

**Game Rules:** The basic EW Equipment system is a one-piece combination that performs the functions of an Inner Sphere Beagle Active Probe and Guardian ECM Suite (see pp. 129 and 134, *TW*). However, the effective range of this combined system is only 3 hexes (for both effects).

Units with multiple active probes and ECM suites of any type may use only one probe and/or ECM at a time in game play. In standard game play, fighters, Small Craft, DropShips and other airborne units may only use probes and ECM suites when interacting with ground units, or in accordance with the advanced rules for aerospace combat covered in *Strategic Operations*.

## FIELD GUNS/FIELD ARTILLERY

Field guns and field artillery are essentially unmounted vehicular-scale ballistic and artillery weapons that can be towed into battle by motorized (and some mechanized) conventional infantry platoons. Far larger than

standard support weapons, they provide substantial firepower, but are heavy, crew-intensive and can slow down a platoon immensely in battle.

### FIELD GUNS

**Introduced:** Pre-spaceflight

Field guns are more easily moved than field artillery, but are easily destroyed because they are highly exposed.

## FIELD GUNS

**Rules Level:** Advanced

**Available To:** CI

**Tech Base (Ratings):** Both (ratings as appropriate *TechManual* Weapon; see pp. 290-291 and 341-343, *TM*)

**Game Rules:** Only motorized conventional infantry platoons or mechanized conventional infantry platoons with a Wheeled or Tracked motive type may be equipped with Field Guns. Each Field Gun requires a number of troopers equal to its weight in tonnage to operate, and is considered destroyed if the platoon's number of troops is reduced below its crew needs. If a Field Gun-equipped platoon has multiple Field Guns, it may only operate as many Field Guns as it can fully man. Each Field Gun in a platoon receives 1 ton of ammunition, which must be tracked during game play. Once a Field Gun is considered destroyed, the infantry unit can move and fire as a normal infantry unit per its type.

Field Guns attack using the range, damage and any applicable modifiers (including those of the weapon class) as their vehicle-mounted counterparts, but they may not be fired in the same turn that the platoon has moved or delivered any attack using its own infantry weapons. Furthermore, in any turn where the Field Guns are to be fired, the controlling player must designate a weapon facing (treated like a vehicular turret arc; see pp. 105-106, *TW*). A platoon with multiple Field Guns may fire all such weapons separately—and at multiple targets, if desired (no Secondary Target modifiers apply to these attacks, as each weapon fires with its own crew)—but all attacks must be made against targets in the same firing arc.

Ultra and Rotary Autocannon Field Guns are immune to jamming or fire control failure effects, and LB-X Autocannon Field Guns must always use cluster munitions. Gauss-based Field Guns are immune to weapon explosion effects.

### FIELD ARTILLERY

**Introduced:** circa 2200 (Terran Alliance)

Field artillery is harder to move than the smaller field guns, making them prone to swift destruction. For this reason, field artillery units rarely operate directly on the front lines.

## FIELD ARTILLERY

**Rules Level:** Advanced

**Available To:** CI

**Tech Base (Ratings):** Both (ratings as appropriate Artillery Weapon; see p. 284)

**Game Rules:** Only motorized conventional infantry platoons or mechanized conventional infantry platoons with a Wheeled or Tracked motive type may be equipped with a single Field Artillery weapon or Artillery Cannon (per platoon). This weapon requires a number of troopers equal to its weight in tonnage to operate, and is considered destroyed if the platoon's number of troops is reduced below its crew needs. A Field Artillery weapon receives 1 ton of ammunition, which must be tracked during game play.

Units with Field Artillery (regardless of motive type) are treated as motorized infantry with 1 MP, and must spend MP to change the weapon's facing, just like a vehicle. The facing of a Field Artillery weapon is treated the same as a vehicular turret arc (see pp. 105-106, *TW*).

Field Artillery weapons attack using the range, damage and any applicable modifiers (including those of the weapon class) as their vehicle-mounted counterparts, but they may not be fired in the same turn that the firing platoon has moved or delivered any attack using its own infantry weapons. Furthermore, in any turn where the Field Artillery is to be fired, its attack must be made into the weapon's appropriate firing arc.

INTRODUCTION

ADVANCED  
GROUND MOVEMENT

ADVANCED  
COMBAT

ADVANCED  
BUILDINGS

ADVANCED  
SUPPORT  
VEHICLES

GENERAL  
RULES

ADVANCED  
SUPPORT VEHICLE  
CONSTRUCTION

ADVANCED  
WEAPONS  
AND EQUIPMENT

INDEX

RECORD SHEETS

# FLAMERS

Long feared on the battlefield, flamers were often more psychologically terrifying than tactically threatening because of their limited range and effectiveness when used alone. With the return of advanced research and

development, even this humble weapon has evolved to ascend from its anti-infantry niche to a potential staple of the modern battlefield.

## EXTENDED-RANGE (ER) FLAMER

**Introduced:** 3067 (Clan Jade Falcon), 3070 (Federated Suns)  
First developed by the Clans, the fusion-based extended-range (ER) flamer variation relies on improved magnetic coils and a narrower muzzle aperture

to achieve more focus and propulsion at the cost of damage and spread. Though now commercially available to both the Inner Sphere and the Clans, this weapon system has yet to find a home on standard vehicles or 'Mechs.

## EXTENDED-RANGE (ER) FLAMER

**Rules Level:** Advanced

**Available To:** PM, BM, IM, CV, SV, AF, CF, SC, JS, DS, SS, WS, MS

**Tech Base (Ratings):** Both (D/X-X-E)

**Game Rules:** In game play, the ER Flamer operates as a fusion-based (non-vehicle) flamer. Against non-infantry targets, it delivers the same armor damage as a standard flamer, but with only half the heat effects (rounded down, to a minimum of 1 heat point). Against conventional infantry, the ER Flamer delivers only 2D6 burst-fire damage, rather than 4D6.

## HEAVY FLAMER

**Introduced:** 3067 (Clan Jade Falcon), 3068 (Lyrn Alliance)  
A heavier, fuel-based version of the flamer, the aptly named heavy flamer provides more power and range through sheer brute force. Also recently

made available to both the Inner Sphere and Clans, heavy flamers have yet to see widespread use, but their devastating anti-infantry effects are sure to change that in the near future.

## HEAVY FLAMER

**Rules Level:** Advanced

**Available To:** PM, BM, IM, CV, SV, AF, CF, SC, DS, MS

**Tech Base (Ratings):** Both (C/X-X-E)

**Game Rules:** Based on the vehicular flamer, but with a higher-pressure, wide-angle muzzle, the Heavy Flamer has greater range and does more damage than the standard flamer, but may not be used in vacuum environments (including space). Against non-infantry units, the Heavy Flamer delivers twice the damage and heat effects as a standard flamer. Against infantry units, the Heavy Flamer delivers 6D6 burst-fire damage, rather than 4D6. A critical hit to the Heavy Flamer's ammunition, however, causes 5 points of damage per unfired shot, reflecting the combination of the highly volatile fuel mixture and the high pressure under which it is kept at all times.

# FLIGHT DECK/HELIPAD

**Introduced:** Pre-spaceflight  
Flight decks and helipads have been a staple of large blue-water naval vessels since the dawn of air power in the early twentieth century. Designed to conduct flight operations, a flight deck consists of a 120-meter deck area,

launching catapults, arresting mechanisms and lift platforms to raise and lower units from the hangar bays to the deck. Similar in virtually every way, helipads offer the same capabilities and features for VTOL-capable units with a much smaller area, taking up only 30 meters of deck space.

**Flamers:** ER and Heavy Flamers may be mounted on any of the listed units in accordance with standard construction rules. ER Flamers, however, cannot be mounted on units that do not use a fusion power source.

**Flight Deck/Helipad:** Flight Decks may only be mounted on Large Naval Support Vehicles and Mobile Structures. Each Flight Deck reduces the number of turrets such units can mount by 3. Large Naval Support Vehicles smaller than a Template C in size cannot mount Flight Decks, while Template C and larger sizes can carry 1 Flight Deck for every 3 hexes of vessel length. Mobile Structures simply require 3 consecutive hexes in a line for each Flight Deck they mount.

Helipads may only be mounted on Large Naval Support Vehicles or Mobile Structures. Each Helipad reduces the number of turrets such units can mount by 1.

**Fluid Gun:** Fluid Guns may be mounted in accordance with the unit's standard construction rules regarding weapons. Fluid Guns are considered ballistic weapons and rely on ammunition, the effects of which can vary based on the chosen ammo type (see *Flamer/Fluid Gun/Sprayer Ammunition*, p. 360). Fluid Gun ammunition must be purchased in full-ton lots and may not be mixed within a given ton. (If the ammo type is unspecified, presume that the Fluid Gun is using Water Ammo.)

**Improved Heavy Gauss Rifle:** The Improved Heavy Gauss may only be mounted in the torso location of 'Mech units, or the non-turret locations on vehicles. Fighters and other units may mount Improved Heavy Gauss Rifles in any location per their standard rules. A fusion or fission engine is required for any unit that is to carry an Improved Heavy Gauss Rifle.

## FLIGHT DECK/HELIPAD

**Rules Level:** Advanced

**Available To:** SV, MS

**Tech Base (Ratings):** Both (B/A-A-A)

**Game Rules:** A single Flight Deck can launch or recover 1 aerospace unit up to 200 tons in weight per minute (6 turns in standard *Classic BattleTech* game play), while a single Helipad requires the same amount of time to launch or recover 1 VTOL-capable aerospace unit weighing up to 200 tons in weight. Any aerospace unit that must land and launch horizontally may land on and launch from a Flight Deck, even if it lacks VSTOL capability, thanks to the arresting gear included in the deck's construction. Only VTOLs and aerospace units up to 200 tons that are capable of vertical landings may land on or launch from a Helipad.

When an aerospace unit launches from a Flight Deck, the controlling player must make a Piloting or Control roll (as appropriate), using the rules for launching fighters and Small Craft (see p. 86, *TW*). In the event of a failed launch roll, any damage is applied to the launching unit's aft, rather than its nose (to reflect the strain of the deck's catapult launch systems). Landing on a Flight Deck uses the same rules for landing fighters and Small Craft (see p. 87, *TW*), but does not require the same runway length, as the deck incorporates arresting gear to "catch" a landing unit more quickly. If a landing roll fails, the landing unit not only suffers the normal crash-landing damage described, but also inflicts damage on the flight deck-equipped unit as if it delivered a successful ramming attack (see p. 241, *TW*). Use the facing from which the landing unit approached to determine the direction of this "attack."

VTOL-capable units may land per their standard rules on a Helipad or a Flight Deck, with damage from any failed Piloting or Control rolls resolved per the same rules. As with Flight Deck landing failures, any crashes on a Helipad also inflict damage to the helipad-equipped unit. In this case, the damage is equal to half the tonnage of the crashing unit (rounded up).

If using advanced weather rules (see p. 57), additional modifiers and rules may apply to all launches and landings on Flight Decks or Helipads.

Once landed on either a Flight Deck or a Helipad, an aerospace unit or VTOL is considered to be "on deck" as unprotected cargo for a minimum of 5 turns after its arrival (before flight deck elevators and the like can bring the unit into its bay), and must have its hex location and facing noted on the unit's template. Any attacks against the carrier unit that strike a hex with a unit on deck also inflict their full damage on the landed unit, resolved against the landed unit's appropriate facing relative to the attack. While a unit may have multiple Flight Decks or Helipads, each Flight Deck can accommodate a maximum of 1 landed fixed-wing unit (including fighters and Small Craft) or 4 landed VTOLs at a time, while each Helipad can accommodate no more than 1 VTOL or aerospace unit at a time.

Submersible units equipped with Flight Decks or Helipads may not perform launching or landing operations while submerged.

## FLUID GUN

**Introduced:** Pre-spaceflight

Essentially a larger version of the commercial sprayer, the fluid gun is an industrial-sized liquid dispenser "weapon" that has gradually expanded its utility over the centuries. Now similar in overall design and range to a

vehicular flamer, the fluid gun is a flexible industrial tool (and short-range weapon in some Solaran arenas) that can hose a target down with varying types of liquid "ammunition." However, it remains a highly uncommon sight on the battlefield.

## FLUID GUN

**Rules Level:** Advanced

**Available To:** BM, IM, CV, SV, AF, CF, SC, DS, MS

**Tech Base (Ratings):** Both (B/B-B-B)

**Game Rules:** Similar to a Flamer, the Fluid Gun is a flexible short-range weapon that sprays liquid "ammunition" at its target, allowing for varied uses. A single Fluid Gun may use multiple fluid "ammo" types (installed in 1-ton bins), but only one can be "fired" per turn. A critical hit to any Fluid Gun ammunition (except for water) produces a 2-point ammo explosion (regardless of the number of shots remaining), along with any special effects caused by a single hit by that type of fluid gun ammunition in the affected location. (CASE II reduces the damage from a Fluid Gun ammo explosion to 1 point, but does not negate the fluid gun ammo special effects.)

Fluid Guns may not be fired underwater or in vacuum, nor can they target airborne units such as fighters, Small Craft, DropShips, VTOLs, or Airship, Fixed-Wing and Satellite Support Vehicles.

## GAUSS RIFLES

With long reach, massive kinetic damage and low waste heat, Gauss weapons are everything a warrior could want—but heavy. Military engineers across the Inner Sphere have used their ingenuity to add new twists

to Gauss weaponry, trying to expand on the one weapon system that nearly parallels Clan technology.

### IMPROVED HEAVY GAUSS RIFLE

**R&D Start Date:** 3061 (Lyran Alliance)

**Prototype Design and Production:** 3065 (Lyran Alliance)

At its debut, the heavy Gauss rifle became one of the most feared weapons on the battlefield, but its sharp damage degradation led Lyran

engineers to an almost immediate effort to develop a more reliable weapon system. Reworking the coils, the improved version promises a more consistent ballistic profile, but sacrifices weight efficiency and range to attain these benefits.

INTRODUCTION

ADVANCED  
GROUND MOVEMENT

ADVANCED  
COMBAT

ADVANCED  
BUILDINGS

ADVANCED  
SUPPORT  
VEHICLES

GENERAL  
RULES

ADVANCED  
SUPPORT VEHICLE  
CONSTRUCTION

ADVANCED  
WEAPONS  
AND EQUIPMENT

INDEX

RECORD SHEETS

## IMPROVED HEAVY GAUSS RIFLE

**Rules Level:** Experimental

**Available To:** BM, IM, CV, SV, AF, CF, SC, JS, DS, SS, WS, MS

**Tech Base (Ratings):** Inner Sphere (E/X-X-F)

**Game Rules:** The Improved Heavy Gauss Rifle uses the same rules to mount, move with and fire as the standard Heavy Gauss Rifle (see p. 136, *TW*), but does not suffer the variable damage effects over range. Furthermore, a critical hit to the Improved Heavy Gauss Rifle results in a 30-point internal explosion, but otherwise follows the rules for an exploding Heavy Gauss Rifle.

## MAGSHOT GAUSS RIFLE

**Introduced:** 3072 (Federated Suns)

Derived from the battle armor-scale variation that debuted on the Federated Suns' Infiltrator Mk. II battlesuit, a larger version of the MagShot has since been produced for use on other units.

## MAGSHOT GAUSS RIFLE

**Rules Level:** Advanced

**Available To:** BM, IM, CV, SV, AF, CF, SC, JS, DS, SS, WS, MS

**Tech Base (Ratings):** Inner Sphere (E/X-X-D)

**Game Rules:** The MagShot functions as a normal, direct-fire ballistic weapon. As with standard Gauss Rifles (see p. 135, *TW*), critical hits to a MagShot result in a 3-point internal explosion, but hits to the weapon's ammunition slots simply render the ammo bin useless.

The Magshot can be linked to a targeting computer.

## SILVER BULLET GAUSS RIFLE

**R&D Start Date:** 3050 (Federated Commonwealth)

**Prototype Design and Production:** 3051 (Federated Commonwealth)

The NAIS, hoping to combine the cluster effect of the LB-X class autocannon with the heavy punch, low-heat, and substantial range of Gauss rifle, initially attempted to develop a Gauss Rifle capable of delivering alternative "splintering" slug types. Unfortunately, the project was too starved for

funds to develop consistently effective flexible ammo-feed mechanisms for the standard Gauss Rifle. Nor were efforts ever completed to adapt pre-fragmented rounds to a conventional Gauss Rifle's barrel or ammo feed. But while this approach met the solicitation requirements to duplicate the LB-X class cluster munitions, the over-specialized Silver Bullet Gauss Rifle and its ammunition proved unattractive to the AFFC, and the project was scrapped.

**MagShot Gauss Rifle:** The vehicular MagShot described here may be installed on any applicable unit in accordance with its standard weapon-mounting rules.

**Silver Bullet Gauss Rifle:** The Silver Bullet Gauss Rifle may be mounted in any available unit in accordance with its standard rules for mounting weapons. The Silver Bullet Gauss Rifle does not count toward the tonnage and size of any targeting computer the unit may install.

**Grav Deck:** Grav decks vary broadly in size. JumpShips and WarShips may mount grav decks as large as 250 meters in diameter, while space stations may mount decks up to 1,500 meters in diameter. (Ground based grav decks, used on large asteroids, may be even larger, but their construction is beyond the scope of these rules.) The weight of a grav deck varies with its size; decks under 100 meters in diameter weigh 50 tons, while decks 100 to 250 meters in diameter weigh 100 tons, and decks over 250 meters to 1,000 meters in diameter weigh 500 tons each. A given unit may mount up to 3 grav decks, plus 1 additional deck for every 100,000 tons of total weight (or fraction thereof). As non-weapon items, grav decks require no assigned location when installed. Full rules on constructing the units that use these items will appear in *Strategic Operations*.

**Grenade Launchers, Vehicular (VGL):** VGLs may be mounted on any location on a Combat Vehicle, Support Vehicle, Fighter, Small Craft or DropShip in accordance with the unit's standard weapon-mounting rules (except for the Rotor location on VTOLs). VGLs mounted on ProtoMechs, Combat Vehicles, Support Vehicles, and Conventional Fighters are treated as ballistic weapons, and so do not require heat sinks.

Mech- and ProtoMech mounted VGLs may only be placed in torso locations, but must also designate their hexside facing (side torso VGLs may fire into front, rear, front-side or rear-side arcs; center torso or ProtoMech-mounted VGLs may only fire front or rear).

**Handheld Weapons:** Only a heavy (vehicular-class) weapon may be constructed as a Handheld Weapon; no items described as "Other Equipment" on the weapon tables (except for Artemis and TAG systems) may be incorporated into a Handheld Weapon design. The total weight of a Handheld Weapon equals the weight of the weapon(s) placed in the handheld mount, plus the number of any standard (single) heat sinks required to fire the weapon(s) at full capacity and the weight of any ammunition required. Ammunition for Handheld Weapons may be added on a per-shot basis, with each shot's weight in tons determined by dividing 1 by the number of shots the weapon normally carries per ton (round the total number of shots assigned to the weapon up to the nearest half ton). Note that Handheld Weapons only require heat sinks for energy-based weapon(s); ballistic and missile weapons require no heat sinks to fire when placed in a Handheld Weapon mount.

A Handheld Weapon may also add armor to its construction, at a cost of 1 ton for every 16 points of armor protection (Handheld Weapons may use only Standard Armor).

When constructing a unit, no tonnage or critical space is required to mount a Handheld Weapon, as the weapon is considered self-contained and separate. However, if a unit is intended to carry Handheld Weapons, it must incorporate two full sets of arm actuators, including hand actuators.

## SILVER BULLET GAUSS RIFLE

**Rules Level:** Experimental

**Available To:** BM, IM, CV, SV, AF, CF, SC, JS, DS, SS, WS, MS

**Tech Base (Ratings):** Inner Sphere (D/X-X-F)

**Game Rules:** The Silver Bullet Gauss Rifle operates under the same rules as an LB-X Autocannon using cluster munitions (using the 15 column of the Cluster Hits Table), including the ability to be used as a flak weapon (see p. 114, *TW*) and the inability to make use of a targeting computer. Unlike LB-X Autocannons, Silver Bullet Gauss rifles may not fire solid slug rounds.

Critical hits to a Silver Bullet Gauss Rifle result in a 20-point internal explosion in the same manner as an exploding standard Gauss Rifle (see p. 135, *TW*), while hits to the Silver Bullet's ammunition bins simply render the affected bins useless.

## GRAV DECK

**Introduced:** Early spaceflight

An amenity created to support long-term living conditions in microgravity (such as on fixed space stations or JumpShips), grav decks are large, structural rings which rotate fast enough to create an approximation of gravity through centrifugal force, allowing for normal activities with few of

the distractions produced by a free-floating environment. Most grav decks produce an equivalent force around one-quarter to one-half Gee to avoid nauseating effects, but larger, faster-spinning grav decks do exist that can produce almost terrestrial gravity with relative comfort for the occupants.

## GRAV DECK

**Rules Level:** Advanced

**Available To:** JS, SS, WS

**Tech Base (Ratings):** Both (B/C-C-C)

**Game Rules:** Grav decks have no direct impact in standard gameplay, but can offset many of the debilitating effects of long-term life in microgravity that can crop up during campaign operations. Such effects are beyond the scope of this book and will be covered in later rulebooks.

## GRENADE LAUNCHERS, VEHICULAR (VGL)

**Introduced:** Pre-spaceflight

As a weapon system, vehicle-mounted grenade launchers (VGLs) lost their popularity with the advent of the BattleMech, which could generally

shrug off the blasts of an entire platoon's worth of grenades. Nevertheless, as a defensive armament or anti-infantry weapon, VGLs have lingered through the centuries, occasionally appearing on modern units in a one-off fashion.

## GRENADE LAUNCHERS, VEHICULAR (VGL)

**Rules Level:** Advanced

**Available To:** BM, IM, PM, CV, SV, AF, CF, SC, DS, MS

**Tech Base (Ratings):** Both (C/D-E-F)

**Game Rules:** Vehicular Grenade Launchers (VGLs) are one-shot launchers that, when fired, automatically deliver their damage effects to all units in the 3 adjacent hexes of their firing arc. Even though they are one-shot weapons, with ammunition included in their weapon slots, critical hits to a VGL do not result in an ammunition explosion. No to-hit roll is required to use a VGL mounted on a ground-based unit or landed aerospace unit; all targets in the affected hexes suffer the same effects.

VGLs cannot be fired while submerged.

Aerospace-mounted VGLs may not be employed in space combat, but VGLs mounted on airborne units (including VTOLs, WiGEs, Airships, Fixed-Wing Support Vehicles and aerospace units) can use these weapons to deliver a single bombing attack against a single target hex in their line of flight. Such an attack affects only one hex, and must be rolled for as a standard Bombing attack (see pp. 245-247, *TW*).

## HANDHELD WEAPONS

**R&D Start Date:** 3050 (Federated Commonwealth)

**Prototype Design and Production:** 3055 (Federated Commonwealth)

On today's battlefield, the term "handheld weapons" commonly refers not to the armaments carried by infantry, but heavy-class weapons built on pistol or rifle-like "handhold" mounts to be used by 'Mech-scaled hands. While the most recent efforts to perfect this technology occurred in the wake of the Clan invasion, when FedCom researchers tested pistol-style handheld weapon mounts, it was the Terran Hegemony's earliest efforts to

design such weapons for 'Mechs like the *Griffin* and the *Phoenix Hawk* that truly saw the first attempts at a universal, portable weapon mount.

Unfortunately, this oft-repeated project never progressed beyond the testing stage, largely because of weight and bulk issues from the weapons' design, as well as the utter lack of adequate safeguards to prevent hostile units from "stealing" such weapons in mid-battle and turning them on their users. More often than not, in fact, engineers through the ages have settled for hard-mounting their "handheld weapons" to the BattleMechs' framework, retaining only the visual appearance of such giant pistols and rifles, rather than a truly modular mount.

INTRODUCTION

ADVANCED  
GROUND MOVEMENT

ADVANCED  
COMBAT

ADVANCED  
BUILDINGS

ADVANCED  
SUPPORT  
VEHICLES

GENERAL  
RULES

ADVANCED  
SUPPORT VEHICLE  
CONSTRUCTION

ADVANCED  
WEAPONS  
AND EQUIPMENT

INDEX

RECORD SHEETS

## HANDHELD WEAPONS



**Rules Level:** Experimental

**Available To:** BM, IM, PM

**Tech Base (Ratings):** Both (D/E-E-F)

**Game Rules:** Handheld Weapons may only be picked up and used by ProtoMech and 'Mech units possessing two functioning hand actuators. Critical hits to a unit's hand actuators force it to drop a Handheld Weapon during the turn's End Phase (or prevent the unit from picking up such a weapon to begin with). However, critical hits to any other arm actuators only add the (cumulative) penalties for making attacks with actuator damage.

Per the 'Mech Lifting Capabilities rule, a ProtoMech or 'Mech unit may only carry a single Handheld Weapon that weighs up to 10 percent of the unit's own total weight (20 percent, if the unit mounts operating Triple-Strength Myomer). However, doing so makes it impossible to make any physical attacks beyond a charge, Death From Above or kick—or to use any weapons mounted in the unit's arms, torso or Main Gun locations.

When used to attack, a Handheld Weapon may only be fired on one target per turn, even if the handheld mount carries multiple individual weapons (such as a handheld mount with 2 medium lasers in it). Because the weapon is self-contained, it will not generate heat, nor can it draw on the unit's on-board ammunition supplies or take advantage of targeting computer and other electronic enhancements installed within the firing unit's chassis.

If a unit using a Handheld Weapon takes a hit to either arm location, the attacker must roll 1D6. On a result of 6, the Handheld Weapon takes the damage instead, and is destroyed if it sustains more damage from the hit than it has armor points.

Handheld Weapons may be picked up or dropped during the End Phase of any turn. Units with functioning hand actuators may only pick up a Handheld Weapon in their own hex. Dropping a Handheld Weapon leaves the weapon in the hex where the unit is currently standing. If a unit carrying a Handheld Weapon falls, it must make an additional Piloting Skill roll to avoid accidentally dropping the weapon, applying any arm actuator damage modifiers in addition to any other applicable Piloting modifiers. A weapon dropped intentionally or otherwise may not be picked up again until the End Phase of the following and subsequent turns.

A dropped Handheld Weapon's location must be noted on the map. Dropped weapons may be targeted for weapon attacks by other units. Such attacks are made at a +1 to-hit modifier, but also apply the -4 immobile target modifier.

## HEAT SINKS

Advanced heat distribution systems have long diminished the vicious cycle of waste heat accumulated by combat units and the energy required to contain the waste's effects, but there has always been room for improve-

ment. While double heat sinks are more efficient, they are space-consuming. Various innovations hope to fill the needs that still linger between double and regular heat sinks.

### COMPACT HEAT SINKS

**R&D Start Date:** 3056 (Federated Commonwealth)

**Prototype Design and Production:** 3058 (Federated Commonwealth)

Inner Sphere researchers devised compact heat sink technology as a means of recovering the internal space lost by bulky systems like endo-steel

internal structure or massive Gauss rifles. Unfortunately, in order to provide the increased internal space, the resulting smaller heat sinks used denser materials and thus grew heavier than their standard counterparts.

## COMPACT HEAT SINKS



**Rules Level:** Experimental

**Available To:** BM

**Tech Base (Ratings):** Inner Sphere (E/X-X-F)

**Game Rules:** Compact Heat Sinks function in the same manner as standard heat sinks for all units capable of carrying them. However, if a 'Mech should suffer a critical hit to a slot that contains 2 Compact Heat Sinks, both sinks are destroyed by the hit.

### LASER HEAT SINKS

**Introduced:** 3051 (Clan Jade Falcon)

The bane of misinformed Inner Sphere physics professors, Clan "laser heat sinks" seemingly violate the laws of thermodynamics by efficiently converting diffuse heat into concentrated laser light that is then ported out of the unit. The overlooked aspect of laser heat sinks is that they are not powered by the heat they are removing (which would be thermodynamically impossible), but by a separate power source (either the unit's engine or emergency bat-

teries in the heat sink). This exotic refrigeration system is somewhat heavier than those of conventional heat sinks, but the elimination of traditional heat sink radiators and large reservoirs of caustic or flammable coolants allows laser heat sinks to match traditional Clan double heat sinks in performance.

One disadvantage of the system is that laser heat sinks function as a "Kick Me" sign during combat in darkness because of the bright light emitted from the heat sink ports.

**Heat Sinks:** Compact Heat Sinks are added and allocated to BattleMechs in accordance with the standard 'Mech construction rules regarding heat sinks (see pp. 53-54, *TM*). However, Compact Heat Sinks are small enough to fit up to 2 sinks in a single critical slot, rather than just 1. A 'Mech using Compact Heat Sinks also doubles the number of heat sinks that need not be allocated to its critical hits table (see p. 53, *TM*). The number of compact sinks assigned to a given slot beyond these "critical-free" sinks must be noted on the unit's record sheet.

Laser Heat Sinks may be mounted on any Clan BattleMech in accordance with the standard 'Mech construction rules regarding heat sinks. Laser Heat Sinks are treated as Clan Double Heat Sinks in every way (including tonnage, heat capacity and critical slot space), but cannot be mixed with standard Double Heat Sinks on the same chassis or mounted on non-BattleMech units.

## LASER HEAT SINKS

**Rules Level:** Advanced

**Available To:** BM

**Tech Base (Ratings):** Clan (F/X-X-E)

**Game Rules:** Laser Heat Sinks function as standard Double Heat Sinks, but the reduction in hot coolant inside the 'Mech reduces the chance of ammunition explosions due to heat, translating to a +1 bonus on rolls to avoid heat-induced ammunition explosions. If the 'Mech takes any action in a turn that generates heat (movement, firing weapons and so on), the night combat or dusk modifier for shots against it is reduced by 1, whether or not the heat is dissipated by the sinks. If the 'Mech's overheats at all (its heat scale rises above 0), night or dusk modifiers no longer apply to any attacks against the unit.

## INFANTRY ARMOR

**Introduced:** Various

A wide range of personal armor is available to today's conventional infantryman. While still not much of a match for heavy weapons, the protection

afforded by personal armor can drastically improve a platoon's chances against anti-infantry weaponry. Moreover, some armor even offers the additional protection of stealth capabilities.

## INFANTRY ARMOR

**Rules Level:** Advanced

**Available To:** CI

**Tech Base (Ratings):** Both (Variable)

**Game Rules:** The Conventional Infantry Armor Table roughly outlines the range of armor types available to conventional infantry. Each armor type has a Damage Divisor, a value that any damage delivered must be divided by before it can be applied to the platoon (including damage determined by dice rolls, such as Burst Fire or Cluster Weapons). This damage is rounded up to the nearest full point before it is applied against the platoon. (For example, if a platoon using Lyran Field Infantry Armor Kits—with a Damage Divisor of 2—is attacked by an LB 20-X AC, the damage to the platoon is computed as if the platoon suffered an 11-point hit  $[(20 + 1) \div 2 = 10.5, \text{ round up to } 11]$ ; if the same platoon were hit by a machine gun—a 4D6 Burst-Fire weapon that rolls up 17 damage points—the armor reduces the damage to 9 points  $[17 \div 2 = 8.5, \text{ round up to } 9]$ .)

In addition, some Infantry Armor may be encumbering or offer stealth modifiers in battle. Encumbering armor is noted with an "E" beside its divisor value and prevents the platoon from engaging in anti-'Mech attacks (in addition to slowing the platoon down, per the construction rules below).

Stealth armor provides additional benefits that may include a Camo To-Hit Modifier (the modifier to attacks—effective against all attackers—against a platoon based on the number of hexes it moved in the round), an IR To-Hit modifier (applied to non-infantry attacks against the platoon based on its range from the Attacker, in addition to standard range modifiers) and ECM Effects (that determine whether or not the platoon can avoid being spotted by non-infantry units with an Active Probe, Light Active Probe or similar systems when using Hidden Unit rules; see p. 134, TW).

To be effective, all troopers in a platoon must carry the same type of armor to gain its effects. Multiple armor types cannot be combined in the same infantry unit.

## CONVENTIONAL INFANTRY ARMOR TABLE

Infantry Armor Type	Damage Divisor*	Tech (Rating)	Availability	Introduced (Date)	Cost (C-bills, each)
Ablative, Standard	1E	Both (D)	A-B-A	2300	1,000
Ablative, Concealed	1	IS (E)	E-D-B	2400	1,500
Ablative/Flak, Standard	1	Both (D)	B-C-B	2305	800
Ablative/Flak, Concealed	1	IS (E)	F-D-C	2400	1,400
Ballistic Plate, Standard	2E	Both (D)	C-C-C	2310	1,600
Ballistic Plate, Concealed	1	IS (E)	X-F-D	2820	2,880
Clothing, Fatigues/Civilian/Non-Armored	1	Both (A)	A-A-A	PS	25
Clothing, Leather/Synthetic Hide	1	Both (A)	A-A-A	PS	100
Clothing, Light (e.g. Summer Wear/None)	0.5	Both (A)	A-A-A	PS	15
Engineering Suit	1E**	Both (D)	D-D-D	2350	7,500
Environment Suit, Light	1E**	Both (C)	B-B-B	2200	200
Environment Suit, Hostile	2E**	Both (D)	C-C-C	2300	10,000
Environment Suit, Marine	2**	Both (D)	C-D-D	2325	15,000
Flak, Standard	1	Both (C)	A-A-A	2200	150
Flak, Concealed	1	IS (D)	D-C-B	2230	225
Heatsuit	1	Both (D)	C-C-C	2355	100
MechWarrior Combat Suit	1	Both (E)	D-F-E	2500	20,000
MechWarrior Cooling Suit	1	Both (E)	D-F-E	2790	500
MechWarrior Cooling Vest (Only)	0.5	Both (D)	C-C-C	2460	200
Myomer, Suit	2E	IS (E)	X-X-E	3047	5,800

INTRODUCTION

ADVANCED GROUND MOVEMENT

ADVANCED COMBAT

ADVANCED BUILDINGS

ADVANCED SUPPORT VEHICLES

GENERAL RULES

ADVANCED SUPPORT VEHICLE CONSTRUCTION

ADVANCED WEAPONS AND EQUIPMENT

INDEX

RECORD SHEETS

## CONVENTIONAL INFANTRY ARMOR TABLE (CONT.)

Infantry Armor Type	Damage Divisor*	Tech (Rating)	Availability	Introduced (Date)	Cost (C-bills, each)
Myomer, Vest	2	IS (E)	X-X-E	3045	1,800
Parka	1	Both (C)	A-A-A	PS	50
Neo-Chainmail	1	IS (D)	X-X-C	3065	920
Snowsuit	1E	Both (C)	A-A-A	PS	70
Spacesuit	1E**	Both (C)	B-B-B	ES	5,000
Spacesuit, Combat	1E**	Both (D)	C-D-E	2200	7,000
Faction Armor Kits:					
Capellan Confederation	1	IS (C)	B-B-B	3050	450
Clan (All)	2	Clan (E)	X-E-E	2900	5,560
ComStar	2	IS (F)	X-F-D	2830	4,280
Draconis Combine	1	IS (C)	B-B-B	2625	360
Federated Suns	1	IS (C)	B-B-B	2330	750
Federated Suns/Commonwealth (3030+)	2	IS (C)	X-D-B	3030	1,040
Federated Suns (3067+)	2E	IS (D)	X-X-D	3067	2,080
Free Rasalhague Republic	1	IS (C)	X-X-B	3040	360
Free Worlds League	1	IS (C)	B-B-B	2290	950
Free Worlds League (3035+)	2E	IS (C)	X-E-B	3035	1,830
Lyran Alliance/Commonwealth	1	IS (C)	B-B-B	2425	650
Lyran Alliance (3060+)	2	IS (C)	X-D-B	3060	730
Magistracy of Canopus	1	IS (C)	B-B-B	2610	400
Marian Hegemony	2	IS (C)	B-B-B	3049	1,580
Taurian Concordat/Calderon	1	IS (C)	B-B-B	3047	370
Word of Blake	2	IS (F)	X-X-D	3055	4,300
Other Periphery/Generic	1	Both (C)	B-B-B	ES	330
Sneak Suits					
DEST Infiltration Suit	1†	IS (D)	X-E-E	2840	50,000
Sneak Suit (One system)	1†	Both (D)	C-C-C	2450	7,000
Sneak Suit (Two systems)	1†	Both (D)	D-D-D	2460	21,000
Sneak Suit (Three systems)	1†	Both (D)	D-E-E	2475	28,000

\*Armor types designated with an "E" are encumbering: -1 MP to platoon; may not execute anti-Mech attacks.

\*\*Infantry wearing these armor types may operate in vacuum.

†See Infantry Stealth Modifiers Table for additional game play effects; for Sneak Suits, each different Sneak armor type counts as one "system," with all stealth modifiers applied cumulatively. For non-infantry attackers, the modifiers from both the Camo and IR columns on that table are cumulative.

## INFANTRY STEALTH MODIFIERS TABLE

Stealth Armor Type	Camo To-Hit Modifier (0/1/2/3/4+ MPs)*	IR To-Hit Modifier (Short/Med/Long)**	ECM Effect**
DEST Infiltration Suit	+1/0/0/0/0	+1/+1/+2	None
Sneak, Camo	+3/+2/+1/0/0	0/0/0	None
Sneak, IR	0/0/0/0/0	+1/+1/+2	None
Sneak, ECM	0/0/0/0/0	0/0/0	Invisible to Standard/Light Active Probes

\*This modifier affects all Attacker to-hits against the stealth unit.

\*\*This modifier affects non-infantry Attacker to-hits against the stealth unit; infantry Attackers ignore these effects.

**Infantry Armor:** A conventional infantry platoon equipped with Infantry Armor must select one type of armor for the entire platoon. Armor types designated as encumbering (with an "E" beside the Damage Divisor) reduce the platoon's mobility by 1 MP (to a minimum of 1 MP per turn), and prohibit the unit from making anti-Mech Leg and Swarm attacks. This mobility restriction is cumulative with modifiers caused by carrying 2 Support Weapons per squad.

**Landing Deck:** A Landing Deck takes up a minimum surface area of 7 hexes (including a central hex and all hexes adjacent to it), and may only be mounted on the top of a Mobile Structure (though the weight of its supports counts against the Mobile Structure's internal tonnage capacity). Landing decks may be built larger, but only by expanding outward from the center hex by 1 hex (to a maximum radius of 3 hexes from the center), and preclude the use of turrets in all hexes the deck occupies. A single Mobile Structure can mount only one Landing Deck. Landing Decks distribute their tonnage across their surface area, so each hex of a Landing Deck weighs the same, regardless of the deck's total size.

# LANDING DECK

**Introduced:** Early Spaceflight

In essence, a Landing Deck is a broader and more heavily reinforced variation on the on the basic flight deck, built to support the launch, landing, and overland transportation of larger space vehicles. Today's landing decks, primarily built to accommodate DropShips, are rare beasts. Featur-

ing specialized lifting mechanisms, heavy tilt-platform elevator systems, and other components, they can hoist vessels that have landed in special prepared sections of modern spaceports for transport to other landing pads, maintenance shelters, or even facilitate a blastoff from the transport vehicle itself.

## LANDING DECK

**Rules Level:** Advanced

**Available To:** MS

**Tech Base (Ratings):** Both (B/C-C-C)

**Game Rules:** A DropShip-scale extension of the conventional flight deck or helipad, landing decks are massive, multi-hex structures of reinforced, heat-dissipating alloys and ferrocrete intended to handle the massive load of a grounded DropShip and—if possible—its launching blast. So large they may only be carried on the rooftop surface of a Mobile Structure, they feature built-in restraining gear, fold-up blasting deflectors, and even personnel/cargo elevators used to load and offload cargo into their supported units. A single landing deck can support a total weight equal to 1,000 tons per hex, and does not lose that capacity unless the supporting Mobile Structure suffers the loss of a third (or more) of its total hexes in size.

# LASERS

The workhorses of modern energy weapons, lasers have been on human-kind's battlefields for over a millennium. Evolved to encompass a range of sizes, they have capabilities ranging from the far-reaching ER variety and rapid-cycling pulse types to devastating heavy class lasers. Spurred on by

the latest waves of unrelenting war, engineers in the Inner Sphere and the Clans have continued to refine laser technology, introducing newer and more exotic variations.

## BINARY LASER (BLAZER) CANNON

**R&D Start Date:** 2801 (Lyran Commonwealth)

**Prototype Design and Production:** 2812 (Free Worlds League)

A scale-up of the infantry Blazer Rifle concept, the Binary Laser (Blazer) Cannon is essentially two large laser cores combined with some redundant components removed. Though researched and prototyped several times (and by several states) during the Succession Wars, the resulting weapon was more akin to an "extra-large" laser than two arrayed lasers, with a heat

load that stymied the weapon's use and prevented its production debut. Ironically, despite the return of double heat sink technology, the Blazer has remained an experimental weapon thanks to other more effective and economical energy weapon developments, like the heavy PPC. Though currently being re-examined by several Inner Sphere laser manufacturers, the Blazer has yet to reach widespread production.

## BINARY LASER (BLAZER) CANNON

**Rules Level:** Experimental

**Available To:** BM, IM, CV, SV, AF, CF, SC, JS, DS, SS, WS, MS

**Tech Base (Ratings):** Inner Sphere (D/X-E-E)

**Game Rules:** The Binary Laser (Blazer) Cannon functions as a standard laser weapon in game play. Though it's technically a twin-barrel laser, hits from a Binary Laser (Blazer) Cannon are resolved as a single hit in gameplay when determining location and critical checks. A unit firing a Binary Laser (Blazer) Cannon may not opt to fire one barrel and not the other.

INTRODUCTION

ADVANCED  
GROUND MOVEMENT

ADVANCED  
COMBAT

ADVANCED  
BUILDINGS

ADVANCED  
SUPPORT  
VEHICLES

GENERAL  
RULES

ADVANCED  
SUPPORT VEHICLE  
CONSTRUCTION

ADVANCED  
WEAPONS  
AND EQUIPMENT

INDEX

RECORD SHEETS

**Lasers:** The advanced laser weapons described above may be mounted in accordance with the appropriate unit's standard construction rules for mounting weapons, with the following modifications for specific instances:

**Bombast Lasers:** Non-heat scale units mounting Bombast Lasers must have sufficient heat sink capacity to handle the largest Bombast Laser discharge (that is, 12 points).

**Chemical Lasers:** When mounted on ProtoMechs, vehicles or conventional fighters, Chemical Lasers are treated as ballistic weapons rather than energy weapons, and therefore do not require power amplifiers or heat sinks on such units. Chemical Laser ammunition must be installed in full-ton lots for all units except ProtoMechs. When mounting Chemical Lasers on ProtoMechs, ammunition may be purchased at a per-shot rate (determined by dividing 1,000 by the number of shots per ton and rounding up to the nearest kilogram).

**X-Pulse Lasers:** Non-heat scale units mounting X-Pulse Lasers must also mount sufficient heat sinks to deal with the weapon's increased heat.

**Laser Anti-Missile System:** The laser anti-missile system follows the standard rules for installing weapons and equipment. The system is considered an energy weapon for purposes of determining the heat sink and power amplifier requirements of units that do not use a heat scale (such as non-fusion powered vehicles and fighters).

## BOMBAST LASER

**R&D Start Date:** 3061 (Lyran Alliance)

**Prototype Design and Production:** 3064 (Lyran Alliance)

The bombast laser is meant to be the ultimate laser weapon without growing to be the heaviest energy weapon. Unfortunately, weight reduction efforts included sacrifices in the power supply, which left the bombast laser as a slow-charging weapon. Rather than hobble the gunner with a weapon that wasn't ready to fire at a critical time, engineers modified the weapon so that it could be triggered prematurely with whatever charge

it had built up. This allowed the bombast laser to be successfully (if not entirely accurately) portrayed as a "flexible" weapon with a "dial-a-yeild" feature. In practice, the bombast laser is a distracting weapon for its user, as its variable charging feature is difficult to manage in the middle of combat. But its powerful damage potential and the showy effect of its pre-fire "glow" (a side effect of the electrical buildup that grows the longer the weapon's fire is held) made it a favorite experimental weapon in the Solaris arenas where it first saw testing.

## BOMBAST LASER

**Rules Level:** Experimental

**Available To:** BM, IM, CV, SV, AF, CF, SC, JS, DS, SS, WS, MS

**Tech Base (Ratings):** Inner Sphere (E/X-X-E)

**Game Rules:** The Bombast Laser may select the level of damage it inflicts, from 7 to 12 points, but suffers an additional to-hit modifier equal to half of the desired damage value minus 7 (rounded up), reflecting the fire-holding factor. (Thus, a Bombast Laser "dialed up" to its maximum damage potential of 12 suffers an additional to-hit modifier of +3 [12 damage - 7 = 5; 5 ÷ 2 = 2.5, round up to 3].) The Bombast Laser's heat is equal to the points of damage selected that turn. Bombast Lasers may not be fired on secondary targets. In all other respects, Bombast Lasers function per standard direct-fire energy weapon rules.

## CHEMICAL LASERS

**R&D Start Date:** 3057 (Clan Hell's Horses)

**Prototype Design and Production:** 3059 (Clan Hell's Horses)

Chemical lasers were actually the first effective energy weapons able to physically damage relatively robust targets, like solid-fueled missiles and unarmored military vehicles. With the advent of economical fusion engines and refinements in electrically powered lasing mechanisms, however, they were quickly overtaken by a new generation of "fuel-free" laser weapons that have become today's standard.

Seeking a more weight-economical alternative to vehicle-mounted lasers (which often require power amplifiers on non-fusion units), Clan Hell's Horses recently returned to the chemical laser concept. Though reliance on chemical "ammunition" (which remains as energetic and highly toxic as the early laser versions) promises to reduce their endurance in combat, the resulting weapons may be mounted on non-fusion vehicles without requiring power packs or heat sinks.

## CHEMICAL LASERS

**Rules Level:** Experimental

**Available To:** BM, IM, PM, CV, SV, AF, CF, SC, JS, DS, SS, WS, MS

**Tech Base (Ratings):** Clan (E/X-X-E)

**Game Rules:** The ammo for Chemical Lasers follows normal ammo explosion rules for critical hits and heat, inflicting damage equal to weapon times the remaining shots in the ammo slot (affected by CASE or CASE II as normal). Although Chemical Lasers are technically energy weapons when fired, because of their ammunition dependency, fighters equipped with these weapons may not use them in a strafing attack.

## ER PULSE LASERS

**R&D Start Date:** 3053 (Clan Wolf)

**Prototype Design and Production:** 3057 (Clan Wolf)

While under-funded Inner Sphere researchers charged the problem of their short-ranged pulse lasers head-on with power increases (creating X-pulse lasers), Clan Wolf researchers labored under an attempt to mate the best of Clan extended range and pulse technologies, which mostly ended up combining some of the high-temperature features of ER optics and

up-rated power supplies to punch the beams out further. The result was a suite of less accurate, longer-ranged pulse lasers. Curiously, these weapons have yet to reach full-scale production, at least partly due to the summary cancellation of the project when many of the original researchers departed with Phelan's Wolves during the Refusal War.

## ER PULSE LASERS

**Rules Level:** Experimental

**Available To:** BA, BM, IM, PM, CV, SV, AF, CF, SC, JS, DS, SS, WS, MS

**Tech Base (Ratings):** Clan (F/X-X-E)

**Game Rules:** In game play, ER Pulse Lasers function in the same fashion as regular pulse lasers (and are compatible with targeting computers in the same fashion), but receive a -1 to-hit modifier rather than -2.

## IMPROVED HEAVY LASERS

**R&D Start Date:** 3066 (Clan Goliath Scorpion)

**Prototype Design and Production:** 3069 (Clan Goliath Scorpion)

While the ER Pulse Laser project was apparently not well supported among the Clans, the success of the Star Adders' heavy laser spurred many Clans to seek a remedy for that weapon's targeting shortcomings. Concerned about the sensor-disrupting and health-endangering radiation emissions of these weapons, but unwilling to compromise on their sheer

destructive power, Clan engineers focused on the weakly shielded "plasma lasing mechanism" that generated so much trouble.

Though simpler solutions included additional shielding, Clan Goliath Scorpion reportedly hit upon a more elegant solution meshing limited shielding with a modified plasma lasing chemistry. The only drawback was the more powerful capacitors needed to power these weapons, which are prone to Gauss-like explosions if damaged in combat.

## IMPROVED HEAVY LASERS

**Rules Level:** Experimental

**Available To:** BM, IM, PM, CV, SV, AF, CF, SC, JS, DS, SS, WS, MS

**Tech Base (Ratings):** Clan (F/X-X-F)

**Game Rules:** Improved Heavy Lasers do not suffer the usual +1 to-hit modifier associated with standard Heavy Lasers. In addition, when an Improved Heavy Laser takes a critical hit, it explodes in the same manner as a Gauss Rifle (see p. 135, TW), but with a damage value equal to half the Improved Heavy Laser's damage. (For instance, an Improved Small Heavy Laser will explode for 3 points [ $6 \text{ damage} \div 2 = 3$ ], while an Improved Heavy Large Laser will explode for 8 points [ $16 \div 2 = 8$ ].)

## VARIABLE SPEED PULSE (VSP) LASERS

**R&D Start Date:** 3066 (Free Worlds League/Word of Blake)

**Prototype Design and Production:** 3070 (Free Worlds League/Word of Blake)

**Introduced:** 3072 (Free Worlds League/Word of Blake)

A variation of the pulse laser concept, the variable speed pulse laser (VSP laser) uses a series of rotating lenses and electronic cut-offs. This system

enables the laser to track a target and alternate the speed with which it generates its pulses, based on range to target. This effect allows the VSP a greater range than a standard pulse laser, but at less damage potential and less accuracy, while such damage and accuracy are conversely increased at shorter ranges.

## VARIABLE SPEED PULSE (VSP) LASERS

**Rules Level:** Advanced

**Available To:** BA, BM, IM, CV, SV, AF, CF, SC, JS, DS, SS, WS, MS

**Tech Base (Ratings):** Inner Sphere (E/X-X-E)

**Game Rules:** In game play, Variable Pulse Lasers function as pulse lasers (and are compatible with targeting computers in the same fashion) in every way, except that the to-hit modifier and damage value changes depending upon the range bracket. At short range, VSP Lasers receive a -3 to-hit modifier and their maximum damage value, while at medium range, they receive a -2 to-hit modifier and reduced damage. At long range, a VSP Laser has a -1 to-hit modifier and delivers its lowest potential damage to the target.

Against conventional infantry, VSP Lasers are treated as direct-fire energy weapons, but add 1 point for attacking infantry at long range, 2 points for medium range and 3 points for short. For example, a Large VSP Laser (damage 11/9/7) attacking infantry at short range would inflict 5 casualties ( $[11 \text{ damage at short} \div 10 = 1.1, \text{ round up to } 2] + 3 \text{ for VSP short range} = 5$ ), while a Small VSP Laser hitting infantry at long range would strike only 2 troopers ( $[3 \text{ damage at long} \div 10 = 0.3, \text{ round up to } 1] + 1 \text{ for VSP long range} = 2$ ).

## X-PULSE LASERS

**R&D Start Date:** 3055 (Federated Commonwealth)

**Prototype Design and Production:** 3057 (Federated Commonwealth)

The X-Pulse Laser began as a FedCom-era experiment aimed at improving the range of existing Inner Sphere-model pulse lasers without sacrificing accuracy. The fracturing of the Federated Commonwealth derailed the project for a while, but not before prototypes were in development that

effectively modified existing Spheroid pulse lasers to cycle faster and with greater power. The results were weapons that gained reach while maintaining accuracy and damage, but suffered from a dramatic increase in waste heat. X-Pulse Lasers were in pre-production trials on Solaris when the Jihad erupted and the planet fell to the Word of Blake, and thus have yet to see widespread use.

## X-PULSE LASERS

**Rules Level:** Experimental

**Available To:** BM, IM, CV, SV, AF, CF, SC, JS, DS, SS, WS, MS

**Tech Base (Ratings):** Inner Sphere (E/X-X-E)

**Game Rules:** In game play, X-Pulse Lasers function in the same manner as standard pulse lasers. Against conventional infantry, the Small X-Pulse Laser delivers 2D6 burst-fire damage.

INTRODUCTION

ADVANCED  
GROUND MOVEMENT

ADVANCED  
COMBAT

ADVANCED  
BUILDINGS

ADVANCED  
SUPPORT  
VEHICLES

GENERAL  
RULES

ADVANCED  
SUPPORT VEHICLE  
CONSTRUCTION

ADVANCED  
WEAPONS  
AND EQUIPMENT

INDEX

RECORD SHEETS

# LASER ANTI-MISSILE SYSTEM

**R&D Start Date:** 3045 (Clan Wolf), 3054 (Federated Commonwealth)  
**Prototype Design and Production:** 3048 (Clan Wolf), 3059 (Federated Suns)

Both Clan and Inner Sphere designers have turned to lasers to produce ammunition-independent anti-missile systems. Based on a modified small pulse laser, the so-called Laser Anti-Missile System (L-AMS) has debuted in prototype form, but has yet to hit mainstream production.

● ●

## LASER ANTI-MISSILE SYSTEM

i

**Rules Level:** Experimental  
**Available To:** BM, IM, CV, SV, SC, DS, SS, JS, WS, MS  
**Tech Base (Ratings):** Inner Sphere (E/X-X-E), Clan (F/X-X-E)  
**Game Rules:** Standard anti-missile system rules apply when using the Laser AMS (see pp. 129-130, *TW*), except the laser system requires no ammunition. Furthermore, an L-AMS attack that reduces a missile flight's Cluster Hits roll to less than 2 completely destroys the incoming flight.

# LASER INSULATOR

**Introduced:** 2575 (Terran Hegemony)  
**Extinct:** 2820  
**Reintroduced:** N/A

Simple in concept, the laser insulator first debuted on the Star League's *Chippewa* fighter. These high quality, rugged aerogel blankets insulated the laser bays of the *Chippewa's* wings from the superstructure and core systems, giving the aerospace fighter the equivalent of two additional heat

sinks. The excellent, lightweight insulation was irreplaceable by the Great Houses during the Succession Wars, but remained within the reach of Clan technology. The Clans did not make widespread use of the system, however, as it suffered a significant drawback: in bottling up the laser's waste heat, rather than allowing it to flow through the entire unit to act as a thermal mass, the lasers became very hot and suffered frequent failures.

● ●

## LASER INSULATOR

i

**Rules Level:** Experimental  
**Available To:** BM, IM, CV, SV, AF, CF, SC  
**Tech Base (Ratings):** Inner Sphere (E/X-F-F), Clan (E/X-E-F)  
**Game Rules:** Laser Insulators reduce the heat output of laser weapons by 1 point per insulated laser (to a minimum of 1). When an insulated laser (a laser mated to a Laser Insulator) makes an unmodified attack roll with a result of 2, the controlling player must roll 2D6. On an 8 or higher, the insulated laser suffers a critical hit, reflecting damage from overheating.

**Laser Insulator:** Laser insulators are limited to smaller units (200 tons and less) with distinct hit locations, and must always be placed in the same location as the weapon they are insulating. Units that do not use BattleMech critical hit space treat insulators as part of the weapon itself. Laser Insulators may only be used in conjunction with standard-scale laser types (including Chemical, ER, Improved Heavy, Heavy, Pulse, Standard and X-Pulse).

**Light Sail:** Only Satellite Support Vehicles can mount a Light Sail. A Light Sail occupies 1 rear equipment slot on a satellite and masses 10 percent of the satellite's mass (rounded up to the nearest kilogram for Small-sized satellites or to the nearest ton for satellites 5 tons and over).

**Lithium-Fusion Battery:** A Lithium-Fusion Battery weighs 1 percent of the total mass of the vessel being equipped with the battery, and is automatically considered part of the vessel's main body. Full rules on constructing the units that use these items will appear in *Strategic Operations*.

**Mass Driver:** Mass Drivers can only be installed in WarShips and space stations, and the size of such units limits the size of the largest Mass Driver that may be mounted (see the Mass Driver Vessel Limits Table below). A WarShip may mount only a single Mass Driver of any size, while a space station may mount a maximum of 1 Mass Driver per firing arc.

The Mass Driver is the only capital-scale weapon that can exceed the 70-point limit on weapon bay size, and requires 10 gunners to operate. When computing a vessel's fire control requirements, a Mass Driver counts as 10 capital weapons. Full rules on constructing the units that use these items will appear in *Strategic Operations*.

## MASS DRIVER VESSEL LIMITS TABLE

Mass Driver	Vessel Minimum Tonnage
Light	750,000
Medium	1,500,000
Heavy	2,000,000

# LIGHT SAIL

**Introduced:** 2165 (Terran Alliance)

Not to be confused with the giant solar sails used by JumpShips and WarShips, the light sail is used by some satellites to maintain longstanding station-keeping positions (typically at or near zenith and nadir jump point

positions) without drawing on reaction mass that can be depleted within a month's time. The Terran Alliance introduced these "passive propulsion systems" on surveillance satellites intended to monitor incoming and outgoing JumpShip traffic.

## LIGHT SAIL

**Rules Level:** Advanced

**Available To:** SV

**Tech Base (Ratings):** Both (C/C-E-D)

**Game Rules:** Light Sails are functionally similar to Jump Sails. They have a Sail Integrity of 1, are furled and unfurled like JumpShip sails and may be attacked with the same rules as attacking a JumpShip sail. However, the Light Sail generates no power for the satellite and is considered destroyed if the sail itself suffers more than 1 capital-scale point of damage or the satellite suffers structural integrity damage from the rear. Satellites with thrusters and a Light Sail may not use their thrusters while the Light Sail is deployed.

# LITHIUM-FUSION BATTERY

**Introduced:** 2531 (Terran Hegemony)

**Extinct:** 2819 (Inner Sphere)

**Recovered:** 3043 (Federated Commonwealth)

The lithium-fusion battery was a pre-Star League innovation that allowed JumpShips and WarShips to store a second charge for their Kearny-Fuchida (K-F) drives. This second jump could be triggered in short succession to the

first, which allowed a JumpShip to cross up to 60 light-years in minutes, avoid ambushes, launch lightning raids at unparalleled distances and conduct other revolutionary interstellar maneuvers. Regrettably, it was never feasible to mount more than one lithium-fusion battery on a JumpShip, and the batteries took as long to recharge as the K-F drive to avoid damage, but the improvement over conventional single-jump vessels was substantial.

## LITHIUM-FUSION BATTERY

**Rules Level:** Advanced

**Available To:** JS, WS

**Tech Base (Ratings):** Inner Sphere (E/E-X-E), Clan (E/X-E-D)

**Game Rules:** A Lithium-Fusion Battery enables a WarShip or JumpShip so equipped to store an additional drive charge. This extra charge allows the vessel to make two jumps in succession, while avoiding the enormous risks of quick-charging the K-F drive through the fusion reactor. Jump point calculations may be made for both jumps prior to making the first jump, or before each jump (those rules are covered in *Strategic Operations*). As with the K-F drive core, a Lithium-Fusion Battery may be charged by the vessel's jump sail, its fusion reactor or a space station's Energy Storage Battery (see p. 306). However, each method can charge only one device at a time. For example, if the jump sail is charging the K-F drive core, the vessel's Lithium-Fusion Battery must receive its charge from the fusion reactor or a space station's Energy Storage Battery.

# MASS DRIVER

**R&D Start Date:** circa 2700 (Terran Hegemony)

**Prototype Design and Production:** circa 2715 (Terran Hegemony)

Essentially a Gauss rifle built on titanic scale, the weaponized mass driver—derived from early spaceflight mass conveyors used by asteroid miners in the Terran system—propels a solid projectile about the size of a Battle-Mech at incredible velocities. The kinetic energy released upon impact makes the mass driver almost as destructive as a small nuclear weapon. Theorized and prototyped in the late Star League era, the tremendous expense and

size requirements for this weapon—which requires a WarShip-length series of coils and significant reinforcing structures to be effective—prevented its completion and full-scale production. However, FedSuns engineers working at the Galax Yards were rumored to be in the midst of constructing their own prototype just before the start of the Jihad, and some pre-Jihad rumors also suggested that the Word of Blake was fielding industrial mass conveyors modified to function in a similar fashion.

## MASS DRIVER

**Rules Level:** Experimental

**Available To:** SS, WS

**Tech Base (Ratings):** Inner Sphere (D/X-X-F)

**Game Rules:** A Mass Driver has a very limited field of fire, and can only engage targets directly in line with the nose of the vessel on which it is mounted. Space stations suffer from similar restrictions, with the Mass Driver only able to fire at a target directly in line with the firing arc's hex facing. Furthermore, Mass Drivers suffer a +2 to-hit modifier to attack, in addition to all other range and conditional modifiers.

INTRODUCTION

ADVANCED  
GROUND MOVEMENT

ADVANCED  
COMBAT

ADVANCED  
BUILDINGS

ADVANCED  
SUPPORT  
VEHICLES

GENERAL  
RULES

ADVANCED  
SUPPORT VEHICLE  
CONSTRUCTION

ADVANCED  
WEAPONS  
AND EQUIPMENT

INDEX

RECORD SHEETS

## 'MECH MORTARS

**Introduced:** 2531 (Terran Hegemony)

**Extinct:** 2819 (Inner Sphere)

**Recovered:** 3043 (Federated Commonwealth)

A rather old-fashioned concept, more akin to short-range artillery than a dedicated anti-vehicle weapon system, 'Mech-based mortars never really

caught on through the centuries, especially thanks to the existence of more effective missile launchers, and had largely vanished from Inner Sphere battlefields by the mid-29th century. Regardless, some agencies—noting these weapons' immunity from anti-missile fire—have explored their potential as a suppression-fire alternative to LRMs, reviving the concept for modern times.

### 'MECH MORTARS

**Rules Level:** Advanced

**Available To:** BM, IM, CV, SV, MS

**Tech Base (Ratings):** Both (B/D-F-E)

**Game Rules:** Though their damage effects vary with the mortar types chosen (see p. 373), 'Mech Mortars otherwise operate in the same fashion as LRMs, and may be fired directly or indirectly per the standard game play rules. If fired indirectly, 'Mech Mortars follow all of the standard rules for LRM Indirect Fire (see p. 111-112, *TW*), but do not require a completely blocked line of sight or a spotter to execute (though an additional +2 to-hit modifier applies if no spotter is present, reflecting the general lack of guidance systems on the mortar shells). If fired directly, a +3 to-hit modifier applies to the 'Mech Mortar attack because the shells still fly in an arcing trajectory towards the target.

'Mech Mortars may only be fired by ground-based units. Airborne units may not fire 'Mech Mortars, nor may 'Mech Mortars be fired while submerged.

Anti-Missile Systems (including Standard and Laser types) may not engage incoming 'Mech Mortar flights.

## MECHANIZED VTOL INFANTRY

**Introduced:** Early spaceflight

The most mobile of the mechanized conventional infantry types, VTOL-mechanized infantry are also the rarest platoon type in the modern battlefield. Employing collapsible, ultra-small aircraft (called "microlites") and helicopters ("microcopters"), these troops are ideal for reconnaissance and spotting duties, but are lightly armed compared to their more

conventional kin. The term "mechanized" as it is applied to these infantry is technically a misnomer. Other mechanized troop types (hover, wheeled and tracked) are deployed utilizing full-scale vehicles. As such, technically, these specific troop type should be classified as "motorized," but standard usage by most militaries terms them mechanized.

### MECHANIZED VTOL INFANTRY

**Rules Level:** Advanced

**Available To:** CI

**Tech Base (Ratings):** Both (C/D-E-D)

**Game Rules:** Whether they are comprised of Microlite or Micro-Copter troops, Mechanized VTOL conventional infantry platoons may move using VTOL MPs (including take off, landing, and terrain restrictions while in flight). In addition, these troops may move on the ground at 1 MP per turn as a standard foot infantry platoon, as desired. Microlite VTOL infantry receive a base of 6 VTOL MP, but must enter at least 1 hex per turn to remain in flight, while Micro-Copter platoons start with a base of 5 VTOL MP, and may hover in flight at a cost of 0 MP. As with most other mechanized conventional platoons, VTOL-Mechanized infantry cannot execute anti-'Mech attacks.

**'Mech Mortars:** 'Mech Mortars may be mounted on any applicable unit in accordance with the unit's normal weapon-mounting rules. 'Mech Mortar ammunition of any type may only be installed in full-ton lots.

**Mechanized VTOL Infantry:** Regardless of the technology base used, Mechanized VTOL conventional platoons operate at a maximum of 4 squads. Mechanized VTOL platoons may not be broken down to smaller sub-units than an individual squad, even for transport purposes.

**Microlite VTOL Platoons:** These platoons assign 2 troopers per squad, but may not carry any Support Weapons.

**Micro-Copter VTOL Platoons:** These platoons employ 4 troopers per squad, and may carry between 0 and 1 Support Weapon per squad. If any Support Weapons are included in the platoon, however, the platoon suffers a -1 VTOL MP modifier.

**MechWarrior Aquatic Survival System (MASS):** The MASS must always be mounted in the location where the 'Mech's cockpit is placed.

**Mine Dispensers:** Only BattleMechs, IndustrialMechs, ProtoMechs, Combat Vehicles, Support Vehicles (excluding satellites), fighters, Small Craft and Mobile Structures may employ Vehicular Mine Dispensers. Only Battle Armor may employ Battle Armor Mine dispensers. Only Satellite Support Vehicles, Aerospace Fighters, Small Craft, DropShips, Space Stations, JumpShips and WarShips may employ Space Mine Dispensers. Mine dispensers may be mounted on any applicable unit in accordance with its standard rules for installing weapons.

Vehicular and Battle Armor Mine Dispensers receive only 2 shots per dispenser (of the same mine type, which may be determined before game play), and may not install additional mine ammo.

Space Mine Dispensers are treated as standard-scale Point-Defense weapons when mounted on Aerospace Fighters, satellites, Small Craft and advanced aerospace units, and follow the standard rules for mounting such weapons on such units, including gunner requirements and weapon limits per location.

# MECHWARRIOR AQUATIC SURVIVAL SYSTEM

**R&D Start Date:** 3045 (Federated Commonwealth)

**Prototype Design and Production:** 3048 (Federated Commonwealth)

Today's MechWarrior Aquatic Survival System (MASS) was initially developed by Snorkel's of Bracken Swamp for the more exotic underwater arenas on Solaris VII, where it is designed to give warriors trapped in a breached,

submerged cockpit time to get clear of the water. The system's weight and bulk, however, combined with the rarity of submerged engagements, consigned the MASS to limited use, and full production never occurred. According to all accounts, the Clan version is derived directly from the Inner Sphere model, likely a result of Diamond Shark exchanges.

## MECHWARRIOR AQUATIC SURVIVAL SYSTEM (MASS)

**Rules Level:** Experimental

**Available To:** BM, IM

**Tech Base (Ratings):** Both (D/X-X-D)

**Game Rules:** A submerged 'Mech equipped with a MASS that suffers an armor breach to the location in which the cockpit is placed must make a 2D6 roll each turn for up to 180 turns (30 minutes) thereafter that the cockpit area remains (or becomes) submerged. On any result of 11 or less, the unit's cockpit and life support systems ignore the full effects of a cockpit breach and the 'Mech may operate at a +1 penalty to Piloting only—though its sensors will be flooded and disabled. If the roll result is 12, or the unit spends more than 180 total turns underwater, the MASS will fail and the cockpit area will completely flood, forcing the MechWarrior to bail out or die.

While this system protects the cockpit and life support systems, allowing them to function in the event of a breach, it does not protect any other systems such as sensors (or the engine and gyro on a 'Mech with a torso-mounted cockpit). In the event of a flooded torso location on a unit using MASS, the 'Mech will be immobilized and the MechWarrior must await rescue or take the risk of bailing out.

# MINE DISPENSERS

Almost as old as minesweepers, mine dispensers allow for the seeding of a large area with mines, whether on land, sea or in space.

## VEHICLE AND BATTLE ARMOR DISPENSERS

**Introduced:** Pre-spaceflight (Vehicular),  
3050 (Capellan Confederation [Battle Armor])

Vehicle mine dispensers have been in use before man left earth. It was not until the coming of the Clans and the sudden ramp up of development of Inner Sphere battle armor that the Capellan Confederation wedded a mine dispenser to battle armor.

## VEHICLE AND BATTLE ARMOR DISPENSERS

**Rules Level:** Advanced

**Available To:** BA, PM, BM, IM, CV, SV, AF, CF, SC, MS

**Tech Base (Ratings):** Both (B/E-E-E [Vehicular], D/X-X-E [Battle Armor])

**Game Rules:** Vehicular (vehicle- and 'Mech-based) Mine Dispensers are specialized "launchers" that deposit mines in a unit's hex while in motion. Ground-based units, including 'Mechs, ProtoMechs and Combat or Support Vehicles using wheeled, tracked, hover or WiGE motive systems, may deploy any land-type minefield at the beginning or end of their Movement Phase (regardless of the movement mode chosen). The minefield deployed will be a standard-strength field, which automatically fills the unit's designated target hex (either its starting hex or its final hex). Naval vehicles operating on or below the surface of the water (to a maximum of Depth 12) may deploy sea-type mines in the same fashion, but may not deploy mines not specifically identified as sea mines (such as Active mines). Airborne vehicles, Conventional Fighters, Aerospace Fighters and Small Craft operating above the ground map with Vehicular Mine Dispensers may deploy mines per the standard rules for a bombing attack (see pp. 245-246, *TW*).

Battle Armor Mine Dispensers may deploy their mines in the same fashion as ground-based units using a Vehicular Mine Dispenser, but may only use Jumping (or VTOL) MP to do so.

Minefields deployed using Vehicular or Battle Armor Mine Dispensers have a standard damage value of 10 per "shot" regardless of the mine type deployed. Though they incorporate 2 shots into their tonnage and critical space, Vehicular Mine Dispensers do not cause ammunition explosions if hit (or from overheating effects).

## SPACE DISPENSERS

**Introduced:** Early spaceflight (Space)

Introduced during the time of the Terran Alliance, space dispensers—along with space mines—remain relatively rare. Too easy for incoming commercial ships to stray into space minefields, they are often impractical

as a defensive strategy, even on the most important of worlds. They are most often employed when an enemy moves to seize control of a system and are looking to isolate it from outside reinforcements.

INTRODUCTION

ADVANCED  
GROUND MOVEMENT

ADVANCED  
COMBAT

ADVANCED  
BUILDINGS

ADVANCED  
SUPPORT  
VEHICLES

GENERAL  
RULES

ADVANCED  
SUPPORT VEHICLE  
CONSTRUCTION

ADVANCED  
WEAPONS  
AND EQUIPMENT

INDEX

RECORD SHEETS

## VEHICLE AND BATTLE ARMOR DISPENSERS

**Rules Level:** Advanced

**Available To:** SV, AF, CF, SC, DS, JS, WS, SS

**Tech Base (Ratings):** Both (D/E-F-E)

**Game Rules:** Space Mine Dispensers may only be used on the space map, though any placed closer than 10 hexes (180 kilometers) from a planet's space/atmosphere interface suffer the effects of gravity and drift toward the planet surface at a rate of 1 hex per turn (becoming ineffective if they strike the interface or pass below it). Space minefields are deployed in the hex the dispensing unit occupies at the end of its Movement Phase. If the unit is not stationary (Velocity of 0), the minefield will continue to move in the direction and at the velocity of the unit's travel at the time of deployment (modified for gravity if within 10 hexes of an interface as noted above). Out-of-control units may not deploy space mines.

The damage capacity for a Space Mine Dispenser is based on the size of the unit passing through the field, rather than the launcher itself, and so a space mine cluster receives an attack capacity instead (the number of "attacks" the minefield can make before being too dispersed to remain effective). The value for that attack capacity is 6 for each space cluster deployed.

## MINESWEEPER

**Introduced:** Pre-spaceflight

A technology as old as the widespread use of minefields in Terra's World

Wars, minesweepers are designed to detonate mines at a safe distance in front of the vehicle, clearing a path for other units.

## MINESWEEPER

**Rules Level:** Advanced

**Available To:** CV, SV, MS

**Tech Base (Ratings):** Both (C/C-C-D)

**Game Rules:** Minesweeper equipment begins play with an effective Armor Value of 30 points, though the equipment cannot be used as additional armor and will not stop attacks against the Minesweeper vehicle even if the attack passes through the sweeper's facing arc. Maritime Minesweepers are effective only against sea-type minefields; Land Minesweepers are effective only against land-based minefields.

As their name suggests, Minesweepers operate by simply moving a minesweeping vehicle through a mined hex, but their effectiveness varies with the minefield.

If the hex contains a vibrobomb minefield, the Minesweeper will automatically set off and clear the field if the sweeping vehicle is within 9 tons of the minefield's tonnage setting, taking 10 points of damage to the Minesweeper equipment.

Against active, Inferno and standard (conventional) minefields, the player controlling the sweeper must roll a normal mine explosion check upon entering the mined hex, but will set off (and clear) the mines with the sweeper on a result of 6+ (sustaining 6 points of damage to the Minesweeper equipment); if multiple mine types are located in a single hex, this roll must be made for each type of minefield. If this roll fails, the minesweeping vehicle itself may still set off the mines under the mines' normal rules (see p. 207), but sustains any minefield damage to the Minesweeper's location rather than to the Minesweeper equipment itself, and leaves the field active per the mines' standard rules.

Minesweepers have no effect on command-detonated minefields.

Minesweeper equipment remains fully effective until its "armor" falls to 0 (or less), at which point the Minesweeper is treated as a destroyed item. Damage in excess of a minesweeper's Armor Value transfers automatically to the location where the sweeper is mounted.

## MISSILE LAUNCHERS

Missiles are a staple of the modern battlefield, among both the Clans and the Inner Sphere. It comes as no surprise, therefore, that these weapons have been

targeted for further development over the centuries, with a number of newer missile and launcher types entering the prototype stages in recent years.

## ENHANCED LONG-RANGE MISSILE (NLRM) LAUNCHERS

**R&D Start Date:** 3055 (Federated Commonwealth)

**Prototype Design and Production:** 3058 (Federated Commonwealth)

One of the earliest efforts to improve on Inner Sphere LRMs in the face of the dramatically superior performance profile of the Clan models, the

Enhanced LRM (NLRM) uses more sophisticated arming mechanisms to improve its targeting and tracking in close combat. The effect is a launcher system that sharply reduces its minimum range "blind spot" while retaining the overall effectiveness and flexibility of the centuries-proven technology.

**Minesweeper:** Minesweepers are available only in Land-based and Maritime types, which must be designated upon construction. Land-based Minesweepers are available only to ground-based Mobile Structures or vehicles using a Wheeled or Tracked motive system. Maritime Minesweepers may only be mounted on vehicles using displacement hull, hydrofoil or submarine motive systems, or on Mobile Structures with a naval motive system. Minesweeper equipment must always be mounted in a vehicle's front or rear locations (or the front-side/rear-side locations, for particularly large vehicles), or in the outer-most hexes of a Mobile Structure.

**Missile Launchers:** All of the Missile Launchers described here may be mounted in accordance with the unit's standard construction rules. ProtoMechs mounting a permitted missile system may install ammunition by the volley rather than by the ton (to find the per-volley weight, divide 1,000 by the weapon's listed ammo-per-ton value for a single tube; then multiply that by the number of missiles in the volley to find the kilogram weight of a single volley, rounded up to the nearest whole kg). Regardless of the number of tubes in a volley, a ProtoMech need only assign a single weapon slot to the launcher.

## ENHANCED LONG-RANGE MISSILE (NLRM) LAUNCHERS

**Rules Level:** Experimental

**Available To:** BM, IM, CV, SV, AF, CF, SC, JS, DS, SS, WS, MS

**Tech Base (Ratings):** Inner Sphere (E/X-X-F)

**Game Rules:** Enhanced LRM Launchers function just like their standard LRM equivalents in game play, including their ability to fire indirectly, use multiple ammunition types and work with missile enhancement technologies such as Narc and Artemis fire-control systems.

The maritime equivalent of the Enhanced LRM (NLRM) is the Enhanced LRT (NLRT).

## EXTENDED LONG-RANGE MISSILE (ELRM) LAUNCHERS

**R&D Start Date:** 3052 (Federated Commonwealth)

**Prototype Design and Production:** 3054 (Federated Commonwealth)

Weapon design teams at Coventry Metal Works conceived the so-called extended long-range missile system as a means to offset the tremendous range advantages of most Clan weaponry. Though the first prototypes were plagued by heat problems, the Coventry teams overcame this obstacle

by developing a unique two-stage booster system. Unfortunately, these enhanced launchers and their warheads proved incompatible with the enhanced targeting systems and specialized munitions available to standard LRMs. Between efforts to overcome this and the breakup of the Federated Commonwealth, these weapons failed to reach widespread production before the Jihad.

## EXTENDED LONG-RANGE MISSILE (ELRM) LAUNCHERS

**Rules Level:** Experimental

**Available To:** BM, IM, CV, SV, AF, CF, SC, JS, DS, SS, WS, MS

**Tech Base (Ratings):** Inner Sphere (E/X-X-F)

**Game Rules:** Extended Long-Range Missiles (ELRMs) use the same basic rules for LRMs (including LRM indirect fire), but may not benefit from special LRM munitions or targeting enhancers like Narc, iNarc and Artemis fire control systems. Furthermore, when attacking targets within their minimum range (when the missiles' booster rockets are still in use), ELRMs that make a successful attack must use the Cluster Hits column for half their rated rack size (rounded up). For example, an ELRM-15 that hits within its minimum range would roll on the 8 column for Cluster Hits, rather than the 15 column ( $15 \div 2 = 7.5$ , round up to 8).

## IMPROVED ONE-SHOT (I-OS) MISSILE LAUNCHERS

**Introduced:** 3056 (Draconis Combine), 3058 (Clan Nova Cat)

One-shot missile launchers were always a quick-fix design, taking existing launchers and sealing off the ammunition feed mechanisms to contain a single, "unchambered" flight of missiles. Developed after the Clan Invasion in

an effort to further streamline these weapons, DCMS engineers discovered how to do away with the ammo feed mechanisms entirely by placing the missiles directly in the launch tubes, a trick the Nova Cats would soon copy.

## IMPROVED ONE-SHOT (I-OS) MISSILE LAUNCHERS

**Rules Level:** Advanced

**Available To:** BM, IM, PM, CV, SV, AF, CF, SC, JS, DS, SS, WS, MS

**Tech Base (Ratings):** Both (B/X-X-F)

**Game Rules:** Improved One-Shot (I-OS) Missile Launchers function exactly as their standard counterparts, but receive only a single volley during game play, and may not carry additional ammunition. The single shot carried by an I-OS launcher may be of any munition type available to the weapon type itself.

## STREAK LRM LAUNCHERS

**R&D Start Date:** 3055 (Clan Coyote)

**Prototype Design and Production:** 3057 (Clan Coyote)

In an effort to enhance the efficiency of existing LRM launch systems, Coyote scientists successfully managed to adapt the powerful Streak

targeting technology. The result was a weapon system that sacrifices the indirect-fire capabilities of the standard LRM, but also conserves ammunition as effectively as Streak SRMs, ensuring the maximum possible yield when fired.

## STREAK LRM LAUNCHERS

**Rules Level:** Experimental

**Available To:** BM, IM, PM, CV, SV, AF, CF, SC, JS, DS, SS, WS, MS

**Tech Base (Ratings):** Clan (F/X-X-F)

**Game Rules:** Streak LRMs function identically to Streak SRMs (see p. 138, *TW*). Streak LRMs may not be fired indirectly, and may not use specialty ammunition.

INTRODUCTION

ADVANCED  
GROUND MOVEMENT

ADVANCED  
COMBAT

ADVANCED  
BUILDINGS

ADVANCED  
SUPPORT  
VEHICLES

GENERAL  
RULES

ADVANCED  
SUPPORT VEHICLE  
CONSTRUCTION

ADVANCED  
WEAPONS  
AND EQUIPMENT

INDEX

RECORD SHEETS



• M-POD •  
[PAGE 330]

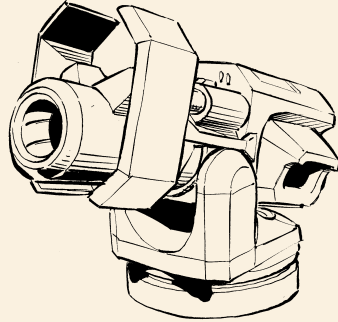

• SUB-CAPITAL CANNON •  
[PAGE 343]

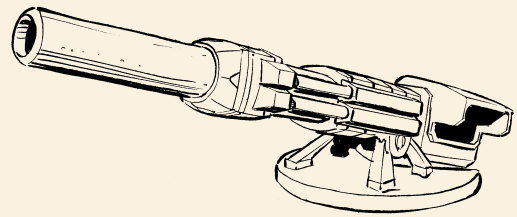

• NAVAL AUTOCANNON (CAPITAL AC) •  
[PAGE 331]

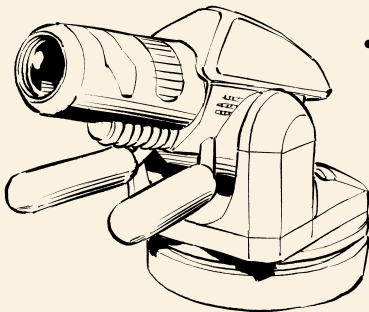

• SUB-CAPITAL LASER •  
[PAGE 343]

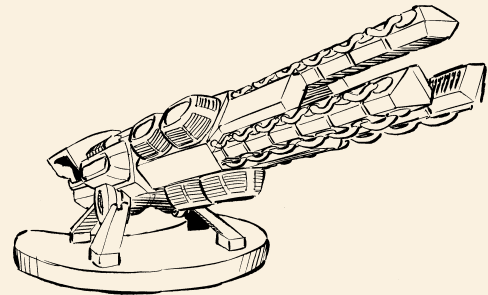

• NAVAL GAUSS (CAPITAL GAUSS) •  
[PAGE 333]

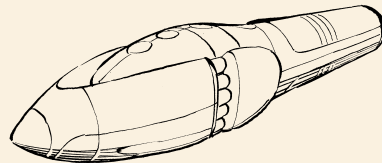

• PIRANHA (SUB-CAPITAL MISSILE) •  
[PAGE 344]

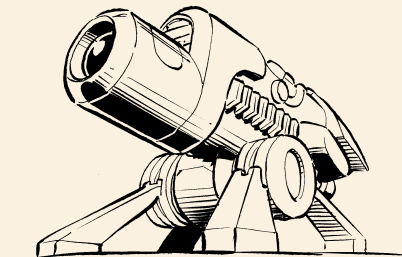

• NAVAL LASER (CAPITAL LASER) •  
[PAGE 333]

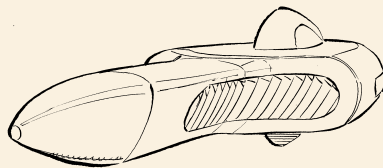

• STINGRAY (SUB-CAPITAL MISSILE) •  
[PAGE 344]

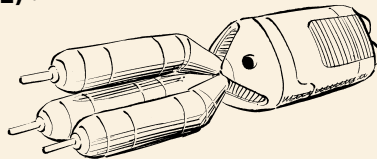

• SWORDFISH (SUB-CAPITAL MISSILE) •  
[PAGE 344]

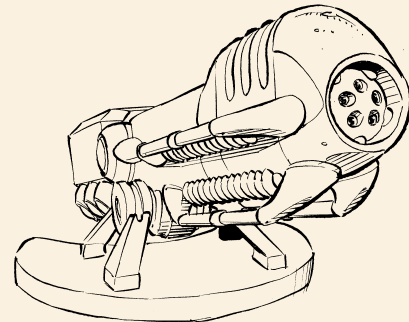

• NAVAL PPC (CAPITAL PPC) •  
[PAGE 333]

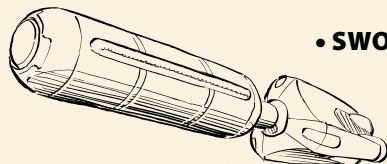

• MANTA RAY (SUB-CAPITAL MISSILE) •  
[PAGE 344]



• **VTOL MAST MOUNT** •  
[PAGE 350]

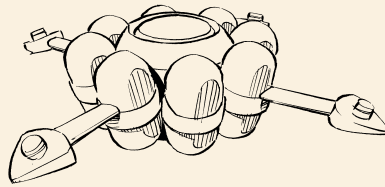

• **INFERNO MIND (LAND/SEAT)** •  
[PAGE 366]

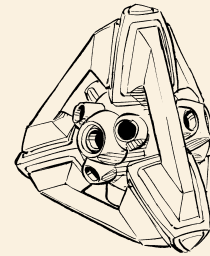

• **SPACE MINE (SPACE)** •  
[PAGE 366]

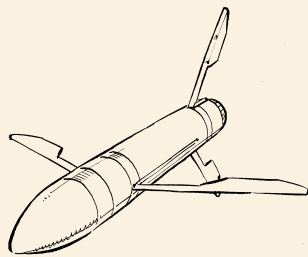

• **AIR-DEFENSE ARROW (ADA) MISSILE** •  
[PAGE 353]

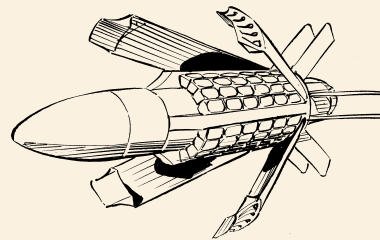

• **ARROW IV (CLUSTER) MISSILE** •  
[PAGE 354]

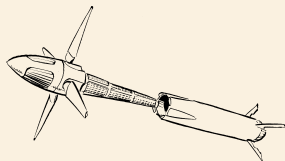

• **ARROW IV (ILLUMINATION) MISSILE** •  
[PAGE 355]

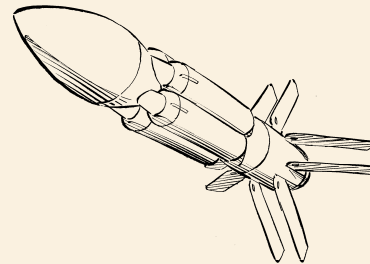

• **ARROW IV (LASER-INHIBITING) MISSILE** •  
[PAGE 356]

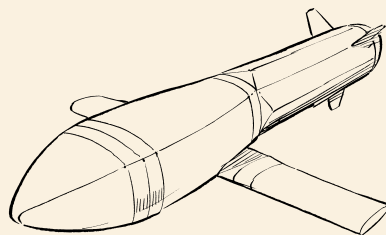

• **ANTI-SHIP (AS) MISSILE** •  
[PAGE 358]

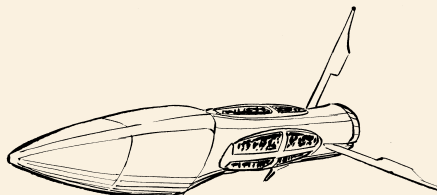

• **ANTI-SHIP ELECTRONIC WARFARE (ASEW) MISSILE** •  
[PAGE 358]

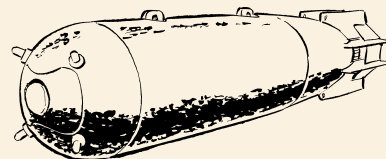

• **TORPEDO BOMB** •  
[PAGE 360]

INTRODUCTION

ADVANCED  
GROUND MOVEMENT

ADVANCED  
COMBAT

ADVANCED  
BUILDINGS

ADVANCED  
SUPPORT  
VEHICLES

GENERAL  
RULES

ADVANCED  
SUPPORT VEHICLE  
CONSTRUCTION

ADVANCED  
WEAPONS  
AND EQUIPMENT

INDEX

RECORD SHEETS

## MOBILE FIELD BASE

**Introduced:** 3059 (Federated Suns, Lyran Commonwealth), 3060 (Coyote)

The mobile field base (MFB) is essentially a self-contained repair gantry equipped with the same welders, grippers and lifting gear incorporated into

a DropShip's 'Mech or vehicle cubicle (but lacking the launch mechanisms and support crew amenities that such facilities include).



### MOBILE FIELD BASE



**Rules Level:** Advanced

**Available To:** CV, SV, MS

**Tech Base (Ratings):** Both (D/X-X-E)

**Game Rules:** An MFB has no effect during combat, but it provides a number of benefits during repair and salvage operations, which are detailed in *Strategic Operations*.

## MOBILE HYPERPULSE GENERATORS

**Introduced:** circa 2655 (Terran Hegemony, Mobile),

circa 2751 (Terran Hegemony, Ground-Mobile)

Hyperpulse generators (HPGs) are the powerful devices the Inner Sphere and Clans universally rely upon for interstellar communications. Essentially capable of "firing" bursts of information through self-created jump points to receivers up to fifty light-years distant, the standard planetary HPG is a familiar sight in known space, consisting of a gigantic antenna dish surrounded by an installation that includes fortified EMP damping architecture,

independent power supplies and large facilities for staff and operators. Far less commonly known are the compact versions, the so-called mobile HPGs.

Produced during the Star League and used heavily by the SLDF, today only the Clans, ComStar and the Word of Blake have access to the 50-ton mobile HPGs used aboard large spacecraft. These groups also reportedly have access to even smaller ground-mobile HPGs, which weigh as little as 12 tons and are designed for transport by ground vehicles or even BattleMechs.

## M-POD

**Introduced:** 3064 (Lyran Alliance)

Based on the A-Pod, the Solaris-designed M-Pod was devised for use against even heavier targets, such as BattleMechs and vehicles. Its short

range and one-shot capability prevented this weapon from being used in a battlefield capacity for years, keeping it in the arenas until very recently.

## MRM "APOLLO" FIRE CONTROL SYSTEM

**Introduced:** 3071 (Draconis Combine)

Billed as the MRM's answer to the Artemis IV, the MRM Fire Control System (currently nicknamed the "Apollo", though the name seems unlikely to stick) helps to overcome the targeting inaccuracies of MRMs without forcing an ammunition upgrade and subsequent redesign of the weapon itself. Instead,

the MRM FCS attaches to the standard MRM launcher and acts as a kind of targeting computer, aligning the weapon for maximum effect. Though the results are far from perfect due to the missiles' own lack of targeting sensors, the result is a greater chance of acquiring the target to begin with.

**Mobile Field Base:** One or more MFBs can be installed in any Combat Vehicle, Support Vehicle or Mobile Structure (DropShips and other applicable units must use the appropriate cubicle bays).

**Mobile Hyperpulse Generators (Mobile HPG/Ground-Mobile HPG):** Mobile HPGs and Ground-Mobile HPGs require a fusion engine in order to operate.

Mobile HPGs may only be installed on Large-sized Support Vehicles, aerospace units over 200 tons in mass and Mobile Structures. Ground-Mobile HPGs can be mounted on 'Mechs, vehicles, fighters, Small Craft, aerospace units over 200 tons and Mobile Structures. 'Mechs mounting Ground-Mobile HPGs can only place this item in torso locations, but may divide the critical slots among adjacent torso sections. Mobile and Ground-Mobile HPGs are treated as energy weapons in game play, and require enough heat sinks to operate if placed on vehicles and other non-heat tracking units.

A unit may carry only one Mobile HPG or Ground-Mobile HPG at a time. Mobile HPGs have a crew requirement of 10. Ground-Mobile HPGs have a crew requirement of 1, which can be the unit's normal operator. Satellites built as unmanned units may include a Ground-Mobile HPG system at no crew requirement, but such HPGs act only as relays and may never change their targeting alignment. Drone units (see p. 305) may not employ HPGs.

Mobile HPGs may not be pod-mounted on Omni-units.

In all other respects, Mobile and Ground-Mobile HPGs may be mounted by any unit in accordance with their standard rules.

**M-Pod:** M-Pods may be mounted in any location (including rear torsos) on a 'Mech or vehicle, or any outer hex of a Mobile Structure, and receive the normal firing arc based on where they are mounted.

**MRM "Apollo" Fire Control System:** The MRM Fire Control System can only be mounted with an MRM system. As with the Artemis IV Fire Control System, the MRM FCS must be incorporated on all of an individual unit's standard MRM Launchers, and non-'Mech units treat MRMs and their fire control systems as a single item for critical space purposes. The aerospace Attack Value of an MRM modified by an MRM Fire Control System is equal to a result of 6 on the appropriate column of the Cluster Hits Table.

**Naval Autocannons (Capital AC):** Naval Autocannons may be mounted on advanced aerospace units per the standard rules for capital-scale weapons covered in *Strategic Operations*. Capital ACs mounted on Mobile Structures follow the rules for those units, presented on p. 267.

## MOBILE HYPERPULSE GENERATORS

**Rules Level:** Advanced

**Available To:** SV, JS, DS, SS, WS, MS (Mobile HPG); BM, IM, CV, SV, CF, AF, SC, JS, DS, SS, WS, MS (Ground-Mobile HPG)

**Tech Base (Ratings):** Both (E/E-X-F [Mobile HPG], F/F-X-F [Ground-Mobile HPG])

**Game Rules:** Mobile HPGs are not given to casual communications. Small vehicles require a substantial time to charge for transmission and the EMP-like effect of transmission and reception can cause difficulties for any unit within range of an outgoing (or incoming) burst.

To activate a Mobile HPG on a Space Station, DropShip, JumpShip or WarShip, the power demands (approximated as heat) amount to 40 points of heat per minute (turn) of transmission. A Ground-Mobile HPG on a Large Support Vehicle generates 20 points of heat per turn when charging or transmitting. For other units, Ground-Mobile HPGs may not be used more than once every 5 turns (in ground combat scale), with 1 turn of charging before being able to transmit for 1 turn; they can only store enough energy for 1 turn of transmission at a time. (In space combat, this entire process occurs in 1 turn.) When sending a transmission (or charging for one), a unit equipped with a Mobile HPG may make no weapon attacks; units equipped with Ground-Mobile HPGs also may not use any MP during a turn in which they are transmitting (but are not considered immobile). Transmission and reception of HPG signals occurs during the Weapon Attack Phase.

The transmission or reception of HPG signals includes an electromagnetic pulse that “blinds” nearby units. The transmission burst from a Mobile HPG temporarily blinds the sensors of the target (or transmitting) vessel and all other units within 1,000 meters (33 ground hexes), while a Ground-Mobile HPG affects the transmitting unit and all others within 250 meters (8 ground hexes). This effect lasts for a period of 1 minute (1 turn in space or high-altitude combat; 6 turns in vehicle-scale ground combat), during which time aerospace units caught within the burst radius cannot make weapon attacks and all non-conventional infantry ground units suffer a +4 to-hit modifier. Receiving bursts—in the rare instances where the pulse is directed at a receiving HPG on a planetary surface—are much less noticeable, and have an area of effect of only 30 meters (1 hex) away from the receiving HPG (regardless of the transmitter type used). If no HPG is available to receive the pulse, no effect occurs.

Mobile HPGs cannot be used to deliver a pulse directly against a target unit other than another HPG.

## M-POD

**Rules Level:** Advanced

**Available To:** BM, IM, CV, SV, MS

**Tech Base (Ratings):** Inner Sphere (C/X-X-E)

**Game Rules:** M-Pods function as an LB-X type Autocannon using Cluster munitions (including the –1 to-hit modifier), but with a range equivalent to a standard machine gun (1 hex for short, 2 for medium, 3 for long, and—if Extreme Range rules are used—4 for extreme). The damage capacity dramatically decreases at each range bracket, however, using the 15 column for Cluster Hits at 1 hex, the 10 column at 2 hexes and the 5 column at 3 hexes. (If Extreme Range rules are used, the M-Pod uses the 2 column for Cluster damage at a range of 4 hexes.) Unexpended M-Pods that take a critical hit explode for 5 points of damage as an ammunition explosion. Expended M-Pods can still be affected by a critical hit in the same way as empty ammo bins.

M-Pods mounted on airborne Airships, Fixed-Wing or Satellite vehicles have no effect in combat.

## MRM “APOLLO” FIRE CONTROL SYSTEM

**Rules Level:** Advanced

**Available To:** BM, IM, CV, SV, AF, CF, SC, JS, DS, SS, WS, MS

**Tech Base (Ratings):** Inner Sphere (D/X-X-E)

**Game Rules:** MRM Fire Control Systems negate the +1 to-hit modifier that applies to all standard MRM launchers. However, on a successful hit, the attacking player must subtract 1 from the roll on the Cluster Hits Table to reflect the inaccuracies of the missiles themselves. MRM Fire Control Systems are treated as an attachment to the MRM launcher, but separate enough so that if they suffer a critical hit, the launcher continues to function per normal MRM rules. The MRM FCS is unaffected by ECMs.

# NAVAL AUTOCANNONS (CAPITAL AC)

**Introduced:** circa 2200 (Terran Alliance)

These behemoth cannons fling single or bursts of kinetic munitions across hundreds of kilometers of space, achieving enormous muzzle velocities using

controlled plasma explosions. Larger naval autocannons trade projectile velocity for mass thanks to engineering limits on the propellant system, which means the heavier naval autocannons have steadily shrinking ranges.

## NAVAL AUTOCANNONS (CAPITAL AC)

**Rules Level:** Advanced

**Available To:** JS, SS, WS, MS

**Tech Base (Ratings):** Both (D/E-X-E)

**Game Rules:** Naval Autocannons use capital-scale range brackets (rather than standard-scale aerospace range brackets) and deliver damage in capital scale as well, every point of which equates to 10 points of standard-scale damage. As with most capital weapons, Naval Autocannons suffer a +5 to-hit modifier against aerospace targets under 500 tons.

INTRODUCTION

ADVANCED  
GROUND MOVEMENT

ADVANCED  
COMBAT

ADVANCED  
BUILDINGS

ADVANCED  
SUPPORT  
VEHICLES

GENERAL  
RULES

ADVANCED  
SUPPORT VEHICLE  
CONSTRUCTION

ADVANCED  
WEAPONS  
AND EQUIPMENT

INDEX

RECORD SHEETS

## NAVAL C<sup>3</sup>

**R&D Start Date:** 3055 (Draconis Combine)

**Prototype Design and Production:** 3065 (Draconis Combine)

An outgrowth of the Combine's C<sup>3</sup> systems, this conceptual super network promises to link WarShip squadrons into finely tuned flotillas with greater coordination and firepower than any equivalent aerospace unit. Combine researchers swiftly found the act of constructing such a large and effective coordination network—capable of linking fire control for massive WarShip-mounted batteries—a lot more daunting than it was for ground forces,

however. Adding in the unusual time delays of aerospace weapons fire and sensor readings presented additional challenges that nearly scrapped the project. Nevertheless, the Nirasaki Computer Collective persevered and was fielding functional, if limited, prototypes in the late 3060s. Regrettably, with few Combine WarShips and DropShips prepared to fully benefit from the technology, the disruption wreaked by the Jihad on the Combine's shipyards left wide deployment of the naval C<sup>3</sup> combat system in limbo.

### NAVAL C<sup>3</sup>

**Rules Level:** Experimental

**Available To:** JS, DS, SS, WS

**Tech Base (Ratings):** Inner Sphere (F/X-X-F)

**Game Rules:** The Naval C<sup>3</sup> system can link up to six Large Craft of 200 tons or more into a coordination network that functions like a ground-based C<sup>3i</sup> system (see p. 133, *TW*), but because of the speeds and distances involved in aerospace combat, the network's effectiveness varies with the weapons employed. The following exceptions therefore apply to Naval C<sup>3</sup> networks:

- The weapon range bracket used (capital or standard) is based on the firing C<sup>3</sup>-networked unit's weapon type, and uses the hex distance of the friendly, networked unit closest to the target to find the range bracket. (For example, if a friendly-networked unit is 10 hexes from the target, it provides a range bracket of short for capital weapons, but medium for standard weapons.) If, however, the attack would take place outside a weapon's normal effective range, the attack still cannot be made.
- Any energy weapons and guided missile weapons (ATMs, LRMs, SRMs and capital missiles) fired by the Naval C<sup>3</sup>-networked unit receive the range modifiers for the most advantageous range bracket to the target from a member of the friendly network.
- All other weapon attacks replace their normal range modifiers with the following: +0 for Short Range, +1 for Medium Range, +2 for Long Range and +4 for Extreme Range.
- The Naval C<sup>3</sup> system is not affected by fighter- and Small Craft-based ECM systems. Large Craft ECM, however, apply modifiers as described in *Strategic Operations*, but do not negate the capabilities of Naval C<sup>3</sup>. For example, suppose that a *Sovetskii Soyuz* and an allied *Vincent* are both using Naval C<sup>3</sup> and that the *Vincent* is 5 hexes from the *Soyuz's* target: an enemy *Aegis* using ECM. Meanwhile, an enemy fighter and an enemy *Union*—both also using ECM—lie directly in the 25-hex line between the *Soyuz* and its prey. The *Soyuz's* NL45s (still within their normal maximum range) would resolve fire as though at Short Range (based on the *Vincent's* range to the target), but would suffer a +3 ECM effect for passing through the *Union* and its bubble of ECM (on hex on either side, plus the *Union's* own hex), and an additional +3 ECM effect from the target *Aegis's* ECM bubble (2 hexes out from the *Aegis*, plus the target WarShip's own hex), for a total modifier of +6. The fighters' ECM would have no impact.
- Aerospace units separated by more than 60 hexes may not operate as part of a Naval C<sup>3</sup> network.

## NAVAL COMM-SCANNER SUITE

**Introduced:** circa 2200 (Terran Alliance)

Using a mobile set of multi-spectral telescopes and processing systems, the Naval Comm-Scanner Suite (NCSS) was developed to passively scan entire solar systems for manmade signals of all sorts. A key element of the Terran Hegemony's electronics intelligence (ELINT) monitoring efforts, naval comm-scanners were used most famously by the Star League's *Bug-Eye* surveillance ship to spy on other nations, both within and beyond the League's borders.

Though powerful, the suite's utility in battle has been overstated in the past. Contrary to popular belief, the only way this system could truly

overhear spoken conversations aboard enemy vessels was if the suite's operators also had friendly operatives on board the target vessel, relaying these conversations through a covert signaling device. Meanwhile, most modern military communications are heavily scrambled, with schemes that cannot often be deciphered by the NCSS alone. Thus, the comm-scanner suite's greatest utility has long been in monitoring communication traffic patterns and civilian communications, or detecting the emissions of modern spacecraft with greater accuracy than standard sensor suites.

**Naval C<sup>3</sup>:** Only DropShips, JumpShips, Space Stations and WarShips over 200 tons in mass may carry a Naval C<sup>3</sup> network. The complex set of fire control servos, sensors and communications arrays occupies tonnage equal to 1 percent of the vessel's total mass, and doubles the weight of any fire control systems present on the vessel. A unit may carry only one Naval C<sup>3</sup> network.

**Naval Comm-Scanner Suite:** An aerospace unit may carry only one Naval Comm-Sensor Suite of any type. The Small NCSS may be installed on any appropriate aerospace unit, and raises the vessel's crew needs by 6. The Large NCSS may not be installed on Small Craft, and any larger unit carrying one requires 12 additional crewmen to operate the system. The first critical hit to the CIC or Sensors on a unit equipped with an NCSS (of either size) disables the system, in addition to the usual effects.

**Naval Gauss (Capital Gauss):** Naval Gauss weapons may be mounted on advanced aerospace units per the standard rules for capital-scale weapons covered in *Strategic Operations*. Naval Gauss weapons mounted on Mobile Structures follow the rules for those units, presented on p. 267.

**Naval Laser (Capital Laser):** Naval Lasers may be mounted on advanced aerospace units per the standard rules for capital-scale weapons covered in *Strategic Operations*. Naval Lasers mounted on Mobile Structures follow the rules for those units, presented on p. 267.

## NAVAL COMM-SCANNER SUITE

**Rules Level:** Advanced

**Available To:** SC, JS, DS, SS, WS

**Tech Base (Ratings):** Both (D/D-E-E)

**Game Rules:** In standard game play, the Naval Comm-Scanner Suite (NCSS) is primarily used to augment a spacecraft's ability to detect other units through Drive Plumes, Emergence Waves, Infrared, Radio Triangulation and Radar sensors. When making checks using such systems per the standard detection rules (as detailed in *Strategic Operations*), a Small NCSS doubles the maximum detection range for all such systems and provides a -1 modifier to the target number to detect a given vessel. A Large NCSS, meanwhile, triples the effective range of all such detection systems and provides a -2 target detection modifier. A +1 modifier applies to these target detection modifiers if the target is a large craft actively using ECM (as detailed in *Strategic Operations*).

In addition, an NCSS of either size provides a +1 initiative modifier in space combat each turn in which the NCSS-equipped unit is in play—though this advantage is negated if the opposing force also possesses an NCSS-equipped unit.

Finally, NCSS-equipped units may also employ these systems to scan a planetary surface, mimicking the functions of a High-Resolution Satellite Imager (see p. 338). Units equipped with a Small NCSS may perform this action if they are within 500 kilometers (28 space map hexes) of a planet surface, while Large NCSS-equipped units may do so from roughly 2,000 kilometers away (111 space map hexes).

## NAVAL GAUSS (CAPITAL GAUSS)

**Introduced:** 2448 (Terran Hegemony)

Even as naval autocannons (NACs) were under development, capital weapons engineers had begun exploring alternative avenues for delivering high-velocity projectiles than the brute-force method of contained laser-ignited plasma (known in some circles as the "Orion in a bottle" technique). Various electromagnetic means of accelerating projectiles—such as coil

guns and rail guns—had been studied during the naval autocannon's development, but remained unsuccessful for centuries because the assorted Gauss techniques ran into engineering barriers. Not until the twenty-fifth century did effective and efficient Gauss technology become feasible as an alternative to naval autocannons, providing ballistic weapons that boasted improved range and heat management capabilities over comparable NACs.

## NAVAL GAUSS (CAPITAL GAUSS)

**Rules Level:** Advanced

**Available To:** JS, SS, WS, MS

**Tech Base (Ratings):** Inner Sphere (E/E-X-E), Clan (E/E-E-E)

**Game Rules:** Naval Gauss weapons use capital-scale range brackets (rather than standard-scale aerospace range brackets) and deliver capital-scale damage, every point of which equates to 10 points of standard-scale damage. As with most capital weapons, Naval Gauss weapons suffer a +5 to-hit modifier against aerospace targets under 500 tons.

Though based on the same technology as ground-based Gauss weapons, Naval Gauss weapons do not cause additional explosive damage if hit in combat (the design of these weapons includes blast-containing features that vent such explosions through the weapon's muzzle and other apertures).

## NAVAL LASER (CAPITAL LASER)

**Introduced:** 2305 (Terran Alliance)

Close on the heels of the naval autocannon's debut came the naval laser. Perfected by Terran engineers, these weapons were the first effective large-scale ranged-energy weapons designed to penetrate the ablative hulls of modern spacecraft.

## NAVAL LASER (CAPITAL LASER)

**Rules Level:** Advanced

**Available To:** JS, SS, WS, MS

**Tech Base (Ratings):** Inner Sphere (D/D-X-E), Clan (D/D-D-E)

**Game Rules:** Naval lasers use capital-scale range brackets (rather than standard-scale aerospace range brackets) and deliver capital-scale damage, every point of which equates to 10 points of standard-scale damage. As with most capital weapons, Naval Lasers suffer a +5 to-hit modifier against aerospace targets under 500 tons.

## NAVAL PPC (CAPITAL PPC)

**Introduced:** 2358 (Terran Hegemony)

While many capital weapons developed as upscaled versions of smaller weapons, the same is not true of capital PPCs and lasers. Engineers found it easier to overcome the technological hurdles of particle beam weapons

against modern armor at larger scales than at smaller scales, and so today's particle projector cannon (PPC) technology first entered service on War-Ships almost a century before the technology was miniaturized effectively enough for ground unit use.

INTRODUCTION

ADVANCED  
GROUND MOVEMENT

ADVANCED  
COMBAT

ADVANCED  
BUILDINGS

ADVANCED  
SUPPORT  
VEHICLES

GENERAL  
RULES

ADVANCED  
SUPPORT VEHICLE  
CONSTRUCTION

ADVANCED  
WEAPONS  
AND EQUIPMENT

INDEX

RECORD SHEETS

## NAVAL PPC (CAPITAL PPC)



**Rules Level:** Advanced

**Available To:** JS, SS, WS, MS

**Tech Base (Ratings):** Inner Sphere (D/D-X-E), Clan (D/D-D-E)

**Game Rules:** Naval PPCs use capital-scale range brackets (rather than standard-scale aerospace range brackets) and deliver capital-scale damage, every point of which equates to 10 points of standard-scale damage. As with most capital weapons, Naval PPCs suffer a +5 to-hit against aerospace targets under 500 tons.

## NAVAL REPAIR FACILITIES

Within a few decades of the dawn of spaceflight, humankind was building spacecraft larger than could be launched from Terra by a single vessel. Unlike the spacecraft of the mid-twentieth century, twenty-first century spacecraft such as the *Altair*-class interplanetary vessels were not

expedient and required maintenance. The need for in-orbit assembly and maintenance quickly led to the development of pressurized and unpressurized repair facilities.

### STANDARD REPAIR FACILITIES (PRESSURIZED/UNPRESSURIZED)

**Introduced:** Early spaceflight

The first unpressurized space naval repair bays (and their somewhat smaller, pressurized equivalents) became operational on the Crippen space station in the year 2007. These facilities hosted a number of groundbreaking spacecraft, among them the first manned interplanetary spacecraft (including the *Altair*-class spacecraft that journeyed from Terra to its in-system neighbor world of Mars, and the *Columbia*, humankind's first fusion-powered manned spacecraft), and even supported assembly of the *Magellan*-class slower-than-light interstellar probes.

Repair bays—whether pressurized or not—share many features in common, including a collapsible framework that can be used to aid in repair operations for any ship small enough to fit within the frame. Unpressurized facilities are most common and weight efficient for the station or vessel using them, but pressurized bays, which include an outer shell that can be filled with breathable air, also exist. These pressurized facilities, while heavier and bulkier, nevertheless offer work crews greater ease of operation and improved repair efficiency that can decrease a vessel's downtime.

### REINFORCED REPAIR FACILITIES (UNPRESSURIZED)

**R&D Start Date:** circa 2725 (Terran Hegemony)

**Prototype Design and Production:** circa 2750 (Terran Hegemony), circa 3065 (Word of Blake)

The reinforced repair facility effectively utilizes a variation of typical naval tug design standards and combines them with the spidery, delicate framework of a standard unpressurized repair facility frame. The result is a repair facility structure that, while limited to airless design and operations,

can nonetheless withstand the stress of maneuvering while another unit remains docked within the frame.

Initially researched by the Terran Hegemony during the latter days of the first Star League, design and research into making this "repair tug" frame useful lagged behind many other SLDF projects. The Word of Blake, however, has reportedly managed to revive and complete prototype development for this technology, possibly to address the dangers of servicing their far-flung forces.

## NAVAL TUG ADAPTOR

**Introduced:** Early spaceflight

The first spaceborne tugs were specially built chemical- and ion-powered craft used to help move and join the various modules of Crippen Station—the linchpin of the Western Orbital Defense Network (WODeN). Though space-

craft have grown more sophisticated since those days, the basic premise and engineering of today's space tugs have barely varied. The reinforced structure and mating clamps used in the early twenty-first century designs are much the same as those used on salvage vessels like the Model 97 *Octopus*.

**Naval PPC (Capital PPC):** Naval PPCs may be mounted on advanced aerospace units per the standard rules for capital-scale weapons covered in *Strategic Operations*. Capital PPCs mounted on Mobile Structures follow the rules for those units, presented on p. 267.

**Naval Repair Facilities:** Space Stations can be constructed with one or more Naval Repair Facilities, each of which requires an assigned facing (a maximum of 1 repair facility per facing applies). WarShips and JumpShips can mount only one repair facility (which also requires an assigned facing). Each repair facility mounted on a unit reduces its maximum number of DropShip docking collars by the facility's tonnage capacity, divided by 50,000 (rounded up to the nearest whole). For example, a WarShip that mounts a repair facility with a maximum capacity of 280,000 tons would sacrifice 6 potential docking collars to do so ( $280,000 \text{ tons capacity} \div 50,000 = 5.6$ , rounded up to 6). These docking collars are effectively integrated into the repair frame, reflecting access gantries that service crews use during repair operations. Full rules on constructing the units that use this item will appear in *Strategic Operations*.

Regardless of the type chosen, the weight a Naval Repair Facility requires is based on the facility's maximum capacity (in tons). Standard pressurized facilities weigh 7.5 percent of their maximum capacity; standard unpressurized facilities weigh 2.5 percent of their maximum capacity. A Reinforced Repair Facility (available only as an unpressurized facility) weighs 10 percent of its maximum capacity. The tonnage for a repair facility of any type must be rounded up to the nearest full ton.

One or more bay doors must be designated as serving a repair facility during construction.

**Naval Tug Adaptor:** A Naval Tug Adaptor weighs 100 tons. However, the additional reinforcements needed add 10 percent of the tug's total mass to its Structural Integrity weight (without increasing the SI value).

## STANDARD REPAIR FACILITIES (PRESSURIZED/UNPRESSURIZED)

**Rules Level:** Advanced

**Available To:** JS, SS, WS

**Tech Base (Ratings):** Both (C/C-E-D)

**Game Rules:** Standard Naval Repair Facilities may accommodate up to 1 JumpShip, Space Station or WarShip; 2 DropShips; or any number of satellites, Small Craft or fighters (so long as the total weight of the stored unit[s] does not exceed the repair bay's maximum rated capacity in tons). Repair facilities have no direct effect during combat, but they provide a number of benefits during repair and salvage operations, which are covered in *Strategic Operations*. Facilities can accommodate docked aerospace units with a combined weight up to the facilities' maximum capacity and can be pressurized or unpressurized. Pressurized facilities allow personnel to work without the encumbrance of bulky life support gear.

WarShip-mounted repair facilities (pressurized or otherwise) prevent their vessels from using any Thrust beyond station-keeping while another vessel is within the repair frame. Any attempt to do so automatically results in the docked unit(s) ramming the mother ship within which it is contained, with damage bypassing the armor and being applied directly to the repair facility ship's structural integrity.

Furthermore, a JumpShip or WarShip may not jump when its repair facilities contain other vessels that possess a K-F drive core (even one that is damaged). If a repair facilities-equipped JumpShip attempts to do so (or the vessels docked within said facilities attempt to do so), both vessels are automatically destroyed. JumpShips or WarShips with repair facilities may jump while the facilities contain non-jump capable vessels, however, as these systems incorporate K-F drive booms.

Any critical hit to a vessel with a repair facility that strikes a Weapon Bay in the facility's assigned facing arc results in damage to any docked units stored within. This damage is equal to half that of the weapon that inflicted the critical hit, divided evenly between all docked units within the repair bay, but the weapon does not automatically receive another chance to inflict critical hits against the docked targets. Assume that any units within the facilities share the same orientation as their mothership when determining the hit location table to be used.

## REINFORCED REPAIR FACILITIES (UNPRESSURIZED)

**Rules Level:** Experimental

**Available To:** JS, WS

**Tech Base (Ratings):** Inner Sphere (C/F-X-F)

**Game Rules:** Reinforced Repair Facilities follow the same repair rules as their standard unpressurized equivalents referenced above, except that the vessel equipped with such facilities is not limited to station-keeping Thrust only when it has another craft docked within. Instead, the repair ship receives a modified Thrust Rating as if it were a tug of equivalent weight (see *Naval Tug Adaptor*, pp. 334–335).

## NAVAL TUG ADAPTOR

**Rules Level:** Advanced

**Available To:** SC, DS, WS

**Tech Base (Ratings):** Both (C/C-C-C)

**Game Rules:** Naval tug operations may only be performed in space; naval tugs that enter an atmosphere while linked to another vessel automatically go out of control.

A unit equipped with a Naval Tug Adaptor (known as the tug) must dock with its target vessel in order to use it, and may not do so if the target vessel is actively resisting efforts to mate with the tug (by expending Thrust Points). To establish the connection, the tug must end its movement in the same hex as the target vessel and match the target vessel's facing and velocity. In the following turn, in place of movement, the tug must then make a successful Control roll, applying +5 modifier if the target vessel or the tug is out of control. If the roll succeeds, in the following turn both the tug and the target vessel are linked up and the tug has "control" over the target vessel's flight. If the roll fails, the tug sustains 2 points of standard-scale damage for every point by which the Control roll failed, and an equal amount of damage is applied to the aft of the target vessel.

A Small Craft tug may only attempt to tug an Aerospace Fighter, Small Craft or Satellite Support Vehicle. DropShip and WarShip tugs may mate with units of any weight above 200 tons. (DropShips and WarShips attempting to "tug" smaller aerospace units should instead use the rules for recovering fighters; see p. 86, *TW*.)

Once mated, neither the tug nor a unit docked with it may engage in combat, though other aerospace units may target both vessels normally. If a tug receives damage to its Sensors or Control systems through the Nose arc, or the target vessel attempts to use Thrust points while mated to a tug, the tug mechanisms are damaged; both the tug and its target vessel go out of control and must immediately check for a collision against each other per standard rules (see pp. 92–93, *TW*).

Once successfully mated to a target vessel, the Thrust values for the tug, which now has control of the pair, are then recomputed as follows:

First, multiply the tug's Safe Thrust Rating by its tonnage; the product is the tug's Safe Thrust Tonnage.

Second, add together the tonnage of the tug and its target vessel. This value is the Total Mass.

Third, divide the Total Mass by the tug's Safe Thrust Tonnage to find the Safe Towed Thrust Ratio. Divide the tug's Safe Thrust by the Safe Towed Thrust Ratio to find the tug's Safe Towed Thrust Rating. Multiply this value by 1.5 to find the Maximum Towed Thrust Rating, the maximum thrust the tug can generate for both joined vessels together. Round both values up to the nearest quarter (0.25) Thrust point. A tug may use some or all of its Towed Thrust when towing a target, including airship-like fractional Thrust points (see pp. 204–205, *TW*).

Tug fuel consumption is based on the Thrust being used. To determine the Thrust spent per turn of towing another unit, multiply the Towed Thrust Points expended by the Safe Towed Thrust Ratio.

INTRODUCTION

ADVANCED  
GROUND MOVEMENT

ADVANCED  
COMBAT

ADVANCED  
BUILDINGS

ADVANCED  
SUPPORT  
VEHICLES

GENERAL  
RULES

ADVANCED  
SUPPORT VEHICLE  
CONSTRUCTION

ADVANCED  
WEAPONS  
AND EQUIPMENT

INDEX

RECORD SHEETS

# NULL-SIGNATURE SYSTEM

**Introduced:** 2630 (Terran Hegemony)

**Extinct:** 2790 (Inner Sphere)

Created by the first Star League, the null-signature system is an elaborate series of passive and active electronic countermeasures and heat baffles

that combine to mask a BattleMech's heat and electromagnetic signature. Similar to the modern, Capellan-made stealth armor system that derives from it, the null-signature system is somewhat more sophisticated, and does not require the use of a separate ECM unit to attain its capabilities.

## NULL-SIGNATURE SYSTEM

**Rules Level:** Experimental

**Available To:** BM

**Tech Base (Ratings):** Inner Sphere (E/E-X-X)

**Game Rules:** A unit with a Null-Signature System may activate or deactivate the system during the End Phase of any turn, or even start the game with the system already engaged. While the Null-Signature System is engaged, attacks against the unit at Medium range receive an additional +1 to-hit modifier, while attacks at Long and Extreme Range receive an additional +2 to-hit modifier. Beagle Active Probes and their Clan equivalents cannot locate a hidden unit with an active Null-Signature System, and heat-seeking weapons (such as Heat-Seeking Missiles) calculate their to-hit modifiers against the unit as though it is 8 points cooler than it actually is. Only a Bloodhound Active Probe (see p. 278) can penetrate the Null-Signature System's masking. Conventional infantry units are unaffected by the Null-Signature System and ignore these modifiers.

A critical hit to any of the Null-Signature System's critical slots (or the destruction of any hit location containing one) disables the entire system.

While active, the system generates 10 points of heat. If used in conjunction with an active Chameleon Light Polarization Shield (see p. 300), all modifiers are cumulative.

# POWER COLLECTOR AND MICROWAVE TRANSMITTER

**Introduced:** circa 2200 (Terran Alliance)

For a brief window in the early twenty-first century, humankind experimented with solar-power satellites. Though the test platforms were successful, the Western Alliance made little progress toward constructing the final behemoth-sized, city-powering satellites they had envisioned when the sudden development of fusion power in the 2020s rendered such efforts obsolete. In later centuries, interstellar nations like the Taurian Concordat, Capellan Confederation and even the Federated Suns would find niche applications for small power satellites, as much for industrial usage as for political control (such as the centralized power distribution networks favored by House Liao on many worlds). Today, the technology is well understood and broadly available, but still quite rare in general use.

Despite the popularized account of the rare "high density" PCMT over Kathil (used to dramatic effect in the Fourth Succession War), by far the majority of

the PCMTs used today are exceedingly safe "low density" models. A common failsafe feature is that the physics of the transmitters means the transmission becomes harmlessly diffuse (more so than normal) when the beam drifts away from its collector facility. This arrangement is referred to as a retro-directive phased array, where the satellite requires a transmitted "pilot beam" to focus on, and so its beam loses cohesion when no longer aimed at its pilot beam.

PCMTs are normally placed in synchronous orbits, which are generally in near-continuous sunlight and thus deliver power continuously. An associated power storage system on the ground (pumped hydroelectric, compressed air, advanced batteries and so on) carries the load during the brief blackouts (typically occurring near solstices). Planets without suitable synchronous orbits must use several PowerSats (or supplement PowerSats with other power sources) to provide continuous power.

**Null-Signature System:** The Null-Signature System does not weigh a significant amount, but takes up 1 critical slot in each of the BattleMech's locations except the head.

A Mech with this system may not mount advanced targeting computers, C<sup>3</sup> systems, Stealth Armor, or a Void-Signature System. The unit may carry an active probe, TAG or ECM Suite, but unlike Stealth Armor, the Null-Signature System does not require an ECM Suite.

The Null-Signature System cannot be installed on an OmniMech via OmniPods.

**Power Collector and Microwave Transmitter (PCMT), Low-Density:** PCMT equipment include solar power collection and transmission equipment. Every 10 tons of PCMT (round fractions down) can provide enough power to a suitably equipped receiver facility to supply a day's worth of the electrical needs for 5 average-sized buildings (each 1 hex across, 3 hexes tall). The enormous transmission antennas and solar arrays required by PCMT systems may not be mounted in any unit other than Satellite Support Vehicles and Space Stations.

The reception equipment for low-density PCMTs generally measures several kilometers across (typically represented in game play as a light or medium non-mobile building), and thus constitutes an item of utility infrastructure beyond the scope of these rules.

**PPC Capacitor:** PPC Capacitors may be added to any Inner Sphere standard-scale PPC weapon (including Light PPCs, Heavy PPCs, ER PPCs and Snub-Nosed PPCs, but not counting Naval PPCs of any size, or particle cannon weapons carried by infantry units).

The PPC Capacitor weighs 1 ton and occupies 1 critical slot, which must be placed in the same location as the PPC it modifies. Capacitors can only modify one PPC and do not stack. For Combat Vehicles and aerospace units, the Capacitor is considered integral to the PPC it modifies and only adds tonnage to the weapon. As PPC Capacitors increase the attached PPC's heat by 5 points, vehicles and Conventional Fighters must account for this added heat when determining their heat sink needs.

If the unit also carries a Targeting Computer, the weight of any PPC Capacitors it carries has no impact on the computer's size or tonnage.

**ProtoMech Melee Weapon:** A ProtoMech melee weapon weighs one half-ton and takes up one weapon slot on either arm. A ProtoMech may only mount one melee weapon.

**Recon Camera:** The Recon Camera may be mounted on any applicable unit in accordance with that unit's rules for mounting weaponry. However, as a non-weapon item, the Recon Camera requires no ammunition, power amplifiers or heat sinks to operate.

## POWER COLLECTOR AND MICROWAVE TRANSMITTER (PCMT), LOW-DENSITY

**Rules Level:** Advanced

**Available To:** SV, SS

**Tech Base (Ratings):** Both (C/C-C-C)

**Game Rules:** “Low density” PCMTs—by far the most commonly used of the two—are incapable of causing harm or otherwise affecting game play. “High density” PCMTs—so rare that only one or two examples still exist in the thirty-first century—are beyond the scope of these rules.

In addition to being damaged as a normal item of equipment, if the engine or station-keeping drive of the unit mounting a PCMT is destroyed, the PCMT is also considered destroyed.

## PPC CAPACITOR

**R&D Start Date:** 3057 (Draconis Combine)

**Prototype Design and Production:** 3060 (Draconis Combine)

The advent of newer PPC types sparked a renewed interest in the experimental PPC capacitor technologies being developed by various Inner Sphere

researchers in the 3050s and 3060s. Because the newer PPCs did not differ much from the standard or ER models already in use, designers quickly realized that extant PPC capacitor technologies applied equally well to the newer weapons, expanding on the utility of this experimental technology by the early 3070s.

### PPC CAPACITOR

**Rules Level:** Experimental

**Available To:** BM, IM, CV, SV, AF, CF, SC, JS, DS, SS, WS, MS

**Tech Base (Ratings):** Inner Sphere (E/X-X-E)

**Game Rules:** Instead of firing a PPC as normal, the pilot may choose to charge the PPC Capacitor, building up 5 points of heat. This charge can be held as long as needed, during which time the charged Capacitor continues to generate 5 points of heat. When the charged PPC is finally fired, the release of the charge builds up an additional 5 points of heat, in addition to the heat from the weapon itself. (Thus, if a ‘Mech with an ER PPC with a Capacitor charges the weapon in Turn 1 but does not fire it until Turn 4, it would generate 5 points of heat from the charging Capacitor for Turns 1 through 3 [due to the Capacitor], and 20 points in Turn 4 when it fires [15 for the ER PPC, plus 5 for the Capacitor’s charge release].)

A PPC fired with an attached PPC Capacitor that is charged adds 5 points to its normal damage value.

Much like a Gauss rifle, a PPC Capacitor explodes if it or its attached PPC suffer a critical hit while charged, resulting in an internal explosion equal to the full combined maximum damage value of the PPC and its capacitor. The explosion also destroys all critical slots for both the PPC and its capacitor. If the PPC was (or is being) fired during the same Attack Phase in which such a critical hit occurs, the weapon is considered to have discharged before the critical hit, and the critical hit simply destroys the affected slot with no explosive effects.

A to-hit roll result of 2 with a capacitor-charged PPC burns out the system before it can fire, damaging the capacitor slot as well as the first critical slot of the corresponding weapon, but inflicting no damage against the target.

## PROTOMECH MELEE WEAPON

**R&D Start Date:** 3066 (Clan Blood Spirit)

**Prototype Design and Production:** 3067 (Clan Blood Spirit)

Due more to aesthetics than any real combat value, some ProtoMech pilots have begun insisting on mounting melee-style weapons to augment a ProtoMech’s physical combat capability. While a variety of such weapon

styles now exist, the only practical difference between them is their look; none of them give any particular edge over the others to the ProtoMech in close combat situations, and so such weapons have become as much a piece of flair to express the ProtoMech warrior’s personality as a means to inflict damage on an enemy in a melee.

### PROTOMECH MELEE WEAPON

**Rules Level:** Experimental

**Available To:** PM

**Tech Base (Ratings):** Clan (C/X-X-E)

**Game Rules:** When executing a ProtoMech “frenzy” attack (see p. 187, *TW*), a ProtoMech’s melee weapon adds 1 point of damage for every 5 tons of ProtoMech weight (or fraction thereof)—regardless of the weapon’s style. If the arm carrying a ProtoMech melee weapon is destroyed or the weapon’s slot suffers a critical hit, the melee weapon ceases to function.

## RECON CAMERA

**Introduced:** Pre-spaceflight

A modern rendition of centuries-old technology, the recon camera is a battlefield surveillance item rarely seen in the modern age, yet useful nonetheless. Most commonly employed by low-tech reconnaissance planes

like the Boomerang, or even by civilian newsvid VTOLs, the recon camera system is actually a group of multiple visual sensors that can provide high-resolution holographic data on a section of terrain overflowed by the user.

## RECON CAMERA



**Rules Level:** Advanced

**Available To:** BM, IM, PM, CV, SV, AF, CF, SC, MS

**Tech Base (Ratings):** Both (C/B-B-B)

**Game Rules:** The Recon Camera has limited visual range (18 kilometers at best), and so is useful only in Low Altitude operations over the mapsheet (or on it). A unit with a Recon Camera can use it to act as a spotter for LRM Indirect Fire (see p. 111, *TW*) as if it were a TAG (see p. 142, *TW*), but cannot use it to designate targets for other TAG-guided weapons, such as semi-guided LRMs, laser-guided bombs and Arrow IV artillery missiles. Furthermore, in any turn where an airborne Recon Camera passes over a hex containing a hidden unit hostile to the camera unit's force, the hidden unit's controlling player must roll 2D6 and reveal the position of the unit on a result of 9+.

## RIFLE (CANNON)

**Introduced:** Pre-spaceflight

A weapon system harkening back to the early twentieth century, vehicle-scale rifles (or cannons) were either rifled- or smooth-bore weapons designed with lower reloading and firing rates compared to even the smallest standard autocannons of today. Relying more on larger-caliber rounds and greater concentrations of propellant to deliver their damage, these

weapons were developed by various Inner Sphere and Periphery manufacturers for centuries before the autocannon rendered them obsolete. Today, very few are produced in the Inner Sphere (where they are often lumped into the category of retro-tech), while the Clans have abandoned these weapons entirely.

## RIFLE (CANNON)



**Rules Level:** Experimental

**Available To:** BM, IM, CV, SV, AF, CF, SC, DS, MS

**Tech Base (Ratings):** Inner Sphere (B/C-F-X)

**Game Rules:** Rifles lack the power to function effectively at normal space-to-space ranges, but may be employed by aerospace units operating in atmosphere and their ground-based counterparts, where they function as normal direct-fire ballistic weapons. However, because they lack the armor-penetrating power of modern autocannons, rifles of all sizes must subtract 3 points of damage (to a minimum of 0) for successful attacks against any unit except for conventional infantry, battle armor, 'Mechs using Commercial Armor, or Support Vehicles with a BAR rating below 8.

## SATELLITE IMAGERS

Handy equipment employed by satellites since practically the dawn of spaceflight, satellite imagers are specialized orbit-to-surface cameras that have been used through the centuries to monitor everything from planetary weather and pollution patterns to troop movements and even—under more insidious circumstances—the activities of common folk living under less

trusting rulers. The most common imager types seen today perform many of these tasks over almost every civilized world in the Inner Sphere and Clan space. Despite their collective name, satellite imagers may be employed by other spacecraft as well.

### HIGH-RESOLUTION (HI-RES) IMAGER

**Introduced:** Early spaceflight

The high-resolution (Hi-Res) imager is effectively a sophisticated holographic and photographic array capable of distinguishing objects down

to a meter in size from orbit. Used in the civilian sector to monitor cloud patterns, and in the military to watch troop movements, these imagers are limited in each mode by local weather conditions and darkness.

### HYPERSPECTRAL IMAGER

**Introduced:** ca. 3055 (Federated Commonwealth)

A more sophisticated variation on the Hi-Res imager, the hyperspectral imager adds electromagnetic and thermal sensors for a more comprehen-

sive sweep of the target area. This enables it to spot camouflaged units that a Hi-Res imager might miss.

**Rifle (Cannon):** Rifles of any size may be mounted on any applicable unit in accordance with that unit's rules for mounting weaponry. Rifles are compatible with targeting computers.

Rifles use only standard munitions, which must be installed in full-ton lots.

**Satellite Imagers:** Satellite Imagers may only be mounted on airborne unit types (including VTOLs, Fixed-Wing, Airship and Satellite Support Vehicles, fighters, Small Craft, other spacecraft and airborne Mobile Structures). On all such units, imagers are mounted as a standard-scale weapon and may be placed in any standard weapon bay, but have no damage or heat values, nor do they affect the weight of targeting computers, crew and the like. Imagers must be assigned a "firing arc" appropriate to their mounted location.

## SATELLITE IMAGERS

**Rules Level (General):** Advanced

**Available To (General):** CV, SV, AF, CF, SC, JS, DS, SS, WS, MS

**Game Rules (General):** Satellite Imagers of all types have a maximum effective sensor range of 30 hexes on the Space or the High-Altitude Map. Imagers used exclusively in space to detect other spaceborne targets provide no significant impact in game play beyond identifying a unit and assessing its condition. However, when an imager is available and focused on a ground battlefield, it can provide bonuses to any force able to access the imager's feed.

Aerospace units and manned satellites equipped with imagers can automatically provide these bonuses to friendly ground forces that include at least one unit with a minimum of 4 tons' worth of manned Communications Equipment. Hostile or neutral units carrying imagers and unmanned units with imagers may be "hacked" for these same benefits by any unit with a minimum of 5 tons' worth of manned Communications Equipment—regardless of the hacking unit's affiliation—on a successful 2D6 roll of 9+ (11+, if the imager is on a hostile unit). To perform this hack, however, the unit may make no Weapon Attacks in that turn, and any benefits obtained from the satellite feed will begin in the following turn.

Units with multiple Satellite Imagers provide all the features of each imager concurrently, but do not stack any Initiative modifiers they provide. Initiative modifiers provided by Satellite Imagers are negated if opposing sides successfully access the same imager type. Hacking a unit with imagers only provides the bonuses of the imager system(s) on the hacked unit, with the same effects as noted above.

Critical hits to a Satellite Imager, or to the Communications Equipment of a receiving unit, the destruction of either the imager unit or its receiver, and any ECM effects (including those of friendly systems; Satellite Imagers are not as sophisticated as military C<sup>3</sup> equipment) between the imager and any receivers automatically disable the link and negate all bonuses provided by the imager's use. If the imager was hacked to attain this link, the connection is lost for the remainder of the scenario; otherwise, the connection can be re-established after (or if) the interference clears.

## HIGH-RESOLUTION (HI-RES) IMAGER

**Tech Base (Ratings):** Both (C/D-E-D)

**Game Rules:** The High-Resolution Imager provides its bonuses only if the target battlefield is in daylight and the local weather is clear, overcast or vacuum. This imager then provides a +1 initiative modifier for the friendly receiving unit's force as long as the connection is maintained. Furthermore, if the Hi-Res Imager is accessed during the Weapon Attack Phase of the first turn of game play (or prior to the start of play), it also forces the controlling player of any hostile units to roll 2D6 for each hidden unit on the battlefield, revealing the unit on any result of 8+ unless the unit is equipped with active Mimetic Armor, a Chameleon Light Polarization Shield, Void-Signature System, or other camouflage. This imager also may not detect units located underwater, within a building, within heavy or ultra-heavy woods, within any jungle hex, within a smoke-filled hex or underground.

## HYPERSPECTRAL IMAGER

**Tech Base (Ratings):** Inner Sphere (D/X-X-F)

**Game Rules:** The Hyperspectral Imager provides its bonuses only if the local weather over the target battlefield is clear, foggy, overcast or vacuum. This imager then provides a +1 initiative modifier for the friendly receiving unit's force as long as the connection is maintained. Furthermore, if the Hyperspectral Imager is accessed during the Weapon Attack Phase of the first turn of game play (or prior to the start of play), it also forces the controlling player of any hostile units to roll 2D6 for each hidden unit on the battlefield, revealing the unit on any result of 7+ unless the unit is using a Null-Signature, Void-Signature, or Stealth Armor System. This imager also will not detect units located under more than 1 depth of water, within a building, within ultra-heavy woods or heavy/ultra-heavy jungle, within a smoke-filled hex or underground.

## INFRARED IMAGER

**Introduced:** Early spaceflight

A specialized imager type, the infrared imager is most commonly used in nighttime surveillance or under low-visibility conditions, as it relies on tracking heat rather than visual signals.

## INFRARED IMAGER

**Tech Base (Ratings):** Both (C/D-E-D)

**Game Rules:** The Infrared Imager provides its bonuses only if the local weather over the target battlefield is clear, foggy, overcast, cloudy, rainy, snowy or vacuum. This imager then provides a +1 initiative modifier for the friendly receiving unit's force as long as the connection is maintained. Furthermore, if the Infrared Imager is accessed during the Weapon Attack Phase of the first turn of game play (or prior to the start of play), it also forces the controlling player of any hostile units to roll 2D6 for each hidden unit on the battlefield, revealing the unit on any result of 8+ unless the unit shutdown without an overheat level, or is actively using a Null-Signature, Void-Signature, or Stealth Armor System. Infrared Imagers also will not detect units located under more than 3 depths of water, within an ultra-heavy jungle hex, within a building of CF 70 or greater, or underground.

INTRODUCTION

ADVANCED  
GROUND MOVEMENT

ADVANCED  
COMBAT

ADVANCED  
BUILDINGS

ADVANCED  
SUPPORT  
VEHICLES

GENERAL  
RULES

ADVANCED  
SUPPORT VEHICLE  
CONSTRUCTION

ADVANCED  
WEAPONS  
AND EQUIPMENT

INDEX

RECORD SHEETS

## LOOK-DOWN RADAR

**Introduced:** Early spaceflight

Often used as a satellite imager, but also common on aircraft and fighters, look-down radar is an active sensor system that relies on radio signals

to map the ground below, picking out targets as anomalies in the terrain contours. However, this system remains susceptible to ECM jamming and similar effects.

## LOOK-DOWN RADAR



**Tech Base (Ratings):** Both (B/D-E-D)

**Game Rules:** Look-Down Radar provides its bonuses only if the local weather over the target battlefield is clear, foggy, overcast, cloudy, rainy, snowy or vacuum. This item then provides a +1 initiative modifier for the friendly receiving unit's force as long as the connection is maintained. Furthermore, if Look-Down Radar is accessed during the Weapon Attack Phase of the first turn of game play (or prior to the start of play), it also forces the controlling player of any hostile units to roll 2D6 for each hidden unit on the battlefield, revealing any non-infantry unit on a result of 8+ unless the unit mounts an active ECM, Null-Signature System, Void-Signature System, or Stealth Armor of any kind (excepting visual camouflage systems). Infantry units and units located underwater, within heavy or ultra-heavy woods or jungle hexes, within a building or underground are also immune to Look-Down Radar detection.

## SPECIALIZED INFANTRY

**Introduced:** Pre-spaceflight

Since mankind first created warfare, it immediately began creating specialized infantry dedicated to mission specific combat roles. Mountain troops to SCUBA, these specially-trained troops bring expertise to a wide

variety of situations. However, it is the combat engineer and all its sub-specialties that still remain one of the most important components of any military command. From minesweepers to bridge builders, demotions to fieldworks; specialized infantry are the true workhorse of any campaign.

## SPECIALIZED INFANTRY



**Rules Level:** Advanced

**Available To:** CI

**Tech Base (Ratings):** Both (Various)

**Game Rules:** As summarized by the Specialized Infantry Types Table below, each Specialized Infantry type imposes varying effects on the maximum troops per squad (Max Squad), maximum platoon size (Max Platoon), maximum number of support weapons per quad (Max Secondary Weapons), movement (MP), transport weight (Added Tons) and terrain restrictions (Prohibited Terrain). Additional rules for each specialized platoon type apply as follows:

**Combat Engineers:** These troops can perform a variety of tasks in the field, which must be designated before the start of the scenario.

• **Bridge-Building Engineers:** These troops carry assembly parts and tools for their operation, and can raise 2 single-hex Light Bridges or 1 single-hex Medium Bridge per scenario by spending 6 full turns adjacent to a target hex and engaging in no other actions or taking damage while doing so. A Light Bridge built by these infantry receives a CF of 15, while a Medium Bridge receives a CF of 40 (double these values if the bridge is built over water). If a Bridge-Building unit suffers any damage during a turn when it is attempting to build a bridge, the building effort extends by 1 turn (regardless of how many times the unit is attacked). If a Bridge-Building unit is destroyed before completing its task, the bridge is destroyed as well.

**Specialized Infantry:** All Specialized Infantry must be of Veteran experience or greater. When constructing a Specialized Infantry platoon, the designer may select one or more specializations from the Specialized Infantry Table, but must apply the most restrictive values for each of the platoon specialty types. All troops within a Specialized Infantry unit must have the same specialization(s). Furthermore, Specialized Infantry construction modifies the standard Conventional Infantry Construction rules (see pp. 144-155, *TM*) as follows:

The *Max Squad (Troops)* value for the specialist unit sets the maximum number of troops per squad, but based on the Tech Base (Affiliation) chosen, this figure may be revised per the standard Conventional Infantry rules (see p. 141, *TM*).

The *Max Platoon (Troops/Squads)* values set the maximum platoon size in actual troops (left of the slash) and squads (right of slash). Even if it meets the maximum listed number of squads per platoon, the number of actual troopers in a specialist platoon may not exceed the maximum troop numbers per platoon without breaking the unit into "sub-platoons" per the Oversized Platoons rule (see p. 146, *TM*).

The *Max Secondary Weapons* value sets the maximum number of secondary weapons that may be chosen per squad of specialist infantry. As with standard infantry platoons, a specialized platoon suffers the same movement restrictions as dictated by their chosen Motive Type for the number of support-type secondary weapons chosen.

The *MP (Type)* values establish the number of MPs and their type that specialized infantry use in game play. For Combat Engineers and Marines, this can vary with the unit's chosen Motive Type, while Mountain Troops and Paratroops are restricted to a basic Foot Motive Type (modified for their special abilities per the game play rules above), and SCUBA units use submarine movement (as modified by the special abilities rules above).

The *Added Tons* value establishes additional weight over and above the infantry unit's Motive Type (see p. 155, *TM*). For Combat Engineers and Marines, the base per-trooper weight varies with the Motive Type chosen (0.1 ton for Foot, 0.21 for Motorized, 0.18 for Jump, 1 for Hover/Tracked/Wheeled Mechanized, 1.5 for Microlite VTOL and 2 for Microcopter VTOL), while other specializations presume a base weight of 0.1 ton per trooper. For all applied specializations, the value in this column must be added to this weight to find the total per-trooper weight for unit transport purposes. For example, a Motorized Marine Combat Engineer has a per-trooper weight of 0.21 (Motorized) + 0 (Marine) + 0.1 (Combat Engineer) tons, or 0.31 tons for each trooper.

The *Tech Ratings* values are used to determine the Tech level and Availability of the various infantry specialty types.

The unit's *Prohibited Terrain* is also established for game play purposes. In all cases, the narrowest terrain restrictions apply between the unit's chosen Motive Type and Specialty.

**Paramedics:** Unlike the other specialty infantry types, paramedics are special troops who can replace one, some, or all of the platoon's ordinary secondary weapons troopers (regardless of platoon type). Paramedics carry no weapons, and provide no damage value in combat. As long as a platoon can carry secondary weapons, it can trade one secondary weapon trooper for one paramedic. Any leftover secondary weapons troopers in the platoon can use secondary weapons per the normal construction rules. However, special weapon effects dependent on the number of troopers per squad—such as Heavy Burst Fire—will be affected by any reductions. (For example, in a conventional motorized machine gun platoon of 28 troops, there are 8 secondary troopers—those carrying the machine guns. The designer can choose to designate 1 to 8 of these troops as paramedics instead, while the remainder may still carry their machine guns, but at a cost of the Heavy Burst feature that requires a minimum of 2 troopers per squad to receive.)

## SPECIALIZED INFANTRY (CONT)

• **Demolition Engineers:** These troops plant explosive charges on structures such as bridges and buildings. While setting charges, a Demolition Engineer platoon may not engage in any other movement or combat actions. The damage these charges inflict (on the target structure only) is determined by multiplying the number of turns the platoon spends in the target hex setting them (to a maximum of 6 turns), times the number of damage points listed for an SRM infantry platoon of equivalent numbers (as of when the platoon ceases planting the charges). Once finished setting their charges (announced at the End Phase of the turn), the demolition platoon's controlling player may announce, during any subsequent End Phase, that he is detonating the charges, inflicting the computed damage only against to the hex worth of the structure the platoon spent its turns rigging up. While the charges will not directly damage any other units in the same hex, any damage from the collapsing structure will (see pp. 177-178, *TW*).

• **Firefighting Engineers:** Firefighters carry portable fire suppression gear, ranging from simple compressed water hoses to flame-retardant foams, and may fire these at a single burning adjacent hex (or unit) in place of a weapon attack. The attack automatically hits, but then the controlling player must roll 2D6, subtracting 2 from the roll result if the fire was started by any type of Inferno munition or fuel-fed flamers (such as Vehicular Flamers). On a result of 8+, the target fire is extinguished. (Reduce this target number by 1—to a minimum target modifier of 3—for every consecutive turn the firefighting infantry unit continues to battle a blaze in a single hex; if the platoon stops fighting a fire before it is extinguished, it must start over again. For each additional active platoon fighting the fire, the controlling player may make a separate roll for each successful attack, or apply a -1 modifier for each additional active platoon to a single roll.

• **Minesweeping Engineers:** Minesweepers are specially trained troops adept at disabling mines without detonating them. When a minesweeper platoon enters a mined hex, they may elect to disable the mines in place of a weapon attack (at the controlling player's discretion). When disabling mines, the platoon's controlling player must make a 2D6 roll; if multiple types of minefields occupy the same hex, a roll must be made for each type of minefield. On a result of 9+, the minefield is cleared. On a result of 3 or less, the field detonates. On any other result, the minesweepers have failed and the minefield remains active. See *Clearing Minefields* for more information.

• **Sensor Engineers:** These troops carry Remote Sensors (see p. 375) and dispenser gear that can set up to 2 Remote Sensors per squad. Only a single Remote Sensor need be deployed per hex in a given turn, at a cost of 1 MP (though the platoon may make ranged attacks as normal). Once established, an infantry-deployed Remote Sensor functions per the Remote Sensor rules referenced above.

**Trench/Fieldworks Engineers:** These engineers dig trenches and set up ad-hoc field works that can be used as handy cover for any infantry unit. A trench/fieldworks hex (called a fortified hex) may be established in any hex except for those containing water, pavement or buildings, and provides a +2 modifier to any attacks (except for flamers and area-effect weapons) made against any infantry unit that subsequently "digs into" the fortified hex (see *Digging In*, p. 108). (Fortified hexes made of clear terrain are also not treated as clear when determining damage against infantry.) Creating trenches and fieldworks takes 3 full turns to complete, during which time the engineering unit may take no other action. As with Bridge-Building Engineers, damage to a unit during a turn in which it is attempting to fortify a hex in this fashion extends the effort by 1 turn (regardless of the number of attacks made against the unit). If a Trench/Fieldworks unit is destroyed before completing its task, the underlying terrain remains unchanged and provides no modifiers.

**Marines:** Marines in the *Classic BattleTech* universe are troops trained to fight equally well in zero-G combat and on the ground. During combat operations in vacuum or zero-gravity (see pp. 54-55), or boarding actions (see p. 199), Marine units suffer no combat penalties associated with vacuum and zero-G operations; instead, they function in such environments as though they were conventional foot infantry under correspondingly normal conditions.

**Mountain Troops:** These troops are adept at ground combat in high altitudes and are immune to the effects of thin atmospheres (but not vacuum; see p. 54). Their climbing gear also enables them to traverse 3 levels per hex, as opposed to the typical 1 level per hex for other ground infantry.

**Paramedics:** These are conventional infantry units with paramedic equipment and the combat medics to use it. Any infantry unit with Paramedics that moves adjacent to (or into) a hex where there are wounded individuals may tend to up to 10 wounded individuals starting in the following turn. Paramedics may be combined with any conventional infantry unit type that can carry secondary weapons.

**Paratroops:** Paratroops are specialized foot infantry trained and equipped to deploy into combat in parachutes or parafoils. In any atmospheric combat scenario (except for vacuum), paratroop infantry units may deploy via combat drops from any suitable aerospace unit operating within the atmosphere (but below the Space-Atmosphere Interface on the High-Altitude Map). When the troops land, however, the controlling player must roll 2D6 for each squad in a paratroop unit. On a result of 3 or less, the squad suffers 1 casualty and scatters like a scattered battle armor unit. Dropping paratroop infantry may be attacked as other dropping units, with no additional infantry modifiers. Complete rules for Dropping Troops are covered in *Strategic Operations*.

**SCUBA (Standard):** SCUBA troops operate as normal foot infantry on land, but may enter and move through water at 1 MP per hex (or depth) as a submarine or UMU-equipped unit. SCUBA infantry can submerge as low as 2 depths in game play, and possess weapons modified to fire underwater. However, their primary and secondary weapons have only half their standard range when used underwater (round down), and they may not employ disposable weapons.

**SCUBA (Motorized):** Similar to standard SCUBA infantry, these troops possess portable underwater propulsion gear in the form of either backpack aquatic "thrusters" or mini-sub "sleds" that can be quickly stowed when on land. As with Standard SCUBA infantry, these troops move at 1 MP per hex on land, but have 2 MP in water, and may—like their standard SCUBA counterparts—submerge as low as Depth 2. As with standard SCUBA units, primary and secondary weapons have only half their standard range when used underwater (round down), and they may not employ disposable weapons.

## SPECIALIZED INFANTRY TYPES TABLE

Specialty Type	Max Squad (Troops)	Max Platoon (Troops/Squads)	Max Secondary Weapons	MP (Type)	Added Tons (per Trooper)	Tech Ratings	Prohibited Terrain
Combat Engineers	10	20 / 2	0	*	0.1	(C/A-B-A)	*
Marines	10	30 / 4	*	*	0	(C/A-A-A)	*
Mountain Troops	10	20 / 2	1	1 (Ground)**	0	(B/A-A-A)	Water (Any)
Paratroops	10	30 / 3	1	1 (Ground)**	0.05	(B/A-A-A)	Water (Any)
Paramedics	†	† / †	†	†	0.05	(B/C-C-C)	†
SCUBA (Standard)	10	30 / 4	0	1 (Sub)**	0.05	(B/B-C-B)	Water (Depth 3+)
SCUBA (Motorized)	6	12 / 2	1	2 (Sub)**	0.1	(B/B-C-B)	Water (Depth 3+)

\*As chosen Motive Type (Foot, Motorized, Jump and Mechanized: [Hover, Wheeled, Tracked or VTOL] are all available to these units).

\*\*See special game rules.

†As platoon type chosen; Note that each Paramedic per platoon replaces 1 secondary weapon trooper

INTRODUCTION

ADVANCED  
GROUND MOVEMENT

ADVANCED  
COMBAT

ADVANCED  
BUILDINGS

ADVANCED  
SUPPORT  
VEHICLES

GENERAL  
RULES

ADVANCED  
SUPPORT VEHICLE  
CONSTRUCTION

ADVANCED  
WEAPONS  
AND EQUIPMENT

INDEX

RECORD SHEETS

# STRUCTURE

In the push to get the most from every ton of BattleMech design, researchers continue to experiment with ways to lighten every component possible while not compromising the integrity of these avatars of war. Three

promising structural alternatives were reportedly under development in recent years along these lines: composite structure, endo-composite structure and reinforced structure.

## COMPOSITE STRUCTURE

**R&D Start Date:** 3056 (Federated Commonwealth)

**Prototype Design and Production:** 3061 (Federated Suns)

Composite structure uses advanced fiber-reinforced materials to provide

a BattleMech framework that weighs half as much as standard internal structure, but avoids the bulk issues found in equivalent-weight endo-steel structure. Unfortunately, composite structure is markedly easier to damage.

## COMPOSITE STRUCTURE

**Rules Level:** Experimental

**Available To:** BM

**Tech Base (Ratings):** Inner Sphere (E/X-X-E)

**Game Rules:** All damage to the internal structure of a 'Mech using Composite Structure is doubled. Excess damage that transfers to a location still protected by armor must apply in accordance with the rules of the specific armor type, based on the weapon's normal remaining damage.

## ENDO-COMPOSITE STRUCTURE

**R&D Start Date:** 3063 (Lyran Alliance), 3071 (Clan Wolf [in-Exile])

**Prototype Design and Production:** 3067 (Lyran Alliance), 3073 (Clan Wolf [in-Exile])

**Introduced:** N/A

Lyran engineers were seeking a solution to the problem of bulky endo-

steel structure design without resorting to composites when the Jihad began. Their approach consisted of a mix of endo-steel and standard structure parts, dubbed endo-composite structure. It promised a partial success that unfortunately wound up in Blakist hands for several years—but not before Lyran resistance managed to leak technical details to the Exiled Wolves.

## ENDO-COMPOSITE STRUCTURE

**Rules Level:** Experimental

**Available To:** BM

**Tech Base (Ratings):** Both (E/X-X-F)

**Game Rules:** Functions in game play by the same rules as Endo-Steel; critical hits to Endo-Composite structure slots are treated as Roll Again results.

## REINFORCED STRUCTURE

**R&D Start Date:** 3055 (ComStar), 3060 (Clan Ghost Bear)

**Prototype Design and Production:** 3057 (ComStar/Word of Blake), 3065 (Clan Ghost Bear)

Prior to the fall of Terra to the Blakists, ComStar engineers were working on

an ultra-heavy chassis design intended to better resist the strain of internal damage, but Word of Blake espionage eventually led to the experimental technology leaking beyond the Order's drawing boards. The Clans have since launched their own research into the promise of super-resilient structure design.

**Structure:** Composite, Endo-Composite and Reinforced internal structure types are available to BattleMechs only.

The weight for Composite Structure is half as much as standard internal structure (rounded up to the nearest half-ton), but occupies no internal slots on the unit's design.

Endo-Composite Structure weighs three-quarters as much as standard structure (75 percent, rounded up to the nearest half ton), and occupies half as many slots (rounded up) as normal Endo-Steel (7 slots for Inner Sphere Endo-Composite; 4 slots for Clan Endo-Composite), which must be allocated per the standard rules for internal structure slots (see p. 47, *TM*).

Reinforced internal structure weighs twice as much as standard structure, but requires no slot space.

**Sub-Capital Weapons:** When mounted on appropriate Large Craft (DropShips, JumpShips, Space Stations and WarShips), Sub-Capital Weapons can be grouped in either their own bay or in the same bay as capital weapons of the same type (Sub-Capital Lasers may be combined with capital lasers, Sub-Capital Cannons may combine with capital autocannons and so on). When grouped with standard capital weapons, however, the Sub-Capital Weapons' to-hit modifiers are replaced by those of the capital weapon. Sub-Capital Weapons are mounted on any permissible aerospace unit using the same rules for standard capital weapons, including rules pertaining to gunnery crew needs, targeting system limits, minimum ammunition needs and so forth. (DropShips mounting Sub-Capital Weapons effectively ignore the prohibition concerning only-missile capital weapons.)

Beyond Large Craft, only Mobile Structures and Large-sized Support Vehicles of Tracked, Rail or Naval motive types may mount a Sub-Capital Weapon. For Mobile Structures, mounting a Sub-Capital Weapon follows the same rules as for mounting capital weapons (see p. 267). Support Vehicles intending to mount a Sub-Capital Weapon must incorporate a fusion or fission engine of at least Tech Level D, as well as an Advanced Fire Control System. Support Vehicle-mounted Sub-Capital Weapons may not be placed in a turret or pintle mount, and require 1 gunner for every 50 tons of weapon weight to operate. Sub-Capital Lasers mounted on Support Vehicles also require a number of heat sinks equal to the heat generated by such weapons, while Sub-Capital Cannons and missiles require no heat sinks.

## REINFORCED STRUCTURE

**Rules Level:** Experimental

**Available To:** BM

**Tech Base (Ratings):** Both (E/X-X-E)

**Game Rules:** Reinforced Structure suffers only 1 point of damage for every 2 points of damage sustained (rounded up), like Hardened Armor. Furthermore, when rolling to determine critical hits on a unit with Reinforced Structure, a -1 modifier applies to the roll result. Reinforced Structure does not allow more armor to be mounted on a 'Mech.

## SUB-CAPITAL WEAPONS

Derived from Terra's rebuilt defenses (and likely scrapped naval weapon concepts from the Age of War), the Word of Blake recently unveiled a new, smaller class of naval weapons. Dubbed sub-capital weapons, these sys-

tems have apparently been shipped to various key worlds throughout the Protectorate, where a few courageous resistance groups have managed to smuggle out specs and partial samples to the various allied forces.

## SUB-CAPITAL WEAPONS

**Rules Level (General):** Advanced

**Available To (General):** SV, DS, JS, SS, WS, MS

**Game Rules (General):** Sub-Capital Weapons use capital-scale attack values and range brackets, and follow all the same basic rules as capital weapons of their equivalent type (Capital ACs for Sub-Capital Cannons; Naval Lasers for Sub-Capital Lasers; Capital Missiles for Sub-Capital Missiles), with the following differences:

- Sub-Capital Weapons firing through the Space/Atmosphere Interface on the High-Altitude Map suffer an additional +2 to-hit modifier in addition to all other modifiers and rules applicable to capital weapons fire through atmosphere (see p. 236, *TW*).
- Ground-based units firing sub-capital weapons (excluding grounded DropShips and Mobile Structures) must stop moving for 1 full Space-scale turn (6 standard ground combat turns) before firing, and also may not move in the firing turn.
- Direct-fire Sub-Capital Weapons (SCCs and SCLs) may attack targets under 500 tons at a +3 to-hit modifier (rather than the normal +5). Sub-Capital Missiles do not apply this modifier.
- Direct-fire Sub-Capital Weapons may not be fired from a Ground hex on the High-Altitude Map against any other unit on the Ground hex row on the High-Altitude Map.
- Sub-Capital Missiles may execute surface-to-surface attacks as artillery (such rules are covered in *Strategic Operations*), but with a range (in Space hexes) equal to their capital hex range, divided by 6 (round up), and a ground combat turn delay of 6 ground-scale turns per Space hex traveled. Such attacks also suffer a +2 to-hit modifier.
- Sub-Capital Weapons used to deliver a strike against ground-based targets deliver their full damage only against the target hex—and all units therein—plus half their rated damage to the adjacent hexes (and all units therein). Remember that 1 point of capital-scale damage translates to 10 points of standard-scale damage when attacking ground units in this fashion.

## SUB-CAPITAL CANNONS

**Introduced:** 3073 (Word of Blake)

These lighter forms of the naval autocannon lack the size and the "burst rate" of their larger kin, but can track smaller targets more effectively than

their larger cousins. Since rumors of these weapons leaked out, FedSuns weapon designers and their Combine counterparts have both launched crash programs to develop their own sub-capital cannons, hoping to negate the Blakist advantage before their new weapons went into full production.

## SUB-CAPITAL CANNONS

**Tech Base (Ratings):** Inner Sphere (E/X-X-F)

**Game Rules:** If not grouped with standard Naval Autocannons in a weapon bay, a Sub-Capital Cannon (SCC) receives a +3 modifier to attack units weighing less than 500 tons (in place of the standard +5 modifier for capital weapons). Otherwise, Sub-Capital Cannons function as described in the general rules above.

## SUB-CAPITAL LASERS

**Introduced:** 3073 (Word of Blake)

Though the Word once more beat out the allies for production of these, the preferred sub-capital weapon, all of the Great House states save the

Federated Suns and the Capellan Confederation are close to field-testing their own knock-offs on retrofitted "pocket WarShips" of their own.

## SUB-CAPITAL LASERS

**Tech Base (Ratings):** Inner Sphere (E/X-X-F)

**Game Rules:** If not grouped with standard Naval Lasers in a weapon bay, a Sub-Capital Laser (SCL) receives a +3 modifier to attack units weighing less than 500 tons (in place of the standard +5 modifier for capital weapons). Otherwise, Sub-Capital Lasers function as described in the general rules above.

INTRODUCTION

ADVANCED  
GROUND MOVEMENT

ADVANCED  
COMBAT

ADVANCED  
BUILDINGS

ADVANCED  
SUPPORT  
VEHICLES

GENERAL  
RULES

ADVANCED  
SUPPORT VEHICLE  
CONSTRUCTION

ADVANCED  
WEAPONS  
AND EQUIPMENT

INDEX

RECORD SHEETS

## SUB-CAPITAL MISSILE LAUNCHERS

**Introduced:** 3072 (Word of Blake), 3073 (Clan Wolf [in-Exile])

Sub-capital missiles are the only sub-capital weapon types known to have been under development prior to the Jihad (though suspicions remain that the Word was actively pursuing other sub-capital weapon types at the same time). These weapons lack the range and punch of larger capital missiles, and

are also incompatible with the AR-10 launcher, but are adept at anti-fighter work and useful across a broad range of unit types. Their straightforward design and co-development with Free Worlds engineers who later defected to Alys Marik's resistance eventually led to other realms adopting this technology, including the Lyrans, the Combine and even the Clans.

### SUB-CAPITAL MISSILE LAUNCHERS

**Tech Base (Ratings):** Both (E/X-X-F)

**Game Rules:** Sub-Capital Missiles function in accordance with the general Sub-Capital Weapons rules above. Furthermore, if not grouped together with standard capital missiles (or other Sub-Capital Missiles), Piranha-class Sub-Capital Missile bays receive a -1 to-hit modifier to reflect the more nimble maneuvering systems of these smaller warheads. Space-based Point defenses, including Anti-Missile Systems, affect Sub-Capital Missiles in the same manner as capital missiles, but in atmosphere, these defensive armaments have no effect against Sub-Capital Missiles.

Like standard capital missiles, most Sub-Capital Missiles may inflict an additional critical hit against aerospace targets when they deliver a successful hit. The Sub-Capital Missile Critical Table below provides the chances of an additional critical hit on a separate 2D6 roll (made after a successful hit).

Sub-Capital Missiles cannot be launched from an AR-10 launcher, nor do tele-operated versions exist for any of these missiles, but they can be used to deliver surface-to-orbit attacks and vice versa (those rules are covered in *Strategic Operations*).

### SUB-CAPITAL MISSILE CRITICAL TABLE

Missile	Critical Chance
Piranha	N/A
Stingray	12+
Swordfish	11+
Manta Ray	10+

## SUB-COMPACT K-F DRIVE SYSTEM

**Introduced:** 2320 (Terran Hegemony)

Inner Sphere naval engineers and historians have long known that the Star League could build Kearny-Fuchida drives as small as 2,500 tons. However, even the recovery of the Helm Memory Core failed to unlock the mystery of these sub-compact cores, leaving vessels like the well-known *Bug-Eye* stuck in ComStar's nostalgic Star League archives (and in Clan naval reserves).

Only the recent and historic collaboration between Inner Sphere naval engineers and their counterparts in Clans Wolf (in-Exile) and Nova Cat finally cracked the counterintuitive secret to compact K-F drive design. Unfortunately, the bare bones, nearly titanium-free design of sub-compact K-F drives proved prohibitively expensive, even when using Clan manufacturing techniques. As a result, sub-compact K-F drives have become rare to the point of virtual extinction.

### SUB-COMPACT K-F DRIVE SYSTEM

**Rules Level:** Experimental

**Available To:** JS, WS

**Tech Base (Ratings):** Both (F/F-X-F)

**Game Rules:** The Sub-Compact K-F Drive follows normal K-F drive rules. However, as the use of a sub-compact drive produces an extra-small hyperspace field, a vessel using a Sub-Compact K-F Drive cannot transport DropShips through hyperspace.

**Sub-Compact K-F Drive System:** A WarShip mounting a Sub-Compact K-F Drive must devote 50 percent of the vessel's total mass to the drive. A jump-capable vessel with a sub-compact K-F Drive may be built as small as 5,000 tons, but no larger than 25,000 tons. A vessel with a sub-compact core may not mount DropShip docking collars. Full rules on constructing the units that use this item will appear in *Strategic Operations*.

**Supercharger:** The Supercharger may be mounted on any BattleMech or IndustrialMech. Combat Vehicles and Support Vehicles not powered by Solar Power or External power engines may also mount a Supercharger unless they are also VTOLs, Fixed-Wing, Airship or Satellite vehicle types. All other unit types may not mount a Supercharger. The Supercharger itself occupies 1 critical space, which must be placed in a location that contains engine slots (this can be a left or right torso, provided engine slots exist in those locations) and has a weight equal to one-tenth of the unit's engine weight (rounded up to the nearest half-ton for units 5 tons and over, or to the nearest kilogram for units under 5 tons).

**Taser:** Only battle armor may mount a Battle Armor Taser, and only one Battle Armor Taser may be mounted per battlesuit, unless the Taser is mounted semi-externally, in a Detachable Weapon Pack.

BattleMech Tasers may be mounted on BattleMechs, IndustrialMechs, Combat Vehicles and all Support Vehicle types except for Satellites, Airships and Fixed-Wing units in accordance with the standard construction rules. However, only units powered by a fusion engine can use BattleMech Tasers.

# SUPERCHARGER

**Introduced:** Early spaceflight

Essentially an override for the normal safety governors that limit modern engine performance, superchargers can coax as much as 125 percent output from fusion reactors and internal combustion engines alike. For fusion and fission plants, this generally entails disabling safety inhibitors and the like,

while fuel-based systems inject a burst of specially designed chemicals into the fuel mix to achieve similar results.

As might be expected, use of a supercharger carries significant risks to the engine's integrity, up to and including supercharger burnout or even catastrophic engine failure.

INTRODUCTION

ADVANCED  
GROUND MOVEMENT

ADVANCED  
COMBAT

ADVANCED  
BUILDINGS

ADVANCED  
SUPPORT  
VEHICLES

GENERAL  
RULES

ADVANCED  
SUPPORT VEHICLE  
CONSTRUCTION

ADVANCED  
WEAPONS  
AND EQUIPMENT

INDEX

RECORD SHEETS

## SUPERCHARGER

**Rules Level:** Experimental

**Available To:** BM, IM, CV, SV

**Tech Base (Ratings):** Inner Sphere (C/F-F-F)

**Game Rules:** The Supercharger enables a unit to move at twice its standard Cruising or Walking MP as an enhanced run, and follows the same rules to operate as MASC (see pp. 137, *TW*), with the following exceptions:

- Superchargers mounted on IndustrialMech or Support Vehicle engines apply a -1 modifier to the Supercharger's activation roll result (the 2D6 roll made prior to movement).
- On a failed Supercharger activation roll, rather than assigning critical damage to legs, the controlling player rolls on the unit's appropriate Determining Critical Hits Table and applies all critical hits to the engine. For 'Mech units, this applies to the upper-most undamaged critical slot in the center torso. For non-'Mechs, these critical hits apply first to the motive systems and then (after the unit is immobilized in such a fashion) transfer inward to the engine itself, destroying the engine immediately on the first hit.
- Regardless of whether or not engine or motive damage occurs, a failed Supercharger activation roll destroys the Supercharger system and the unit may not use it for the remainder of the scenario; the equipment slot is considered destroyed.
- A 'Mech may combine a Supercharger with MASC. If both are used in the same round, the controlling player must make separate activation rolls for each. If successful, the unit receives a Running MP equal to 2.5 times its Walking MP (rounded up).

# TASER

**R&D Start Date:** ca. 3060 (Word of Blake [Battle Armor Taser]), 3065 (Federated Suns [BattleMech Taser])

**Prototype Design and Production:** circa 3066 (Word of Blake [Battle Armor Taser]), 3067 (Federated Suns [BattleMech Taser])

**Introduced:** 3067 (Word of Blake [Battle Armor Taser]), N/A [BattleMech Taser]

Though reportedly developed by the NAIS as a 'Mech-scale weapon first, the radical taser weapon system first appeared at a smaller scale, employed

by Word of Blake battle armor. Designed to incapacitate rather than destroy, the weapon uses a wire-based, armor-piercing harpoon to penetrate the outer skin of its target and deliver a powerful electromagnetic charge directly from the shooting unit. This jolt, powerful enough to disable the target for a brief period, relies on high-energy capacitors or a direct feed from the firing unit's engine, and carries with it a major risk of energy feedback that can prove just as harmful to the attacker as to the target.

## TASER

**Game Rules (General):** In game play, apply a +1 to-hit modifier for attacks by a unit firing a Taser. The Taser may only target ground-based units (such as 'Mechs, battle armor and vehicles), grounded VTOLs and grounded aerospace units. The Taser has no effect against buildings or units weighing more than 100 tons. A Taser may not be fired underwater, nor does it gain any benefits from a targeting computer.

If the target is conventional infantry, a successful Taser hit automatically kills 1 trooper (regardless of the Taser type used). Against any other target, the weapon inflicts 1 point of damage, after which the Attacker then rolls 2D6 and consults the Taser Effects Table below, then cross-references the target unit type against the columns appropriate for the Taser type used.

If the roll result is equal to or higher than the value outside the parentheses under the appropriate Shutdown column, the Taser causes the target unit to shut down for a number of turns equal to the value in parentheses. Battle armor units that experience a shutdown effect lose one random trooper, which is treated as destroyed for the remainder of the scenario. All other units experiencing a shutdown become immobile targets for the duration of the effect.

If the 2D6 roll is less than the Shutdown column value, the Taser's surge simply disrupts the unit's electronics, creating interference that impairs the unit's function. This interference applies a modifier to the target unit's Piloting and Gunnery target numbers as listed under the Interference column for the appropriate Taser, and lasts for a number of turns equal to the value in parentheses.

Multiple Taser hits do not increase the modifiers for interference effects or the chances of a shutdown effect, but will require shutdown checks for each successful hit (however, a unit shut down by one Taser hit may not be "restarted" by a later Taser hit that fails to roll a shutdown). Any interference effects last from the turn of the most recent successful Taser hit. Shutdown and interference effects end during the End Phase of the final turn of their duration, and so a BattleMech experiencing interference from a Battle Armor Taser hit in Turn 1 will recover from its effects in the End Phase of Turn 4.

## BATTLE ARMOR TASER

Appearing suddenly in special Word of Blake battle armor squads, the battle armor-scaled taser is the riskier form of the taser weapon. While its single harpoon—delivered by Gauss-style magnetic accelerators—is hardly dam-

aging, the immense pulse from its integral capacitor invariably disrupts the battlesuit's own electronic systems and can even shut down the suit entirely. For this reason, the battle armor taser sees limited use, even by the Word.

## BATTLE ARMOR TASER



**Rules Level:** Advanced

**Available To:** BA

**Tech Base (Ratings):** Inner Sphere (E/X-X-E)

**Game Rules (General):** The Battle Armor Taser uses all of the general Taser firing rules noted above, with the following additions:

- Battle Armor Tasers are one-shot weapons.
- Even if all troopers in a squad are equipped with a Battle Armor Taser, only 1 trooper fires at a time, so if a full Word of Blake battle armor squad of 6 is equipped with Battle Armor Tasers, they may make up to 6 Taser attacks per scenario.
- Units experiencing shutdown effects from a Battle Armor Taser strike may restart before the effects' full duration by making a 2D6 roll during the End Phase of each turn they are so shut down. BattleMechs restart on a result of 7+; all other units restart on 8+.
- Upon making a successful hit with a Battle Armor Taser, regardless of the effects, the Attacker must make a Feedback check by rolling 2D6 again. On a result of 7+, the firing unit receives a +1 modifier to all attack rolls for the next 3 turns (applied to the entire squad). On a result of 6 or less, the Taser's capacitor explodes on the surge, disabling the battlesuit for the remainder of the scenario. (The trooper is treated as destroyed for scenario purposes, but the suit and its operator may be salvaged later.)
- Unless it simply missed its target when fired, a Battle Armor Taser cannot be reloaded after a scenario; instead, the weapon must be replaced.

## BATTLEMECH TASER

First seen in the Solaris arenas during a duel between rival FedSuns stables, the BattleMech taser is a larger, reloadable and far less risky version of the battle armor taser. Combining the micro-Gauss firing system of the battlesuit version with a rocket-propelled harpoon, and designed to tap into

the much deeper power reserves of a fusion reactor (rather than the battle armor version's capacitor), the BattleMech taser is somewhat more effective in combat, at decidedly less risk.

## BATTLEMECH TASER



**Rules Level:** Experimental

**Available To:** BM, IM, CV, SV, MS

**Tech Base (Ratings):** Inner Sphere (E/X-X-F)

**Game Rules:** The BattleMech Taser uses all the general Taser rules described above, with the following additions:

- BattleMech Tasers are treated like Gauss weapons in the event of a critical hit to the weapon, and explode for 6 points of damage.
- BattleMech Taser ammo can explode in the event of a critical hit, inflicting 6 points of damage per unused shot left in the bin.

### TASER EFFECTS TABLE

Target Unit*	Battle Armor Taser		BattleMech Taser	
	Shutdown	Interference	Shutdown	Interference
BattleMech	12+ (3)	+1 (3)	11+ (3)	+2 (3)**
IndustrialMech	11+ (3)	+1 (3)	8+ (4)	+2 (4)**
ProtoMech	11+ (3)	+1 (3)	8+ (4)	+2 (4)
Battle Armor†	9+ (P)	NA	Auto (P)	NA
Vehicles	11+ (3)	+1 (3)	8+ (4)	+2 (4)
Aerospace Fighter/Small Craft‡	11+ (3)	+1 (3)	11+ (3)	+2 (3)**
Conventional Fighters‡	11+ (3)	+1 (3)	8+ (4)	+2 (4)

\*Tasers have no effect against units weighing more than 100 tons.

\*\*The unit also generates 5 points of heat per turn while affected.

†Effects apply to one trooper only, for the remainder of the scenario.

‡Grounded units only; Tasers cannot target airborne units.

**Thunderbolt Missile Launcher:** May be mounted on any available unit type in accordance with the unit's standard construction rules.

**BattleMech Turret:** All of the turrets described here have a weight equal to 10 percent of the tonnage of all weapons assigned to the turret (not including power amplifiers, heat sinks and ammunition). Sponson Turrets, which are always mounted in pairs, treat this weight as tonnage that applies across both turrets, but as they must mount the same tonnage of weapons—though not necessarily the same types of weapons—this translates to 5 percent of weapon tonnage per turret. Round all turret weights up to the nearest half-ton. For 'Mech Turrets, a critical slot must also be assigned to the unit's record sheets to represent the turret mechanism (and the weapons assigned to that turret must be noted on the record sheet as well).

BattleMech shoulder turrets (available only to biped BattleMechs) must assign the turret mechanism slot to either the left or right torso locations, which may support a maximum of 1 shoulder turret each. Only the items placed in that side torso may be assigned to the shoulder turret.

BattleMech head turrets (available to quad or biped 'Mechs) require a turret critical slot in the center torso. A 'Mech must be using a torso-mounted cockpit (see p. 301) to mount a head turret.

BattleMech quad turrets (available only to four-legged 'Mechs) follow the same construction rules as a BattleMech shoulder turret, but a quad may only carry 1 turret.

# THUNDERBOLT MISSILE LAUNCHER

**Introduced:** 3072 (Federated Suns, Lyran Alliance)

An experimental weapon system first prototyped by NAIS engineers in the mid-3050s for the Solaris arenas, the Thunderbolt missile launcher was derived from standard LRM technology. By using a larger missile, rather than

clusters of small warheads, the Thunderbolt can deliver a single concentrated hit to its target, but does so at the expense of range, weapon weight and heat. Nevertheless, the proven nature of this technology led to its eventual mass production by the former FedCom states in the early 3070s.

## THUNDERBOLT MISSILE LAUNCHER

**Rules Level:** Advanced

**Available To:** BM, IM, CV, SV, AF, CF, SC, JS, DS, SS, WS, MS

**Tech Base (Ratings):** Inner Sphere (E/X-X-F)

**Game Rules:** Thunderbolt Missile Launchers follow all the standard rules for LRMs in combat, including the ability to launch indirect LRM fire (see p. 111-112, *TW*). However, unlike LRMs, Thunderbolt missiles do not roll on the Cluster Hits Table. They deliver their damage to a single location, rather than in clusters, and any Thunderbolt missile strike that occurs within the weapon's minimum range delivers only half the missile's rated damage, rounded down (as the missile's warhead does not arm itself until after launch).

Anti-missile systems may engage an incoming Thunderbolt missile, using the standard rules for AMS versus a single missile weapon (see p. 129, *TW*).

Thunderbolt Missile Launchers only use standard Thunderbolt ammunition, and do not benefit from missile enhancement systems such as Artemis and Narc.

# TURRETS

**Introduced:** Pre-spaceflight

Turrets, by and large, are nothing new to the modern battlefield, yet war machines in the thirty-first century have settled into certain design standards,

mainly for the sake of simplified engineering. Far more unusual options, however, have cropped up from time to time, including 'Mech-mounted turrets, dual vehicle turrets, sponson turrets and VTOL chin turrets.

## BATTLEMECH TURRET

**Rules Level:** Experimental

**Available To:** BM, IM

**Tech Base (Ratings):** Both (C/F-X-F)

**Game Rules:** BattleMech Turrets come in three primary forms: shoulder turrets, quad 'Mech turrets and head turrets. Bipedal (non-quad) 'Mechs may only mount shoulder and head turrets, while quads may only use quad 'Mech turrets and head turrets. In all three cases, the weapons assigned to these turrets—which must be clearly noted on the unit's record sheet—may be rotated to any desired facing in accordance with the rules for vehicle turrets (see pp. 105-106, *TW*). In the case of shoulder turrets, however, the turret may not fire through either of the 'Mech's opposite-side hexsides (as doing so would essentially be firing through the unit's own head).

Unlike vehicle turrets, BattleMech Turrets have no distinct hit locations and are treated as part of the body location in which they are mounted. Furthermore, all BattleMech Turrets have a critical slot representing the turret mechanism itself. If this slot sustains a critical hit, the turret is locked in the facing it had during the turn in which the critical hit occurred, and remains in that facing until repaired.

## VEHICULAR DUAL TURRET

**Rules Level:** Experimental

**Available To:** CV, SV

**Tech Base (Ratings):** Both (B/F-X-F)

**Game Rules:** Available to ground-based and naval-based Combat and Support Vehicles (but not airborne units such as VTOLs, Airships, Fixed-Wing units and Satellites), the Vehicular Dual Turret refers to the placement of a second turret in a single-hex Combat or Support Vehicle design. (Multi-hex units can mount one turret per hex, and so do not receive this option.)

Vehicles with a dual turret configuration must note one turret as the forward turret and one as the rear turret. These turrets follow the same rules as standard vehicle turrets, but the forward turret may not fire through the rear hexside, while the rear turret—which is elevated above the forward—has a full 360-degree arc. Both turrets are treated as a separate hit location, each with its own armor and structure; when a vehicle mounting dual turrets suffers a hit to the turret location, the attacker must roll 1D6, applying a -2 modifier for hits through the front arc or a +2 modifier for hits through the rear arc. If the modified result is 3 or less, the front turret suffers the damage; on a modified result of 4 or higher, the rear turret is hit instead. Any critical hits to a vehicle's turret apply to the turret which received the damage.

INTRODUCTION

ADVANCED  
GROUND MOVEMENT

ADVANCED  
COMBAT

ADVANCED  
BUILDINGS

ADVANCED  
SUPPORT  
VEHICLES

GENERAL  
RULES

ADVANCED  
SUPPORT VEHICLE  
CONSTRUCTION

ADVANCED  
WEAPONS  
AND EQUIPMENT

INDEX

RECORD SHEETS

## VEHICULAR SPONSON TURRET



**Rules Level:** Experimental

**Available To:** CV, SV

**Tech Base (Ratings):** Both (B/F-X-F)

**Game Rules:** Available to ground-based, naval-based and VTOL Combat and Support Vehicles (but not other units such as Airships, Fixed-Wing units and Satellites), Sponson Turrets are larger-scale versions of the pintle mount occasionally seen on smaller Support-grade Vehicles. Sponsons, unlike pintles, may carry heavy weapons and are always mounted in pairs as an alternative to standard side-mounted weapons. Like pintles, however, they receive no independent armor and structure values, and offer the same 180-degree arc of fire, encompassing the whole range of hexes from the hex row directly behind a vehicle to the hex row directly ahead (meaning both Sponsons will overlap directly ahead of and directly behind a vehicle). Unlike other turrets, Sponsons cannot be jammed; the weapons are simply treated as standard side-mounted weapons for the purposes of resolving critical hits.

## VTOL CHIN TURRET



**Rules Level:** Experimental

**Available To:** CV, SV

**Tech Base (Ratings):** Both (B/F-F-F)

**Game Rules:** The VTOL "Chin" Turret is so named because it generally resides beneath the cockpit section of the craft. The Chin Turret follows all the standard rules for a vehicle turret except that it cannot be used to target units standing (or flying) at a higher elevation than the VTOL itself.

## VEHICULAR/BATTLE ARMOR DROPCHUTE

**Introduced:** 2351 (Terran Hegemony [VDC]), 2875 (Clan Hell's Horses [BADC])

Descended from the landing chutes of early spaceflight planetary probes, the combat vehicular dropchute (VDC)—and its battle armor equivalent (BADC)—are not so much a mounted equipment item as an external add-on that enables vehicles, 'Mechs, battle armor and even inert cargo to be dropped from low atmospheric orbit. Intended as an economical

alternative to the standard BattleMech drop cocoon, VDCs and BADCs are limited in combat, largely because chute-deployed troops are easier to target by hostile aerospace units, and rely on atmospheric drag rather than controlled thrust to slow their descent. This latter issue is considerably more dangerous when deploying by chute into turbulent atmospheric conditions, such as the height of a storm.

## VEHICULAR JUMP JETS

**Introduced:** 2650 (Terran Hegemony)

**Extinct:** 2840 (Inner Sphere)

During the heyday of the first Star League, Mitchell Vehicles of Graham IV introduced the first jump-capable hovertank—the KGA-2B Kanga—to the SLDF. Built to compete with the mobility of BattleMechs, the Kanga's unique vehicular jump jet system was a stunning success, but one that few could replicate thanks to the elaborate computer and guidance systems needed

to stabilize the hovertank in flight. As a result, few jump-capable vehicles beyond the Kanga were ever created, especially after the destruction of the vehicle line on Graham in 2780. Even the Clans (Hell's Horses notwithstanding), who retained the technology through the Succession Wars, viewed it as prohibitively expensive and complex, all but sidelining the technology in the centuries since the Star League's collapse.

**Vehicular Dropchute (VDC)/Battle Armor Dropchute (BADC):** Only battle armor, 'Mechs, ProtoMechs and Vehicles with a Wheeled, Tracked, Hover or WIGE motive system may use a VDC. Naval vehicles and vehicles with VTOL, Fixed-Wing, Airship, Satellite or Rail motive types may not employ VDCs. No unit weighing more than 100 tons may use a VDC. Only battle armor and exoskeleton units may use a BADC.

Unless the VDC is reusable, this item occupies no tonnage or critical space within the unit. Instead, it is treated as unprotected cargo for movement and combat purposes (see pp. 260-261, *TW*), except that this cargo is considered strapped to the unit's back, may not be hit except for hits to the unit's rear arc, and leaves any arms or turrets free to act normally. Non-reusable BADCs have no impact in game play.

Reusable VDCs—available to all appropriate units—can only be mounted in a vehicle's rear location, any of a 'Mech's three torso locations or in a ProtoMech's body (taking up a weapon slot). Reusable VDCs add half a ton to their base weight for the retraction and stowing systems, with the total tonnage of the equipment rounded up to the nearest half ton for construction purposes. Reusable BADCs must be located in a battle armor suit's body location.

**Vehicular Jump Jets:** Vehicular jump jets weigh the same as standard jump jets do on a BattleMech of equivalent weight (see p. 51, *TM*), but occupy only one equipment slot (in the vehicle's body). Because the steering thruster nozzles for such jets must be mounted on the sides of the vehicle, a unit equipped with vehicular jump jets may not mount sponson turrets (above).

Only vehicles with hover, wheeled, tracked, or Wing-in-Ground Effect (WIGE) motive types may mount vehicular jump jets. Each jump jet provides 1 Jump MP. As with standard BattleMech jump jets, a vehicle may not mount more vehicular jump jets than it has Cruise MP. Vehicles do not require heat sinks to mount vehicular jump jets.

**Void-Signature System:** The Void-Signature System must be combined with one or more ECM suites. The system itself does not weigh a significant amount, but occupies 1 critical slot in each of the BattleMech's locations except the head (that is, one slot each in the right and left arm, or front legs on a four-legged 'Mech, and the right and left leg, and one in the each of the left, right and center torsos, for a total of 7 critical slots).

A 'Mech with this system may not mount an advanced targeting computer or C<sup>3</sup> system, Stealth armor, the Chameleon light polarization shield or a Null-Signature System.

The Void-Signature System cannot be installed on an OmniMech via OmniPods.

## VEHICULAR DROPCHUTE (VDC)/BATTLE ARMOR DROPCHUTE (BADC)

**Rules Level:** Advanced

**Available To:** BA, PM, BM, IM, CV, SV

**Tech Base (Ratings):** Both (Variable)

**Game Rules:** Applicable units using VDCs (or BADCs) during a combat drop (instead of Jump Packs or integral jump jets) follow all the standard rules for a combat drop (those rules are covered in *Strategic Operations*), with the following exceptions:

- VDC/BADC drops may only be attempted over planets with an atmospheric pressure of Thin or higher. VDC/BADC drops cannot be attempted in Very Thin or Vacuum atmosphere.
- VDC/BADC drops by manned units apply an additional +1 modifier to the Piloting Skill roll upon landing; this modifier rises to +3 if the unit is unmanned (or out of control due to engine shutdown, gyro destruction or pilot incapacitation). Any modifiers for weather conditions in the landing zone are doubled as well.
- While dropping, hostile aerospace units may apply a -2 to-hit modifier (-1 if the unit is using a Stealth VDC/BADC) to attacks against unit's chute (not the unit itself). However, each hit to a VDC or BADC delivers only 1 point of damage (Cluster weapons treat each point cluster as a separate hit). If the target is BADC-deployed battle armor, the attacking unit must roll to see which trooper's chute is hit, as damage to their chutes must be tracked separately.
- If the VDC sustains 15 points of damage or more (BADCs can sustain only 5 points of damage per trooper), or is detached by the controlling unit (requiring a successful Piloting Skill roll during the Movement Phase), the dropping unit plunges to the ground and is destroyed unless it has jump jets to control its fall (in which case, standard Dropping Troops rules apply, which are covered in *Strategic Operations*).

In addition, units deployed by Camouflage or Stealth VDCs or BADCs prior to the start of play may use the chutes to begin play as hidden units. A unit with a functioning active probe will only detect a unit hidden by a Stealth chute if the probe unit enters a hex adjacent to the hidden unit.

Reusable VDCs and BADCs (an option in which the chutes may be retracted and stowed for later use) take 5 minutes (30 standard ground-scale turns) to stow, during which time the chute-equipped unit may not move (but may make attacks normally). Attacks against a Reusable chute in the process of being stowed receive the -4 immobile target modifier, and inflict damage against the chute in the same manner as noted above for aerospace attacks on a deployed VDC or BADC.

## VEHICULAR JUMP JETS

**Rules Level:** Experimental

**Available To:** CV, SV

**Tech Base (Ratings):** Both (E/E-X-F)

**Game Rules:** A vehicle equipped with Vehicular Jump Jets (and a functioning engine) can use Jumping MP in the same manner as suitably equipped BattleMech, with these exceptions:

- Every time the vehicle jumps, the controlling player must roll on the Motive System Damage Table (see p. 193, *TW*) to see what—if any—motive damage occurs upon landing. This roll disregards the standard modifiers for attack direction, however, and replaces the vehicle type modifiers with the following: +2 for Tracked vehicles, +1 for Wheeled vehicles, -1 for hovercraft, and -2 for WiGE vehicles. An additional +1 is applied if the vehicle jumps into Rough, Woods, or Jungle terrain of any kind.
- Jump-capable vehicles may not jump into any terrain restricted by their motive type, nor may such vehicles execute a Death from Above attack.
- Jump-capable vehicles designated as tractors or trailers may not use Jump MPs while attached to other vehicles.

# VOID-SIGNATURE SYSTEM

**R&D Start Date:** 3060 (Word of Blake)

**Prototype Design and Production:** 3070 (Word of Blake)

An evolution of the Chameleon light polarization shield and the null-

signature system, the Word of Blake's experimental void-signature system ties into a unit's sensors and uses a large-scale variation on mimetic armor technology to render a BattleMech virtually invisible.

## VOID-SIGNATURE SYSTEM

**Rules Level:** Experimental

**Available To:** BM

**Tech Base (Ratings):** Inner Sphere (E/X-X-E)

**Game Rules:** A player may turn the Void-Signature System on or off during the End Phase of any turn. A 'Mech may also start the game with the system already engaged. While a Void-Signature System is active, the effect is similar to Mimetic battlesuit armor (see p. 228, *TW*), with the following changes:

- The to-hit penalties for attacks against a BattleMech using a Void-Signature System are based on the number of hexes the 'Mech moved during the Movement Phase. For 0 hexes moved, the to-hit modifier is +3; for 1 to 2 hexes, +2; and for 3 to 5 hexes, +1. If the 'Mech moved 6 hexes or more, no modifier applies. Reduce these modifiers by 1 (to a minimum of 0) if the attacking unit is conventional infantry.
- Only a Bloodhound probe (see p. 278) can penetrate the Void-Signature System's masking effect. The Watchdog system, Beagle Active Probe and their Clan equivalents may not detect a hidden unit using a Void-Signature System.
- A critical hit to any of the Void-Signature System's critical slots will destroy the entire system, as will the loss of all active probes mounted on the unit.
- While active, the Void-Signature System generates 10 points of heat per turn, and imposes a +1 to-hit modifier on all weapon attacks made by the controlling unit.

INTRODUCTION

ADVANCED  
GROUND MOVEMENT

ADVANCED  
COMBAT

ADVANCED  
BUILDINGS

ADVANCED  
SUPPORT  
VEHICLES

GENERAL  
RULES

ADVANCED  
SUPPORT VEHICLE  
CONSTRUCTION

ADVANCED  
WEAPONS  
AND EQUIPMENT

INDEX

RECORD SHEETS

## VTOL JET BOOSTER

**Introduced:** 3009 (Federated Suns)

Though the technology is centuries old, VTOL jet boosters—like superchargers—remained an uncommon enhancement for VTOL aircraft, discouraged by manufacturers for the immense stress they created to airframes and rotor assemblies. In more recent times, however, Davion en-

gineers at Cal-Boeing Industries of Dorwinion perfected a means to produce VTOL jet boosters that lessen the stress on the craft for special “sport” VTOLs. Still, very few manufacturers offer or encourage this option in military or civilian applications because of the control issues that arise from the speed boost.

### VTOL JET BOOSTER

**Rules Level:** Experimental

**Available To:** CV, SV

**Tech Base (Ratings):** Both (D/X-F-E)

**Game Rules:** The VTOL Jet Booster enables a VTOL vehicle to move at twice its standard Cruising MP as an enhanced Flanking speed. When engaged (during the unit’s Movement Phase), jet boosters do not require an activation roll, but they do add a +3 target number modifier to any Piloting Skill rolls needed to avoid a sideslip (see p. 68, *TW*). Also, while using jet boosters, a VTOL may not attempt any advanced maneuvers, such as intentional sideslips.

## VTOL MAST MOUNT

**Introduced:** Pre-spaceflight

Used as a means of enhancing the sensor capabilities on scout copters, a mast mount is effectively a sensor extension that rides on a mast extending up from the VTOL’s rotor shaft. This extension allows VTOLs to hover

just below an obstruction and “peek” over it, minimizing their exposure to enemy fire. While uncommon due to the mass they take up in the often-cramped chassis of modern VTOL designs, mast mounts still appear from time to time on reconnaissance units.

### VTOL MAST MOUNT

**Rules Level:** Advanced

**Available To:** CV, SV

**Tech Base (Ratings):** Both (C/F-F-F)

**Game Rules:** A VTOL with a Mast Mount treats any onboard sensors (including active probes and C<sup>3</sup> systems, but not including weapon-like items, such as TAG) as if they are located 1 elevation above the VTOL’s current position. This enables the VTOL to act as a spotter for artillery or indirect LRM fire by other units even if the unit with the Mast Mount is hovering just behind the highest level of a hill, building or other obstruction that would otherwise block its line of sight.

Any damage that hits the VTOL’s rotors automatically destroys the Mast Mount and any sensors mounted in it.

**VTOL Jet Booster:** The VTOL Jet Booster may only be mounted on non fixed-wing VTOL Combat or Support Vehicle, and is placed in the unit’s body. The booster weighs 10 percent of the VTOL’s engine weight (rounded up to the nearest half-ton), and takes up one item slot. A VTOL may mount only 1 jet booster. Jet boosters may not be pod-mounted on OmniVehicles.

**VTOL Mast Mount:** The Mast Mount is available only to VTOL Combat and Support Vehicles. A VTOL unit may carry only one Mast Mount. Weapons may not be mounted in a Mast Mount, which is technically not treated as a location (as it is merely an extension of the rotors) but active probes, C<sup>3</sup> slave units, and ECM systems can be placed in the Mast Mount, essentially placing them “in” the Rotor location.

**Xenoplanetary Condition-Trained Troops:** To create a conventional infantry unit as Xenoplanetary Condition-Trained (XCT) Troops, the unit must select one of the appropriate Infantry Armor types (see *Infantry Armor*, p. 317) for the environment. XCT Troops may be created for Extreme Temperatures, Hazardous Liquids, Vacuum, Trace Atmospheres, and Toxic or Tainted environments.

**Extreme Temperatures (Cold):** XCT Troops equipped for extreme cold must use Snowsuit, Heatsuit, Environment Suit (Hostile or Combat), or Spacesuit (any) armor types.

**Extreme Temperatures (Hot):** XCT Troops equipped for extreme heat must use Cooling Suit (any type), Environment Suit (Hostile or Combat), or Spacesuit (any) armor types.

**Hazardous Liquid Environments:** XCT Troops equipped for hazardous liquids must use Environment Suit (Any), or Engineering Suit armor types.

**Vacuum/Trace Atmospheres:** XCT Troops equipped for vacuum or trace atmosphere levels must use Environment Suit (Hostile or Marine), or Spacesuit (any) armor types.

**Toxic/Tainted Atmospheres:** XCT Troops equipped for toxic or tainted atmosphere conditions must use Environment Suit (Hostile or Marine), or Spacesuit (any) armor types. If the atmosphere is Tainted, but not Toxic, Light Environment Suits may be used instead.

XCT Troops may not be designed as Beast-Mounted or Mechanized (VTOL) infantry if they are to operate in vacuum or trace atmospheres.

Additional construction rules for the required armor types may be found under Infantry Armor (see p. 317).

# XENOPLANETARY CONDITION-TRAINED TROOPS

**Introduced:** Early spaceflight

The wide range of hazardous environments that humans have chosen to live and work in has spawned the development of a special form of combat gear and training specifically tailored to operations within the hazardous environments of non-terrestrial worlds (and often not even on a planetary body at all).

While many special forces receive such specialized training, the most famous troops bearing this title are the five thousand-man volunteer force of the Taurian Concordat's Special Asteroid Support Forces, deployed on zero-G assault platforms stationed throughout the Hyades Cluster's vast asteroid field.

Occasionally referred to more simply as "Hazardous Environment" troops, these specialist forces are more formally referred to as Xenoplanetary Condition-Trained troops, or XCT Troops for short.

## XENOPLANETARY CONDITION-TRAINED (XCT) TROOPS

**Rules Level:** Advanced

**Available To:** CI

**Tech Base (Ratings):** Both (Variable)

**Game Rules:** Conventional Infantry with the appropriate hazardous environment equipment (see the Xenoplanetary Condition-Trained Troops Construction rules, p. 350) may operate in environments where conventional infantry might otherwise be disallowed. All XCT Troops in a given conventional infantry unit must be similarly outfitted to gain this effect, which is cumulative with any infantry armor benefits their hazardous environment gear may apply (see *Infantry Armor*, p. 317). Without the appropriate XCT equipment, infantry may not function in hazardous environments.

In addition, specific types of XCT Troops may receive added effects, based on the environment in question, as follows (this information is also detailed in the Planetary Conditions section; see p. 28):

**Extreme Temperatures:** XCT Troops appropriately equipped for extreme temperatures are unaffected by movement limitations imposed by such conditions.

**Hazardous Liquid Pools:** XCT troops appropriately equipped for Hazardous Liquids divide any damage caused by hazardous liquid pools (see p. 49) by 3, rounding down the result to a minimum of 1.

**Vacuum, Trace, Tainted, or Toxic Atmosphere:** XCT troops appropriately equipped for Vacuum and Trace Atmospheres double all damage sustained in such environments, reflecting otherwise non-lethal damage magnified by suit breaches.

Note that certain Infantry Armor types designed for hazardous environments may modify damage values and such, per *Infantry Armor*, p. 317. XCT Troops outfitted for one environment or condition may not be deployed in another hazardous environment type, but may be deployed in other environments where conventional infantry is allowed.

INTRODUCTION

ADVANCED  
GROUND MOVEMENT

ADVANCED  
COMBAT

ADVANCED  
BUILDINGS

ADVANCED  
SUPPORT  
VEHICLES

GENERAL  
RULES

ADVANCED  
SUPPORT VEHICLE  
CONSTRUCTION

ADVANCED  
WEAPONS  
AND EQUIPMENT

INDEX

RECORD SHEETS

## ALTERNATIVE MUNITIONS

Expanding on the utility of many existing weapon systems, alternative munitions have offered field commanders a broad range of battlefield flexibility since before the days of the OmniMech. Even so, it took the wake of

the Clan invasion to inspire a greater variety of alternative munitions, including specialized rounds for autocannons, artillery, fighter bombs, fluid guns, grenade launchers, missile launchers and mortars.

## AUTOCANNON MUNITIONS

While standard rounds and specialty ammunition such as flechette and armor-piercing shells have gained in popularity among standard and light autocannon users, a number of other special-purpose munitions exist as

well. Indeed, the likes of anti-aircraft flak and tracer ammunition have existed for centuries before the Federated Suns perfected their modern forms of precision and armor-piercing rounds.

### AUTOCANNON MUNITIONS

**Game Rules (General):** Unless otherwise noted, all of the specialty munitions described here may only be employed by standard and light autocannons, and may only be carried by units able to mount such weapons. All specialty ammunition must be purchased in full-ton lots.

If a weapon uses specialty ammunition of any type, the appropriate ammo slot must be declared prior to the start of game play. If no specialty munitions are noted for a given autocannon, the weapon is presumed to be firing standard ammo.

### CASELESS AUTOCANNON AMMO

**R&D Start Date:** 3055 (Federated Commonwealth)

**Prototype Design and Production:** 3056 (Federated Commonwealth)

In an effort to extend the field life of autocannons in battle—especially at the heavier grades, where the shots-per-ton ratios grow extremely restrictive—FedCom engineers considered a large-scale adaptation of caseless ammunition technology, in which the shell's primer and powder is

replaced with a solid propellant that also acts as a “case” for the round. The result—a lighter shell—allowed for more firing rounds per ton than normal autocannons could boast, but forced designers to briefly explore an alternative weapon to handle the munitions. By 3057, they had found a workaround that enabled standard ACs to fire caseless ammunition, but little could be done about the inherent risk of a critical misfeed when firing such rounds.

### CASELESS AUTOCANNON AMMO

**Rules Level:** Experimental

**Tech Base (Ratings):** Inner Sphere (D/X-X-E)

**Game Rules:** Caseless ammunition provides an autocannon with twice the number of shots per ton as an equivalent standard ammo bin. When fired, caseless ammo generates the same heat, reaches the same ranges and delivers the same damage as a standard AC round.

However, on a to-hit roll result of 2 by an autocannon using Caseless AC rounds, the ammo feed breaks down, rendering the weapon useless for the remainder of the scenario. In addition, the shot automatically misses and the controlling player must immediately roll once on the Determining Critical Hits Table, applying all critical hits to the affected autocannon (starting with the uppermost undamaged slot). (Non-Mech/Non-Support Vehicle units that suffer this effect treat the weapon as if it had suffered a Weapon Destroyed critical hit.) This damage reflects a destructive misfeed, rather than an ammunition explosion per se, and MechWarrior or pilot damage will not occur as a result.

Finally, because the feed mechanisms for caseless ammo replace those of standard autocannons, a weapon designated as firing caseless ammo cannot draw from any other alternative ammunition types, even if they would otherwise be compatible with the autocannon.

### FLAK AUTOCANNON AMMO

**Introduced:** circa 2310 (Terran Hegemony)

Despite having been a proven technology in ages past, flak autocannon ammunition remains uncommon today. Intended to deal with airborne combatants such as VTOLs and fighters, this ammunition uses proximity

charges to detonate in mid-air. While potent against fast-moving targets susceptible to foreign object damage (FOD), flak ammo is less effective against slower-moving targets on the ground because the charges scatter their shrapnel too far and too quickly to benefit from the target's mobility.

### FLAK AUTOCANNON AMMO

**Rules Level:** Advanced

**Tech Base (Ratings):** Both (B/E-F-F)

**Game Rules:** Flak ammunition provides an autocannon with the same number of shots per ton as an equivalent standard ammo bin. When fired, flak ammo generates the same heat and reaches the same ranges as a standard AC round, but only inflicts full damage when used to deliver a flak attack against airborne VTOLs and aerospace units (using the rules on p. 114, *TW*), or when fired against conventional infantry. Against all other units—including battle armored infantry and grounded aerospace units—flak AC ammo inflicts half its normal rated damage.

## TRACER AUTOCANNON AMMO

**Introduced:** circa 2300 (Terran Hegemony)

Once a favored ammunition type used to help coordinate massed fire in nighttime conditions, self-illuminating “tracer” rounds sacrificed a small amount of hitting power in favor of target-illuminating shots that were

carefully interspersed throughout each burst of weapon fire. Centuries of preference for cheap, maximized damage potential led to the evaporation of tracer ammo from most autocannons, to the point where modern ACs may spit out one tracer (if any) for every 50 bursts fired.

## TRACER AUTOCANNON AMMO

**Rules Level:** Advanced

**Tech Base (Ratings):** Both (B/D-E-F)

**Game Rules:** Tracer ammunition provides an autocannon with the same number of shots per ton as an equivalent standard ammo bin. When fired, tracer ammo generates the same heat, and reaches the same ranges as a standard AC round, but inflicts 1 point less damage per shot (to a minimum of 1 point). Autocannons firing tracer ammo reduce their to-hit modifiers for night combat to +1 (rather than +2) and eliminate any dusk/dawn modifiers.

# ARTILLERY MUNITIONS

With the renaissance of Star League technology during the past couple of decades, many militaries have developed numerous variant rounds for the once sporadically used artillery pieces scattered around the Inner

Sphere. Though the Arrow IV artillery missile has proven a favorite weapon for such enhancements, conventional tube artillery have also benefited from recent attention.

## ARTILLERY MUNITIONS

**Game Rules (General):** Each of the munitions described here will identify which standard artillery weapons and/or Arrow IV artillery missile launchers may employ such specialty ammo in game play. Artillery cannons may not fire any of these specialty rounds. All specialty artillery ammunition must be purchased in full-ton lots.

If a weapon uses specialty munitions of any type, the appropriate ammo slot must be declared prior to the start of game play. If no specialty munitions are noted for a given artillery system, the weapon is presumed to be firing its standard “high-explosive” rounds (or, in the case of Arrow IV artillery missile launchers, homing missile rounds).

## AIR-DEFENSE ARROW (ADA) MISSILES

**R&D Start Date:** 3066 (Capellan Confederation)

**Prototype Design and Production:** 3068 (Capellan Confederation)

Air-defense arrow (ADA) missiles were field-tested by the Capellan Confederation to defend against Duke Hasek’s aerospace forces during

Operation Sovereign Justice, and since have seen action against the Word of Blake as well. So far, however, only Death Commando units have been observed using this experimental missile with their Arrow IV launchers.

## AIR-DEFENSE ARROW (ADA) MISSILES

**Rules Level:** Experimental

**Tech Base (Ratings):** Inner Sphere (E/X-X-F)

**Game Rules:** Only ground- or naval-based units (including both surface vehicles and submarines) may fire ADA Missiles from any on-board Arrow IV artillery missile launchers. Aerospace units and airborne units (including VTOL vehicles and Airship, Fixed-Wing or Satellite Support Vehicles) may not use ADA Missiles.

An Arrow IV launcher using ADA Missiles may make a ground-to-air attack against any airborne unit within 2 hexes of the attacker on the Low Altitude Map (or 2 ground mapsheets), unless the target is higher than 8 Altitude (2,000 meters; see pp. 80-81, *TW* for information on Low-Altitude Movement). ADA Missiles follow the rules for a standard flak attack (see p. 114, *TW*), but replace the relevant range modifiers as follows: If the aerospace unit is operating in the same low-altitude hex/over the same ground mapsheet as the firing unit, the attack is considered to be at short range; if the target is 1 low-altitude hex/1 ground mapsheet away from the launching unit, a medium-range modifier applies; at 2 low-altitude hexes/ground-scale mapsheets away, the attack is considered to be long range. (Remember that a ground mapsheet is equal to 17 hexes in distance.)

A unit making a ground-to-air attack using ADA Missiles may make no other attacks in the same turn against secondary targets on the ground.

## ARROW IV HOMING MISSILES

**Introduced:** 2600 (Terran Hegemony)

**Extinct:** 2830 (Inner Sphere)

**Recovered:** 3045 (Capellan Confederation)

The Arrow IV homing missile is, in essence, an enhanced laser-guided variation on the standard Arrow IV missile. Originally designed for the first

Star League as an ECM-proof precision artillery weapon, the Arrow IV works in conjunction with target acquisition gear (TAG) to home in on targeted units using the missile’s own passive internal sensors, and then deliver a devastating attack. During the Star League era, homing missiles were the munition of choice for the Arrow IV.

INTRODUCTION

ADVANCED  
GROUND MOVEMENT

ADVANCED  
COMBAT

ADVANCED  
BUILDINGS

ADVANCED  
SUPPORT  
VEHICLES

GENERAL  
RULES

ADVANCED  
SUPPORT VEHICLE  
CONSTRUCTION

ADVANCED  
WEAPONS  
AND EQUIPMENT

INDEX

RECORD SHEETS

## ARROW IV HOMING MISSILES



**Rules Level:** Advanced

**Tech Base (Ratings):** Both (E/E-F-E)

**Game Rules:** Only units carrying an Arrow IV artillery missile launcher may carry Arrow IV Homing Missiles.

An attack using an Arrow IV Homing Missile is treated as standard artillery weapon attack (see p. 179), with the following exceptions:

- The Arrow IV Homing Missile does not make its own to-hit roll. Instead, the homing missile may only attack units that have been successfully designated by a friendly TAG unit in the turn of the missile's arrival. If there are no successfully TAG-designated targets on the board when the missile arrives, the homing missile explodes harmlessly. (Undirected or misdirected Arrow IV Homing Missiles do not scatter.)
- If multiple units are successfully designated by friendly TAG on the turn of an Arrow IV Homing Missile's arrival, the player controlling the unit which fired the round must choose which target the missile will attack.
- When attacking a successfully designated target, the player controlling the missile launcher must roll 2D6. On a result of 4+, the missile hits the target with its full rated damage. This is treated as a hit from a direct-fire ballistic weapon, resolved against the unit's facing relative to the TAG unit that designated it. An additional 5 points of artillery damage applies to all other units in the target's hex (treated as an area-effect weapon, if these other units include infantry). If the missile's 2D6 roll is 3 or less, however, the missile hits the hex itself, and inflicts 5 points of area-effect damage to all units in the target's hex (including the target).
- A friendly TAG may designate targets for any number of Arrow IV Homing Missiles per round, with only one to-hit roll required to designate the target. However, a TAG-equipped unit may not designate multiple targets in a turn. If an on-board Arrow IV launcher using homing missiles also mounts TAG, the unit may designate a target and fire its homing missiles against it in the same turn.

## ARROW IV NON-HOMING MISSILES

**Introduced:** 2600 (Terran Hegemony)

**Extinct:** 2830 (Inner Sphere)

**Recovered:** 3044 (Capellan Confederation)

The non-homing variety of Arrow IV artillery missiles offered a less expensive, unguided alternative to Star League field commanders. Considered

by some a waste of the Arrow's main potential, these missiles were not used as widely as homing rounds, but their less sophisticated nature made them the first Arrow IV munitions the Inner Sphere produced when the launcher's technology was recovered in the mid-3040s.

## ARROW IV NON-HOMING MISSILES



**Rules Level:** Advanced

**Tech Base (Ratings):** Both (E/E-F-E)

**Game Rules:** Only units carrying an Arrow IV artillery missile launcher may carry Arrow IV Non-Homing Missiles.

Arrow IV Non-Homing Missiles function as standard artillery weapons in game play, with all appropriate modifiers and rules applied, including scatter effects. An Arrow IV Non-Homing Missile delivers its damage as a standard artillery attack (see p. 179). This damage is treated as standard area-effect damage.

## CLUSTER ARTILLERY/ARROW MISSILES

**Introduced:** Pre-spaceflight ([Artillery]), 2620 (Terran Hegemony [Arrow])

**Extinct:** 2830 (Inner Sphere [Arrow])

**Recovered:** 3047 (Capellan Confederation [Arrow])

Cluster artillery (and its Arrow IV missile variant) is a variation on standard

artillery shells and non-homing missiles, which deliver a low-altitude airburst designed to rain miniature bomblets. This delivery approach enables an attacker to hit targets that have taken refuge within built-up terrain, such as trenches and fieldworks.

## CLUSTER ARTILLERY/ARROW MISSILES



**Rules Level:** Advanced

**Tech Base (Ratings):** Both (E/E-F-E)

**Game Rules:** Cluster Artillery rounds are available only for the Arrow IV artillery missile launcher and the Long Tom, Thumper, and Sniper artillery pieces.

Cluster Artillery munitions function as standard artillery in game play, with all appropriate modifiers and rules applied, including scatter effects. However, damage from Cluster Artillery or Cluster Arrow missiles is applied differently, as follows:

- Against any infantry unit not inside a building, damage from Cluster Artillery or Cluster Arrow munitions is applied as though the unit is in open terrain, regardless of the actual terrain or the construction of fieldworks and trenches.
- Against 'Mech units, the attack is resolved using the Shot from Above Table (see p. 175, *TW*). Against landed aerospace units, the attack is resolved using the Above/Below column of the appropriate Hit Location Tables. Against vehicle units, the attack is resolved using the Front column of the appropriate Hit Location Table, but with a +2 modifier applied to the result (any result over 12 is treated as a 12).
- Units within a building in a hex struck by Cluster Artillery or Cluster Arrow munitions are protected from damage (though the buildings themselves are not, and may collapse per normal rules).

## COPPERHEAD ARTILLERY

**Introduced:** 2645 (Terran Hegemony)

**Extinct:** 2825 (Inner Sphere)

**Recovered:** 3051 (Capellan Confederation)

A sophisticated alternative to standard artillery rounds, Copperhead munitions are effectively a tube artillery adaptation of the Arrow IV homing

missile. Rare even during the Star League period, simply because the Arrow IV launch system was much more portable, Copperheads made a return in the Inner Sphere when Capellan weapons designers sought an alternative means of delivering Arrow IV homing rounds beyond laser-guided bombs and their still-limited supply of Arrow launchers.

## COPPERHEAD ARTILLERY

**Rules Level:** Advanced

**Tech Base (Ratings):** Both (E/E-F-F)

**Game Rules:** Copperhead Artillery rounds are available for the Long Tom, Thumper, and Sniper artillery pieces only.

Copperhead Artillery munitions function as Arrow IV homing missiles (see p. 354), with all appropriate modifiers and rules applied. The base damage values for Copperhead rounds are listed in the Artillery Ordnance Table (see p. 184).

## FLECHETTE ARTILLERY

**Introduced:** Pre-spaceflight

Flechette artillery shells are designed for maximum anti-infantry work. Proximity-fused to detonate just before impact, these shells shower a wide area with dart-like metal flechettes that do little damage to armored units,

but can kill or incapacitate a large number of conventional infantry. Use of this artillery munition was banned in the Star League era, but many nations have returned to using these deadly shells in modern times.

## FLECHETTE ARTILLERY

**Rules Level:** Advanced

**Tech Base (Ratings):** Both (E/F-F-E)

**Game Rules:** Only units carrying a Sniper, Thumper, or Long Tom artillery piece may carry Flechette Artillery rounds.

Flechette Artillery rounds function as standard artillery weapons in game play, with all appropriate modifiers and rules applied, including scatter effects. However, Flechette ammunition uses the following rules upon a successful attack:

- Flechette shells inflict no armor damage against any armored unit with a BAR of 5 or higher (including battle armor, 'Mechs, ProtoMechs, most vehicles, aerospace units and Mobile Structures). However, for all vehicles with a Wheeled or Hover motive system within a Flechette round's area of effect, the Attacker must make a roll on the appropriate vehicle's Motive System Damage Table (see p. 193, *TW*).
- Against Support Vehicles with a BAR of 4 or less, Long Tom-fired Flechette Artillery rounds inflict 5 points of damage for every point of BAR below 5, a Sniper-fired Flechette round inflicts 3 points of damage per point of BAR below 5, while a Thumper-fired Flechette round inflicts 1 point of damage per point of BAR below 5. (For example, a unit with a BAR of 4 suffers 3 points of damage from a Sniper Flechette round  $[(5 - 4) \times 3 = 3 \text{ points}]$ , while a unit with a BAR of 2 suffers 15 from a Long Tom's Flechette round  $[(5 - 2) \times 5 = 15 \text{ points}]$ .) This damage is applied to the unit in 5-point clusters as standard artillery damage (see p. 182).
- Against conventional infantry, Long Tom-fired Flechette Artillery inflicts a base damage of 4D6 to all units in the target hex and 2D6 to units in the adjacent hexes. Sniper-fired Flechette rounds inflict 2D6 to units in the central hex and 1D6 to units in the adjacent hexes. Thumper-fired Flechette rounds inflict 2D6 to units in the target hex; no damage is applied to any adjacent hexes. Per the area-effect rules (see p. 113, *TW*) this base damage is doubled against conventional infantry units, and doubled again against such units if they are located in clear terrain.

## ILLUMINATION ARTILLERY/ARROW MISSILES

**Introduced:** Pre-spaceflight ([Artillery]), 2621 (Terran Hegemony [Arrow])

**Extinct:** 2831 (Inner Sphere [Arrow])

**Recovered:** 3047 (Capellan Confederation)

Artillery illumination rounds (and their Arrow-launched cousins) effectively deliver a cluster of high-intensity flares suspended by miniature parachutes over a target area. Used to reveal and mark enemy positions during night or near-night combat, use of these rounds is relatively common in modern warfare.

## ILLUMINATION ARTILLERY/ARROW MISSILES

**Rules Level:** Advanced

**Tech Base (Ratings):** Both (C/D-D-D)

**Game Rules:** Illumination rounds are available only for the Long Tom, Thumper, and Sniper artillery pieces and the Arrow IV missile launcher.

All Illumination rounds (including the Arrow IV missile version) function like standard non-homing artillery munitions (see p. 354), with all appropriate modifiers and rules applied. However, instead of inflicting damage, Illumination rounds negate any nighttime, dusk or dawn to-hit modifiers against units within their area of effect (see the Artillery Ordnance Table, p. 184).

INTRODUCTION

ADVANCED  
GROUND MOVEMENT

ADVANCED  
COMBAT

ADVANCED  
BUILDINGS

ADVANCED  
SUPPORT  
VEHICLES

GENERAL  
RULES

ADVANCED  
SUPPORT VEHICLE  
CONSTRUCTION

ADVANCED  
WEAPONS  
AND EQUIPMENT

INDEX

RECORD SHEETS

## LASER-INHIBITING (LI) ARROW MISSILES

**R&D Start Date:** 3052 (Federated Commonwealth)

**Prototype Design and Production:** 3053 (Federated Commonwealth)

An experimental weapon first conceived at the peak of the Clan invasion, this NAIS-inspired specialty Arrow IV ammunition was discarded for

its limited usefulness (as well as a series of problems with the weapon development program and the scientists assigned to it). This missile releases a special chemical “fog” that scatters laser energy, but proved ineffective against particle weapons, ballistics, flamers and missiles.

## LASER-INHIBITING (LI) ARROW MISSILES

**Rules Level:** Experimental

**Tech Base (Ratings):** Inner Sphere (E/X-X-F)

**Game Rules:** Only units carrying an Arrow IV artillery missile launcher may carry Laser-Inhibiting Arrow IV Missiles.

Laser-Inhibiting Arrow IV rounds are delivered in the same fashion as conventional artillery (see p. 179), with the following differences:

- Rather than delivering damage, LI Arrow Missiles fill the target hex and the six surrounding hexes with a specialized smoke round (treated as Light Smoke; see p. 47) that rises 2 levels above the underlying terrain (or surface level, if the target is a water hex) and lasts until the End Phase of the turn following the weapon’s attack.
- Any attack by all laser weapons that passes through a Laser-Inhibiting smoke hex reduces its damage by 2 points per hex of “interference” (to a minimum of 0).

## INFERNO-IV MISSILES

**Introduced:** 3055 (Capellan Confederation)

Based on the recovered “Thunder” FASCAM concept, the Capellan Confederation explored alternative minefield munitions in their own applications, eventually leading to the development of active and vibrobomb FASCAM

rounds via Arrow IV launchers. Before this, however, they introduced the half-successful Inferno-IV missile system. Initially planned to deploy their newly invented Inferno mines, the more volatile mines tended instead to ignite on impact, producing instant, widespread fires.

## INFERNO-IV MISSILES

**Rules Level:** Advanced

**Tech Base (Ratings):** Inner Sphere (C/X-X-D)

**Game Rules:** Only units carrying an Arrow IV artillery missile launcher may carry Inferno-IV Missiles.

Inferno-IV Arrow rounds are delivered in the same fashion as conventional artillery (see p. 179), with the following differences:

- Rather than delivering damage directly, Inferno-IV Missiles fill the target hex and all adjacent hexes with fire (see p. 43). Units within a hex when it is struck by an Inferno-IV round suffer the effects of being hit by 5 Inferno missiles (see p. 141, *TW*). Units passing through a hex ignited by Inferno-IV Missiles suffer effects as described under the standard fire rules (see p. 43).
- Hexes struck by Inferno-IV Missiles continue to burn (and generate smoke, see p. 45) for the remainder of a scenario, unless doused by an appropriate anti-flame system (such as sprayers and fluid guns loaded with using water, coolant or flame-retardant ammo).
- Heat-tracking units carrying Inferno-IV munitions are susceptible to Inferno ammunition explosions from overheating (see pp. 141-142, *TW*).

## SMOKE ARTILLERY/ARROW MISSILES

**Introduced:** Pre-spaceflight

Developed over a millennium ago, artillery-delivered smoke rounds have changed little since their inception, allowing armies to produce “mobile cover” that can be used to obscure their movements and activities during battle.

## SMOKE ARTILLERY/ARROW MISSILES

**Rules Level:** Advanced

**Tech Base (Ratings):** Both (B/A-A-A)

**Game Rules:** Any conventional artillery weapon or the Arrow IV missile launcher may carry and fire Smoke rounds instead of their normal munitions.

Artillery Smoke rounds are unguided munitions, regardless of the artillery weapon type used to deliver them. They are fired per the normal artillery rules (see p. 179). Rather than inflicting damage, artillery Smoke rounds fill the target hex and all adjacent hexes with heavy smoke (see p. 46) that rises 2 levels above the underlying terrain.

Artillery smoke dissipates in the End Phase of the third turn after the attack.

## THUNDER (FASCAM) ARTILLERY/ARROW MISSILES

**Introduced:** 2621 (Terran Hegemony)

**Extinct:** 2833 (Inner Sphere)

**Recovered:** 3051 (Capellan Confederation ["Thunder" FASCAM])

**Introduced:** 3065 (Capellan Confederation [Active and Vibrabomb-IV])

Initially developed by the Terran Hegemony and maintained by the Clans (though they only sporadically used them), field artillery scattering

mine (FASCAM) "Thunder" munitions deploy conventional minefields via traditional indirect-fire delivery systems such as LRMs, standard artillery and Arrow IV artillery missiles. With the arrival of the Clans, Capellan weapon designers raced to revive this technology for their own use, and later moved beyond it to introduce active and vibrabomb-based FASCAM launchers in 3056.

### THUNDER (FASCAM) ARTILLERY/ARROW MISSILES

**Rules Level:** Advanced

**Tech Base (Ratings):** Clan (C/X-D-D [FASCAM only]), Inner Sphere (C/E-X-E [FASCAM]; D/X-X-E [Active-IV, Vibrabomb-IV])

**Game Rules:** Only units carrying an Arrow IV artillery missile launcher may carry Thunder (FASCAM) Active-IV or Vibrabomb-IV Missiles. Only units carrying a conventional artillery weapons may carry artillery FASCAM shells.

FASCAM rounds of all types (including Active-IV and Vibrabomb-IV types) are delivered in the same fashion as conventional artillery (see p. 179), with the following differences:

- Rather than delivering damage, FASCAM rounds fill the target hex with mines (see p. 207). Units within a hex when it is struck by a FASCAM round may exit the hex without setting off the minefields they lay, but all other units entering or passing through a mined hex follow the standard rules for the appropriate minefield (see p. 207).
- The density of a minefield delivered by conventional artillery weapons is equal to the artillery weapon's normal central-hex damage (so a Sniper-fired FASCAM round delivers a 20-point density minefield, while a Long Tom's minefield has a 25-point density value). Arrow IV-delivered minefields have a density of 30 points. These minefields cannot combine with other weapon-delivered minefields to increase their densities. The one exception is if such artillery-laid minefields are placed in a hex with a pre-designated minefield of the same type from the start of the game, in which case the minefield density can be up to 30-points (i.e. an Arrow IV-delivered minefield will never combine with any type of minefield as the 30-point density cannot be exceeded).
- Once deployed, minefields delivered by any appropriate weapon system function in accordance with their standard game rules (standard FASCAM mines use the standard (conventional) minefield rules; Active-IV mines use the active minefield rules; Vibrabomb-IV mines use the vibrabomb minefield rules).

## BOMB MUNITIONS

The preferred method for air-to-ground attacks, bombs have always come in a wide variety of types and styles, allowing an airborne unit many different choices in how to attack an enemy formation. Lately,

more external air-to-air ordnance has been making an appearance in the battlefield, allowing even smaller fighters a better chance against their heavier brethren.

### BOMB MUNITIONS

**Game Rules (General):** Unless otherwise noted, only Conventional Fighters, Aerospace Fighters and flight-capable vehicles equipped with external bomb mounts (hardpoints) may carry any of the specialty ordnance described here. The same rules apply for carrying bombs.

Applicable units must designate their bomb types prior to the start of game play. If no specialty ordnance is noted for a given bomb, it is presumed to be a standard high-explosive bomb.

## AIR-TO-AIR ARROW (AAA) MISSILES

**Introduced:** 3072 (Lyran Alliance, Clan Wolf [in-Exile])

Attempting to bolster their aerospace strength against Word of Blake and Jade Falcon invaders, the Lyran Alliance and Clan Wolf (in Exile) mutually

developed a new externally mounted Arrow IV missile variant specifically designed to enable aerospace fighters to attack other airborne units.

### AIR-TO-AIR ARROW (AAA) MISSILES

**Rules Level:** Advanced

**Tech Base (Ratings):** Both (E/X-X-F)

**Game Rules:** Air-to-Air Arrow missiles take up 5 bomb slots per missile when mounted on an external hardpoint (and are unavailable for use by standard Arrow IV launchers).

AAA Missiles may be used by aerospace units traveling at any altitude on the Low-Altitude Map, on any Row on the High-Altitude Map or the Space Map, and may attack any target except for infantry. If used against targets on the ground, such as when engaging in combat over the ground mapsheet (see p. 242, *TW*), AAA missiles suffer a +4 to-hit modifier, plus an additional +3 if fired at a ground target from below an Altitude of 4 (150 meters or less from the ground, per p. 82, *TW*). AAA Missiles may not cross the Space/Atmosphere Interface.

Unlike a standard bomb attack, AAA Missiles attack as a standard direct-fire weapon, and deliver their damage to a single hit location.

Anti-missile systems and other Point Defense weapons affect the AAA Missile as a capital missile (see p. 130, *TW*).

INTRODUCTION

ADVANCED  
GROUND MOVEMENT

ADVANCED  
COMBAT

ADVANCED  
BUILDINGS

ADVANCED  
SUPPORT  
VEHICLES

GENERAL  
RULES

ADVANCED  
SUPPORT VEHICLE  
CONSTRUCTION

ADVANCED  
WEAPONS  
AND EQUIPMENT

INDEX

RECORD SHEETS

## ANTI-SHIP (AS) MISSILES

**R&D Start Date:** 3069 (Federated Suns)

**Prototype Design and Production:** 3071 (Federated Suns)

A crash program devised by the Federated Suns with an ultimate goal of breaking naval blockades such as the Word's group over New Avalon, the anti-ship (AS) missile is another Arrow-style external ordnance based on the much smaller tandem-charge SRM. Fitted with extra boosters for enhanced

acceleration and kinetic energy, the AS missile is designed to attain incredible velocities so as to achieve armor penetration as much through sheer kinetics as through the detonation of its dual warhead. Lacking a sophisticated guidance system, however, the missile's enhanced speed is as much a hindrance as a boon, making it far more effective against larger and more ponderous targets than smaller, nimbler ones.

## ANTI-SHIP (AS) MISSILES

**Rules Level:** Experimental

**Tech Base (Ratings):** Inner Sphere (D/X-X-F)

**Game Rules:** Bulky, because of their booster engines, Anti-Ship Missiles take up 6 bomb slots per missile when mounted on an external hardpoint (and are unavailable for use by standard Arrow IV launchers).

Anti-Ship Missiles function in the same fashion as an Air-to-Air Arrow Missile (see p. 357), with the following exceptions:

- When an AS Missile delivers a successful attack, it inflicts 3 points of capital-scale damage (30 standard-scale damage) to the target's armor; in addition, the Attacker rolls for a penetrating critical hit as a Barracuda missile.
- AS Missiles suffer a +4 to-hit modifier against any unit lighter than 500 tons, and may not target ground units weighing 100 tons or less. Against targets 500 tons and up (or against buildings, Mobile Structures and terrain hexes), the AS Missile suffers no such modifier.
- AS Missiles may only be used by units traveling in space, or at Altitude 3 or higher on the Low-Altitude Map.
- Anti-Ship Missiles are affected by Point Defense systems in the same manner as Capital Missiles.

## ANTI-SHIP ELECTRONIC WARFARE (ASEW) MISSILES

**R&D Start Date:** 3065 (Lyran Alliance)

**Prototype Design and Production:** 3067 (Lyran Alliance)

With one of the smallest fleets of the Inner Sphere powers, Lyran weapon designers conceived of the anti-ship electronic warfare (ASEW) missile as a means of leveling the playing field against capital ships. Based on the screen

launcher, prototypes of this experimental weapon were undergoing testing in the days prior to the Jihad. Though mainstream production never began, samples of this weapon system somehow fell into the hands of Alys Rousset-Marik's resistance movement in the Blakist controlled Free Worlds League, where they have been used to aid in raids against larger ships.

## ANTI-SHIP ELECTRONIC WARFARE (ASEW) MISSILES

**Rules Level:** Advanced

**Tech Base (Ratings):** Inner Sphere (E/X-X-E)

**Game Rules:** ASEW Missiles take up 6 bomb slots per missile when mounted on an external hardpoint (and are unavailable for use by standard Arrow IV launchers).

ASEW Missiles function in the same fashion as an Air-to-Air Arrow Missile (see p. 357), with the following exceptions:

- When an ASEW Missile delivers a successful attack, it inflicts no damage to the target. Instead, it imposes a +4 modifier to all weapon attacks made by the target vessel by weapons whose arcs cover the hexside where the ASEW hit. In the event of a hit that falls on a line, the defender chooses which hexside is affected. (For example, if an ASEW hits a WarShip through the fore-left hexside, all fore-left and left broadside weapons suffer +4 modifiers, but the nose, aft-left, aft, and all right-side weapons remain unaffected.) These effects begin at the end of the Weapon Attack Phase and last until the End Phase of the turn after the attack.
- Any Naval C<sup>3</sup> or Naval Comm-Suite systems on a target unit struck by an ASEW Missile are rendered ineffective, and any attempt to jump will be delayed—but not aborted—while the electronic static clears. These effects last until the End Phase of the turn after the attack.
- ASEW Missiles suffer a +4 to-hit modifier against any unit lighter than 500 tons.
- Units traveling within an atmosphere or on the Space/Atmosphere Interface may not launch ASEW Missiles.

## ARROW IV HOMING MISSILES (AIR-LAUNCHED VERSION)

**Introduced:** 2600 (Terran Hegemony)

**Extinct:** 2830 (Inner Sphere)

**Recovered:** 3047 (Capellan Confederation)

Originally devised as a companion to the conventional Arrow IV launcher-based missiles of the day, the air-launched rendition of the Arrow IV homing

missile was recovered by Capellan weapon designers in 3047, to make up for the fact that their recovered launchers were still in short supply. Carried as external ordnance, the air-launched Arrow IV homing missile proved an elegant solution, enabling fighters to provide precision-guided support fire against a target.

## ARROW IV HOMING MISSILES (AIR-LAUNCHED VERSION)

**Rules Level:** Advanced

**Tech Base (Ratings):** Both (E/E-F-E)

**Game Rules:** These are dropped as bombs, not fired as artillery and so they do not use the Airborne Targeting rules (see p. 180). Air-launched Arrow IV Homing Missiles occupy 5 bomb slots per missile and function in the same manner as their standard launcher-based version (see p. 355), with the following modifications:

- Air-launched Arrow IV Homing Missiles may not be used to attack other airborne aerospace units or any target in space.
- Air-launched Arrow IV Homing Missiles may not be fired by units at an Altitude of 3 or lower on the Low-Altitude Map.
- Unlike ground-based Arrow launchers, an aerospace unit may not TAG and fire its Arrow IV Homing Missile at the same time. However, a fighter using air-launched Arrow IV Homing Missiles can release these missiles in a turn prior to the missiles' arrival on the target mapsheet, and in that subsequent turn over-fly the intended target using TAG systems on board to designate the target.

## ARROW IV NON-HOMING MISSILES (AIR-LAUNCHED VERSION)

**Introduced:** 2623 (Terran Hegemony)

**Extinct:** 2859 (Inner Sphere)

**Recovered:** 3046 (Capellan Confederation)

Like its homing missile counterpart, the non-homing air-launched Arrow IV munition was made as a complement to the air-launched homing mis-

sile. Lost in the decades after the fall of the Star League, this ordnance was also recovered by Capellan weapon designers in the mid-3040s, though its enormous drag compared to conventional high-explosive bombs made it an unpopular weapon choice, which remains little used to this day.

## ARROW IV NON-HOMING MISSILES (AIR-LAUNCHED VERSION)

**Rules Level:** Advanced

**Tech Base (Ratings):** Both (E/E-F-E)

**Game Rules:** These are dropped as bombs, not fired as artillery and so they do not use the Airborne Targeting rules (see p. 180). Air-launched Arrow IV Non-Homing Missiles occupy 5 bomb slots per missile and function in the same manner as their standard launcher-based version (see p. 354), except that air-launched Arrow IV Non-Homing Missiles may not be fired by units at an Altitude of 3 or lower on the Low-Altitude Map.

## INFERNO BOMBS

**Introduced:** Pre-spaceflight

Long before Inferno SRMs or their artillery-launched cousins came into play, fighters carried incendiary bombs to wreak havoc on enemy conventional formations (or to act as a kind of "instant defoliant" for heavily forested

or jungle areas). Today's Inferno bombs are not that far removed from those early napalm weapons, but remain less common in air-to-ground combat than high-explosive bombs.

## INFERNO BOMBS

**Rules Level:** Advanced

**Tech Base (Ratings):** Both (B/D-D-D)

**Game Rules:** Inferno Bombs follow all the same rules for bombing (see pp. 245-247, *TW*), except that instead of delivering explosive damage directly, Inferno Bombs instantly create a fire in the target hex (even if it is open water). Units within a hex when it is struck by an Inferno Bomb suffer the effects of being hit by 5 Inferno missiles (see p. 141, *TW*). Units passing through a hex ignited by Inferno Bombs suffer effects as described under the standard fire rules (see p. 43).

Hexes struck by Inferno Bombs continue to burn (and generate smoke) for 30 turns unless doused by an appropriate anti-flame system (such as sprayers and fluid guns loaded with water, coolant or flame-retardant ammo).

## LIGHT AIR-TO-AIR (LAA) MISSILES

**Introduced:** 3072 (Free Worlds League)

Not quite as potent as the air-to-air Arrow missiles introduced by the Lyrans and the Wolves, this much smaller air-to-air missile version had its debut with the allied aerospace forces of the Duchy of Tamarind and Duch-

ess Alys Rousset-Marik's resistance movement. Built smaller and leaner, these so-called light air-to-air (LAA) missiles can be carried by smaller fighters and create far less drag during atmospheric operations.

## LIGHT AIR-TO-AIR (LAA) MISSILES

**Rules Level:** Advanced

**Tech Base (Ratings):** Both (E/X-X-F)

**Game Rules:** Light Air-to-Air Arrow Missiles take up 1 bomb slot per missile when mounted on an external hardpoint.

LAA Missiles otherwise follow the same rules as Air-to-Air Arrow Missiles (see p. 357).

INTRODUCTION

ADVANCED  
GROUND MOVEMENT

ADVANCED  
COMBAT

ADVANCED  
BUILDINGS

ADVANCED  
SUPPORT  
VEHICLES

GENERAL  
RULES

ADVANCED  
SUPPORT VEHICLE  
CONSTRUCTION

ADVANCED  
WEAPONS  
AND EQUIPMENT

INDEX

RECORD SHEETS

## THUNDER (FASCAM) BOMBS

**Introduced:** 2623 (Terran Hegemony)

**Extinct:** 2840 (Inner Sphere)

**Recovered:** 3052 (Capellan Confederation ["Thunder" FASCAM])

**Introduced:** 3065 (Capellan Confederation [Active and Vibrabomb])

The air-dropped equivalent to Thunder (FASCAM) artillery and Arrow IV munitions, "Thunder" FASCAM bombs share a nearly identical history with their Arrow-delivered cousins. Returned to popularity since the Clan invasion, these minefield-laying bombs have become a useful means for "herding" enemy troops into bottleneck positions and ambushes.

### THUNDER (FASCAM) BOMBS

**Rules Level:** Advanced

**Tech Base (Ratings):** Clan (C/X-D-D [FASCAM only]), Inner Sphere (C/E-X-E [FASCAM]; D/X-X-E [Active, Vibrabomb])

**Game Rules:** Thunder (FASCAM) bombs follow the same rules for bombing (see pp. 245-247, *TW*), with the following exceptions:

- Minefields delivered by Thunder (FASCAM) Bombs may be designated as standard land-based minefields, standard sea-based minefields, active landmine fields or vibrabomb landmine fields. If the type is not specified prior to play, but the bomb is designated as a Thunder bomb, the minefield type is a standard (conventional) landmine field.
- Instead of delivering explosive damage directly, Thunder bombs create a 20-point density minefield in the target hex and all adjacent hexes. (If the affected terrain is water and the minefield is land-based, the mines sink to the floor of the water feature; if the affected terrain is water and the mines are sea-based, they float on the water's surface; sea-type mines deployed on land fail to operate.) While this minefield cannot be combined with any other weapon-delivered minefields to increase a minefield density, if it is laid in a hex with a pre-determined minefield laid at the start of the game and is the same minefield type, the total density of the minefield can be 30-point density.
- Units within a hex when it is struck by a FASCAM round may exit the hex without setting off the minefields, but all other units entering or passing through a mined hex follow the standard rules for the appropriate minefield (see p. 207).
- Once deployed, minefields delivered by Thunder bombs function in accordance with their standard game rules (standard FASCAM land-mine bombs use the standard (conventional) land-based minefield rules; standard FASCAM sea mines use the standard sea-based minefield rules; Thunder-active mines use the active minefield rules; Thunder-vibrabomb mines use the vibrabomb minefield rules).

## TORPEDO BOMBS

**Introduced:** Pre-spaceflight

A classic weapon dating back to the early twentieth century, torpedo bombs are anti-maritime weapons, designed to penetrate the water's surface and withstand increasing water pressures to deliver strikes below a

vessel's waterline. Though modified through the ages, the principles behind the torpedo bomb remain the same, even though maritime combat has virtually become a thing of the past.

### TORPEDO BOMBS

**Rules Level:** Advanced

**Tech Base (Ratings):** Both (B/C-C-C)

**Game Rules:** Torpedo Bombs follow all the rules for bombing (see pp. 245-247, *TW*), with the following exceptions:

- Unlike most bombs, Torpedo Bombs target units rather than hexes, and thus take target movement modifiers into account when delivering an attack.
- Torpedo Bombs dropped against targets not located under or on the surface of water inflict only half their damage (round down).
- Torpedo Bombs can target surface naval vessels and other vehicles coasting on the surface of a water feature—including hydrofoils, WiGEs floating on the surface or "flying" at water level (as opposed to 1 level above it) and hovercraft. They can also target any submerged unit to a maximum of Depth 50 below the water's surface.
- If a Torpedo Bomb attack is successful, the weapon inflicts its full damage against the targeted unit, and applies a +1 modifier to the subsequent Hull Breach roll. If the target is a surface-skimming unit (hydrofoil, hovercraft or WiGE), apply this modifier instead to the roll for any Motive System critical hit checks.

## FLAMER/FLUID GUN/SPRAYER AMMUNITION

While a staggeringly broad range of fluid types are available and suitable for use by vehicular-scale flamers, fluid guns, and sprayers many can be defined in basic terms. Whatever the combinations, these alternative "am-

munition" options for such equipment may be used to hose down targets with everything from coolants, incendiaries, and fire-retardant foam to corrosive chemicals, oils, paints and even water.

### FLAMER/FLUID GUN/SPRAYER AMMUNITION

**Game Rules (General):** Only units equipped with Vehicle Flamers (see p. 218, *TM*), Heavy Flamers (see p. 312), Fluid Guns (see p. 313) or Sprayers (see pp. 248-249, *TM*) may use the special fluid ammunitions described below. Unless otherwise noted (in brackets beside the ammo type's name), any given fluid ammunition type is considered to be available to all such weapon. All Fluid Gun or Flamer ammunition must be installed in full-ton lots. (When used for a Sprayer, however, Fluid Gun ammunition provides half the number of shots as it does for Fluid Guns.)

Units must designate their fluid ammunition types prior to the start of game play; if no specialty ammo is noted for a given Fluid Gun or Sprayer, it is presumed to be firing Water Ammo. If no specialty ammo is noted for a Flamer, it is presumed to be firing standard flamer ammo.

## COOLANT AMMO [FLAMERS/FLUID GUNS/SPRAYERS]

**Introduced:** Early spaceflight

A cryogenic, fast-cooling chemical mix less useful for firefighting than for rapidly reducing the surface temperature of superheated metals, coolant delivered by sprayers and fluid guns can be a huge help in a pitched battle.

### COOLANT AMMO [FLAMERS/FLUID GUNS/SPRAYERS]

**Rules Level:** Advanced

**Tech Base (Ratings):** Both (C/B-B-B)

**Game Rules:** If fired on a hex, structure or unit that has caught fire, coolant ammo douses all such fires not created by Inferno munitions (such as Inferno Fuel, Inferno Missiles, Inferno Mines and Inferno Artillery rounds) on a 2D6 roll of 4+. For fires caused by Inferno munitions, a roll of 12 is required to extinguish the flames.

Coolant ammo also reduces the heat level for any heat-tracking target by 3 points per hit (to a maximum of 9 cooling points per turn). Coolant fired at conventional infantry is treated as a 1-point direct-fire (ballistic) weapon when determining damage to the unit (see p. 216, *TW*). Heat-tracking units carrying coolant ammo will not set off the coolant from overheating, but coolant ammo that explodes from a critical hit reduces the heat level of such units by 3 points, in addition to the 2 points of internal damage from exploding Fluid Gun ammo.

## CORROSIVE AMMO [FLUID GUNS/SPRAYERS]

**Introduced:** Pre-spaceflight

Another chemical mixture developed for industrial applications first and foremost, fluid gun corrosive ammo is used to gradually dissolve hard debris, but can endanger military armor.

### CORROSIVE AMMO [FLUID GUNS/SPRAYERS]

**Rules Level:** Advanced

**Tech Base (Ratings):** Both (C/C-D-D)

**Game Rules:** On a successful attack against any target except conventional infantry, Corrosive Ammo delivers 1D6 damage points during the Weapon Attack Phase, and another 1D6 ÷ 2 points (rounded up) in the End Phase of the same turn. This damage is resolved in 1-point damage clusters. Against conventional infantry, corrosive ammo inflicts 1D6 burst-fire damage.

Heat-tracking units carrying corrosive ammo will not set off the chemicals through overheating, but corrosive ammo that explodes from a critical hit inflicts 1D6 damage points to the unit's internal structure when the ammo explodes, in addition to the 2 points of internal damage from exploding Fluid Gun ammo. In the End Phase of the following turn, the internal structure takes an additional 1D6 ÷ 2 points of damage (rounded up).

## FLAME-RETARDANT FOAM AMMO [FLUID GUNS/SPRAYERS]

**Introduced:** Pre-spaceflight

This fluid gun ammunition is a foaming liquid that effectively smothers and saturates a target area at the same time. Designed to counter not only

normal fires, but also electrical, chemical and even oil-based fires, flame-retardant foam proved ideal for anti-Inferno work, though expense kept it from becoming a battlefield standby.

### FLAME-RETARDANT FOAM AMMO [FLUID GUNS/SPRAYERS]

**Rules Level:** Advanced

**Tech Base (Ratings):** Both (B/B-B-B)

**Game Rules:** If fired on a hex, structure or unit that has caught fire, Flame-Retardant Foam douses all fires immediately, including those created by Inferno munitions (such as Inferno Missiles, Inferno Mines and Inferno Artillery rounds). In addition, any rolls to set on fire a hex or unit that has been struck by Flame-Retardant Foam receive a +4 target number modifier (starting from a base target number of zero for any weapons that would otherwise automatically set such targets ablaze).

Heat-tracking units carrying Flame-Retardant ammo will not set off the ammo from overheating, but Flame-Retardant ammo that explodes from a critical hit reduces the heat level of such units by 2 points, in addition to the 2 points of internal damage from exploding Fluid Gun ammo.

## INFERNO FUEL AMMO [FLAMERS/FLUID GUNS]

**Introduced:** 2400 (Terran Hegemony)

A variation on standard non-fusion flamer fuel, Inferno fuel uses the same adhesive-gel formula as found in Inferno SRMs, to deliver a more lingering

heat-effect damage to a target. As with Inferno SRMs, Inferno fuel is highly volatile—and even poses a significant threat to non-military vehicles that attempt to carry them.

INTRODUCTION

ADVANCED  
GROUND MOVEMENT

ADVANCED  
COMBAT

ADVANCED  
BUILDINGS

ADVANCED  
SUPPORT  
VEHICLES

GENERAL  
RULES

ADVANCED  
SUPPORT VEHICLE  
CONSTRUCTION

ADVANCED  
WEAPONS  
AND EQUIPMENT

INDEX

RECORD SHEETS

## INFERNO FUEL AMMO [FLAMERS/FLUID GUNS]



**Rules Level:** Advanced

**Tech Base (Ratings):** Both (D/D-E-D)

**Game Rules:** Flamers and Fluid Guns using Inferno Fuel deliver their attacks as normal, but with the following exceptions:

- Each hit from a standard Vehicle Flamer or a Fluid Gun using Inferno Fuel is treated as a hit from a single Inferno SRM missile (see pp. 141-142, *TW*). A hit by a Heavy Flamer using Inferno Fuel is treated as a hit by 2 Inferno SRM missiles (to the same hit location).
- Heat-tracking units carrying Inferno Fuel ammunition must check for heat-induced Inferno Fuel ammunition explosions as if carrying Inferno SRMs (see p. 141-142, *TW*).
- Support Vehicles lacking the Armored Chassis or Environmental Sealing modifications are particularly ill-suited for using Inferno Fuel. Any such units that suffer any form of external heat damage while using Inferno Fuel ammo (or which suffer a critical hit to a transport bay carrying Inferno Fuel) will suffer an Inferno Fuel ammunition explosion on a 2D6 roll of 10+.

## OIL SLICK AMMO [FLUID GUNS/SPRAYERS]

**Introduced:** Pre-spaceflight

"Oil slick" ammo actually consists of industrial-grade lubricants primarily intended for servicing extremely heavy machinery, but includes a flammable content that has led to its use as an incendiary aid as well. In the arenas of

Solaris, some MechWarriors have taken to using this fluid gun "ammunition" against open pavement in the hopes of encouraging their opponents to slip and fall in the tight arena confines. That latter use led to the common name for what is, in essence, another tool for heavy industry.

## OIL SLICK AMMO [FLUID GUNS/SPRAYERS]



**Rules Level:** Advanced

**Tech Base (Ratings):** Both (B/B-B-B)

**Game Rules:** Oil Slick Ammo inflicts no damage in a successful attack, but adds a -2 modifier to the target number for igniting a unit or hex that has been doused by a successful oil slick attack.

Furthermore, if applied (through a successful attack) to a clear hex, any ground units other than infantry, hovercraft or WIGE vehicles must make a Piloting Skill roll at a +1 target number modifier to avoid a skid when passing through the hex (see pp. 62-65, *TW*). This roll is made regardless of whether or not the unit is using Walking/Cruising MP or Running/Flanking MP. If an oil slick is applied to a paved or bridge hex, an additional +1 target number modifier applies to this roll.

Heat-tracking units carrying Oil Slick Ammo check for ammunition explosions from overheating as normal, but Oil Slick Ammo that explodes from a critical hit inflicts 1 point of damage per remaining shot, in addition to the 2 points of internal damage from exploding Fluid Gun ammo.

## PAINT/OBSCURANT AMMO [FLUID GUNS/SPRAYERS]

**Introduced:** Early spaceflight

Though some fluid guns fire simple paint with much the same effect, industrial- and military-grade obscurant ammunition actually describes any opaque chemical adhesives that not only can be used to provide color,

but also come laced with ferrous and magnetic additives designed to discourage and confuse sensors and other electronic signals. This has made "paint" ammo an unlikely weapon—at least in the arenas of Solaris—but a moderately effective one, at least.

## PAINT/OBSCURANT AMMO [FLUID GUNS/SPRAYERS]



**Rules Level:** Advanced

**Tech Base (Ratings):** Both (B/B-B-B)

**Game Rules:** Upon any successful attack against non-infantry units by a Fluid Gun using Paint/Obscurant Ammo, the Attacker must roll 2D6. On a result of 9+, the obscurants have affected the target's sensors, adding a +1 to-hit modifier for all weapon attacks by the target unit for the remainder of the scenario (unless washed off by a Fluid Gun using water). Additional hits can raise this modifier to a maximum of +3.

Against infantry, Paint/Obscurant Ammo has no effect.

Heat-tracking units carrying Paint/Obscurant Ammo will not set off the ammo from overheating, but Paint/Obscurant Ammo that explodes from a critical hit inflicts 1 point of damage per remaining shot, in addition to the 2 points of internal damage from exploding Fluid Gun ammo.

## WATER AMMO [FLAMERS/FLUID GUNS/SPRAYERS]

**Introduced:** Pre-spaceflight

Water ammo, as the name suggests, is simply a high-pressure water tank used to deliver water to a target hex. This is often used for power-washing purposes, firefighting or even riot control.

## WATER AMMO [FLAMERS/FLUID GUNS/SPRAYERS]

**Rules Level:** Advanced

**Tech Base (Ratings):** Both (A/A-A-A)

**Game Rules:** If fired on a hex, structure or unit that is burning, Water Ammo douses all such fires not created by Inferno munitions (including Inferno Fuel, Inferno Missiles, Inferno Mines and Inferno Artillery rounds) on a 2D6 roll result of 3+. For fires caused by Inferno munitions, Water Ammo extinguishes the flames only on a result of 12. Against conventional infantry, a successful hit from a Flamer, Fluid Gun, or Sprayer using Water Ammo inflicts  $1D6 \div 2$  (round up) damage points as a burst-fire weapon (but for purposes of determining casualties, such troopers should be considered knocked out, not killed).

Water Ammo also reduces the heat level for any heat-tracking target by 1 point per hit (to a maximum of 6 cooling points per turn), and can wash off Paint/Obscurant Ammo "damage" on a 2D6 result of 9+ after making a successful attack on a unit struck by paint/obscurant.

Water ammunition will not explode due to overheating effects on heat-tracking units, nor will it explode when the Water Ammo slot suffers a critical hit. Damage to a Water Ammo slot will not cause the affected location to "flood".

## GRENADE LAUNCHER MUNITIONS

The grenade launcher is a straightforward piece of equipment, but its munitions give it flexibility in battle. While adaptable for a great many situations, however, the one-shot capability of vehicular grenade launchers

means that the forces fielding them must carefully choose their ordnance in advance to maximize their potential.

## GRENADE LAUNCHER MUNITIONS

**Game Rules (General):** Only units equipped with Vehicular Grenade Launchers (VGLs; see p. 315) may use grenade launcher ammunition of any type. The ammunition each VGL unit mounts must be identified prior to the start of game play; if no specialty munitions are noted for a given VGL, it is presumed to be using fragmentation grenades.

## CHAFF GRENADES

**Introduced:** 3052 (Draconis Combine)

Inspired by the elaborate sensor-baffling techniques used on Wolcott during the Clan invasion, the Draconis Combine introduced chaff grenades as a mobile cover weapon concept in 3052. Chaff grenades release a cloud

of electromagnetic dust and high-intensity flares intended to confuse most electronic and thermal sensors, but their short battlefield duration led many warriors to forego these weapons in favor of electronics with more lasting potency, and weapons with more lethality.

## CHAFF GRENADES

**Rules Level:** Advanced

**Tech Base (Ratings):** Both (B/D-E-E)

**Game Rules:** Chaff Grenades produce ECM-like effects in the hexes they attack, interfering with the abilities of advanced sensors and other electronics passing through those hexes per an ECM Suite (see p. 134, TW). In addition, a Chaff Grenade cloud is treated as Light Smoke 2 levels high for any weapon attacks passing through the affected hexes (see p. 47). The ECM and smoke effects produced by Chaff Grenades last until the End Phase of the following turn.

## FRAGMENTATION GRENADES

**Introduced:** Pre-spaceflight

The standard round found in vehicular grenade launchers, fragmentation grenades are made for anti-infantry work, showering a target area with a cloud of shrapnel intended to maim as much as it kills.

## FRAGMENTATION GRENADES

**Rules Level:** Advanced

**Tech Base (Ratings):** Both (B/B-B-B)

**Game Rules:** Like all VGL attacks, Fragmentation Grenades automatically affect all units in their target hexes when fired. Against all units except conventional infantry and Support Vehicles with armor BAR values of 5 or more, Fragmentation Grenades inflict no damage. Against Support Vehicles with BAR values below 5, Fragmentation Grenades inflict damage equal to 5 points minus the unit's BAR (to a minimum of 0 points of damage), resolved as a single direct-fire ballistic attack. Against conventional infantry, Fragmentation Grenades deliver a 2D6 burst-fire attack.

INTRODUCTION

ADVANCED  
GROUND MOVEMENT

ADVANCED  
COMBAT

ADVANCED  
BUILDINGS

ADVANCED  
SUPPORT  
VEHICLES

GENERAL  
RULES

ADVANCED  
SUPPORT VEHICLE  
CONSTRUCTION

ADVANCED  
WEAPONS  
AND EQUIPMENT

INDEX

RECORD SHEETS

## INCENDIARY GRENADES

**Introduced:** Pre-spaceflight

Essentially miniature canisters of flammable gels similar to Inferno fuel, incendiary grenades are ideal for setting fires and using the resulting smokescreen for cover.



### INCENDIARY GRENADES



**Rules Level:** Advanced

**Tech Base (Ratings):** Both (B/B-B-B)

**Game Rules:** Incendiary Grenades ignite the hexes in their area of effect as though a single Inferno SRM had struck them (see p. 44). Units within such hexes suffer effects akin to taking a hit from a single Inferno SRM (see p. 141, *TW*).

## SMOKE GRENADES

**Introduced:** Pre-spaceflight

Developed simply to provide mobile cover or to mark a unit in distress, smoke grenades are an ancient concept that has retained its value in the modern battlefield.



### SMOKE GRENADES



**Rules Level:** Advanced

**Tech Base (Ratings):** Both (A/B-B-B)

**Game Rules:** When fired, Smoke Grenades produce Light Smoke in all of their target hexes (see p. 47). This smoke rises 2 levels above the underlying terrain, and lasts until the End Phase of the third turn after they are fired before dissipating.

## MINES

Mines have been a favored tool for static defenses since Terra's Middle Ages, but these explosive booby traps truly earned their place on the battlefield in the 1900s. Development of mine technology has since worked toward the dual goals of making them more effective against

hostile units while safer for operators. The recent explosion in minefield technologies has aimed at addressing the realities of the thirty-first century battlefield, enhancing the effectiveness of the mines themselves and their delivery systems.



### MINES



**Rules Level (General):** Advanced (All except EMP Mines); Experimental (EMP Mines)

**Available To (General):** Mines may be deployed by specialized minelayer infantry, units equipped with appropriate mine dispensers, or (in select cases) as a special ammunition type for certain weapon systems (including LRMs and Artillery).

**Game Rules (General):** Minefields, when deployed, can vary in damage based on the mine types and deployment methods used. Missile-deployed mines may vary their damage values based on the launcher type and size used, while dispenser-deployed mines receive a set "standard" damage value that reflects the dispenser's capacity.

Additional minefield game rules appear with each mine type outlined below.

## ACTIVE MINES (LAND)

**Introduced:** Early spaceflight

Though technically available for a millennium, active (jumping) mines have been largely under-used in favor of less expensive conventional mines. The coming of the Clans and the increasing numbers of jump-capable

infantry, battle armor, hovercraft, and WiGE vehicles have prompted many realms to reinvest in this more active form of static defense. The Capellan Confederation has led this revival in recent decades, debuting dispenser and LRM-launched variations for an ever-wider deployment of these devices.



### ACTIVE MINES (LAND)



**Rules Level:** Advanced

**Tech Base (Ratings):** Both (D/X-X-E)

**Game Rules:** See p. 209 for rules on Active Minefields. As with Standard Mines, unless cleared (see p. 210), Active Mines may detonate multiple times in a scenario.

**Mines:** For the purposes of unit construction, mines are treated as an ammunition type, rather than a specific item that can be mounted and fired. The weapons and equipment tables (see pp. 404–418) define which mines may be deployed as specialty munitions for which weapon types.

## COMMAND-DETONATED MINES (LAND/SEA)

**Introduced:** Pre-spaceflight

The first mines were command-detonated mines, typically set off by nearby soldiers armed with a simple fuse. Today's command-detonated mines, triggered mostly by wireless signals, can be detonated from orbit

if desired (though most commanders prefer to have troops in the field with line of sight to ensure that the proper targets are hit). The human-controlled aspect makes command-detonated mines one of the "safer" types in current use.

## COMMAND-DETONATED MINES (LAND/SEA)

**Rules Level:** Advanced

**Tech Base (Ratings):** Both (B/C-D-C)

**Game Rules:** See p. 209 for rules on Command-Detonated minefields. If the Command-Detonated Minefield is sea-based, it also inflicts half its normal damage (rounded up) against any unit(s) within 1 depth above or below their current depth when detonated (up to the surface of the water).

As with Standard Mines, unless cleared (see p. 210), Command-Detonated Mines may detonate multiple times in a scenario.

## ELECTROMAGNETIC PULSE (EMP) MINES (LAND)

**Introduced:** 2680 (Terran Hegemony [Vibrabomb]),  
3065 (Word of Blake [Command-Detonated])

**Extinct:** 2825 ([Vibrabomb])

**Reintroduced:** 3058 (Free Worlds League [Vibrabomb])

Originally developed by the Terran Hegemony exclusively for the Star League Defense Force, the Electromagnetic Pulse (EMP) Mine was a vibrabomb-based device that delivered a high-energy pulse capable of disabling a BattleMech without causing any actual damage. The sophisti-

cated technology to produce this pulse without a full-scale nuclear blast prevented the weapon from becoming too widespread, and the last major caches of these devices were expended soon after the First Succession War, but enough samples lingered to provide the Free Worlds League (and the Word of Blake) a means to revive the concept in the years leading up to the Jihad. Since then, various resistance groups have also obtained samples of this technology, but demand still far outstrips the production, preventing them from becoming a common sight.

## ELECTROMAGNETIC PULSE (EMP) MINES (LAND)

**Rules Level:** Experimental

**Tech Base (Ratings):** Both (E/F-X-F)

**Game Rules:** EMP Mines may not be deployed by launchers, but must instead be deployed by minelayer infantry or mine dispensers, or placed in predetermined hexes (see p. 207).

EMP mines are detonated using the same rules as described for their mine type. (See p. 209 for Command-Detonated mines, and p. 209 for Vibrabombs.) EMP mines affect all units in the mined hex upon detonation and create a 1-hex ECM "bubble" in the area of effect that lasts until the End Phase of the following turn after detonation, but deliver physical damage only to conventional infantry units (1D6 points, treated as Area-Effect damage, see p. 216, *TW*). Against all other units, the minefield's controlling player must roll 2D6 and consult the EMP Mine Effects Table Below (apply a +2 modifier to this roll if the affected unit is a drone, see p. 305). If any electronic systems not mounted upon an active unit (such as Remote Sensors, C<sup>3</sup> Remote Sensors, or Collapsible Command Modules, see pp. 357, 298 and 301, respectively) are inside an EMP mine's area of effect, these electronics are considered destroyed by the pulse.

EMP mines may make only one attack per scenario.

### EMP MINE EFFECTS TABLE

Target Unit*	No Effect (2D6 Roll)	Interference (2D6 Roll)	Shutdown (2D6 Roll)
BattleMech	2-6	7-8	9+
IndustrialMech	2-5	6-7	8+
ProtoMech	2-5	6-8	9+
Battle Armor†	2-5	6-7	8+
Combat Vehicles	2-5	6-7	8+
Support Vehicles	2-4	5-6	7+
Aerospace Fighter/Small Craft‡	2-6	7-8	9+
Conventional Fighters‡	2-5	6-7	8+

**Interference:** The unit suffers a +2 modifier for all weapon attacks and sensor operations for 1D6 turns, during which time all of its electronics are also affected as though operating within a hostile ECM field). The effects wear off in the End Phase of the final turn. \*Mechs, aerospace fighters, and small craft also generate 5 extra heat points per turn while affected.

**Shutdown:** Unit completely shuts down for 1D6 turns, powering up normally during the End Phase of the final turn. If the unit is a hovercraft or WIGE vehicle at ground level, the unit must make a successful Drive Skill roll with a modifier of +3 to avoid skidding (see p. 62, *TW*).

\*EMP Mines have no effect against Mobile Structures or units weighing more than 200 tons.

†For ease of play, all troopers in a battle armor unit are equally affected by the EMP Mine Effects.

‡Grounded units only; EMP Mines cannot target airborne units.

INTRODUCTION

ADVANCED  
GROUND MOVEMENT

ADVANCED  
COMBAT

ADVANCED  
BUILDINGS

ADVANCED  
SUPPORT  
VEHICLES

GENERAL  
RULES

ADVANCED  
SUPPORT VEHICLE  
CONSTRUCTION

ADVANCED  
WEAPONS  
AND EQUIPMENT

INDEX

RECORD SHEETS

## INFERNO MINES (LAND/SEA)

**Introduced:** 3055 (Capellan Confederation)

Though incendiary mines have existed for centuries, the Capellan Confederation and its Chaos March-based guerillas introduced the current incarnation—dubbed Inferno mines—shortly before Operation Guerrero.

### INFERNO MINES (LAND/SEA)

**Rules Level:** Advanced

**Tech Base (Ratings):** Both (C/X-X-D)

**Game Rules:** Inferno Mines use the rules for Standard (Conventional) Mines when making attacks (see pp. 208), but instead of inflicting normal damage, these mines deliver the equivalent effects of a single Inferno Missile (see p. 141, *TW*) for every 2 points of minefield strength.

Sea-type Inferno Mines may only be employed on the surface of a water feature; Inferno Mines are ineffective when submerged.

As with Standard (Conventional) Mines, unless cleared (see p. 208), Inferno Mines may detonate multiple times in a scenario.

## SPACE MINES (SPACE)

**Introduced:** Early spaceflight

Useful when space travel was limited or deployed around important locations, space mines fell into disuse for nearly a millennium. The re-

cent advent of screen launchers has brought space mines back into the modern battlefield.

### SPACE MINES (SPACE)

**Rules Level:** Advanced

**Tech Base (Ratings):** Both (C/E-F-E)

**Game Rules:** Space Mines are set up in dense fields, either by combat engineers prior to the battle, by Space Mine dispensers or by a screen launcher during battle. Mines can only be placed on a space hex, and any mines placed within 10 hexes of a space/atmosphere interface suffer gravity effects (moving 1 hex toward the planet per turn), eventually being destroyed if they enter the interface or atmosphere below.

Any unit entering a hex containing Space Mines (or present in the hex when one is deployed) must make a Control roll with a +3 modifier. An additional -2 modifier applies if the unit possesses an Active Probe or is in the hex at the turn the minefield is deployed. Craft that fail this Control roll suffer damage to the Nose (or, if advanced movement rules from *Strategic Operations* are used, to whichever facing entered the field first) equal to their Margin of Failure times a value based on the unit's size. This damage value (and the maximum amount of damage a Space minefield may inflict upon a passing unit) is shown in the Space Minefield Table below.

Once a Space minefield inflicts damage in this fashion, it loses a portion of its overall Attack Capacity (which starts at 6, reflecting the maximum number of attacks the minefield can make). This value, as with the base and maximum damage inflicted, also varies with the unit suffering the attack and is shown in the Space Minefield Table. Once reduced to an Attack Capacity of 0 (or less), a Space minefield is considered destroyed. A Space minefield inflicts its damage normally until it is reduced to or below an Attack Capacity of 0.

For example, a *Sholagar* aerospace fighter, needing an 8+ to avoid a Space minefield with an Attack Capacity of 3, rolls a 5; the *Sholagar* suffers 15 points of damage (its Margin of Failure of 3 [8 - 5 = 3] x 5 points [because it is an aerospace fighter] = 15), distributing the damage in groups of 5. The minefield, meanwhile, is reduced to an Attack Capacity of 2 (3 - 1 point for a fighter passing through the field). If a WarShip were to then pass through—also with a Control roll result of 8+ needed to avoid the field—and it rolled a 2, it would suffer 100 points of standard-scale damage (Margin of Failure 6 [8 - 2 = 6], damage of 20 per point of MoF [20 x 6 = 120, but the maximum damage per attack is 100]), and would reduce the field's Attack Capacity to -1 (2 - 3 points for a WarShip passing through the field = -1), rendering it ineffective.

### SPACE MINES TABLE

Craft Type	Damage Per Unit (per MoF)	Max. Damage Per Attack	Attack Capacity Reduction
Fighter/Small Craft/Satellite	5	20	1
DropShip	10	50	2
JumpShip/Space Station/WarShip	20	100	3

## STANDARD (CONVENTIONAL) MINES (LAND/SEA)

**Introduced:** Pre-spaceflight

Indiscriminate, standard mines explode when someone or something of significant mass comes into contact with them. Often seeded around key passages or installations, or deployed on the fly for "area denial," most

modern mines are built with chemicals that break down after a prescribed time, rendering them inert usually after six months to five years. This feature is designed to minimize civilian casualties once the battlefield has moved elsewhere.

## STANDARD (CONVENTIONAL) MINES (LAND/SEA)

**Rules Level:** Advanced

**Tech Base (Ratings):** Both (B/C-C-C)

**Game Rules:** See p. 208 for full rules on standard (or Conventional) minefields. Note that sea-based Standard minefields attack any unit at their depth (including hovercraft, hydrofoils and WiGEs, if the sea mines are on the water's surface).

Unless cleared (see p. 210), Standard minefields may detonate multiple times throughout a scenario.

## VIBRABOMB MINES (LAND)

**Introduced:** 2445 (Lyran Commonwealth)

Vibrabombs are specifically designed with 'Mechs in mind. Using seismic sensors, these minefields are programmed to target units of a specific weight, as measured by their seismic signature. But while they are excellent

for targeting a specific heavy unit—vibrabombs are ineffective against conventional infantry—they do not work so well against forces of mixed or unknown weights and sizes.

## VIBRABOMB MINES (LAND)

**Rules Level:** Advanced

**Tech Base (Ratings):** Both (C/E-E-D)

**Game Rules:** See p. 209 for rules on Vibrabomb minefields.

As with Standard Mines, unless cleared (see p. 210), Vibrabomb Mines may detonate multiple times in a scenario.

# MISSILE MUNITIONS

Among the most versatile weapons employed by modern armies, missiles can deploy all manner of innovative guidance systems and warheads. Moving beyond the recovered technologies of the Star League, both the

Inner Sphere and the Clans have continued to develop new missile munitions in ever-increasing varieties since the 3050s.

## MISSILE MUNITIONS

**Game Rules (General):** The following missile munitions are alternative reloads available only to specific launcher types. If a given weapon system does not identify its munitions type at the start of a scenario, presume the weapon is firing its most standard missile type (unspecified LRM munitions are considered to be standard LRMs; unspecified Artemis-equipped launchers use Artemis-capable standard missiles, and so forth).

For all 'Mech and vehicle units mounting appropriate launchers, specialized missile munitions may only be installed in full-ton lots. ProtoMech units permitted any applicable alternative missile type may install reloads on a per-missile basis, at twice the weight of their standard missile reload.

Missiles (other than Narc and iNarc warheads) that attack a target unit must roll on the appropriate column of the Cluster Hits Table. Missiles fired on a hex automatically hit the target hex with a full volley.

## ACID (AX) MISSILES [STANDARD SRMS/MMLS]

**R&D Start Date:** 3050 (Federated Commonwealth)

**Prototype Design and Production:** 3053 (Federated Commonwealth)

The AX missile was a NAIS response to the recovered ferro-fibrous armor types entering production (or under development) during the late 3040s and early 3050s. Loaded with industrial-strength acids and enzymes, AX SRMs promised additional damage against ferro-fibrous armor, but the missiles

fared poorly after rumors circulated that their liquid payload sloshed during flight, impairing their accuracy. In truth, the missiles' guidance equipment was sacrificed in favor of an enlarged warhead to deliver enough payload for a battlefield effect, as well as the secondary explosive charges necessary to scour the target's armor for maximum chemical saturation.

## ACID (AX) MISSILES [STANDARD SRMS/MMLS]

**Rules Level:** Experimental

**Tech Base (Ratings):** Inner Sphere (E/X-X-F)

**Game Rules:** AX SRM warheads function as standard SRMs with the following exceptions:

- AX SRMs suffer a -2 modifier when rolling on the Cluster Hits Table.
- AX SRMs inflict a base 3 points of damage per missile against units using any form of Ferro-Fibrous, Ferro-Lamellor, Laser-Reflective or Reactive armor, as well as any unit that has a BAR value of 5 or less. (This damage may be modified by special armor rules.) Against all other armor (and structure) types, AX SRMs inflict the standard 2 points of SRM damage. Conventional infantry multiply the damage inflicted by AX SRM attacks by 1.5 (rounding up).
- If excess damage from an AX warhead destroys the last of the armor in a given location, no damage carries over into the internal structure (but subsequent AX missile hits directly against internal structure will inflict normal SRM damage).
- AX SRMs are incompatible with Artemis, Narc or Streak technology.

INTRODUCTION

ADVANCED  
GROUND MOVEMENT

ADVANCED  
COMBAT

ADVANCED  
BUILDINGS

ADVANCED  
SUPPORT  
VEHICLES

GENERAL  
RULES

ADVANCED  
SUPPORT VEHICLE  
CONSTRUCTION

ADVANCED  
WEAPONS  
AND EQUIPMENT

INDEX

RECORD SHEETS

## ANTI-RADIATION (ARAD) MISSILES [STANDARD SRMS/STANDARD LRMS/MMLS]

**R&D Start Date:** 3055 (Clan Smoke Jaguar), 3065 (Free Worlds League)

**Prototype Design and Production:** 3057 (Clan Smoke Jaguar),  
3066 (Free Worlds League)

Avoiding the pitfall of the short-lived Listen-Kill missiles that were swiftly

rendered obsolete in the 3040s, these prototype missiles promise to retain their normal range and damage profiles while homing in on active electronic systems with greater accuracy—effectively turning electronic warfare systems against their users.

### ANTI-RADIATION (ARAD) MISSILES

**Rules Level:** Experimental

**Tech Base (Ratings):** Both (E/X-X-E)

**Game Rules:** ARAD Missiles use the same rules as Narc-equipped standard missile types for their launcher and size, with the following exceptions:

- ARAD Missiles ignore the effects of hostile ECM when targeting a unit tagged by a friendly Narc pod.
- ARAD Missiles are more accurate against any unit that actively emits electronic signals, and receive a –1 to-hit modifier and a +1 Cluster Hits Table roll modifier if the target is using at least one of the following systems: Active Probes (of any kind), Artemis fire-control systems, the Blue Shield system, C<sup>3</sup> systems (of any kind), communications equipment (1 ton or more), or ECM suites (of any kind). These modifiers are not cumulative, even if the target unit is using multiple electronic warfare systems.
- Against any target *not* using the above-listed electronic warfare systems, ARAD Missiles suffer a +2 to-hit modifier and a –2 Cluster Hits Table roll modifier (to a minimum result of 2).
- ARAD Missiles are incompatible with Artemis or Streak systems.

## BOLA NARC PODS (NARC LAUNCHER)

**R&D Start Date:** 3052 (Capellan Confederation)

**Prototype Design and Production:** 3056 (Capellan Confederation)

Intended as a 'Mech-snaring alternative munition, the bola pod was developed by the Capellan Confederation and tested during the Capellan-Free Worlds invasion of the Federated Commonwealth in 3057. A variation on

the explosive Narc pod, charges blast the bola pod apart in flight, unraveling large, industrial-grade chains that, aimed properly, can snag the limbs of a target BattleMech. The weapon's inaccuracy and lack of effectiveness against other units, such as vehicles and fighters, led the Confederation to abandon plans for widespread production.

### BOLA NARC PODS (NARC LAUNCHER)

**Rules Level:** Experimental

**Tech Base (Ratings):** Inner Sphere (D/X-X-E)

**Game Rules:** Works only with standard Narc launchers and follows all the same rules as standard Narc pods, with the following exceptions:

- Bola Narc pods suffer a +1 to-hit modifier.
- Bola Narc pods inflict no damage upon a successful hit, and have no effect in combat against any unit other than 'Mechs, ProtoMechs and VTOL Vehicles, for which a hit location roll is needed upon a successful attack. Bola pods that hit a 'Mech in the head or torso locations have no game play effect, nor do Bola pods that hit a ProtoMech in the head, torso or main gun locations, or Bola pods that hit a VTOL in any location other than the rotor.
- A Bola Narc Pod that hits a 'Mech in the legs forces the unit to make a Piloting Skill roll (with an additional +1 target number modifier) at the end of the Weapon Attack Phase to avoid falling, and the 'Mech cannot deliver a kick attack during that turn. In addition, the 'Mech suffers a –1 MP modifier in the following Movement Phase to break free of the chains.
- ProtoMechs hit in the legs by a Bola pod suffer a –2 MP Walk modifier (and cannot jump) in the following Movement Phase as they break free of the Bola's chains.
- VTOLs hit in the rotor treat the result as a Rotor Destroyed critical hit, regardless of any armor or structure left on the unit's rotors.
- Bola Narc Pods that hit a 'Mech or ProtoMech in an arm impose a +1 to-hit modifier for all weapon and physical attacks made using the affected arm until the End Phase of the following turn.

## FOLLOW-THE-LEADER (FTL) MISSILES [STANDARD LRMS/MMLS]

**R&D Start Date:** 3049 (Federated Commonwealth)

**Prototype Design and Production:** 3053 (Federated Commonwealth)

Based on experimental Star League-era missiles, FTL missiles improve missile grouping, increasing the damage done to specific areas by a net-

worked guidance system that locks onto the first missile to hit the intended target. Because the missiles sometimes followed the wrong warhead, the system never saw mass production.

### FOLLOW-THE-LEADER (FTL) MISSILES [STANDARD LRMS/MMLS]

**Rules Level:** Experimental

**Tech Base (Ratings):** Both (E/F-X-E)

**Game Rules:** Follow-the-Leader (FTL) Missiles use the same rules as standard LRMs, with the following exceptions:

- FTL Missiles suffer a +2 to-hit modifier (reflecting the missiles' occasional tendency to follow the wrong warhead).
- Upon a successful hit, FTL Missiles receive a +1 roll modifier on the Cluster Hits Table, but rather than resolving these missile hits in groups of 5, all FTL Missiles that hit the target will hit the same location.
- FTL Missiles are incompatible with Artemis, Narc or Streak systems.

## HARPOON MISSILES [STANDARD SRMS]

**Introduced:** 2400 (Lyran Commonwealth)

A maritime hunter's weapon not designed for the battlefield, the SRM adaptation of the harpoon—introduced in 2400 by Lyran big game huntsmen—is the heaviest form of its kind. Little more than a kinetic, piercing head and a reinforced, detachable cable, the SRM-launched harpoon can penetrate the

hide of most any marine animal known in the Inner Sphere, and tow the hapless (and—hopefully—mercifully dead) creature into the vessel. While they can be quite effective against unarmored infantry as well, battlefield armor is effectively immune to the harpoon SRM, and most vehicles or 'Mechs would make quick work of the tow cable even if successfully speared.

## HARPOON MISSILES [STANDARD SRMS]

**Rules Level:** Advanced

**Tech Base (Ratings):** Both (C/C-C-C)

**Game Rules:** Harpoon Missiles use the same rules as standard SRMs with the following exceptions:

- Harpoons inflict no damage to (and thus do not penetrate) any target with a BAR value of 5 or more (this includes all types of BattleMech, Combat Vehicle and fighter armor). Against units with a BAR value of 4 or less, each Harpoon Missile inflicts 1 point of damage and “hooks” such units (but any unit with a functioning engine and motive systems can break the harpoon lines by spending 1 MP during the following Movement Phase).
- Harpoons cannot be used on the Space Map or in low-altitude combat by aerospace units (including Airships, Fixed-Wing and Satellite Support Vehicles).
- If the target of a successful Harpoon attack that delivers damage does not break the line, and the target weighs less than half the weight of the firing unit, the firing unit can “reel in” the target at a rate of 1 hex per turn during subsequent Movement Phases. A unit reeling in a harpooned target in this fashion may not move or take any other action. Once the target is fully reeled in (dragged into the firing unit's hex), the target becomes external cargo subject to the Cargo Carriers rules (see p. 261, *TW*). If the harpooned target weighs half as much as the firing unit (or more), it cannot be reeled in.
- The harpoon-firing unit may not move while attached to a harpooned target that has not been reeled in, but may make attacks and/or disengage its harpoon lines during any subsequent Weapon Attack Phase.
- A Harpoon Missile launcher may not be fired again until a harpooned target has been reeled in or the harpoon lines have been disengaged in a previous turn.
- Harpoon Missiles receive no benefit from Artemis, Narc or Streak systems.
- Though they lack explosive warheads, the propellant used in Harpoon Missiles remains highly volatile; Harpoon Missiles explode for 1 point of damage per missile in the event of a critical hit or heat-induced explosion.

## HEAT-SEEKING (HS) MISSILES [STANDARD LRMS/STANDARD SRMS/MMLS]

**Introduced:** 2340 (Terran Hegemony)

Though the technology dates back to air-to-air combat on pre-spaceflight Terra, heat-seeking guidance systems for LRMs and SRMs did not develop until a few decades after the debut of the launchers themselves. The sensors used to enhance their accuracy against high-heat targets while retaining their range and damage profiles, however, necessitated the removal of

other standard electronic sensors. As a result, these missiles are noticeably less accurate against targets that are not radiating a significant amount of heat. For this reason—and the fact that they are easily confused by open fires, such as those set by flamers and Inferno rounds—heat-seeking missiles are far less common than standard missile munitions.

## HEAT-SEEKING (HS) MISSILES [STANDARD LRMS/STANDARD SRMS/MMLS]

**Rules Level:** Advanced

**Tech Base (Ratings):** Both (C/E-E-E)

**Game Rules:** Heat-Seeking Missiles use the same rules as standard missile types for their launcher and size, with the following exceptions:

- Against heat-tracking units that have overheated, Heat-Seeking Missiles receive a to-hit modifier equal to the heat-induced MP modifier for the target. (For example, if a target BattleMech has overheated by 12 points—producing a -2 MP movement modifier—the missiles receive a -2 to-hit modifier.) An additional modifier of -2 applies if the target is currently on fire (see p. 43), or if the target is a Fighter, Small Craft, DropShip, or WarShip and the line of attack passes through its aft hexside.
- Against non-heat tracking units or units that have not overheated, Heat-Seeking Missiles receive a +1 to-hit modifier.
- If a flight of Heat-Seeking Missiles is fired into or through a hex that has been set on fire (see p. 43), a +2 to-hit modifier applies to the attack as well.
- Heat-Seeking Missiles are incompatible with Artemis, Narc or Streak systems.

## INCENDIARY LRMS (STANDARD LRMS/MMLS)

**Introduced:** 2341 (Terran Hegemony)

A variation on conventional LRM loads largely intended for multi-purpose use, incendiary LRM munitions mix fast-burning fuel-filled warheads with conventional missiles in every flight, resulting in volleys that retain their offensive potential, but also gain the ability to ignite structures and terrain

in a pinch. The dangers of ammo cook-off and the practice of using such weapons for “scorched earth” tactics led to their eventual abandonment in the later Succession Wars, but in the 3050s, munitions plants in the Free Worlds League initiated the first widescale production of incendiary LRMs for today's generation.

INTRODUCTION

ADVANCED  
GROUND MOVEMENT

ADVANCED  
COMBAT

ADVANCED  
BUILDINGS

ADVANCED  
SUPPORT  
VEHICLES

GENERAL  
RULES

ADVANCED  
SUPPORT VEHICLE  
CONSTRUCTION

ADVANCED  
WEAPONS  
AND EQUIPMENT

INDEX

RECORD SHEETS

## INCENDIARY LRMS (STANDARD LRMS/MMLS)

**Rules Level:** Advanced

**Tech Base (Ratings):** Inner Sphere (C/E-X-E), Clan (C/X-E-E)

**Game Rules:** Incendiary LRMs use the same rules as standard LRMs for their launcher and size, with the following exceptions:

- Incendiary LRMs are combined with other LRM munition types at a rate of 1 missile for every 5. Each flight of LRMs using Incendiary rounds will thus function per its normal game rules as though fired by a launcher 20 percent “smaller” (rounded up). (For instance, an Artemis IV-enhanced LRM 20 will attack a unit as if it were an Artemis-enhanced LRM 16 [ $20 - (20 \times .20) = 20 - (4) = 16$ ].)
- When fired at terrain or structures, Incendiary LRMs receive a +4 modifier to all rolls for starting fires (see p. 43). Incendiary LRMs may not set other units on fire or directly raise a target’s heat level, however (unlike Infernos, the chemicals used in Incendiary LRMs do not adhere well to armor).
- Against infantry units (conventional and battle armored), Incendiary LRMs add +1 damage to their attack for every 5 missiles in the volley.
- Incendiary LRMs check for heat-induced ammunition explosions as Inferno Missiles (see p. 141, *TW*).

## MAGNETIC PULSE (MP) MISSILES [STANDARD LRMS/STANDARD SRMS/MMLS]

**R&D Start Date:** 3050 (Free Worlds League)

**Prototype Design and Production:** 3055 (Free Worlds League)

**Introduced:** 3057 (Free Worlds League, Word of Blake)

**Extinct:** 3065

Magnetic pulse (MP) missiles were designed to overload modern battlefield electronics suites, but when House Marik designers first tested them, they discovered the warheads also weakened the engine shielding strength of fusion-powered targets (such as BattleMechs). These effects convinced the Captain-General to encourage further research on these weapons, which led to the present missile designs now being fielded-tested (sporadically) by the League and their Word of Blake occupiers.

Early reports of MP weapons proved to be exaggerated. Nevertheless, as rumors of an ultimate “Mech-stunner” weapon circulated in the 3050s, fusion engine manufacturers across the Inner Sphere responded with updated engine containment software designed to adjust to sudden external influences from magnetic-pulse missile volleys. As a result, while the MP missiles’ pulse still produces a brief “heat spike” in fusion engines, this is actually a side effect of strengthened containment fields that never exceed a certain limit. This development has left MP missiles mostly limited to their original role of anti-EW work, and hampered their ability to compete with more effective systems that hit the market at the same time, such as ComStar’s less-costly “Haywire” iNarc pods. As a result, MP missiles were discontinued shortly before the Jihad.

## MAGNETIC PULSE (MP) MISSILES

**Rules Level:** Experimental

**Tech Base (Ratings):** Inner Sphere (E/X-X-F)

**Game Rules:** Magnetic-Pulse (MP) Missiles use the same rules as standard missile types for their launcher and size, with the following exceptions:

- MP Missiles inflict no damage upon a successful attack. Instead, they impose a +1 to-hit modifier on all of the target unit’s weapon attacks starting with the end of the Weapon Attack Phase and lasting until the End Phase of the turn following the attack (additional hits by MP Missiles do not extend this effect, nor do they increase the modifier). MP Missiles have no effect against conventional infantry.
- Against any heat-tracking unit powered by a fusion engine, MP Missiles increase the target’s heat by +1 for every 5 LRM warheads (or 3 SRM warheads) that hit the target (rounded down). This heat spike affects the unit only for the turn in which the missiles hit.
- MP Missiles are incompatible with Artemis, Narc or Streak systems.

## MINE CLEARANCE MISSILES (STANDARD LRMS/STANDARD SRMS/MMLS)

**Introduced:** 3069 (Federated Suns)

To combat the decades-long explosion in enhanced minefield warfare perfected by the Capellan Confederation and its Chaos March insurgents, the Federated Suns began experimenting with a specialized enhancement for SRM and LRM launchers specifically tailored to anti-mine work. Designed

to deliver greater concussive force on ground impact, while showering the area with miniature explosives, the so-called mine clearance charges proved extremely effective against minefields, while also acting as a potent anti-infantry munition.

## MINE CLEARANCE MISSILES (STANDARD LRMS/STANDARD SRMS/MMLS)

**Rules Level:** Advanced

**Tech Base (Ratings):** Inner Sphere (C/X-X-E)

**Game Rules:** Mine Clearance (MC) Missiles use the same rules as standard missile types for their launcher and size, with the following exceptions:

- Mine Clearance Missiles can only be used to target hexes, not units. However, any units occupying the same hex hit by a Mine Clearance Missile strike suffer damage as if from an area-effect weapon strike equal to an equivalent missile volley at one quarter of the rated size, rounded down (for example, a volley of MC Missiles fired by an LRM-20 will inflict damage equal to a 5-point area-effect weapon, while a volley of MC Missiles from an SRM-6 will inflict damage equal to 1 SRM [ $6 \div 4 = 1.5$ , round down to 1], or 2 points). See p. 113, *TW*, for rules on area-effect weapons.
- Mine Clearance rounds reduce the density of any minefield type by a value equal to the MC volley’s rated damage, to a minimum of 0. If more than one minefield is present in the target hex, all fields are affected equally. (For example, an LRM-15 firing MC munitions will reduce a 20-point density minefield to 5 points.)
- Mine Clearance Missiles are incompatible with Artemis, Narc or Streak systems.

## SMOKE MISSILES (STANDARD LRMS/STANDARD SRMS/MMLS)

**Introduced:** 2333 (Terran Hegemony)

Like smoke artillery rounds, smoke LRMs and SRMs represent an ancient technology adapted to LRM and SRM use soon after the debut of the

launchers themselves. Through the centuries, however, these missiles have seen little use compared to smoke artillery, mainly because battlefield commanders prefer to keep their missile racks lethal.

### SMOKE MISSILES (STANDARD LRMS/STANDARD SRMS/MMLS)

**Rules Level:** Advanced

**Tech Base (Ratings):** Both (C/D-D-D)

**Game Rules:** Smoke Missiles use the same rules as standard missile types for their launcher and size, with the following exceptions:

- Smoke Missiles may only target hexes, not other battlefield units, and will not deliver damage to any units in the target hex.
- Smoke Missiles fill a target area with a column of smoke 2 levels high (see p. 47).
- This smoke varies in density and size with the damage capacity of the launcher used. For every 10 points of damage a Smoke Missile would deliver as a standard missile volley (rounded up), the radius of the smoke-filled area increases by 1 hex (so an LRM-5, with its 5 points of damage, would fill only 1 hex [Radius =  $5 \div 10 = 0.5$ , round up to 1], while an SRM-6, with 12 points of damage as a standard munition, would fill the target hex and each adjacent hex [Radius =  $12 \div 10 = 1.2$ , round up to 2]). This smoke is treated as Light Smoke if the weapon delivers 5 points or less in damage to the target hex. Otherwise, it is treated as Heavy Smoke.
- Smoke generated by Smoke LRMs will linger for a number of turns equal to the half the rack size of the launcher used (rounded down) before dissipating in the End Phase of the final turn. For example, an LRM-15 Smoke Missile volley creates smoke for 7 turns ( $15 \div 2 = 7.5$ , round down to 7) after the volley was fired. Smoke generated by Smoke SRMs will linger for a length of time equal to the size of the rack used, so an SRM-6 firing smoke rounds will create smoke for 6 turns before dissipating.
- Smoke Missiles are incompatible with Artemis, Narc or Streak systems.

## SWARM/SWARM-I LRMS (STANDARD LRMS/MMLS)

**Introduced:** 2621 (Terran Hegemony [Swarm LRMs]),

3057 (Free Worlds League [Swarm-I])

**Extinct:** 2833 (Inner Sphere [Swarm LRMs])

**Recovered:** 3053 (Federated Commonwealth [Swarm LRMs])

Using more sophisticated (and expensive) guidance systems than standard LRMs, Swarm LRMs were a Star League weapon design used to impressive effect on tightly grouped formations. Rather than simply continuing on or plunging to the ground after missing their targets, Swarm LRMs home in on any other target in the immediate vicinity and may swerve to hit them if fuel and mobility

allow. While dangerous to use when allied forces are in close quarters, the use of Swarm LRMs forced many hostile formations to break up and spread out, rather than risk being caught in a devastating Swarm saturation attack.

After the lost technology was re-introduced by FedCom producers in the wake of the Clan invasion, Free Worlds League designers immediately went to work on a modified version, the Improved Swarm (Swarm-I). Similar in many respects to the standard Swarm, Swarm-I's incorporate a rudimentary friend-or-foe recognition system that allows these missiles to ignore friendly forces and focus on the enemy.

### SWARM/SWARM-I LRMS (STANDARD LRMS/MMLS)

**Rules Level:** Advanced

**Tech Base (Ratings):** Both (E/E-X-D [Swarm]), Inner Sphere (E/X-X-D [Swarm-I])

**Game Rules:** Swarm and Swarm-I Missiles use the same rules as standard LRM types for their launcher and size, with the following exceptions:

- When resolving a successful Swarm/Swarm-I LRM attack against a target, note the number of missiles in the flight that fail to hit their target based on the Cluster Hits Table. Any remaining missiles in the flight will attempt to attack a secondary target from among the nearest units (friendly or enemy) in the same hex or in any adjacent hex. (For example, if only 12 missiles from an LRM-20 attack using Swarm Missiles successfully hit their target, 8 missiles survive to attack nearby units [ $20 - 12 = 8$ ]).
- If the initial Swarm/Swarm-I attack missed its target, but possible secondary targets (friendly or enemy) lie in the target's hex or any adjacent hexes, the missiles attack them as a secondary target.
- Swarm and Swarm-I Missiles resolve secondary attacks starting from the nearest unit (beginning with any units in the target's hex and moving outward), using the modifiers from the original attack for range, Attacker movement, Attacker conditions and weather conditions, but replace the original target's movement and terrain modifiers with those of the secondary target. If multiple secondary targets lie within the same distance, the secondary target is chosen at random. If the attack succeeds, use the Cluster Hits column based on the surviving missiles (in the case of the above example, this would mean the Attacker rolls on the 8 column for Cluster Hits).
- Swarm-I Missiles apply an additional +2 modifier for attacks against friendly units unless said units are operating within a hostile ECM field or have suffered a critical hit to their sensors.
- Swarm-I Missiles operating within a hostile ECM field function as standard Swarm LRMs, while standard Swarm LRMs attacking a target within a hostile ECM field function as standard LRMs.
- If any missiles remain from a Swarm/Swarm-I flight that hits a secondary target as described above, they may carry on to attack another secondary target as though the last target hit was their primary. If no other secondary targets exist within range of the last target (except for those already "attacked" once by a Swarm flight), the attack is completed (and any remaining missiles have missed). Neither the original primary target nor any secondary targets may be attacked more than once by any Swarm or Swarm-I flight.
- Swarm and Swarm-I LRMs are incompatible with Artemis, Narc or Streak systems.
- Anti-Missile Systems function normally against Swarm and Swarm-I missiles.

INTRODUCTION

ADVANCED  
GROUND MOVEMENT

ADVANCED  
COMBAT

ADVANCED  
BUILDINGS

ADVANCED  
SUPPORT  
VEHICLES

GENERAL  
RULES

ADVANCED  
SUPPORT VEHICLE  
CONSTRUCTION

ADVANCED  
WEAPONS  
AND EQUIPMENT

INDEX

RECORD SHEETS

## TANDEM-CHARGE (TC) MISSILES [STANDARD SRMS/MMLS]

**R&D Start Date:** 2753 (Terran Hegemony)

**Prototype Design and Production:** 2757 (Terran Hegemony)

Tandem-charge (TC) SRMs are specially designed warheads that produce an armor-penetrating effect through the use of a two-stage warhead. The first stage, a shaped-charge explosive, weakens modern armor enough so that the second-stage warhead can reach internal components more easily. Though the Star League never managed to put these weapons into

production, enough examples survived in caches that they enabled Fed-Com researchers to resume work on their development in the early 3050s. Difficulties with the development team and funding cuts slowed down production of these armor-penetrating munitions, which unfortunately also doubled the weight of a standard SRM, reducing reload capacities, and proved incompatible with smaller LRM missile types.

## TANDEM-CHARGE (TC) MISSILES [STANDARD SRMS/MMLS]

**Rules Level:** Experimental

**Tech Base (Ratings):** Inner Sphere (E/X-X-E)

**Game Rules:** Tandem-Charge (TC) Missiles use the same rules as standard SRMs with the following exceptions:

- Upon a successful hit, each TC warhead that strikes armor inflicts damage as a normal SRM round, but also rolls once on the Determining Critical Hits Table. If the warhead struck armor (but not internal structure), apply a -2 modifier to this roll (an additional +2 applies if the target is a Support Vehicle or IndustrialMech with an armor BAR of less than 10). Neither modifier applies if a TC warhead strikes internal structure directly.
- Against conventional infantry, TC missiles are treated as if they inflict half the base Damage Value of an equivalent flight of SRMs (determined before applying any modifiers for heavy weapons fired against conventional infantry, per pp. 216-217, *TW*). Against battle armor, the attacker rolls 2D6 for each TC missile that hits a trooper, eliminating the trooper on a result of 10+.
- Against aerospace units, TC missiles function as standard SRMs.
- In the event of an ammunition explosion, TC warheads explode for 3 points of damage per missile; for example, a single shot from an SRM-6 using TC missiles would explode for 18 points of damage.
- Tandem-Charge SRMs are incompatible with Artemis, Narc or Streak systems.

## TEAR GAS SRMS (STANDARD SRMS/MMLS)

**Introduced:** 2375 (Terran Hegemony)

Another adaptation of proven technology, tear gas SRMs are primarily used for non-lethal crowd control, delivering canisters of irritant gasses

into unruly crowds. Though most battlefield troops come prepared for the eventuality of chemical weapons, many can still be caught off-guard by their use.

## TEAR GAS SRMS (STANDARD SRMS/MMLS)

**Rules Level:** Advanced

**Tech Base (Ratings):** Both (C/B-B-B)

**Game Rules:** Tear Gas SRMs use the same rules as standard SRM missiles with the following exceptions:

- Tear Gas SRMs may only target hexes, not other battlefield units.
- Tear Gas units fill a target area with a column of Light Smoke 1 level high. This gas lasts for 15 turns and drifts in accordance with the normal Smoke rules (see p. 47).
- Conventional infantry and unsealed battle armor without air supply or filters (which must be declared prior to the start of the scenario) suffer damage equal to a successful attack by a standard SRM volley of equivalent size to the Tear Gas launcher if they are in the hex the gas affects.
- Vehicles that do not incorporate environmental sealing modifications suffer no damage from the gas, but must roll 2D6 when entering or staying in a hex full of tear gas. On a result of 8+, the unit (or the affected hex of the unit, in the event of multi-hex vehicles) suffers a Crew Stunned result. If the crew is already suffering from such an effect, treat the result as a Crew Killed result instead.
- All damage to infantry and vehicle crews done by Tear Gas SRMs is temporary, and will wear off at the End Phase of the 15th turn after the attack. Before then, however, any units successfully struck by tear gas may not use MP.
- Tear Gas SRMs are incompatible with Artemis, Narc or Streak systems.

## THUNDER LRMS (STANDARD LRMS/MMLS)

**Introduced:** 2620 (Terran Hegemony [Thunder]), 3056 (Capellan Confederation [Inferno]), 3057 (Capellan Confederation [Augmented, Vibrabomb]), 3058 (Capellan Confederation [Active])

**Extinct:** 2840 (Inner Sphere)

**Recovered:** 3052 (Federated Commonwealth)

Much like FASCAM, Thunder LRMs are used to dispense mines on the battlefield. Originally developed by the Terran Hegemony to scatter conventional minefields, Thunder LRMs were lost for most of the Succession Wars, only to be recovered soon after the Clan invasion. The 3050s then saw an explosion of alternative minefield types deployed in this method—all introduced by the Capellan Confederation.

## THUNDER LRMS (STANDARD LRMS/MMLS)

**Rules Level:** Advanced

**Tech Base (Ratings):** Both (E/D-X-D [Thunder]), Inner Sphere (E/X-X-D [Inferno]), Inner Sphere (E-X-X-E [Active, Augmented, Vibrabomb])

**Game Rules:** Thunder LRMs (and their variants: Thunder-Active LRMs, Thunder-Augmented LRMs, Thunder-Inferno LRMs, and Thunder-Vibrabomb LRMs) use the same rules as standard LRM missiles, with the following exceptions:

- Thunder LRMs may only target hexes, not other battlefield units.
- A successful attack on a target hex deploys a minefield with a density equal to the strength of the launcher delivering it. Multiple (or overlapping) minefields may be laid in the same hex for additional damage, but the total density of all mines in a hex delivered by Thunder LRMs may not exceed 20 points. The one exception to this rule is if a weapon-delivered minefield is laid in the same hex as a minefield placed prior to the start of play, in which case the maximum density of the hex cannot exceed 30 points; i.e. a pre-designated minefield of 15 points is hit by a 20 point weapon-delivered minefield, in which case it would be a 30 point minefield (see p. 207).
- Thunder-Augmented LRMs deliver minefields that scatter farther out than standard, and so deploy a minefield equal to half the missile flight's strength (rounded up) to the target hex and all adjacent hexes.
- Units within a hex when it is struck by a Thunder LRM flight may exit the hex without setting off the minefields these missiles lay, but all other units entering or passing through a mined hex follow the standard rules for the appropriate minefield (see p. 207).
- Once deployed, minefields delivered by any appropriate weapon system function in accordance with their standard game rules (see pp. 208–209; Standard Thunder mines and Thunder-Augmented mines use the standard (conventional) minefield rules; Thunder-Active mines use the active minefield rules; Thunder-Vibrabomb mines use the vibrabomb minefield rules).
- Thunder LRMs are incompatible with Artemis, Narc or Streak systems.

## 'MECH MORTAR AMMUNITION

The lack of variety in 'Mech mortar munitions compared to missiles may be better attributed to this weapon system's relatively low proliferation than to its lack of technological sophistication. But even if these weapons

are outclassed by the more versatile LRM system, some variety exists in their ammo selections that offers tactical options unavailable to comparable missile systems.

## 'MECH MORTAR AMMUNITION

**Rules Level (General):** Advanced

**Game Rules (General):** 'Mech Mortars (see p. 324) may use a variety of ammunition types. If a unit with a 'Mech Mortar does not specify its ammo type, use the rules for Armor-Piercing (Shaped-Charge) ammo. Mortars fired on a unit, rather than a hex, use the appropriate Cluster Hits Table to resolve their effects. Mortars fired on a hex, rather than the unit within, deliver the effects of a full volley and do not need to roll on the Cluster Hits Table.

## AIRBURST MORTARS

**Introduced:** 2544 (Terran Hegemony)

In essence, airburst mortars are a special, heavier version of the anti-personnel mortar with a proximity fuse designed to set off the shells at higher

than normal altitude. Intended to flush out forces using trenches and field works for cover, these shells saturate an area with hardened shrapnel that inflicts equal damage on infantry and armored targets alike.

## AIRBURST MORTARS

**Rules Level:** Advanced

**Tech Base (Ratings):** Both (C/B-D-C)

**Game Rules:** Airburst Mortars are fired at a hex, rather than at a target unit. Airburst Mortars inflict 1 damage point per shell to all targets in the hex, and delivers its damage in 1-point clusters (conventional infantry treat Airburst Mortars as a burst-fire weapon that delivers 1D6 damage per shell). Only units inside buildings avoid this damage (though the building itself suffers damage to its CF). Each shell of Airburst Mortar ammunition inflicts 1 point of damage in an ammunition explosion (multiplied as normal by the mortar rack's size and the total number of unfired rounds).

## ANTI-PERSONNEL (AP) MORTARS

**Introduced:** 2531 (Terran Hegemony)

A common round used in 'Mech mortars when faced with the prospect of heavy infantry activity, anti-personnel mortars use softer metals and ceramics that create a cloud of deadly shrapnel when the shells detonate at

(or close to) ground level. Though less popular than shaped-charge mortars due to their ineffectiveness against armored targets, anti-personnel mortars remain a tried and true munition.

INTRODUCTION

ADVANCED  
GROUND MOVEMENT

ADVANCED  
COMBAT

ADVANCED  
BUILDINGS

ADVANCED  
SUPPORT  
VEHICLES

GENERAL  
RULES

ADVANCED  
SUPPORT VEHICLE  
CONSTRUCTION

ADVANCED  
WEAPONS  
AND EQUIPMENT

INDEX

RECORD SHEETS

## ANTI-PERSONNEL (AP) MORTARS



**Rules Level:** Advanced

**Tech Base (Ratings):** Both (B/B-B-B)

**Game Rules:** Anti-Personnel (AP) Mortars are fired at a hex, rather than at a target unit. Each shell in an AP Mortar flight delivers  $1D6 \div 2$  burst damage points (rounded up) to conventional infantry units (for example, a full flight of 8 AP 'Mech Mortars delivers  $8D6 \div 2$  damage to a conventional infantry platoon). Against all other units, AP 'Mech Mortars inflict 1 damage point per shell, applied in 1-point groups. Each shell of Anti-Personnel Mortar ammunition inflicts 2 points of damage in an ammunition explosion (multiplied as normal by the mortar rack's size and the total number of unfired rounds).

## ARMOR PIERCING (SHAPED-CHARGE) MORTARS

**Introduced:** 2531 (Terran Hegemony)

The standard round used in most 'Mech mortars, armor-piercing mortars use shaped charges to penetrate combat armor more effectively. However,

because they throw out less shrapnel, armor-piercing mortars are a poor choice against standard infantry.

## ARMOR PIERCING (SHAPED-CHARGE) MORTARS



**Rules Level:** Advanced

**Tech Base (Ratings):** Both (C/B-B-B)

**Game Rules:** Each shell in an Armor-Piercing 'Mech Mortar flight delivers 1 damage point to conventional infantry units (resolved as a missile Cluster weapon). Against all other units, the shaped-charge munitions inflict 2 damage points per shell, applied in 2-point groups. Each shell of Armor-Piercing 'Mech Mortar ammunition inflicts 2 points of damage in an ammunition explosion (multiplied as normal by the mortar rack's size and the total number of unfired rounds).

## FLARE MORTARS

**Introduced:** 2536 (Terran Hegemony)

Using phosphorescent chemicals and impact triggers, flare mortars ignite upon landing. Similar to smoke mortars, these shells are often used to mark targets, or to shed light on hidden units during nighttime combat.

## FLARE MORTARS

**Rules Level:** Advanced

**Tech Base (Ratings):** Both (B/A-A-A)

**Game Rules:** Flare Mortars are fired at a hex, rather than at a unit. A successful Flare Mortar attack illuminates the target hex and all adjacent hexes for a number of turns equal to twice the number of shells in the volley (so a 4-mortar volley would illuminate a target hex and its adjacent hexes for 8 turns). Each shell of Flare Mortar ammunition inflicts 1 point of damage in an ammunition explosion (multiplied as normal by the mortar rack's size and the total number of unfired rounds).

Missed Flare Mortar shots will scatter 1D6 hexes in a random direction.

## SEMI-GUIDED MORTARS

**Introduced:** 3064 (Free Worlds League)

As an eventual expansion on their semi-guided LRM concept, the Free Worlds League's munitions designers introduced a semi-guided form of the 'Mech mortar in an effort to revive the long-overlooked weapon system.

Though these more effective variations on shaped-charge mortars proved more accurate than standard shells, the experiment was only partially successful, as warriors continued to prefer more conventional missile systems.

## SEMI-GUIDED MORTARS

**Rules Level:** Advanced

**Tech Base (Ratings):** Inner Sphere (C/X-X-E)

**Game Rules:** Semi-Guided 'Mech Mortars receive the same benefits as Semi-Guided Missiles (see p. 142, *TW*) if their target is successfully "lit" by a friendly TAG unit. Otherwise, these mortars work in the same fashion as standard Armor-Piercing (Shaped-Charge) Mortars. Semi-Guided Mortars inflict the same damage as Armor-Piercing (Shaped-Charge) Mortars. Each shell of Semi-Guided 'Mech Mortar ammunition inflicts 2 points of damage in an ammunition explosion (multiplied as normal by the mortar rack's size and the total number of unfired rounds).

**Remote Sensors:** Remote Sensors are designated as ammunition for any unit equipped with a Remote Sensor Dispenser, but are also considered part of the dispenser itself, and count as part of its total weight. Additional bins for dispenser "ammo" may not be assigned to a unit (each dispenser and its sensors are considered a self-contained item).

Remote Sensors deployed by conventional infantry are covered under the Specialized Infantry rules (see p. 340).

## SMOKE MORTARS

**Introduced:** 2531 (Terran Hegemony)

Another common reload for mortar rounds, intended for mobile cover, training, or target-marking purposes, smoke mortars fill their targeted area with thick smoke.

### SMOKE MORTARS

**Rules Level:** Advanced

**Tech Base (Ratings):** Both (B/A-A-A)

**Game Rules:** Smoke Mortars are fired at a hex, rather than at a unit. On a successful attack, Smoke Mortars create a 2-level high plume of heavy smoke (see p. 47) in the target hex that lasts for a number of turns equal to twice the number of shells in the volley (so a 4-mortar volley would fill the target hex with Heavy Smoke for 8 turns). Each shell of exploding Smoke Mortars inflicts 1 point of damage in an ammunition explosion (multiplied as usual by the mortar's rack size and the total number of unfired rounds).

Missed Smoke Mortar shots will scatter 1D6 hexes in a random direction.

## REMOTE SENSORS

**Introduced:** 2590 (Terran Hegemony)

Available in an array of types, including motion detectors, thermal sensors, portable radar and EM scanners, modern remote sensors are often used to set up a perimeter defense network, but because they are readily destroyed and relatively expensive to produce, their utility on a fluid

battlefield waned through the Succession Wars. The return of Star League technology (which made mass deployment of such sensors viable) allowed for their revival in more recent years, but they remain susceptible to battlefield countermeasures.

### REMOTE SENSORS

**Rules Level:** Advanced

**Available To:** CI, BA, PM, BM, IM, CV, SV, AF, CF, SC, DS

**Tech Base (Ratings):** Both (E/E-F-E)

**Game Rules:** Remote Sensors are ineffective in space, as their range is severely limited. However, aerospace units capable of flying within 7 Altitudes of the ground—such as Airship and Fixed-Wing Support Vehicles, fighters, Small Craft and DropShips—may be used to deploy these sensors in game play by using the traditional Bombing rules (see pp. 245-247, *TW*). Ground vehicles, Naval vehicles, VTOLs, WiGEs, 'Mechs, ProtoMechs and battle armor equipped with a Remote Sensor Dispenser (see p. 236, *TM*), as well as conventional infantry designated as Sensor Engineers (a Combat Engineer platoon type; see p. 340), may deploy remote sensors at any point during their Movement Phase, at a cost of 1 MP.

Once deployed, all sensors settle to the surface of the underlying terrain (or float on the surface of the water, if deployed by naval units). Any friendly unit within 67 hexes (2 kilometers) of a deployed Remote Sensor can monitor the sensor's readings if the monitoring unit is equipped with one or more of the following systems: Active Probe, C<sup>3</sup> Master Computer, Improved C<sup>3</sup> Computer, Cockpit Command Console or Communications Equipment (1 ton or more). The maximum number of Remote Sensors each system can monitor is cumulative (see the Remote Sensor Monitor Table below). Sensor Specialist Infantry can monitor up to 2 Remote Sensors for every 7-trooper squad in the unit. Hostile ECMs that encompass a sensor's hex, or pass through a line of sight between the monitoring unit and a target sensor, will disrupt this link.

A Remote Sensor being monitored can be used to spot hidden units within 2 hexes of the sensor, unless such units are using Stealth Armor, Null-Signature System, Void-Signature System, or ECMs of any kind. Remote Sensors may be used to spot for LRM indirect fire and artillery attacks, but add a +3 to-hit modifier to any such attack. Remote Sensors may not operate as part of a C3 network.

Remote Sensors are easily spotted, and may be targeted and destroyed with any successful weapon attack on the sensor's hex that delivers 1 point of damage (or more). This attack receives the standard -4 immobile target modifier, but also applies a +2 to-hit modifier to account for the sensor's small size. Units passing through a sensor hex during their Movement Phase can also declare that they are destroying the sensor (by stepping on/driving over it), which costs 1 MP.

Though technically "ammunition" for Remote Sensor Dispensers, because they are treated as part of the dispenser equipment that deploys them, Remote Sensors are themselves destroyed when the dispenser is hit, and do not explode.

### REMOTE SENSOR MONITOR TABLE

Monitoring System	Max Remote Sensor Capacity
Active Probe, Light	1
Active Probe, Standard	2
C <sup>3</sup> Master Computer	4
Improved C <sup>3</sup> Computer	3
Cockpit Command Console	4
Communications Equipment	1 per ton
Sensor Engineer Infantry	2 per squad

INTRODUCTION

ADVANCED  
GROUND MOVEMENT

ADVANCED  
COMBAT

ADVANCED  
BUILDINGS

ADVANCED  
SUPPORT  
VEHICLES

GENERAL  
RULES

ADVANCED  
SUPPORT VEHICLE  
CONSTRUCTION

ADVANCED  
WEAPONS  
AND EQUIPMENT

INDEX

RECORD SHEETS

# ADVANCED CONSTRUCTION OPTIONS

The following additional rules do not reflect components for construction units per se, but modifications to the existing design rules that can add greater flexibility to a design. These options can be used together or separately, offering a greater degree of variance in home-grown units, but reflect experimental-level unit design and are not generally compatible with tournament game play.

## FRACTIONAL ACCOUNTING

Fractional accounting relaxes the rounding procedures established by the standard construction rules for various units, paving the way for a more fine-tuned distribution of weight across a unit's design. Under fractional accounting, every component with a calculated weight that the designer is instructed to round up, down or normally to the nearest half ton may ignore such rounding instructions and retain all fractions unchanged. Any item described using the phrase "or fraction thereof," however (such as the gyroscope), must be rounded up.

Fractional rounding can be especially effective when dealing with engine, armor and ammunition weights, as further defined below.

Though open to great flexibility, components and units using fractional accounting should still round any figures up to the nearest kilogram (0.001 tons), to keep accounting simple. For this reason, fractional accounting is less useful when finding component weights for Small-sized Support Vehicles (which already use a kilogram standard for construction purposes).

## Engines

Under fractional accounting, the weight of many military engines (used by BattleMechs, IndustrialMechs, Combat Vehicles and fighters) can be further refined as well. Standard fusion engines and their internal combustion equivalents (including those in the Large Engine category) remain the same under this approach, while their alternative forms (Compact, Light, XL, XXL, Fuel Cell and Fission) are generally rounded up in standard construction.

With fractional accounting, these engines receive a weight multiplier that can be used instead of the table references given in *TechManual* (or the Large Engine table on p. 308). To find the weight of a given military engine type, multiply its standard fusion engine weight by the value for that engine type listed in the Fractional Engine Multipliers table shown in the Fractional Accounting Tables below. Do *not* round the final result to the nearest half-ton. For example, a 350-rated standard fusion engine weighs 29.5 tons; its light fusion equivalent (with a fractional multiplier of 0.75) would weigh 22.125 tons (rather than the 22.5 tons listed in *TechManual*).

Support Vehicle engines under fractional accounting are computed per their normal rules, but need not round off their final values to the nearest half-ton.

Fractional accounting does not alleviate any engine weight minimums imposed by the vehicle or engine design, and so even under this method, hovercraft still require a minimum 20 percent of total mass in engine weight, while fusion engines may not be

constructed lighter than 0.25 tons and fission engines may not be built lighter than 5 tons.

## Armor

When using fractional accounting, armor may be installed on a unit in any desired quantity, rather than in full- or half-ton allotments. In this case, armor may be installed on a tonnage-per-point basis, per the Fractional Armor Table. (Remember when using Support Vehicle armor that the weight per point is given in kilograms for Support Vehicle construction; to find the equivalent weight in tons per point, simply divide the kilogram weight by 1,000.)

Critical requirements for a given unit do not change with the amount of armor mounted on it (unless using the Patchwork Armor rule; see p. 377).

## FRACTIONAL ACCOUNTING TABLES

### FRACTIONAL ENGINE MULTIPLIERS

Engine Type	Fractional Multiplier
<i>Fusion</i>	
Standard	1.0
Compact	1.5
Light	0.75
XL	0.5
XXL	0.333
<i>Non-Fusion</i>	
Internal Combustion (ICE)	2.0
Fuel Cell (Cell)	1.2
Fission	1.75

### FRACTIONAL ARMOR TABLE

Armor Type	Tons per Point
Standard/Heavy Industrial	0.0625
Stealth	0.0625
Light Ferro-Fibrous	0.0590
Ferro-Fibrous (I.S.)	0.0558
Ferro-Fibrous (Clan)	0.0521
Heavy Ferro-Fibrous	0.0504
Industrial	0.0933
Commercial	0.0417
Support Vehicle	See p. 134, <i>TM</i> *
Ferro-Lamellor	0.0714
Hardened	0.1250
Laser-Reflective (I.S.)	0.0625
Laser-Reflective (Clan)	0.0625
Modular	N/A
Reactive (I.S.)	0.0625
Reactive (Clan)	0.0625
Vehicular Stealth	0.0625

\*To convert Support Vehicle armor from kilograms per point to tons per point, divide the values shown in the referenced table by 1,000.

## Ammo

Fractional accounting also allows units to carry ammunition in quantities other than full-ton (or half-ton) lots. Under these rules, units can mount any desired amount of ammo instead, computing the ammo's weight per shot by dividing a full-ton bin by its number of shots. (For example, a shot of MG ammo weighs 0.005 tons [1 ton ÷ 200 shots per ton = 0.005 tons per shot], while a shot of SRM 4 ammo weighs 0.04 tons [1 ton ÷ 25 shots per ton = 0.040 tons per shot].)

For 'Mech units using these rules, remember that ammunition still consumes 1 critical slot for every full ton (or fraction thereof) carried by a weapon. For non-'Mech units, only 1 slot is required per type of ammunition.

## MIXED TECHNOLOGIES

Under standard rules, Clan and Inner Sphere technologies cannot be combined on the same chassis of any unit type, nor can units mounting tournament legal and/or advanced technologies be combined with those that employ experimental technologies. In actuality, battlefield salvage and field-testing have opened the door to hybrid units where standard Inner Sphere technologies cross over with equipment of Clan or even experimental origins.

Any unit may be constructed using a mix of Clan and Inner Sphere technologies, including those described as tournament-legal (with rules described in *TechManual*), advanced or experimental. All such items follow their relevant construction rules when installed, including any requirements for heat sinks and power amplifiers. Both structural items (such as internal structure, cockpits, musculature and engines) and non-structural components (such as weapons and heat sinks) may be taken from different technology bases. However, as the original rules for such items pre-supposed their incompatibility, players must use their judgment to resolve any discrepancies in the rules regarding their use.

## PATCHWORK ARMOR

A special variation on armor installation, "patchwork" armor describes mounting armor of varying types on the same unit. Though no major manufacturers in the Inner Sphere, Periphery or Clan space produce units with multiple armor types, centuries of scavenging and maverick technicians (by whim or by necessity) have sent many units into the field with patchwork armor. Under this advanced construction option, units may vary their armor types by location, rather than assigning a single type and uniform application across the entire unit.

Only 'Mechs, Combat Vehicles, Support Vehicles with the Armored Chassis modification and fighters may mount patchwork armor (infantry, battle armor, ProtoMechs, other aerospace units and Mobile Structures may not vary their armor types across the unit). The designer of a unit must designate the armor type to be used in each hit location and—using the Fractional Armor Table described earlier—compute the weight of the armor by multiplying its weight (in tons per point) by the number of points assigned to the location, rounding the final result up to the nearest half-ton. In addition, for armor that takes up critical slots, each location selected to feature that particular armor type must allocate a number of critical slots as noted in the Space (per Location) column of the Patchwork Armor Table below. In this case, the required slot space for

'Mechs and Support Vehicles is noted to the left of the slash, and the slot space for Combat Vehicles and fighters is noted on the right of the slash. If slot space is unavailable to mount an armor type in a given location—even after removing equipment and optional components such as lower arm and hand actuators—the desired armor type may not be mounted there.

Even under patchwork armor rules, a unit may not mount multiple armor types in the same location (including locations with a front and rear facing, such as 'Mech torsos).

Remember that even with patchwork armor, all normal armor maximum rules still apply for all unit types. For example, a 'Mech's arm can only support a number of armor points equal to twice its internal structure points in that location, and the armor maximums for fighters and vehicles may not be exceeded by any combination of patchwork armor points.

*A player with an old-model GRF-1N Griffin with standard armor opts to use patchwork armor rules to mount some salvaged Inner Sphere ferro-fibrous armor on its right arm. The 55-ton BattleMech's arm has an Internal Structure Value of 9, and—with its fully actuated arm and PPC mount there—has 5 open critical slots in that location. Consulting the tables, the Griffin's player finds that*

## PATCHWORK ARMOR TABLE

Armor Type	Space (per Location)*	Notes
Standard/Heavy Industrial	0 / 0	Available to all units
Stealth	2 / 1	No stealth mods when installed as patchwork
Light Ferro-Fibrous	1 / 1	
Ferro-Fibrous (I.S.)	2 / 1	
Ferro-Fibrous (Clan)	1 / 1	
Heavy Ferro-Fibrous	3 / 2	
Industrial	0 / 0	
Commercial	0 / 0	BAR 5
Support Vehicle	0 / 0	
Ferro-Lamellor	2 / 1	
Hardened	0 / 0	All except VTOL, WiGE, Hover, Airship, or Fixed-Wing**
Laser-Reflective (I.S.)	2 / 1	
Laser-Reflective (Clan)	1 / 1	
Modular	N/A	Modular Armor is treated as an item, not as armor
Reactive (I.S.)	2 / 1	
Reactive (Clan)	1 / 1	
Vehicular Stealth	NA / 1	No stealth mods when installed as patchwork

\*Number left of slash applies to 'Mechs and Support Vehicles; Number right of slash is for Combat Vehicles and fighters.

\*\*If no Hardened Armor is mounted in the unit's legs, the movement modifiers for using Hardened Armor do not apply (see p. 280).

INTRODUCTION

ADVANCED  
GROUND MOVEMENT

ADVANCED  
COMBAT

ADVANCED  
BUILDINGS

ADVANCED  
SUPPORT  
VEHICLES

GENERAL  
RULES

ADVANCED  
SUPPORT VEHICLE  
CONSTRUCTION

ADVANCED  
WEAPONS  
AND EQUIPMENT

INDEX

RECORD SHEETS

each point of armor placed on the arm will weigh 0.0558 tons, and that mounting the armor there will require 2 critical slots. Going for broke, the player decides to mount the maximum armor value possible for the location: 18 points (9 x 2 = 18), and finds that this armor will weigh 1.5 tons (0.0558 x 18 = 1.0044, round up to 1.5 tons). To avoid wasting an extra half-ton, the player opts for 17 points instead, which will weigh 1 ton (0.0558 x 17 = 0.9486, round up to 1 ton).

## SUPER-HEAVY VEHICLES

This Super-Heavy Vehicle construction option enables designers to exceed the standard weight limits established in the construction rules for Combat Vehicles in *TechManual*, effectively creating a new weight class for such vehicles (Super-Heavy). These rules apply only to the construction of select Combat Vehicles, however, and not to Support Vehicles and other battlefield units.

Construction of super-heavy vehicles follows the same procedures and rules as detailed in *TechManual* (see pp. 94-109), but with the following exceptions:

- Combat Vehicles built with a Tracked, Wheeled, Hover, VTOL, or WIGE motive system, as well as Displacement Hull and Submarine Naval Vehicles, may all be built as super-heavy vehicles. Hydrofoil Combat Vehicles may not be built in the Super-Heavy weight class. The maximum attainable weight for each of these units under the Super-Heavy Construction rules is shown in the Super-Heavy Combat Vehicle Table below.
- Combat Vehicles may use any engine type permitted for Combat Vehicles—including, if desired, the Large-sized engines presented on p. 308. Where applicable, each motive type applies its Suspension Factor when computing Engine Ratings. A Combat Vehicle must be constructed with at least 1 Cruise MP.
- All Non-Naval Super-Heavy Combat Vehicles compute their internal structure weight as 20 percent of the vehicle's total weight, rather than 10 percent. Round this value up to the nearest half-ton.
- All Super-Heavy Combat Vehicles use the Super-Heavy Vehicle Hit Locations Table, and must apply armor and structure to 6 facings (plus any rotors or mounted turrets) rather than 4. These facings are: Front, Front-Left, Front-Right, Rear-Left, Rear-Right, and Rear. The amount of internal structure all Super-Heavy Combat Vehicles receive in each location is equal to the unit's tonnage, divided by 10, rounded up.

## Super-Heavy Combat Vehicle Game Rules

Super-Heavy Combat Vehicles of all kinds follow the standard rules for gameplay as their standard weight relatives (though Super-Heavy Ground Vehicles use the Large Ground Support Vehicle Hit Location Table; see p. 206, *TW*), but use the appropriate Super-Heavy Vehicle Record Sheet to track damage and determine armor facings.

## ULTRA-LIGHT BATTLEMECHS

Though rare in the extreme, a few ultra-light BattleMechs are known to exist. To construct a 10 or 15 ton ultra-light BattleMech, use all the standard BattleMech construction rules, but use the IndustrialMech Ultra-Light Internal Structure Table (see p. 66, *TM*) to determine internal structure; note that BattleMechs only pay ten percent for their internal structure, so divide the Industrial Standard weight shown on the table for both tonnages by 2 to find the appropriate internal structure weight for BattleMechs.

Ultra-Light BattleMechs follow all the standard rules for gameplay as any other BattleMech.

# ADVANCED BATTLE VALUES

The following rules are additions and/or adjustments to those presented in the *Tech Manual* (pp. 302-313). They allow players to calculate the Battle Value for any unit employing the new equipment introduced in *Tactical Operations*.

## SATELLITES

Use the rules for calculating an Aerospace BV (see p. 312-313, *TM*) to find the BV of a satellite. Satellites have a Vehicle Type Modifier of 0.7 when computing Defensive Battle Rating. When calculating their Offensive Battle Rating, satellites find their Speed Factor based on a Maximum Thrust of 0.

## RAIL VEHICLES

Use the rules for calculating a Vehicle BV (see p. 307-309, *TM*) to find the BV of a Rail vehicle. Rail units have a Vehicle Type Modifier of 0.6 when computing Defensive Battle Rating. When calculating their Offensive Battle Rating, Rail vehicles use their Cruise MP rate, rather than their Flank MP rate, when finding their Speed Factor (to account for their track-based limitations).

## SUPER-HEAVY COMBAT VEHICLE TABLE

Combat Vehicle Motive Type	Super-Heavy Weight (tons)	Suspension Factor	Terrain Restrictions
Hover	51-100	235 + (45 for every 25 tons* over 50)	No Woods/Jungle
Naval (Displacement)	301-555	(Tonnage ÷ 10, rounded up to the nearest 5)	Water hexes only (Depth 1+)
Naval (Submarine)	301-555	(Tonnage ÷ 10, rounded up to the nearest 5)	Water hexes only (Depth 1+)
Tracked	101-200	0	No Heavy+ Woods/Jungle or Water Depth 1+
Wheeled	81-160	40	No Woods/Jungle, Rough, Rubble, or Water (Depth 1+)
VTOL	31-60	140 + (45 for every 20 tons* over 30)	No Woods, Hills, or Structures at same elevation
Wing-in-Ground (WIGE)	81-160	140 + (35 for every 30 tons* over 80)	No Woods, Hills, or Structures at same elevation

\*Or fraction thereof

## LARGE-SIZED AIRSHIPS

Use the rules for calculating an airship's BV (see p. 312-313, *TM*) to find the BV of a Large-sized airship.

## LARGE-SIZED NAVAL VESSELS

Use the rules for calculating a Vehicle BV (see p. 307-309, *TM*) to find the BV of a Large-sized naval vessel.

## MOBILE STRUCTURES

The procedure for calculating the Battle Value (BV) of mobile structures is similar to that of other units, as described below.

### STEP 1: CALCULATE DEFENSIVE BATTLE RATING

First, **ADD** the following figures:

**Total Armor Factor x 2.5**

**Total CF x 1.5**

#### Total BV of all Defensive Equipment

Defensive equipment includes active probes, anti-missile systems (including AMS ammo, up to the BV of the systems themselves) and ECM suites. Other Defensive Equipment items are identified on the Weapon and Equipment Battle Value Tables by a dagger footnote (†).

Next, **MULTIPLY** the current value by 0.5. This final result is the mobile structure's Defensive Battle Rating (DBR).

### STEP 2: CALCULATE OFFENSIVE BATTLE RATING

Calculate the Offensive Battle Rating. This is done by **MULTIPLYING** the Weapon Battle Rating by the mobile structure's speed factor.

#### Calculate the Weapon Battle Rating

First, add the BV ratings of all remaining weapons and equipment. Unlike most other units, Mobile structures do not modify the BV of weapons that fall outside their "forward" arc.

To prevent excessive ammo from distorting the Battle Value, the BV added for ammunition cannot exceed the Battle Value of the weapon itself. If the ammo BV exceeds that of the weapon, reduce the ammo BV to match the unmodified weapon BV. If a mobile structure is armed with several weapons of the same model, total the BV for that model and the ammunition carried before comparing the two BVs.

**Add Number of Mobile Structure Hexes x 50**

**Multiply the Weapon Battle Rating by the mobile structure's Speed Factor**

Multiply the mobile structure's Base Weapon Rating and Speed Factor to determine its Offensive BV. Use the mobile structures maximum MP rating.

### STEP 3: CALCULATE THE FINAL BV

Add the Defensive and Offensive Battle Value Ratings and round the resulting sum to the nearest whole number (0.5 rounds up). The result is the mobile structure's BV.

This formula yields a BV of a mobile structure controlled by personnel with the standard Gunnery 4 and piloting 5 skill levels. If personnel with a different skill level controls the mobile structure, multiply the BV by the appropriate skill level multiplier (see *Construction a Battle Force*, *TM* p. 314).

## DEFENSIVE FACTORS MODIFIER TABLE [ADDENDUM]

Special Case	Defensive Factor Modifier*
<i>Beast Mounted Infantry</i>	–
Very Large	–0.1
Monstrous	–0.2
<i>Advanced Infantry Armor</i>	–
DEST Infiltration Suit	+0.1
Sneak, Camo	+0.2
Sneak IR	+0.2
Sneak ECM	+0.1

\*Modifiers are cumulative.

## ADVANCED INFANTRY

Although the process for calculating the Battle Value (BV) of an advanced infantry unit is fundamentally the same as that for conventional infantry (see p. 309, *TM*), the additional options available offer radical new effects on such units' BV. These minor changes are detailed below.

### STEP 1: CALCULATE DEFENSIVE BATTLE RATING

**CALCULATE** the Base Defensive Battle Rating. The damage divisors are provided by the type of armor worn by the infantry (see p. 317), and from their mounts (if beast-mounted; see p. 295).

**Sum of Damage Divisors x 1.5**

Next, **MULTIPLY** this by the Defensive Movement Factor, which is based on the unit's highest potential target modifier (including bonuses for jump capability and stealth armor), as shown on the Defensive Factors Modifiers Table (above).

Finally, **MULTIPLY** this value by the number of troopers in the unit. This final result is the advanced infantry unit's Defensive Battle Rating.

### STEP 2: CALCULATE OFFENSIVE BATTLE RATING

To calculate the Offensive Battle Rating, **ADD** the following:

**Total Weapon Battle Rating**

**Battle Value of all Field Guns/Field Artillery and ammunition.**

**Battle Value of all Disposable weapons x 0.2**

**Anti-'Mech Battle Rating**

Next, **MULTIPLY** this sum by the unit's Speed Factor to determine its Offensive BV Rating. Use the infantry unit's fastest movement model (for example, jump infantry use Jumping movement).

### STEP 3: CALCULATE FINAL BATTLE VALUE

Add the Defensive Battle Rating to the Offensive Battle Rating. Multiply the result by the values from the Unit Type Modifiers Table (p. 381), and round to the nearest whole number (0.5 rounds up).

This formula yields the Battle Value of an infantry unit with the standard Gunnery 4 and Anti-'Mech 5 Skill levels. If the unit possesses higher or lower skill levels, multiply the BV by the appropriate skill level multiplier (see *Construction a Battle Force*, p. 314, *TM*)

INTRODUCTION

ADVANCED  
GROUND MOVEMENT

ADVANCED  
COMBAT

ADVANCED  
BUILDINGS

ADVANCED  
SUPPORT  
VEHICLES

GENERAL  
RULES

ADVANCED  
SUPPORT VEHICLE  
CONSTRUCTION

ADVANCED  
WEAPONS  
AND EQUIPMENT

INDEX

RECORD SHEETS

# ADVANCED WEAPONS AND EQUIPMENT

The following rules and tables outline how the new equipment presented earlier in the Advanced Weapons and Equipment section apply to Battle Value calculations.

**Equipment Battle Values:** Note that any equipment introduced in *TechManual* or in this book that is not included in the Inner Sphere and Clan Equipment and BV Tables (p. 382–385) is considered to have a BV of 0 for the purposes of calculating a unit's Battle Value.

## ACTUATOR ENHANCEMENT SYSTEM

Multiply by 1.5 the unmodified BV of any weapons (including all physical attack weapons, but not including any ammunition) linked to an AES. In addition, when calculating the Offensive Battle Rating, add 10 percent to the 'Mech's total tonnage for each limb mounting an AES. This adjustment is made before the multiplier for TSM is applied.

*A Zeus mounts an AES in the right arm along side a heavy PPC. When calculating the Offensive Battle Rating, the Zeus is computed as if it weighs 88 tons (80 tons, plus 10 percent). If the assault 'Mech was also outfitted with Triple-Strength Myomer, then the 1.5 multiplier for that equipment would be applied to the new value of 88.*

## ARMOR

Under *TechManual* rules, only 'Mechs used the 'Mech Armor Type Modifier Table. The advanced armor types made available under *Tactical Operations* allow other units to use alternative armor types. When calculating the Defensive Battle Rating for armor for all units except infantry, apply an additional modifier from the Armor Type Modifier Table, at right.

Where other considerations impact on the BV calculation process, see below.

**Hardened Armor/Shields:** The movement modifier applied to BattleMechs using Hardened Armor or Shields must be taken into account when calculating the unit's Defensive Movement Factor and Speed Factor.

**Modular Armor:** Modular Armor increases the total armor carried. Include this additional armor when calculating the Defensive Battle Rating using the Armor Type Modifier for the armor fitted in the same location as the modular armor.

**Vehicular Stealth Armor:** The vehicle uses the same modifiers as a 'Mech equipped with stealth armor. Aerospace and Conventional Fighters add an extra 0.3 to their unit type modifier.

## ARMORED COMPONENTS

The Defensive Battle Rating of an armored component is equal to 5 percent of the BV of the item protected per slot. If the item has no BV, then the value is 5 points per slot.

## BATTLE ARMOR MECHANICAL JUMP BOOSTER

Include the Jump MP bonus provided by a Mechanical Jump Booster when determining the unit's Defensive Movement Factor and Speed Factor.

## ARMOR TYPE MODIFIER TABLE (NEW)

Armor Type	Modifier
Blue Shield PDF	+0.2*
Commercial	0.5
Ferro Fibrous (All)	1.0
Ferro-Lamellor	1.2
Hardened	2.0
Heavy Industrial	1.0
Industrial	1.0
Laser Reflective	1.5
Modular	**
Reactive	1.5
Standard	1.0
Stealth	1.0

\* Add 0.2 to the unit's Armor Type Modifier

\*\* Equal to the modifier for the type of armor installed in the same location

## BATTLE ARMOR MYOMER BOOSTER

Include the additional Jump MP provided by a Battle Armor Myomer Booster when determining the unit's Defensive Movement Factor and Speed Factor.

## BATTLE ARMOR DETACHABLE WEAPON PACK

Battle Armor outfitted with a detachable weapon pack use their standard movement rates (after all weapon packs are detached) when determining the unit's Defensive Movement Factor and Speed Factor.

## BATTLEMECH MECHANICAL JUMP BOOSTERS

Calculate BV as normal using maximum jump distance.

## BATTLEMECH/PROTOMECH PARTIAL WING

Calculate BV as normal using maximum jump distance (with the Partial Wing bonus) under standard atmospheric conditions.

## BATTLEMECH UMU SYSTEM

Calculate as if equipped with jump jets. If Mechanical Jump Boosters are installed, then use the highest movement mode of the two.

## BLUE SHIELD PFD

When calculating the Defensive Battle Rating of a 'Mech outfitted with a BSPFD add 0.2 to the unit's Armor Type Modifier and Internal Structure Type Modifier. Vehicles mounting a BSPFD adjust the Defensive Battle Rating armor and internal structure values using the same Armor Type Modifiers and Internal Structure Type Modifiers as a 'Mech. In a similar manner, aerospace units apply the same modifier to their Armor Type Modifiers. The Internal Structure Type Modifier is applied to the aerospace unit's Structural Integrity.

A 'Mech mounting a Blue Shield treats it as a Gauss weapon with critical space in every location except the head when adjusting the Defensive Battle Rating for explosive components.

A Thunderbolt has been modified to carry a Blue Shield PDF. Normally the standard armor would give it an Armor Type Modifier of 1.0, but with the Blue Shield that increases to 1.2. Lacking CASE in any location, the Thunderbolt must also subtract a total of 6 points from its Defensive Battle Rating (1 for every location except the head) to account for the PDF's explosive nature.

## CASE II

No reduction is made to the Defensive Battle Rating for ammunition or Gauss weapons mounted in the same location as CASE II.

## CHAMELEON LIGHT POLARIZATION SHIELD

When calculating the BV of a unit equipped with a Chameleon Light Polarization Shield, add the long-range to-hit modifier when calculating the unit's Defensive Factor, but do not include the 6 points of heat generated by the system in all heat efficiency calculations.

## COCKPIT SYSTEMS – TORSO-MOUNTED COCKPIT

A torso-mounted cockpit significantly improves the BattleMech's chances of survival, especially if the 'Mech has ample center-torso armor. To reflect this, double the center torso armor (front and rear, combined) when computing the 'Mech's total armor factor (and before applying any Armor Type Modifiers) for the base Defensive Battle Rating. The Piloting Skill modifier must also be applied to the unit's final Battle Value as well.

## COMBAT VEHICLE CHASSIS MODIFICATIONS

When calculating the BV of a combat vehicle possessing chassis modifications add the modifiers for all modifications to the Unit Type Modifier (see Unit Type Modifiers Table at right).

## COOLANT POD

When computing a the heat sink capacity of a unit using Coolant Pods, add the following value to the unit's heat sink capacity: (Number of Heat Sinks carried x [Number of Coolant Pods ÷ 5]), rounded up to the nearest whole—to a maximum value of twice the unit's number of heat sinks.

Also, for Defensive BV calculations, subtract 1 point per Coolant Pod slot, to reflect the explosive nature of this item.

## ENGINE SYSTEMS

'Mechs use the expanded 'Mech Engine Type Modifier Table (at right). Alternative engines have no impact on the BV calculations for other units.

## HANDHELD WEAPONS

The hand-held weapon has its own BV, which is the total of the BV values of the weapons and ammunition it includes, plus any armor it mounts (Armor Factor x 2). When a 'Mech carries the handheld weapon, this BV is added directly to the unit's final BV.

## LASER ANTI-MISSILE SYSTEM

The Laser Anti-Missile System counts as a piece of Defensive Equipment when computing a unit's Defensive Battle Rating.

## UNIT TYPE MODIFIERS TABLE [ADDENDUM]

Type	Modifier
Foot/Beast Mounted Infantry	1.0
Motorized Infantry	0.8
Tracked	0.9
Wheeled	0.8
Hover	0.7
Naval	0.6
VTOL	0.7
Airship	0.7
Fixed-Wing	1.0
WiGE	0.7
Aerospace Fighter	1.2
Conventional Fighter	1.1
Small Craft	1.0
DropShip	1.0
Rail	0.6
Satellite	0.7
Fixed Structure	0.25
Mobile Structure	0.5
<i>Combat Vehicle Chassis Modifiers</i>	
Floataion Hull	+0.1
Limited Amphibious	+0.1
Fully Amphibious	+0.2
Dune Buggy Modification	+0.1
Environmental (Vacuum) Sealing	+0.1
<i>Specialized Infantry Type Modifiers</i>	
Combat Engineers	+0.1
Marines	+0.3
Mountain Troops	+0.2
Paratroops	+0.1
SCUBA	+0.1
<i>Special Cases</i>	
Aerospace Fighter with Stealth Armor	+0.3
Conventional Fighter with Stealth Armor	+0.3
Infantry created as XCT Troops	+0.1
Vehicles using Armored Motive Systems	+0.1

## 'MECH ENGINE TYPE MODIFIER TABLE [ADDENDUM]

Armor Type	Modifier
Large	1.125
XXL (IS)	0.5
XXL (Clan)	0.75
Large XXL (IS)	0.375
Large XXL (Clan)	0.5

INTRODUCTION

ADVANCED  
GROUND MOVEMENT

ADVANCED  
COMBAT

ADVANCED  
BUILDINGS

ADVANCED  
SUPPORT  
VEHICLES

GENERAL  
RULES

ADVANCED  
SUPPORT VEHICLE  
CONSTRUCTION

ADVANCED  
WEAPONS  
AND EQUIPMENT

INDEX

RECORD SHEETS

### LASER INSULATOR

When calculated heat generated by a unit, reduce the heat levels by 1 for each weapon equipped with a laser insulator.

### LASER – VARIABLE SPEED PULSE

See the Weapons and Equipment BV Table for the BV for large, medium, and small VSP lasers, but use the maximum heat levels these weapons generate when making BV adjustments for heat.

### NULL-SIGNATURE SYSTEM

When calculating the BV of a unit equipped with a Null-Signature System, add the long-range to-hit modifier when calculating the unit's Defensive Factor, but do not include the 10 points of heat generated by this system in all heat efficiency calculations.

### PATCHWORK ARMOR

Calculate the modified Defensive Battle Rating on a location-by-location basis, and then sum the total before multiplying by 2.5 to get the armor DBR.

### PPC CAPACITOR

See the Weapons and Equipment BV Table for the modified BV for PPC weapons fitted with a PPC capacitor. Include the heat generated by the capacitor with that generated by the weapon with which it is paired when determining heat values and BV adjustments.

### SHIELDS

Include the ground movement modifier when computing the Defensive Factors and Speed Factors of units equipped with a medium or large shield. If a 'Mech carrying a large shield is also jump capable, use the jump movement rating as normal.

### STRUCTURE

For the modifiers appropriate to the new internal structure options for 'Mech construction, see the 'Mech Internal Structure Modifier Table [Addendum] below.

### SUPERCHARGER

Use the maximum speed provided by the Supercharger when calculating the Defensive and Speed Factors.

### TURRETS

All weapons and equipment mounted on a 'Mech in a turret is counted as being in the front firing arc if the Offensive BV of all forward-firing non-turret mounted equipment is greater than that of rear-firing non-turret mounted equipment (otherwise it is treated as being in the rear arc).

### VEHICULAR JUMP JETS

Use jump movement like a 'Mech when calculating Defensive and Speed Factors

### VOID-SIGNATURE SYSTEM

When calculating the BV of a unit equipped with a Void-Signature System, include the maximum +3 to-hit modifier when calculating the Defensive Factor, but do not include the 10 points of heat generated by this system in all heat efficiency calculations.

### VTOL-JET BOOSTER

Use the maximum speed provided by the VTOL Jet Booster when calculating the Defensive and Speed Factors.

### VTOL MAST MOUNT

Add 10 points to the base Weapons Battle Rating for a VTOL mast mount.

## INNER SPHERE WEAPONS AND EQUIPMENT BV TABLE [ADDENDUM]

Item	Item BV	Ammo BV
<i>Energy Weapons</i>		
ER Flamer	16	—
Binary Laser	296	—
Bombast Laser	137	—
VSP Laser (Large)	123	—
VSP Laser (Medium)	56	—
VSP Laser (Small)	22	—
X-Pulse Laser (Small)	21	—
X-Pulse Laser (Medium)	71	—
X-Pulse Laser (Large)	178	—
PPC (Heavy) + PPC Capacitor	370	—
PPC + PPC Capacitor	264	—
PPC (Light) + PPC Capacitor	132	—
PPC (Snub-nose) + PPC Capacitor	252	—
ER PPC + PPC Capacitor	343	—
Laser Anti-Missile System	45†	—
<i>Ballistic Weapons</i>		
HV AC/2	53	7
HV AC/5	109	14
HV AC/10	158	20
Fluid Gun	6	1
Heavy Flamer	15	2
Improved Heavy Gauss	385	48
MagShot	15	2
Silver Bullet Gauss	198	25
'Mech Mortar/1	10	1
'Mech Mortar/2	14	2
'Mech Mortar/4	26	3
'Mech Mortar/8	50	6
Rifle (Light)	21	3

## 'MECH INTERNAL STRUCTURE MODIFIER TABLE [ADDENDUM]

Internal Structure Type	Modifier
Blue Shield PDF	+0.2*
Composite	1.0
Endo-Composite	1.0
Reinforced Structure	2.0

\* Add 0.2 to the unit's Internal Structure Type Modifier

## INNER SPHERE WEAPONS AND EQUIPMENT BV TABLE [ADDENDUM]

Item	Item BV	Ammo BV
Rifle (Medium)	51	6
Rifle (Large)	91	11
Vehicular Grenade Launcher	15	—
Taser, BattleMech	40†	5
Taser, Battle Armor	15	—
Artillery Cannon, Long Tom	329	41
Artillery Cannon, Sniper	77	10
Artillery Cannon, Thumper	41	5
<i>Missile Weapons</i>		
Enhanced LRM-5	52/10	7
Enhanced LRM-10	104/21	13
Enhanced LRM-15	157/31	20
Enhanced LRM-20	210/42	26
ELRM-5	67/13	8
ELRM-10	133/27	17
ELRM-15	200/40	25
ELRM-20	268/54	34
Thunderbolt-5	64/13	8
Thunderbolt-10	127/25	16
Thunderbolt-15	229/46	29
Thunderbolt-20	305/61	38
<i>Artillery Weapons</i>		
Arrow IV	240	30
Long Tom	368	46
Sniper	85	11
Thumper	43	5
Cruise Missile/50	601	75
Cruise Missile/70	1,031	129
Cruise Missile/90	1,530	191
Cruise Missile/120	2,281	285

† Defensive BV.

‡ Treat as Gauss weapon when calculating defensive battle rating.

**C CASE/MASC/Triple Strength Myomer/Industrial Triple Strength Myomer/Supercharger:** Thought these items are used when calculating Battle Ratings, they have no individual BV

**D C<sup>3</sup> Computers/Slaves and Improved C<sup>3</sup> Computers:** C<sup>3</sup> Computers and Slaves (or Improved C<sup>3</sup> Computers, Boosted C<sup>3</sup> Emergency C<sup>3</sup> Masters, and Naval C<sup>3</sup>) only affect a unit's BV if the unit is designated as part of a complete C<sup>3</sup> network (at least one C<sup>3</sup> Master and one Slave, or two Improved C<sup>3</sup> Computers). See *Constructing a Battle Force [Addendum]*, p. 386

**G Actuator Enhancement System:** The BV of an AES equals 50 percent of the total BV of all weapons (including all physical attack weapons) linked to the AES. Do not include the BV of ammo when calculating this sum.

**H CASE II:** Though these items are used when calculating the Defensive Battle Rating, they have no individual BV.

Item	Item BV	Ammo BV
<i>Melee Weapons</i>		
Chain Whip	(Dmg x 1.725)	—
Claws	(Dmg x 1.275)	—
Flail	11	—
Lance	(Dmg x 1)	—
Mace	(Dmg x 1)	—
Shield, Small	50†	—
Shield, Medium	135† N	—
Shield, Large	263† N	—
Spikes	4†	—
Vibroblade, Small	12	—
Vibroblade, Medium	17	—
Vibroblade, Large	24	—
<i>Other Equipment</i>		
Actuator Enhancement System	G	—
Angel ECM Suite	100†	—
Armored Components	J	—
Bloodhound Active Probe	25†	—
CASE II	H	—
C <sup>3</sup> , Battle Armor	D	—
C <sup>3</sup> , Boosted System	D	—
C <sup>3</sup> , Emergency Master	D	—
C <sup>3</sup> , Remote Sensor Launcher	30	6
Chaff Pod	19†	—
Electronic Warfare Equipment	K	—
MASS	9	—
M-Pod	5	—
MRM "Apollo" FCS	L	—
Mine Dispenser	P	—
Minesweeper	30†	—
Naval C <sup>3</sup>	D	—
Supercharger	C	—
VTOL Mast Mount	M	—

**J Armored Components:** The Defensive Battle Rating of an armored component is equal to 5 percent of the BV of the item protected per slot. If the item has no BV, then the BV is 5 points per slot.

**K Electronic Warfare Equipment:** Offensive BV 8, Defensive BV 31.

**L MRM "Apollo" FCS:** Increase by 15 percent the BV of any MRM launcher equipped with an Apollo FCS.

**M VTOL Mast Mount:** Add 10 to the BV of mast mounted weapons and equipment.

**N Shields:** Include the ground movement modifier for medium or large shields. If a 'Mech is carrying a large shield but is also jump capable, use the jump movement rating as normal.

**P Mine Dispenser:** BV is equal to a 10 point minefield of the appropriate type of mine.

INTRODUCTION

ADVANCED  
GROUND MOVEMENT

ADVANCED  
COMBAT

ADVANCED  
BUILDINGS

ADVANCED  
SUPPORT  
VEHICLES

GENERAL  
RULES

ADVANCED  
SUPPORT VEHICLE  
CONSTRUCTION

ADVANCED  
WEAPONS  
AND EQUIPMENT

INDEX

RECORD SHEETS

## INNER SPHERE CAPITAL SCALE WEAPONS AND EQUIPMENT BV TABLE [ADDENDUM]

Item	Item BV	Ammo BV
<i>Mass Driver</i>		
Mass Driver (Light)	7,056	882
Mass Driver (Medium)	11,760	1,470
Mass Driver (Heavy)	16,464	2,058
<i>Naval Autocannon</i>		
Light SCC	379	47
Medium SCC	708	89
Heavy SCC	991	124
NAC/10	1,896	237
NAC/20	3,792	474
NAC/25	4,740	593
NAC/30	5,688	711
NAC/35	4,956	620
NAC/40	5,664	708
<i>Naval Gauss</i>		
Light N-Gauss	3,024	378
Medium N-Gauss	5,040	630
Heavy N-Gauss	6,048	756
<i>Naval Laser</i>		
SCL/1	237	—
SCL/2	354	—
SCL/3	531	—
NL/35	830	—
NL/45	1,134	—
NL/55	1,386	—
<i>Naval PPC</i>		
Light N-PPC	1,659	—
Medium N-PPC	2,268	—
Heavy N-PPC	3,780	—
<i>Sub-Capital Missiles</i>		
Piranha	670	84
Stingray	496	62
Swordfish	317	40
Manta Ray	396	50

## CLAN CAPITAL SCALE WEAPONS AND EQUIPMENT BV TABLE [ADDENDUM]

Item	Item BV	Ammo BV
<i>Naval Autocannon</i>		
NAC/10	1,896	237
NAC/20	3,792	474
NAC/25	4,740	593
NAC/30	5,688	711

NAC/35	4,956	620
NAC/40	5,664	708
<i>Naval Gauss</i>	991	124
Light N-Gauss	3,024	378
Medium N-Gauss	5,040	630
Heavy N-Gauss	6,048	756
<i>Naval Laser</i>	5,688	711
NL/35	830	—
NL/45	1,134	—
NL/55	1,386	—
<i>Naval PPC</i>	3,024	378
Light N-PPC	1,659	—
Medium N-PPC	2,268	—
Heavy N-PPC	3,780	—
<i>Sub-Capital Missiles</i>	237	—
Piranha	670	84
Stingray	496	62
Swordfish	317	40
Manta Ray	396	50
<i>Sub-Capital Missiles</i>		
Piranha	670	84
Stingray	496	62
Swordfish	317	40
Manta Ray	396	50

## CLAN WEAPONS AND EQUIPMENT BV TABLE [ADDENDUM]

Item	Item BV	Ammo BV
<i>Energy Weapons</i>		
ER Flamer	16	—
Chemical Laser (Small)	7	1
Chemical Laser (Medium)	37	5
Chemical Laser (Large)	99	12
ER Pulse Laser (Small)	36	—
ER Pulse Laser (Medium)	117	—
ER Pulse Laser (Large)	272	—
Improved Heavy Laser (Small)	19	—
Improved Heavy Laser (Medium)	93	—
Improved Heavy Laser (Large)	296	—
Laser Anti-Missile System	45†	—
<i>Ballistic Weapons</i>		
ProtoMech AC/2	34	4
ProtoMech AC/4	49	6
ProtoMech AC/8	66	8
Rotary AC/2	161	20
Rotary AC/5	345	43
Fluid Gun	6	1
Heavy Flamer	15	2

## CLAN WEAPONS AND EQUIPMENT BV TABLE [ADDENDUM] (CONT.)

Item	Item BV	Ammo BV
'Mech Mortar/1	29	4
'Mech Mortar/2	57	7
'Mech Mortar/4	86	11
'Mech Mortar/8	114	14
Vehicular Grenade Launcher	15	—
<b>Missile Weapons</b>		
Streak LRM 5	86/17	11
Streak LRM 10	173/35	22
Streak LRM 15	259/52	32
Streak LRM 20	345/69	43
<b>Artillery Weapons</b>		
Arrow IV	168	21
Long Tom	560	70
Sniper	96	12
Thumper	48	6
<b>Melee Weapons</b>		
Claws	(Dmg x 1.275)	—
ProtoMech Melee Weapon	(Dmg x 1.25)	—
Talons	(Dmg x 1)	—

Item	Item BV	Ammo BV
<b>Other Equipment</b>		
Actuator Enhancement System	G	—
Angel ECM Suite	100†	—
Armored Components	J	—
Artemis V FCS	L	—
CASE II	H	—
MASS	9	—
Minesweeper	30†	—
Watchdog CEWS	K	—
VTOL Mast Mount	M	—

† Defensive BV

**G Actuator Enhancement System:** Multiply by 1.5 the BV of all weapons linked to the AES. Do not include the BV of ammo when calculating this sum.

**H CASE II:** Though these items are used when calculating the Defensive Battle Rating, they have no individual BV.

**J Armored Components:**

The Defensive Battle Rating of an armored component is equal to 5 percent of the BV of the item protected per slot. If the item has no BV, then the cost is 5 points per slot.

**K Watchdog CEWS:** Offensive BV 7, Defensive BV 61

**L Artemis V FCS:** Increase by 30 percent the BV of any missile launcher equipped with Artemis V.

**M Weapon Array:** BV is the BV of all the weapons on the array (but not the ammunition) x 0.1.

**N Weapon Array:** Add 10 to the BV of mast mounted weapons and equipment.

## AEROSPACE WEAPONS AND EQUIPMENT BV TABLE [ADDENDUM]

Item	Item BV	Ammo BV
<b>External Stores</b>		
AAA Missile	—	57 each
AS Missile	—	114 each
ASEW Missile	—	75 each
Arrow IV Non-Homing Missile	—	34 each
Inferno Bomb	—	16 each
LAA Missile	—	17 each
Thunder Bomb	—	*
Torpedo Bomb	—	10 each

\*Thunder Bomb has a BV equal to seven 20-point minefield of the appropriate type of mine.

## MINEFIELD BV TABLE

Type	BV per 5 Points	BV per Hex
Active Mine	6	—
Command Detonated	6	—
EMP	—	45
Inferno	5	—
Space	5	—
Standard	4	—
Vibrabomb	5	—
Tear Gas	3	—

INTRODUCTION

ADVANCED  
GROUND MOVEMENT

ADVANCED  
COMBAT

ADVANCED  
BUILDINGS

ADVANCED  
SUPPORT  
VEHICLES

GENERAL  
RULES

ADVANCED  
SUPPORT VEHICLE  
CONSTRUCTION

ADVANCED  
WEAPONS  
AND EQUIPMENT

INDEX

RECORD SHEETS

# CONSTRUCTING A BATTLE FORCE [ADDENDUM]

The following rules are intended to augment the rules for adjusting the Battle Value of a battle force (see p. 314, *TM*). As before, the BV of each unit is adjusted to take into account additional factors such as special equipment, troop quality, and force size.

## ALTERNATIVE MUNITIONS (NEW)

Some alternative munitions require the base BV of a unit carrying it to be increased before any other modifiers are applied. Consult the Alternative Munitions Table to find the modifier to the ammunition's base Battle Value. One-shot weapons (such as vehicular grenade launchers) use the BV of their launcher rather than of the ammunition.

### ALTERNATIVE MUNITIONS TABLE

Type	BV Modifier*
<i>Autocannon Munitions</i>	
Caseless	1.0
Tracer	0.25
<i>Artillery</i>	
Thunder/FASCAM	†
<i>Flamer/Fluid Gun/Sprayer Ammunition</i>	
Corrosive	2.0
Inferno Fuel	2.0
<i>Grenade Launcher</i>	
Incendiary Grenades	0.5
<i>Missile Munitions</i>	
Acid	1.0
Anti-Radiation	0.3
Follow-the-Leader Missiles	0.5
Heat-Seeking	0.5
Magnetic Pulse	1.0
Swarm-I	0.2
Tandem-Charge	1.0
Thunder/FASCAM	†
<i>'Mech Mortar Munitions</i>	
Armor Piercing	0.2

\*Multiplier is applied to each ton of ammunition to find the additional base BV value for the ammunition. For single-shot weapons the modifier is applied to the weapon itself.

†Calculate the BV by finding the total points of mines per ton, then dividing by 5. Multiply the result by the BV given on the Minefield BV Table (p. 385).

## TARGET ACQUISITION GEAR (EXPANDED)

When used in conjunction with TAG, certain equipment will increase the base Battle Value of units in a battle force. If any unit in the battle force is equipped with TAG, Light TAG, or a C<sup>3</sup> Master Computer, add BV equal to the BV (as listed in the Equipment BV Tables) for each ton Arrow IV Homing artillery missiles, Copperhead Artillery ammunition, Semi-guided LRM ammunition, or Semi-guided Mortar ammunition:-

## COMMAND, CONTROL, AND COMMUNICATIONS (EXPANDED)

Two or more units in a battle force equipped with C<sup>3</sup> systems can be designated as part of a C<sup>3</sup> network (see p. 131, *TM*). Add 5 percent to the total BV of all units in a C<sup>3</sup> network to each of the units linked by each network.

Boosted C<sup>3</sup> networks add 7 percent to the total BV of all units in a C<sup>3</sup> network.

## EXTERNAL STORES (EXPANDED)

Tactical Operations introduces a number of new types of external stores from which players can choose. See the Aerospace Weapons and Equipment Table [Addendum] for their BV values.

## SKILL RATINGS (EXPANDED)

After applying modifiers to the base BV for alternative ammunition, TAG, C<sup>3</sup>, and External Stores, adjust the BV value to reflect the skill levels of the units. (See p. 314, *TM*.)

**Cockpits:** To reflect the general impact of the control systems, units with a Small Cockpit reduce their Battle Values by a flat 5 percent.

**Drones:** Use the piloting and gunnery skill of drone's operator before adjustments for operating the unit as a drone are made.

## FORCE SIZE

Finally, the battle force BV is adjusted for the relative sizes of the opposing forces. (See p. 314, *TM*.)

## MINEFIELDS (NEW)

Potentially a battle force may start the game with one or more minefields in place. See the Minefield BV Table (see p. 385) for the BV for the different types of minefields available. The BV for any deployed mines is added after all other calculations. Minefields are not included in the unit count when adjusting the BV for the relative sizes to each force.



• A •

Abandoned units, 196-98, 216-17  
Acceleration, 24  
Accidental falls from above, 154  
  large airship support vehicles, 164  
  mobile structure, 173  
Accidental fires, 43  
Acid (AX) missiles, 367  
Active minefield, 208, 209-10  
Active mines (land), 364  
Active probes, 219  
Active probes, 99, 102, 278  
Active sensors, 219  
Actuator damage  
  braced limb, 84  
  climbing and, 22  
Actuator Enhancement System, 278, 279, 380  
Advanced maneuvers, vehicles, 25-26  
Advanced Rules Record Sheets, 11-13  
Aerospace fighters, PPCs and, 103  
Aerospace unit  
  atmospheric pressure, 55  
  critical hits, 75  
  gale, 61  
  grappling, 200  
  on ground mapsheets, 185-86  
  infantry vs. infantry actions, 199-200  
  landing/lifting off, 209  
  missed shots, 82  
  rearming, 214  
  rolling maps, 215  
  storm, 61  
  tornado, 62  
Aerospace weapons, equipment battle value table, 385  
Aimed shots, building damage, 120  
Airborne infantry, suppressing fire and, 87  
Airborne targeting, 180-81  
Airborne vehicle, picking up, 96  
Airstrike mortars, 373  
Air-defense arrow missiles, 353  
Air mobile structure  
  carrying units, 170  
  collisions, 167  
  line of sight and, 171  
  movement, 165  
Airship  
  atmospheric pressure, 54  
  gale, 61  
  hail, 57  
  heavy industrial zones and, 31  
  storm, 61  
  template table, 241  
  tornado, 62  
  zip lines, 219  
Airship support vehicle, 249  
Air-to-air arrow (AAA) missiles, 357  
Air-to-ground attacks, shielding, 20  
Altered energy weapon damage, 83-84  
Alternative munitions, 352, 386  
Altitude bombing scatter, 178  
Ammunition, 102  
  advanced support vehicles, 254, 255  
  building damage, 120  
  engine explosion, 78  
  fractional accounting, 377  
  large naval vessel damage, 159  
  mobile structure hits, 172  
  Angel ECM suite, 102, 278, 279  
  Anti-aircraft specialists, 193  
  Anti-Mech  
  skill rolls, 108  
  -trained infantry, 217  
  Anti-missile systems, 99-100  
  Anti-personnel (AP) mortars, 373-74  
  Anti-radiation (ARAD) missiles, 368  
  Anti-ship (AS)  
  missiles, 358  
  electronic warfare (ASEW) missiles, 358  
Area-effect weapon  
  combat damage, 66  
  construction factor, 122  
  engine explosion, 78  
  fires and, 45  
  large naval vessels, 159  
  minefields, 207  
  rail support vehicle damage, 153  
  shielding, 20  
Armor, 279-82  
  advanced conventional infantry, 12  
  advanced support vehicles, 252-54  
  building, 130-31  
  conditions, 219  
  fractional accounting, 376

mobile structure, 171, 266  
  piercing mortars, 374  
  tables, 253, 280  
  type modifier table, 380  
Armor diagram  
  advanced ground vehicle, VTOL, 12  
  large naval vehicle, 10  
  super-heavy vehicle, 13  
Armored buildings, 120, 121  
  construction factor, 122  
Armored components, 282, 283, 380  
Armored motive systems, 282, 283  
Arrow IV  
  artillery missile, 284  
  homing missiles, 353-54  
  homing missiles (air-launched version), 358-59  
  non-homing missiles, 354, 359  
Artemis V Fire-Control Systems, 282, 283  
Artillery, 179-86, 284  
  cannons, 284, 285  
  clearing minefield, 211  
  conventional, 284  
  counter-battery fire, 186  
  direct-fire, 185-86  
  modifiers table, 180  
  munitions, 353-57  
  not directly in playing area, 179-80  
  ordnance table, 184  
  play sequence, 179  
  ranges table, 181  
  spotters, 181-82  
  targeting, 180-82  
Atmospheric pressure/density, 52-53, 186  
Autocannon munitions, 352-53  
Autocannon, 100, 284, 285-86  
  munitions, 352-53  
Automated weapons, building, 133  
Automatic hits, 81  
Availability, 275  
Available information, 219

• B •

Backward movement  
  expanded, 22  
  hull down, 21  
Base terrain, 29  
  types, 30-31, 36-40  
Battle armor  
  C<sup>3</sup>, 297, 298  
  detachable weapon pack, 286, 287  
  DropChute, 348, 349  
  Gale, 61  
  infantry, 108  
  mechanical jump booster, 286-87, 380  
  morale check, 211  
  myomer booster, 286, 287, 380  
  picking up, 97-98  
  picking up/throwing objects, 92  
  storm, 61  
  taser, 345-46  
  throwing, 98  
  weights, 186-87  
Battlefield wreckage, 187  
Battle force construction, 386  
BattleMech  
  full-head ejection system, 310  
  harjel system, 288  
  jump pack, 292, 293  
  mechanical jump boosters, 380  
  melee weapons, 288-92  
  motive systems, 292-93  
  partial wing, 380  
  taser, 346  
  turret, 346, 347  
  UMU system, 292, 295, 380  
Battle values, advanced, 378-79  
Bay personnel, 218  
  table, 202  
Beast-mounted infantry, 294, 295-96  
Binary laser cannon, 319  
Bipedal/Mech, 21  
Black ice, 40  
Blazer  
  armor, 282  
  cannon, 319  
Blizzard, 60  
Blocking, physical attack, 88-89  
Bloodhound active probe, 278  
Bloody Dividends, 114-147  
Blowing sand, 62  
Blue shield particle field damper, 296, 380-81  
Boarding  
  infantry vs. infantry, 199-201

non-infantry, 188-91  
Bog down rules, 62-63  
Bola Narc pods, 368  
Bomb munitions, 357-60  
Bombast laser, 102, 319, 320  
Bombing, VTOLs, 108  
Booby trap, 296-97  
Boom, 110-113  
Bootlegger, 25  
Bore sighting, 185  
Bracing, 84  
Brawlers, 193  
Bridges, 116-17, 129  
Broken morale, 212  
Cliffs, sheer, 39-40  
Building  
  basics, 128  
  classification, 114-17, 128, 129  
  collapse, 123-26, 168  
  components, 131-33  
  construction, 116, 128-33  
  design process, 128-33  
  modifier, infantry vs. infantry actions, 203  
  size, shape, 114, 116, 129  
  Record Sheet, 133  
Buildings, 30  
  advanced equipment, 133-41  
  advanced features, 119  
  armored, 121  
  artillery hits, 184  
  attacking from within, 121  
  climbing and, 22  
  combat damage, 66  
  critical damage, 120-21  
  engine explosion, 78  
  fire, 43  
  infantry scaling, 27  
  infantry vs. infantry inside, 201  
  minefields and, 207  
  mobile structure, 168, 259  
  movement damage, 65  
  moving through, 118-20  
  smoke and, 48  
  standard, 116

• C •

C<sup>3</sup> (command, control and communications), 297-99, 386  
  boosted system, 298  
  booster slave, 298  
  emergency master, 298  
  remote sensor launcher, 298, 299  
Called shots, 78-79  
Capital weapons, 256  
  ACS, 330, 331  
  gauss, 332, 333  
  laser, 332, 333  
  mobile structures, 267  
  PPC, 333, 334  
Capital-scale damage, 126  
Captured units/buildings, 207  
Careful aim, 84  
Careful movement, 63-64, 65  
Cargo bays  
  fire due to weapon attacks, 190-91  
  large naval vessel damage, 159  
  units mounted in, 161  
  weapon attacks in, 188-89  
Carrying units  
  large airship support vehicles, 164  
  large naval vessels, 156  
  mobile structures, 170  
CASE II, 159, 298, 299, 381  
Caseless autocannon ammo, 352  
Castles Brian, 117-18, 126, 129, 139  
  complexes, typical components, 141-43  
  map sample, 142  
  Record Sheet, 143  
Caustic atmosphere, 56  
Ceilings, high/low, 137  
Chaff  
  grenades, 363  
  pod, 298, 299  
Chainsaw, 31, 36  
Chain whip, 298  
Chameleon light polarization shield, 300, 381  
Charging, 20, 91, 154  
Chassis  
  base value, 240  
  design (advanced support vehicle), 238-45  
  modifications, 242  
  weight calculation, 242

Chemical lasers, 319, 320  
Chemical tank  
  explosions, 134-35  
  leaks, 135  
Civilians, marine points score, 202  
Clan  
  capital scale weapons, equipment battle value table, 384  
  rotary autocannon, 286  
  weapons, equipment battle value table, 384-85  
Class, mobile structures, 261  
Claws, 288, 289  
Clearing woods, 40  
Cliffs, sheer, 39-40  
Climbing, 22, 27, 118  
Cluster weapons  
  artillery/arrow missiles, 354  
  combat damage, 66  
  hit penalties, 84  
  hits weapons, 82  
Coal-burning generators, 135  
Cockpit  
  command console, 300, 301  
  critical damage, 75  
  skill ratings, 386  
  systems, 300-301  
Cockpit systems – torso-mounted  
  cockpit, 381  
Collapsible command module (CCM), 300, 301-2  
Collision  
  large naval vessel, 155-56  
  mobile structures, 167-68  
  rail support vehicle, 149  
Combat, 74  
  damage, 66  
  general rules, 74-79  
  heat, 104-6  
  infantry, 108  
  large airship support vehicles, 164  
  large naval vessels, 157-59  
  mobile structures, 167, 171-72  
  physical, 88-91  
  picking up/throwing objects, 92-99  
  planetary conditions, 28  
  rail support vehicle, 153  
  vehicles, 107-8  
  weapon attacks, 79-88  
  weapon resolution dice, 109-10  
  weapons, equipment, 99-104  
Combat vehicle  
  chassis modifications, 302-3, 381  
  escape pod, 309  
  fission engines, 306, 307  
  fuel cell engines, 306, 307  
Combine, 38-39  
Combined minefields, 210  
Command console, 102  
  satellite, 194  
Commanders, 191-92  
  abilities, 192  
  anti-aircraft specialists, 193  
  banking initiative, 192  
  brawlers, 193  
  communications disruption, 193  
  double-blind rules, 224  
  forcing initiative, 192  
  ground attack specialists, 193  
  multiple abilities in lance, 192  
  off-map movement, 192  
  overrun combat, 193  
  sharp shooters, 193  
  zone of control, 193  
Command-detonated mines (land/sea), 208, 209, 365  
Command-level (tactical) comms, 191-96  
Communications disruption, 193  
Communications equipment, 100-101, 102  
  double-blind rules, 224  
  satellite, 194-95  
Compact heat sinks, 316  
Complexes, 128, 129, 133  
Components, 10  
Composite structure, 342  
Concealing information, 219-20  
  active probes, 99  
Construction, 10  
  advanced options, 376-78  
  construction factor, 121-23, 128, 129  
  armor, structure, 11  
  Castles Brian, 139  
  climbing and, 118  
  damage, 204  
  expanded, 45  
  gale, 61

meteor showers, 56  
  mobile structures, 261  
  storm, 61  
  tornado, 62  
Construction rules, 275  
  advanced equipment, 136  
Control systems, 249-51  
Conventional Infantry Record Sheet, Advanced, 12  
Coolant ammo, 361  
Coolant pod, 303-4, 381  
Copperhead artillery, 355  
Corrosive ammo, 361  
Counter-battery fire, 186  
Cover  
  non-infantry units as, 108  
  partial, 87-88  
Crashing  
  airborne unit, clearing minefield, 211  
  airborne unit, minefield, 209  
  battlefield wreckage, 187  
  ice, 50  
Crawling, 20  
Creature size table, 294  
Crew  
  accommodations, 250  
  accommodations, mobile structures, 265  
  advanced support vehicle minimum tables, 250  
  data, advanced ground vehicle, VTOL, 12  
  data, structure, 11  
  hits, 206  
  killed, large naval vessel damage, 159  
  losses/casualties, 206  
  marine points score, 201-2  
  numbers, abilities, 218-19  
  quarters, 131, 256, 268  
  support vehicle, 249-5  
  systems, 131-33  
  table, 132  
  transport bays, 218  
Critical damage, 74-75  
  buildings, 120-21  
  cockpit, 75, 76  
  direct-fire ballistic, artillery weapons, 76  
  direct-fire energy/pulse weapons, 75  
  equipment, 76  
  large naval vehicle record, 10  
  large naval vessels, 159  
  missile weapons, 76  
  satellite, 11  
Critical hits, 74-75  
  advanced/Mech table, 12  
  advanced VTOL table, 12  
  buildings, 120-21  
  floating rule, 77  
  mobile structures, 172  
  Cruise missile, 186  
  artillery, 284-85  
  attack, morale checks and, 211  
Crush depth checks, 42, 43

• D •

Damage  
  artillery, 182-84  
  building, 122-23  
  keeping secret, 75  
  order of, 66  
  order of, building collapse, 123  
  piloting skill roles, 23-24  
  scaled, 124  
  scaled, armored buildings, 121  
  threshold, buildings, 120  
  tracking, mobile structure, 167-68, 172  
  weapon attacks, 83-84  
Dangle-and-drop, 22  
Data, structure, 11  
Dawn, 58  
Dead zones, 79-80, 83  
Death from above, 91  
Deceleration, 24-25  
Deep snow, 41  
Defensive factors modifier, 379  
Demolition engineers, 341  
Derailment  
  damaged rail support vehicles, 153  
  rail support vehicles, 149-50, 151  
Destroyed gyro, 20

INTRODUCTION

ADVANCED GROUND MOVEMENT

ADVANCED COMBAT

ADVANCED BUILDINGS

ADVANCED SUPPORT VEHICLES

GENERAL RULES

ADVANCED SUPPORT VEHICLE CONSTRUCTION

ADVANCED WEAPONS AND EQUIPMENT

INDEX

RECORD SHEETS



Destruction  
 mobile structures, 172  
 rail support vehicle, 151-52  
 sinking vessel, 161  
 DFA, 20  
 Digging in, 108  
 Direct blow, 81  
 Direct-fire artillery, 185-86  
 Dirt road, 51  
 Dismounting  
 units in cargo bay, 161  
 units on sinking vessel deck, 160  
 Displacement, 63  
 building, 122-23  
 mobile structure, 173  
 Disposable weapons, 304  
 Dive equipment, 249  
 Docking  
 collar, 304  
 hardpoint, 304  
 thrusters, 304, 205  
 Domino effect, 124  
 Doors, large, 138  
 Double-blind rules, 220-25  
 Turn Record Sheet, 13  
 Dragging/Mech, 99  
 Drone  
 carrier control systems, 304, 305  
 operating system, 306  
 skill ratings, 386  
 systems, 305-6  
 DropShips  
 fire effect on, 45  
 mobile structures and, 167, 168  
 movement damage, 65  
 non-infantry boarding, 188-91  
 swamp, 51  
 Dune buggy, 302, 303  
 Dusk, 58

• E •

Earthquake, 55  
 ECCM, 100-101, 102  
 double-blind rules, 224-25  
 ECM suites, 100-102  
 active probes, 99  
 double-blind rules, 224-25  
 modifier table, 223  
 Efficiency of Rome, 270-273  
 Ejection, 196-98  
 modifiers table, 197  
 systems, 309-10  
 Electromagnetic interference (EMI), 55  
 Electromagnetic pulse (EMP) mines (land), 208, 365  
 effects table, 365  
 Electronic countermeasures (ECMs), satellites, 195-96  
 Electronic equipment  
 critical damage, 75  
 ejection, abandoned unit, 196  
 large airship support vehicles, 164  
 large naval vessel, 159  
 taking control of, 216  
 Electronic warfare (EW) equipment, 310-11  
 Endo-composite structure, 342  
 Enemy vehicle, picking up, 96  
 Energy storage batteries, 306  
 Energy weapons, 102  
 Engine  
 base value, 240  
 explosions, 77-78  
 fractional accounting, 376  
 hit, large naval vessel damage, 159  
 master table, 308  
 systems, 307-9, 381  
 tables, 246, 247  
 Enhanced long-range missile (NLRM)  
 launchers, 326-27  
 Environmental sealing, 136-37, 302, 303  
 mobile structures, 265  
 Equipment  
 advanced, 380-85  
 advanced support vehicles, 254, 255-58  
 attacking building, 121  
 battle values, 280  
 missile, 103  
 mobile structures, 266-69  
 space limits, 240  
 unspecified, 131  
 ER pulse lasers, 320  
 Eruptions, hazardous liquid pools, 49  
 Evading, 18-19  
 Expanded movement cost, planetary conditions, 28-30, 32-36

Explosions, unintended, 31  
 Extended long-range missile (ELRM)  
 launchers, 327  
 Extended-range flamer, 312  
 External stores, 386  
 Extreme depths, 42-43  
 Extreme range, 85  
 Extreme temperature, 58, 60, 62  
 (cold) troops, 350, 351  
 (hot) troops, 350, 351

• F •

Facing, mobile structures, 167  
 Falling, 91  
 bog down rules, 62  
 damage, 65  
 expanded, 24  
 gravity damage, 55  
 intentional, 91  
 minefield, 209  
 FASCAM  
 artillery/arrow missiles, 357  
 bombs, 360  
 Fatigue, 198  
 Fences, 116, 129  
 Ferro-Lamellor armor, 279-80  
 Fiction  
 art and, 10  
 rules and, 9  
 Field artillery, 310, 311  
 Field guns, 310, 311  
 Fighters, picking up, 96  
 Fire  
 cargo bay due to weapon attacks, 190-91  
 deep snow, 41  
 effects of, 43-45  
 heavy industrial zones and, 31  
 ice, 50  
 putting out, 45  
 smoke, 45-46  
 smoke resolution sequence, 46-47  
 spreading, 45  
 tables, 44  
 thin snow, 52  
 Fire control systems, 250-51, 256  
 mobile structure, 265, 267  
 Firefighting engineers, 341  
 Firing arcs, 107  
 mobile structure, 267  
 Firing stances, 84  
 Fishtail, vehicle, 26  
 Flail, 288, 289  
 Flak, 185-86  
 autocannon ammo, 352  
 Flamer ammunition, 360-63  
 Flame-retardant foam ammo, 361  
 Flamers, 312  
 Flammable atmosphere, 56  
 Flanking, gravity damage, 55  
 Flare mortars, 374  
 Flechette artillery, 355  
 Flight deck, 312, 313  
 large airship support vehicles, 164  
 large naval vessels, 156  
 mobile structures, 170

Flipping  
 arms, 87  
 over, 26-27  
 Flotation hull, 302  
 Fluid gun, 312, 313  
 ammunition, 360-63  
 Fog, 57  
 Foliage, level 1, 36  
 Follow-the-leader (FTL) missiles, 368  
 Force size, 386  
 Forced withdrawal, 213  
 Force size, 386  
 Forms, 9  
 Fortresses, 117, 137, 260  
 Four-legged Mech  
 earthquake, 55  
 hit location table, 77  
 picking up/throwing, 92  
 Record Sheets, advanced, 12  
 shielding, 19  
 Fractional accounting, 376-77  
 Fragmentation grenades, 363  
 Friendly vehicle, picking up, 96  
 Fuel capacity, 248-49  
 mobile structures, 263-64  
 Fuel storage, 264  
 Fuel tank leak/explosion table, 136  
 Full-head ejection system, 310  
 Fully amphibious option, 302, 303

Full moon night, 58  
 Fumble, 23, 75, 77

• G •

Gale (light, moderate, strong), 60  
 Game  
 rules, 275  
 running, 220  
 Gauss  
 rifles, 313-15  
 weapon rearming, 214  
 weapons, 102  
 Generator fuel, 134, 135  
 Geysers, 48  
 Ghost targets, 101-2  
 Glancing blow, 70-73  
 Glancing/direct blows, 19, 80  
 Glare, 58  
 Grabbing, 90  
 Grappling, 90  
 aerospace units, 199  
 attacking unit, 199-200  
 infantry, 200  
 large naval vessels, 200  
 mobile structures, 201  
 small craft, 200  
 units, 96  
 Grav deck, 314, 315  
 Gravel piles, 30-31  
 Gravel road, 51  
 Gravity  
 artillery, 186  
 high/low, 55  
 rating, 43  
 Grenade launcher  
 munitions, 363-64  
 vehicular (VGL), 314, 315  
 Ground attack specialists, 193  
 Ground combat vehicle hit location, 107  
 Ground mobile structure  
 collisions, 167  
 stacking, 168-70  
 Ground units, critical hits, 75  
 Ground Vehicle Record Sheets, advanced, 12  
 Gun emplacements, 117, 137  
 Gunners  
 killed, 120  
 killed, mobile structure, 172  
 stunned, 120  
 stunned, mobile structure, 172  
 Gusting rain, 59

• H •

HAG, 84  
 Hail, 57-58  
 Half levels, 31  
 Handheld weapons, 314, 315-16, 381  
 Hangar, 116, 137, 259  
 Hardened armor, 280, 281, 380  
 Harpoon missiles, 369  
 Hazardous liquid  
 environment troops, 350, 351  
 pools, 49-50  
 Head location destruction, 197  
 Heat  
 avoiding shutdown, 104  
 condition, 219  
 coolant systems, 105-6  
 data/scale, advanced Mech, 12  
 deep snow, 41  
 expanded scale, 104  
 full moon night/glare, 58  
 heat sink coolant failure, 105-6  
 light and, 58  
 point table, 63  
 rerouting heat sink coolant, 105  
 scale modifiers, 64  
 Heat-seeking (HS) missiles, 369  
 Heat sinks, 251-52, 255, 316-17  
 coolant failure, 105-6  
 mobile structures, 267  
 table, 253  
 Heavy flamer, 312  
 Heavy industrial zone, 31  
 Heavy rainfall, 59  
 Heavy snowfall, 60  
 Helipad, 312, 313  
 Hex  
 conditions, terrain displacement, 57  
 destruction, mobile structure, 172  
 Hidden units, 220  
 active probes, 99  
 High-altitude maps, 185  
 High-resolution imager, 338, 339

Hit location  
 advanced VTOL, 12  
 ground combat vehicle, 107  
 Hits determination, artillery, 182  
 Hitting deck, 108  
 Homing missiles, 181  
 Hostile units, carrying, 94  
 Hot zone, 218  
 Hover vehicle  
 atmospheric pressure, 54  
 careful movement, 64  
 gale, 61  
 mobile structure, 173  
 mud, 50  
 storm, 61  
 swamp, 51  
 tornado, 62  
 Hull down, 21  
 Hull integrity, atmospheric pressure, 54  
 Hurried movement, 20-21  
 Hyperspectral imager, 338, 339  
 Hyper-velocity autocannon (HVAC), 285

• I •

Ice, 50  
 breaking through, 50  
 storm, 60  
 Illumination artillery/arrow missiles, 355  
 Immobile targets, 149  
 Improved heavy gauss rifle, 312, 313-14  
 Improved heavy lasers, 321  
 Improved one-shot (I-OS) missile  
 launchers, 327  
 Improved position, 198-99  
 Inanimate objects  
 carrying, 94  
 dropping, setting down, 98  
 picking up, 92-93  
 throwing, 94-95  
 Incendiary  
 grenades, 364  
 LRMs, 369-70  
 Indirect artillery  
 fire, 179  
 flight times table, 181  
 Indirect fire, 185  
 Industrial elevators, 137-38  
 IndustrialMechs, extreme depths and, 43  
 Infantry  
 advanced battle values, 379  
 armor, 317-18  
 atmospheric pressure, 54  
 attacks against large formations, 84  
 bog down rules, 63  
 carried externally, 153  
 combat, 108  
 digging in, 108  
 direct blow, 81  
 extreme temperature, 62  
 fatigue, 198  
 fire effects on, 43-45  
 gale, 61  
 glancing blow, 80  
 grappling, 200, 201  
 gravel piles and, 31  
 hail, 57  
 hazardous liquid pools, 49  
 ice, 50  
 light rainfall, 59  
 light snowfall, 60  
 minefield, 207  
 morale check, 211  
 movement, 27  
 movement damage, 65  
 opportunity fire, 86  
 rail support vehicles and, 149, 153  
 sheer cliffs movement, 39  
 shielding, 19  
 sinking naval vessel and, 161  
 squad deployment, 108  
 stealth modifiers table, 318  
 storm, 61  
 taking control of abandoned units, 216-17  
 terrain displacement, 66  
 thin snow, 52  
 tornado, 62  
 with UMU MP, 160, 161  
 zone of control, 193  
 Infantry vs. infantry action  
 attacker vs. defender ratios, 204  
 boarding, 199-201  
 building modifier, 203  
 captured units/buildings, 207  
 crew losses/hits, 206  
 inside building, 201

large-scale, 203  
 resolving, 201-5  
 roll, 204  
 table, 205  
 Inferno  
 bombs, 359  
 fuel ammo, 361-62  
 -IV missiles, 356  
 mines (land/sea), 366  
 morale checks and, 211  
 Infrared  
 imager, 339  
 sensors, 223  
 Initiative  
 aerospace units, 200  
 banking, 192  
 double-blind rules, 221-25  
 forcing, 192  
 Inner Sphere  
 capital scale weapons, equipment  
 battle values, 384  
 weapons, equipment battle values, 382-83  
 Intentional fires, 43  
 Internal structure  
 damage, 204  
 integrity values, 242-44  
 weight for, 242-45  
 Internal weight capacity, building, 129  
 Interstellar operations, 9  
 Into the fire, 174-177  
 I-Swarm, 81

• J •

Jumping  
 bog down rules, 62  
 capability, 249  
 gravity damage, 55  
 ice, 50  
 Mechs, opportunity fire, 86  
 vibrabomb minefield and, 209  
 Jump jet attack, 90-91  
 Jungle, 31

• L •

Lake  
 hazardous liquid pools and, 49  
 water flow, 52  
 Lance, 288, 290  
 movement, 24  
 Landing aerospace unit, clearing minefield, 211  
 Landing deck, 318, 319  
 Large airship  
 advanced battle values, 379  
 unit design, 237, 238  
 Large airship support vehicle, 164  
 fuel, 248  
 Large craft  
 collisions, 149  
 communications equipment, 195  
 PPCs and, 103  
 taking control of, 216  
 Large engine, 307, 308  
 Large naval vessel  
 advanced battle values, 379  
 grappling, 200  
 non-infantry boarding, 188-91  
 Record Sheet, 10  
 template, 13  
 turret installation, 244  
 unit design, 237, 238  
 Large naval vessel support vehicle  
 artillery hits, 184  
 carrying units, 156  
 combat, 157-59  
 critical damage, 159  
 flight decks, 156  
 movement, 154-56  
 shielding, 19  
 stacking, 156  
 surfacing, 173  
 taking control of, 216, 217  
 tractors, 156  
 unit destruction, 159-63  
 Large vehicle/vessel  
 effectiveness, 107  
 hull down, 21  
 movement damage, 65  
 template table, 241



**Laser**  
anti-missile system, 319, 322, 381  
heat sinks, 316-17  
insulator, 322, 381  
reflective armor, 280, 281  
Laser-inhitting (LI) arrow missiles, 356  
Lasers, 319-21  
Laser-variable speed pulse, 382  
LB-X, 84  
Leaping, 22  
Leg  
damage, 24  
destruction, hull down, 21  
Leg-mounted weapons, hull down, 21  
Level change  
mobile structures, 165  
smoke and, 48  
Level difference, missed shots, 83  
Level  
artillery and, 184  
engine explosion, 78  
physical combat, 90  
Lift equipment, 249  
Light, 58-59  
Light air-to-air (LAA) missiles, 359  
Light gale, 61  
Light rainfall, 59  
Light sail, 322, 323  
Light snowfall, 60  
Lightning  
bolt table, 59  
storm, 59  
Limited amphibious, 302  
Line of sight (LOS), 79-80, 83  
chart, 13  
combat damage, 66  
large airship support vehicles, 164  
large naval vessels and, 157  
mobile structure combat, 171  
mobile structures, 165  
range, 85  
Linked weapons, 85-86  
Liquid fuel  
explosions, 134-35  
leaks, 135  
Lithium-fusion battery, 322, 323  
Long Tom, 284  
Look-down radar, 340  
Low-altitude maps, 185

• M •

Mace, 288, 290  
Machine guns, 102  
array, 102  
Magma, 36-38  
crust, 36-37  
eruptions, 37-38, 49  
liquid, 37  
Magnetic pulse (MP) missiles, 170  
expenditure, 165  
Magscan sensors, 223-24  
Magshot gauss rifle, 314  
Maneuver, 18  
failed, 26  
Map, structure, 11  
Marine points score, 201-3  
re-converting, 205-6  
tables, 202  
Marines, 341  
Mass driver, 322, 323  
Vessel limits table, 322, 232  
Mech  
atmospheric pressure, 54  
data, advanced, 12  
dragging, 99  
drop pack, 292, 293  
ejection, abandonment, 196-97  
engine type modifier, 381  
full-head ejection system, 197  
gale, 61  
heavy industrial zone, 31  
hit location table, advanced, 76, 77  
ice, 50  
internal structure modifier table, 382  
level 1 foliage, 36  
limbs, tearing off, 93  
mortar, 324  
mortar ammunition, 373-75  
mounting large naval vessels, 157  
mud, 50  
Record Sheets, advanced, 12  
rerouting heat sink coolant, 105  
satellite uplinks, 194  
on sinking vessel, 160, 161  
sheer cliffs movement, 39  
storm, 61

swamp, 51  
terrain displacement, 66  
throwing, 95-96  
tornado, 62  
Mechanical jump boosters, 292, 293  
Mechanized infantry, digging in, 108  
Mechanized VTOL infantry, 324  
MechWarrior Aquatic Survival System (MASS), 324, 325  
Meteor showers, 56  
Micro-Copter VTOL platoons, 324  
Microlite VTOL platoons, 324  
Mine, 364-67  
clearance missiles, 370  
clearing, 103  
dispensars, 324, 325-26  
Minefield, 207-8, 386  
active probes, 99  
battle value table, 385  
clearing, 210-11  
combined, 210  
conventional, 208-9  
density table, 208  
types of, 207  
weapon-delivered, 210  
Minesweepers, 211, 326  
Minesweeping engineers, 209, 211, 341  
Missed shots, 81-83  
buildings, 121  
Missile, 102-3  
Clearing minefield, 211  
launchers, 326-27  
munitions, 367-73  
Mixed technologies, 377  
Mobile field base, 330  
Mobile hyperpulse generators, 330, 331  
Mobile structure, 10, 128, 143  
advanced battle values, 379  
armor, 171, 266  
artillery hits, 184  
buildings, 168  
carrying units, 170  
charging, 154  
clearing minefield, 211  
collisions, 167-68  
combat, 171-72  
crew, 264-65  
critical hits, 172  
damage threshold, 171  
design, 259-61  
destroying, 172  
equipment, 266-69  
fire effects on, 45  
flight decks, 170  
fuel capacity, 263-64  
heat sinks, 267  
ice, 50  
minefield, 209  
morale, 211  
motive systems, 262, 263  
movement, 165-67  
movement costs table, 156  
movement damage, 65  
mud, 50  
power systems, 262, 263  
Record Sheet, 269  
special enhancements, 265-66  
stacking, 168-70  
swamp, 51  
template, 13, 165  
type, 259-60  
underneath, 209  
unit design, 237  
unit displacement, 173  
weapons, 266-67  
Moderate gale, 61  
Moderate rainfall, 59  
Moderate snowfall, 60  
Modular armor, 281, 380  
Modular structure  
linkage, 265  
power and motive, 264  
Modular technology, 275  
Moonless night, 58  
Morale  
broken, 212  
checks, 211-12  
recovering nerve, 213  
tables, 212  
Motive system  
Damage, 107  
damage table, 21  
mobile structures, 262, 263  
Mountain troops, 27, 341  
Mounting through bay door, 188  
Movement  
damage, terrain factor, 65  
dice, tips, suggestions, 27-28

effects, gravity, 55  
infantry, 27  
large airship support vehicles, 164  
large naval vessel support vehicles, 154-56  
mobile structures, 165-67  
modes, 18-20  
phase, double-blind rules, 221-25  
rail support vehicle, 149-50  
record, 215  
satellites, 148-49  
vehicles, 24-27  
M-Pod, 330, 331  
MRM "Apollo" fire control system, 330, 331  
Mud, 50  
heavy rainfall, 59  
moderate rainfall, 59  
torrential downpour, 59  
Multi-hex  
building collapse, 122, 123  
items, 268  
support vehicles, fire effects on, 44-45  
units, weight of, 240  
Multi-level bridges, 117  
Multiple buildings, 133  
Multiple targets, autocannon, 100

• N •

Naval  
autocannons, 330, 331  
C1, 332  
Comm-Scanner Suite, 332, 333  
gauss, 332, 333  
laser, 332, 333  
PPC, 333, 334  
repair facilities, 334  
support vehicle fuel, 248  
tractors, 156  
tug adaptor, 334, 335  
units, sinking naval vessel and, 161  
vessels, abandonment, 197-98  
Non-airborne units, terrain displacement, 66  
Non-DropShip aerospace units movement damage, 65  
mud, 50  
swamp, 51  
Non-hover ground vehicles, ice, 50  
Non-infantry, morale check, 211  
Non-liquid fuels, 136  
Non-Mech units, tornado, 62  
Non-mobile structure surfacing, 173  
Non-spheroid aerospace unit atmospheric pressure, 54  
ice, 50  
gravel piles and, 31  
heavy industrial zones and, 31  
magma and, 37  
Null-signature system, 336, 382

• O •

Obscured ammo, 362  
Off-map movement  
commanders, 192  
mobile structures, 167  
Oil slick ammo, 362  
OmniVehicle  
airship structural integrity, 249  
armor, 252-53  
chassis in advanced support, 244  
crew/control systems, 251  
design, 237  
engine in advanced support, 247  
fuel in advanced support, 248  
heat sinks, 252  
Record Sheet, 258  
technology, 275  
weapons, equipment, 255-56  
Open-space construction, 138-39  
Opportunity fire, 86-87  
Overcharging, PPC, 103-4  
Overdrive, 25  
Overrun forces, 193

• P •

Paint/obscured ammo, 362  
Paramedics, 340, 341  
Paratroops, 341  
Partial cover, 36, 87-88  
Partial wings, 292, 293, 295  
Particle projector cannon (PPC), 103-4  
capacitor, 336, 337, 382  
feedback table, 103  
overcharging, 103-4  
Passenger quarters, 131  
Patchwork armor, 377-78, 382  
Pavement, infantry movement on, 27  
Physical attacks  
opportunity fire, 87  
simultaneous movement and, 216  
Physical combat  
addendum table, 89  
attack types, 88-91  
charging, 91  
death from above, 91  
intentional falls from above, 91  
new weapons, 88  
weight class modifiers, 88  
Physical defense, 20  
Physical weapon, 89  
dropping, setting down, 98  
picking up, 92-93  
throwing, 95  
Picking up  
battle armor, 97-98  
inanimate objects, 92-95  
/throwing objects, 92-99  
vehicles, 96-97  
Piloting skill rolls, 23-24  
Pilots, transport bays, 218  
Pintles, 255, 267  
Pitch black, 58  
Planetary conditions, 28  
artillery, 181, 186  
assigning, 29  
climbing and, 22  
units, sinking naval vessel and, 161  
conflicting, 29-30, 68  
expanded movement cost, 28-30, 32-36  
mapsheets table, 68  
mobile structures, 165  
tables, 69  
Planted fields, 38-39  
Plasma weapon rearming, 214  
Player adjudication, 9, 165  
Play sequence, 220-21  
Plotting movement, 215  
Pointblank attacks, 185  
Poisonous atmosphere, 56  
"Popping up," opportunity fire and, 87  
Power amplifiers, 131, 255  
mobile structures, 267  
Power collector and microwave transmitter, 336, 337  
Power generators  
building, 133-34  
table, 134  
Power systems, 131  
mobile structures, 262, 263  
Pre-designed hexes, artillery, 180  
Pre-determining satellite, 194  
Pre-generated maps, 128  
Prone, 21  
Prone/Mech  
firing, 85  
hit location table, 77  
ProtoMech  
atmospheric pressure, 54  
autocannons, 286  
bog down rules, 63  
bracing, 84  
ejection, 196  
extreme temperature, 62  
fire effects on, 43  
gravity damage, 55  
hurried movement, 20  
melee weapon, 336, 337  
motive systems, 292-93  
partial wing, 380  
picking up/throwing objects, 92  
shielding, 19  
terrain displacement, 66  
throwing, 95-96  
Pulse, 84  
Punch attack, 96

• Q •

Quantity-limited items, 268  
Quicksand, 51

• R •

Radiological atmosphere, 56  
Radius diagram, 183  
Rail, 51  
shielding, 19  
systems, 10  
Rail support vehicle, 51, 149-54  
accidental falls from above, 154  
advanced battle values, 378  
carrying units, 150-52  
charging, 154  
chassis design, 238  
collisions, 149  
combat, 153  
fuel, 248  
movement, 149-50  
unit design, 237  
weight and, 237-38  
Rainfall (light, moderate, strong), 59  
Range  
modifier, advanced conventional infantry, 12  
extreme, 85  
Rapid-fire mode, 84  
autocannon, 100  
machine guns, 102  
Rapids, 50, 59  
Reactive armor, 282  
Rearming under fire, 213-14  
Recon camera, 336, 337-38  
Record Sheet, 10-13  
building, 133  
concealing, 219  
mobile structures, 269  
support vehicle design, 258  
Recovering nerve, 213  
Reflec/glazed armor, 280, 281  
Reinforced repair facilities, 334, 335  
Reinforced structure, 342, 343  
Reinforcements, outside, 204  
Remote sensors, 374, 375  
double-blind rules, 224  
monitor table, 375  
Remote systems, 305-6  
Retractable blade, 104  
Reverse gear, 25  
Reversing arms, 87, 88  
Rifle (cannon), 338  
River  
hazardous liquid pools and, 49  
water flow, 52  
Roads, 51  
Rolling maps, 214-15  
artillery, 179-80  
Rough terrain, 39  
Rubble, 39  
Rules  
choosing, 9  
level, 275  
Running, gravity damage, 55  
Running around, 154  
large naval vessel, 160

Sabotage, 207  
Sand, 39  
Satellite, 10, 148-49, 193  
advanced battle values, 378  
communications equipment, 194-96  
double-blind rules, 224  
imagers, 195, 338-40  
Record Sheet, 11  
support vehicle fuel, 248  
support vehicle weight, 237  
type table, 195  
unit design, 236-37  
uplink establishment, 194  
Scaled damage, building, 123, 124, 126-27  
Scanning, 219-20  
Scatter, 178-79, 182  
SCUBA  
(motorized), 341  
(standard), 341  
Searchlights, 57, 58, 59  
Seismic sensors, 222-23  
Self-destruct sequence, 78  
Semi-guided mortars, 374  
Semi-subsurface structures, 140-41  
Sensor  
active, 219  
engineers, 341  
range tables, 222  
spotting, 221-22  
standard, 219-20

INTRODUCTION

ADVANCED  
GROUND MOVEMENT

ADVANCED  
COMBAT

ADVANCED  
BUILDINGS

ADVANCED  
SUPPORT  
VEHICLES

GENERAL  
RULES

ADVANCED  
SUPPORT VEHICLE  
CONSTRUCTION

ADVANCED  
WEAPONS  
AND EQUIPMENT

INDEX

RECORD SHEETS



Set-up, concealing, 219  
Shape, mobile structures, 261  
Sharp shooters, 193  
Sheer cliffs, 39-40  
Shield, 19-20, 89-90, 288, 291, 382  
Sideslip, 25  
Silver bullet gauss rifle, 314-15  
Simultaneous movement, 215-16, 220  
  Record Sheet, 13  
Sinking  
  hex destroyed, 161  
  rate, large naval vessel, 159, 160  
  ship diagram, example, 162-63  
Size, mobile structures, 261  
Skidding, 23  
  bog down rules, 63  
  vehicle, 26  
Skilled evading, 19  
Skill ratings, 386  
Skills, advanced conventional infantry, 12  
Sleet, 60  
Small aerospace cockpit, 300, 301  
Small buildings, 118  
Small craft  
  grappling, 200  
  swamp, 51  
Small items, mobile structure, 267  
Smoke, 45-46  
  artillery/arrow missiles, 356  
  dissipation, 48  
  drift, 47-48  
  grenades, 364  
  heavy, 47  
  light, 47  
  missiles, 371  
  mortars, 375  
  resolution sequence, 46-47  
Sniper, 284  
Snow, 60  
  deep, 41  
  flurries, 60  
  thin, 52  
Solar flare, 58  
Snowfall (light, moderate, strong) 60  
Space, 244  
  armor, 252  
  dispensers, 325-26  
  engines, 247  
  fuel, 248  
  heat sinks, 252  
  mines, 366  
  mines table, 366  
  weapons and equipment, 254  
Special enhancements, 251  
  mobile structures, 265-66  
Specialized attacks, mobile structure, 171  
Specialized infantry, 340-41  
Speed  
  declaring, 25  
  vehicles, 24-25  
Spheroid aerospace units  
  deep snow, 41  
  gravel piles, 31  
  heavy industrial zones and, 31  
  ice, 50  
  landing in planted field, 39  
  magma and, 37  
  mud, 50  
  thin snow, 52  
Spikes, 288, 291  
Splash damage, 123-24  
Spotting phase, double-blind rules, 221-25  
Sprayer, 45  
  ammunition, 360-63  
Sprinting, 18  
Squad deployment, 27  
Stacking, 216  
  expanded, 22-23  
  large airship support vehicles, 164  
  large naval vessels, 156  
  mobile structures, 168-70  
Stand  
  attempting to, 24  
  careful, 24  
Standard (conventional) mines (land/  
  sea), 366-67  
Standard repair facilities, 334, 335  
Standing still, 18  
Static buildings, 128  
Stealth  
  double-blind rules, 224  
  modifier table, 223  
Storm, 61  
Strafing, 107-8  
Strategic operations, 8-9  
Streak LRM launchers, 327  
Strong gale, 61  
Structural integrity

  damage, 204  
  values, 242-44  
  weight for, 242-45  
Structural tech rating, 242  
Structure, 342-43, 382  
  Record Sheet, 11, 110  
Sub-capital  
  cannons, 343  
  lasers, 343  
  missile critical table, 344  
  missile launchers, 344  
  weapons, 342, 343-44  
Sub-compact K-F drive system, 344  
Submarines, movement, 154  
Submerged mobile structure, 173  
Subsurface structures, 140-41  
Supercharger, 344, 345, 382  
Super-heavy vehicle, 79, 378  
  game rules, 378  
  Record Sheet, 13  
Superstructure  
  establishment, 128-30  
  heavy metal, 137  
Support vehicle (advanced), 10, 236-37  
  armor, 252-54  
  control/crew systems, 249-51  
  design, chassis, 238-45  
  design, Record Sheet, 258  
  design steps, 238  
  engine installation, 245-48  
  hazardous liquid pools, 49  
  heat sinks, 251-52  
  Record Sheet table, 239  
  structure tables, 243  
  structure values table, 244  
  types table, 239  
  weapons, ammo, equipment, 254-58  
  weight selection, 240-45  
Suppressing fire, 87  
Surface building collapses, 139  
Surfacing  
  large naval vessel support vehicle, 155,  
  173  
  mobile structure, 173  
Swamp, 51  
Swarm ammo, shielding, 20  
Swarming, 153, 217  
Swarm-LRMs, 371  
Swarm LRMs, 81, 371

## • T •

Tactical analysis, 14  
Tactical operations, 8  
Tainted atmosphere, 56-57  
Taking control of unit, 216-17  
Talons, 288, 291  
Tandem-charge (TC) missiles, 372  
Target acquisition gear, 386  
Targeting  
  active probes, 99  
  artillery, 180-82  
  shielded hex, 20  
Targeting computers, 84, 102  
Taser effects table, 346  
Taser, 344, 345  
  effects table, 346  
Tear gas SRMs, 372  
TechManual  
  mobile structures, 266  
  weapons and equipment, 254  
Technology base/rating, 128-31, 237,  
  244, 275  
  advanced support vehicles, 239  
  armor, 252  
  control/crew systems, 251  
  engine types, 247  
  fuel tanks, fuels, 264, 248  
  heat sinks, 252  
  mobile structures, 260, 265, 266  
  special enhancements, 265-66  
  table, 242  
  unit design, 237  
  weapons and equipment, 254  
Tents, 116  
Terrain  
  base, 29  
  charging, 91  
  conditions, 29, 54-57  
  damage, placement, 67-68  
  displacement, 66-68  
  effects, 31  
  geyser, 48  
  modifications, 29, 40-53  
  piloting skill modifiers, 21  
  reduction, mobile structures, 165  
Terrain factor, 21

## • U •

  battlefield wreckage, 187  
  careful movement, 64  
  conversion table, 64  
  fires and, 45  
  gale, 61  
  ice, 50  
  lightning storm, 59  
  meteor showers, 56  
  mobile structures, 167  
  movement damage, 65  
  rules, 64-68  
  storm, 61  
  tornado, 62  
Throwing  
  battle armor, 98  
  capabilities, 92  
  distance table, 92  
  objects, inanimate, 94-95  
  vehicle, 97  
Throwing 'Mechs, ProtoMechs, 95-96  
Thrust, expending, 200  
Thrusters, 149  
Thumper, 284  
Thunder  
  artillery/arrow missiles, 357  
  bombs, 360  
  LRMs, 372-73  
Thunderbolt missile launcher, 346, 347  
Time limit, plotting movement, 215  
Tonnage-based items, 267  
Top-down collapse, building, 122  
Tornado  
  F1-F3, 61-62  
  F4+, 62  
Torpedo bombs, 360  
Torrent, 52, 59  
Torrential downpour, 59  
Torso-mounted cockpit, 300, 301  
Toxic atmosphere, 56-57  
Toxic/tainted atmosphere troops, 350, 351  
Trace atmosphere, 54  
Tracer autocannon ammo, 353  
Tractor/trailer  
  detachment, 149  
  engine requirements of, 247  
Transport bay attacks, 189  
Transport bays/doors, 217-18, 256, 268-69  
Trench/fieldworks engineers, 341  
Tripping, 91  
Tundra, 40  
Tunnels, 141  
Turn modes, vehicles, 25  
Turret, 255, 347-48, 382  
  destruction, large naval vessels, 159  
  grabbing, 90  
  jam, 120  
  jam, mobile structure, 172  
  locks, 120  
  locks, mobile structure, 172  
  mobile structure, 171, 267  
  structural integrity values, 244

## • V •

Vacuum, 54  
  sealing, 302, 303  
Vacuum/trace atmosphere troops, 350, 351  
Variable speed pulse (VSP) lasers, 321  
Vehicle  
  abandonment, 197  
  atmospheric pressure, 54  
  combat, 107-8  
  crews, 103, 218-19  
  DropChute, 348, 349  
  dual turret, 347  
  effectiveness, 107  
  extreme temperature, 62  
  fire effects on, 43-44  
  gravel piles and, 31  
  hull down, 21  
  hurried movement, 20  
  jump jets, 348, 349, 382  
  minefield, 209  
  missiles, 103  
  movement, 24-27  
  sheer cliffs movement, 39  
  Sponson turret, 348  
  stealth armor, 282, 380  
Vehicle and battle armor dispensers, 325  
Vibroblast minefield, 208, 209, 367  
Vibroblades, 288, 292  
Visual inspection, 220  
Visual range tables, 221  
Visual spotting, 221  
Void-signature systems, 348, 349, 382  
Volcanic eruptions, 37-38  
VTOL vehicle  
  atmospheric pressure, 54  
  blowing sand, 62  
  chin turret, 348  
  effectiveness, 107  
  gale, 61  
  jet booster, 350, 382  
  mast mount, 350, 382  
  mud, 50  
  opportunity fire, 86  
  picking up, 96  
  Record Sheets, Advanced, 12  
  shielding, 19-20  
  sinking vessel, 160  
  special attacks, 107-8  
  storm, 61  
  swamp, 51  
  tornado, 62

## • W •

Walls, 116, 129  
Warrior data, advanced 'Mech, 12  
Watchdog composite electronic warfare  
  system (CEWS), 278  
Water  
  airships, 164  
  ammo, 362-63  
  artillery, 184  
  battlefield wreckage, 187  
  ejection, 197  
  engine explosion, 78  
  hurried movement, 21  
Water flow, 50, 52-53  
  large naval vessel, 160  
Water hexes  
  gale, 61  
  hazardous liquid pools, 49  
  storm, 61  
  tornado, 62  
Water mobile structure collisions, 167  
Water mobile structure, 165  
  carrying units, 170  
  collisions, 167  
  line of sight, 171

## • Z •

Weapon  
  advanced, 380-85  
  advanced firing, 84  
  advanced support vehicles, 254, 255  
  destroyed, 121, 172  
  heavy and capital, 131  
  light and medium, 131  
  malfunction, 121, 172  
  mobile structures, 266-67  
  resolution dice, 109  
Weapon attack  
  boarded units, large naval vessels, 157  
  cargo bays, 188-89  
  damage, 83-84  
  dead zones, 79-80  
  double-blind rules, 225  
  extreme range, 85-87  
  fire, deep snow conditions, 41  
  fire, ice conditions, 50  
  fire, thin snow conditions, 52  
  glancing/direct blows, 80-81  
  gravity, 55  
  line of sight, 79-80, 85-87  
  missed shots, 81-83  
  partial cover, 87-88  
Weapon-delivered minefield, 208, 210  
Weather conditions, 29, 45, 57-68  
Weight, 237-38  
  advanced support vehicles, 240-45  
  minimum engine, 245, 247  
  mobile structure, 261  
  table, 241  
Weight class  
  physical attack modifiers, 23, 88  
  piloting skill roll modifiers, 90  
Wheeled vehicles, in thin snow, 52  
WiGE vehicle  
  atmospheric pressure and, 54  
  blowing sand and, 62  
  bonus MP and, 25-26  
  careful movement and, 64  
  gale and, 61  
  mobile structure and, 173  
  mud and, 50  
  storm and, 61  
  swamp and, 51  
  tornado and, 62  
Wind, 61-62  
  condition, 54, 55  
  direction, 57  
  shifting, 57  
  strength table, 47  
Withdrawal, infantry vs. infantry actions,  
  204  
Wood-burning generators, 135  
Woods, 40  
  engine explosion, 78

## • X •

Xenoplanetary condition-trained troops,  
  350, 351  
X-pulse lasers, 319, 321  
XXL fusion engines, 308, 309





# CLASSIC BATTLETECH

## ADVANCED GROUND VEHICLE RECORD SHEET

### VEHICLE DATA

Type: \_\_\_\_\_

Movement Points: \_\_\_\_\_ Tonnage: \_\_\_\_\_

Cruising: \_\_\_\_\_ Tech Base: \_\_\_\_\_

Flank: \_\_\_\_\_ Clan \_\_\_\_\_

Movement Type: \_\_\_\_\_ Inner Sphere

Engine Type: \_\_\_\_\_

### Weapons & Equipment Inventory (hexes)

Qty	Type	Loc	Dmg	Min	Sht	Med	Lng

Cost: \_\_\_\_\_ BV: \_\_\_\_\_

### CREW DATA

Crew: \_\_\_\_\_

Gunnery Skill: \_\_\_\_\_ Driving Skill: \_\_\_\_\_

Commander Hit **+1** Driver Hit **+2**

Modifier to all Skill rolls Modifier to Driving Skill rolls

### CRITICAL DAMAGE

Front Turret Locked  Engine Hit

Rear Turret Locked

Sensor Hits **+1 +2 +3**    **D**

Motive System Hits **+1 +2 +3**

Stabilizers

Front  Left  Right

Rear  Ft. Turret  Rr. Turret

### NOTES

### ARMOR DIAGRAM

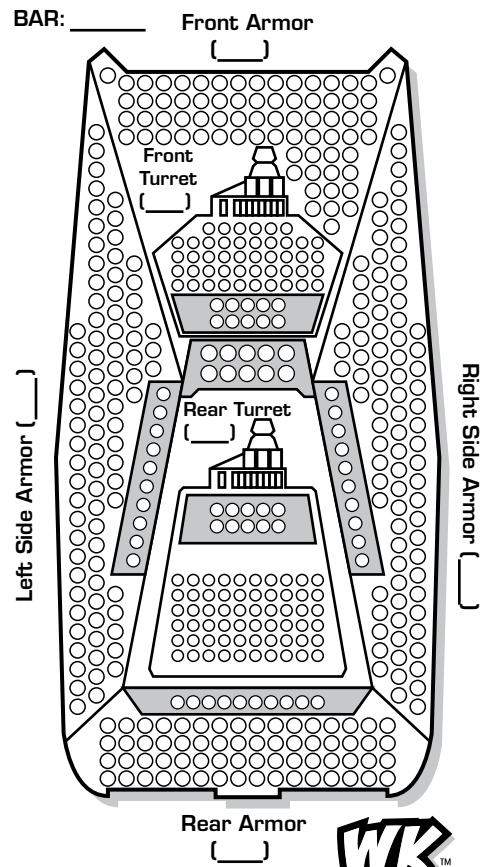

### GROUND COMBAT VEHICLE HIT LOCATION TABLE

2D6 Roll	ATTACK DIRECTION		
	FRONT	REAR	SIDE§
2*	Front (critical)	Rear (critical)	Side (critical)
3	Front †	Rear †	Side †
4	Front †	Rear †	Side †
5	Right Side †	Left Side †	Front †
6	Front	Rear	Side
7	Front	Rear	Side
8	Front	Rear	Side (critical)*
9	Left Side †	Right Side †	Rear †
10	Turret	Turret	Turret
11	Turret	Turret	Turret
12*	Turret (critical)	Turret (critical)	Turret (critical)

\*A result of 2 or 12 (or an 8 if the attack strikes the side) may inflict a critical hit on the vehicle. For each result of 2 or 12 (or 8 for side attacks), apply damage normally to the armor in that section. The attacking player then automatically rolls once on the Ground Combat Vehicle Critical Hits Table below (see *Combat*, p. 192 in *Total Warfare* for more information). A result of 12 on the Ground Combat Vehicles Hit Location Table may inflict critical hit against the turret; if the vehicle has no turret, a 12 indicates the chance of a critical hit on the side corresponding to the attack direction.

†The vehicle may suffer motive system damage even if its armor remains intact. Apply damage normally to the armor in that section, but the attacking player also rolls once on the Motive System Damage Table at right (see *Combat*, p. 192 in *Total Warfare* for more information). Apply damage at the end of the phase in which the damage takes effect.

§Side hits strike the side as indicated by the attack direction. For example, if an attack hits the right side, all Side results strike the right side armor. If the vehicle has no turret, a turret hit strikes the armor on the side attacked.

### MOTIVE SYSTEM DAMAGE TABLE

2D6 Roll	EFFECT*
2-5	No effect
6-7	Minor damage; +1 modifier to all Driving Skill Rolls
8-9	Moderate damage; -1 Cruising MP; +2 modifier to all Driving Skill Rolls
10-11	Heavy damage; only half Cruising MP (round fractions up), +3 modifier to all Driving Skill Rolls
12+	Major damage; no movement for the rest of the game. Vehicle is immobile.

<b>Attack Direction Modifier:</b>		<b>Vehicle Type Modifiers:</b>	
Hit from rear	+1	Tracked, Naval	+0
Hit from the sides	+2	Wheeled	+2
		Hovercraft, Hydrofoil	+3
		WIGE	+4

\*All movement and Driving Skill Roll penalties are cumulative. However, each Driving Skill Roll modifier can only be applied once. For example, if a roll of 6-7 is made for a vehicle, inflicting a +1 modifier, that is the only time that particular +1 can be applied; a subsequent roll of 6-7 has no additional effect. This means the maximum Driving Skill Roll modifier that can be inflicted from the Motive System Damage Table is +6. If a unit's Cruising MP is reduced to 0, it cannot move for the rest of the game, but is not considered an immobile target. In addition, all motive system damage takes effect at the end of the phase in which the damage occurred. For example, if two units are attacking the same Combat Vehicle during the Weapon Attack Phase and the first unit inflicts motive system damage and rolls a 12, the -4 immobile target modifier would not apply for the second unit. However, the -4 modifier would take effect during the Physical Attack Phase. If a hover vehicle is rendered immobile while over a Depth 1 or deeper water hex, it sinks and is destroyed.

### GROUND COMBAT VEHICLE CRITICAL HITS TABLE

2D6 Roll	LOCATION HIT			
	FRONT	SIDE	REAR	TURRET
2-5	No Critical Hit	No Critical Hit	No Critical Hit	No Critical Hit
6	Driver Hit	Cargo/Infantry Hit	Weapon Malfunction	Stabilizer
7	Weapon Malfunction	Weapon Malfunction	Cargo/Infantry Hit	Turret Jam
8	Stabilizer	Crew Stunned	Stabilizer	Weapon Malfunction
9	Sensors	Stabilizer	Weapon Destroyed	Turret Locks
10	Commander Hit	Weapon Destroyed	Engine Hit	Weapon Destroyed
11	Weapon Destroyed	Engine Hit	Ammunition**	Ammunition**
12	Crew Killed	Fuel Tank*	Fuel Tank*	Turret Blown Off

\*If Combat Vehicle has ICE engine only. If Combat Vehicle has a fusion engine, treat this result as Engine Hit.

\*\*If Combat Vehicle carries no ammunition, treat this result as Weapon Destroyed.







# CLASSIC BATTLETECH™



## ADVANCED CONVENTIONAL INFANTRY RECORD SHEET

### CONVENTIONAL INFANTRY: PLATOON/POINT 1

Experience: \_\_\_\_\_

Gunnery Skill: \_\_\_\_\_

Anti-'Mech Skill: \_\_\_\_\_

Max Weapon Damage\* \_\_\_\_\_

Notes: \_\_\_\_\_

\_\_\_\_\_

\_\_\_\_\_

\_\_\_\_\_

\*Damage is always applied in 2-point Damage Value groupings

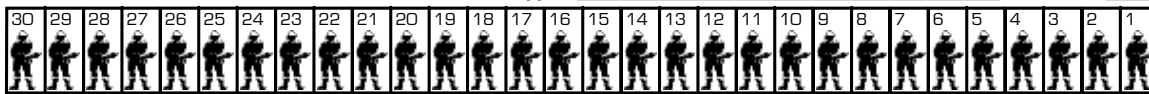

Armor Type: \_\_\_\_\_

Divisor: \_\_\_\_\_

**RANGE IN HEXES (TO-HIT MODIFIER)**

Range 0 1 2 3 4 5 6 7 8 9 10 11 12 13 14 15 16 17 18 19 20 21

Range Modifier \_\_\_\_\_

Field Gun Type: \_\_\_\_\_ Ammo: \_\_\_\_\_ Disposable Weapon: \_\_\_\_\_ Ammo: \_\_\_\_\_

Disposable Weapon: \_\_\_\_\_ Ammo: \_\_\_\_\_ Disposable Weapon: \_\_\_\_\_ Ammo: \_\_\_\_\_

Movement MP: \_\_\_\_\_ Type: \_\_\_\_\_

### CONVENTIONAL INFANTRY: PLATOON/POINT 2

Experience: \_\_\_\_\_

Gunnery Skill: \_\_\_\_\_

Anti-'Mech Skill: \_\_\_\_\_

Max Weapon Damage\* \_\_\_\_\_

Notes: \_\_\_\_\_

\_\_\_\_\_

\_\_\_\_\_

\_\_\_\_\_

\*Damage is always applied in 2-point Damage Value groupings

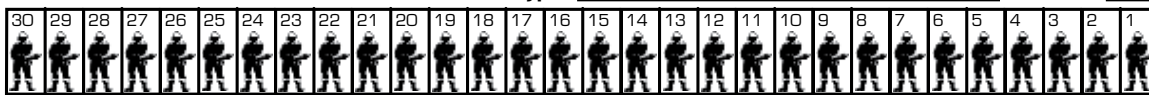

Armor Type: \_\_\_\_\_

Divisor: \_\_\_\_\_

**RANGE IN HEXES (TO-HIT MODIFIER)**

Range 0 1 2 3 4 5 6 7 8 9 10 11 12 13 14 15 16 17 18 19 20 21

Range Modifier \_\_\_\_\_

Field Gun Type: \_\_\_\_\_ Ammo: \_\_\_\_\_ Disposable Weapon: \_\_\_\_\_ Ammo: \_\_\_\_\_

Disposable Weapon: \_\_\_\_\_ Ammo: \_\_\_\_\_ Disposable Weapon: \_\_\_\_\_ Ammo: \_\_\_\_\_

Movement MP: \_\_\_\_\_ Type: \_\_\_\_\_

### BURST-FIRE WEAPON DAMAGE VS. CONVENTIONAL INFANTRY TABLE

#### 'MECHS, PROTOMECHS AND VEHICLES

WEAPON	DAMAGE vs. CONVENTIONAL INFANTRY
AP Gauss Rifle	2D6
Light Machine Gun	1D6
Machine Gun	2D6
Heavy Machine Gun	3D6
Small/Micro Pulse Laser	2D6
Flamer	4D6

#### BATTLE ARMOR

WEAPON	DAMAGE vs. CONVENTIONAL INFANTRY
Light Machine Gun	1D6/2 (round up)
Machine Gun	1D6
Heavy Machine Gun	2D6
Flamer	3D6
Light Recoilless Rifle	1D6
Medium Recoilless Rifle	2D6
Heavy Recoilless Rifle	2D6
Light Mortar	1D6
Heavy Mortar	1D6
Automatic Grenade Launcher	1D6/2 (round up)
Heavy Grenade Launcher	1D6

### MORALE TABLE

Experience Level	BattleMechs* Morale Target	Combat Vehicles† Morale Target	Infantry‡ Morale Target	Support Vehicles§ Morale Target
Green	4	6	9	10
Regular	2	4	6	7
Veteran	—§§	2	4	5
Elite	—§§	—§§	2	2

\* Includes ProtoMechs and aerospace fighters.

† Includes military conventional fighters, Small Craft and DropShips.

‡ Includes military Support Vehicles.

§ Includes IndustrialMechs (unless piloted by a military MechWarrior, in which case treat as a Combat Vehicle) and all civilian aerospace units.

§§ See Infernos and Cruise Missile Attack (p. 211).

#### SPECIAL SOURCE MODIFIER (ALL)

Inferno	+1/+3*
Cruise Missile	+2

\*The modifier to the left of the slash is for all non-infantry units, the modifier to the right of the slash for infantry.

#### ATTACK SOURCE MODIFIER (INFANTRY ONLY)

BattleMech in LOS	+1
Artillery	+2
Flamer or Fire	+3

#### OTHER MODIFIERS MODIFIER (INFANTRY ONLY)

Broken Morale	+1
Cumulative Modifiers	
Light or Medium Battle Armor Unit	-1
Heavy or Assault Battle Armor Unit	-2
Anti-Mech Skill of 5 or less	-1
Conventional Infantry with Armor (see p. 317)	-1
Unit in Building	-2

### NON-INFANTRY WEAPON DAMAGE AGAINST INFANTRY TABLE

WEAPON TYPE*	NUMBER OF CONVENTIONAL TROOPERS HIT†
Direct Fire (Ballistic or Energy)	Damage Value / 10
Cluster (Ballistic)	Damage Value / 10 + 1
Pulse**	Damage Value / 10 + 2
Cluster (Missile)	Damage Value / 5
Area-Effect (AE)	Damage Value / .5
Burst-Fire	See Burst-Fire Weapons Table
Physical Attack††	Damage Value / 10
Heat-Effect Weapons	See Heat-Effect Weapons‡

\* See Combat, p. 113 in Total Warfare, for weapon terminology.

\*\* Except for Small and Micro Pulse Lasers, which are treated as Burst-Fire Weapons.

† This equals the number of conventional infantry troopers hit and eliminated, regardless of armor protection.

‡ Attacks by non-infantry weapons against mechanized infantry double the number of troopers eliminated; round all fractions up.

†† Unless the physical attack weapon has a stated anti-infantry value (like the Combine), treat any physical attack as a Damage Value/10.

‡ Each Heat-Effect Weapon has specific damage against conventional infantry, as noted on either the appropriate Weapon and Equipment Tables or in Other Combat Weapons and Equipment (see p. 129 in Total Warfare).

### RECOVERING NERVE TABLE

NOTE: These modifiers only apply if a friendly unit/commander is within seventeen hexes of the unit attempting to recover its nerve.

#### COMMANDERS\*

Sub-force Commander in LOS	-1
Force Commander in LOS	-2

#### INFANTRY ONLY

Friendly non-'Mech, non-infantry unit in LOS	-1
Friendly 'Mech in LOS	-2
Another Routed Infantry Unit in LOS	+1
Another Routed Non-Infantry Unit in LOS	+2
Routed Unit	+3

\*Only applies if Commanders (see p. 191) are in use.





# CLASSIC BATTLETECH



## MOBILE STRUCTURE TEMPLATE

	Hex # _____		Hex # _____		Hex # _____
Hex # _____		Hex # _____		Hex # _____	
	Hex # _____		Hex # _____		Hex # _____
Hex # _____		Hex # _____		Hex # _____	
	Hex # _____		Hex # _____		Hex # _____
Hex # _____		Hex # _____		Hex # _____	
	Hex # _____		Hex # _____		Hex # _____
Hex # _____		Hex # _____		Hex # _____	
	Hex # _____		Hex # _____		Hex # _____
Hex # _____		Hex # _____		Hex # _____	
	Hex # _____		Hex # _____		Hex # _____
Hex # _____		Hex # _____		Hex # _____	
	Hex # _____		Hex # _____		Hex # _____
Hex # _____		Hex # _____		Hex # _____	
	Hex # _____		Hex # _____		Hex # _____





**LEGEND**

- Pivot Point
- T Turret
- F Forward Weapons
- L Left Weapons
- R Right Weapons
- FL Fore/Left Weapons
- FR Fore/Right Weapons
- AL Aft/Left Weapons
- AR Aft/Right Weapons
- A Aft Weapons

# CLASSIC BATTLETECH™

## LARGE NAVAL VESSEL TEMPLATES

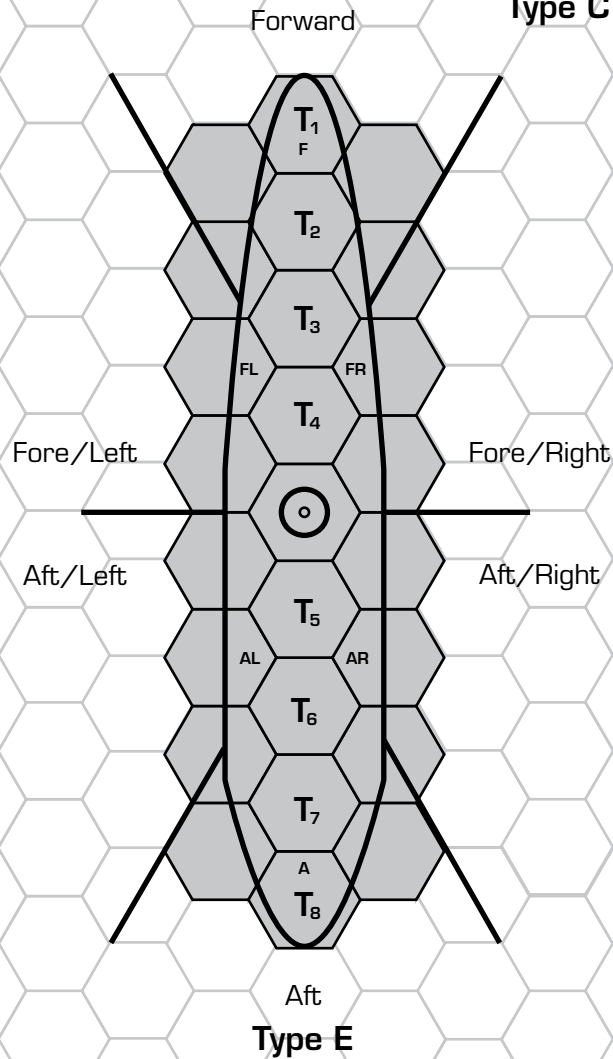
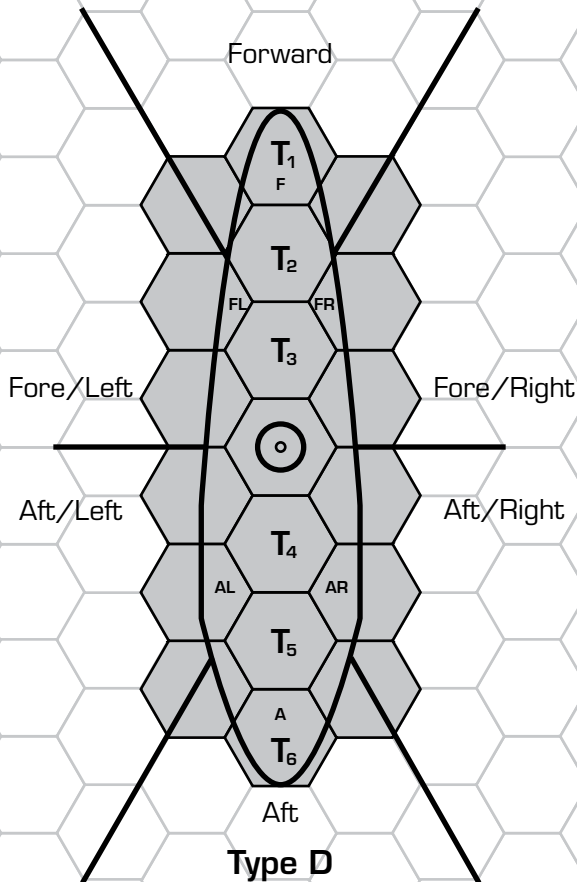
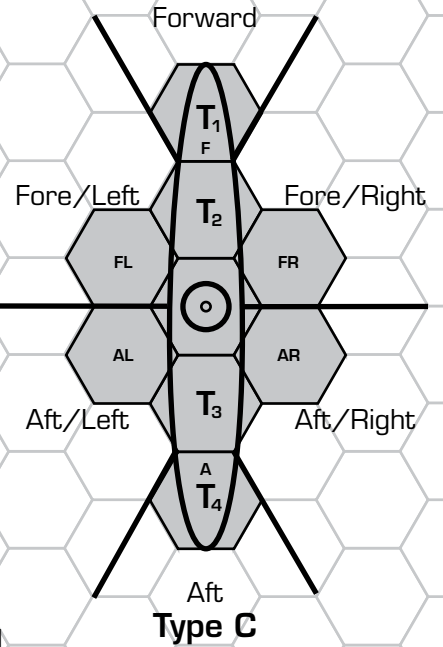
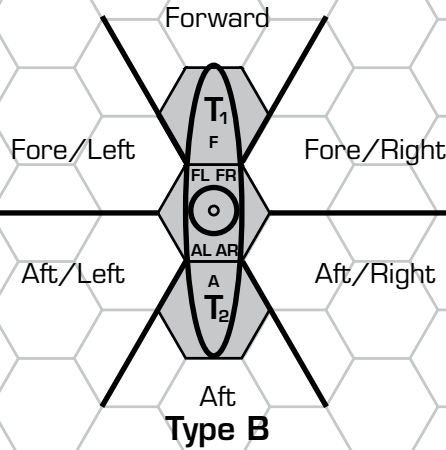
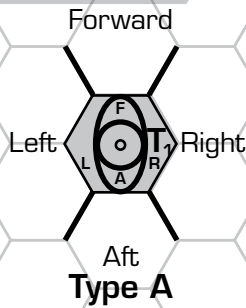



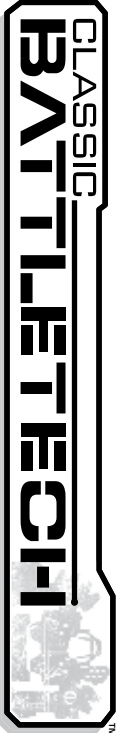

## LINE OF SIGHT CHART

### Unit Heights:

Standing Mech: 2 levels  
 Prone Mech: 1 level  
 ProtoMechs, Vehicles and Infantry: 1 level  
 Airborne Non-Aerospace Units: VTOLs and WJCE vehicles, or other units expending such MP (such as a battle armor unit expending VTOL MP), add their elevation +1 to the level of the underlying hex.  
 Airborne Large Support Vehicles add their elevation +2.  
 Submarines (non-template): A vessel on the surface rises 1 level above the level of the hex.  
 Ground Based Mobile Structures: Add 2 levels for "undercarriage"

Support Unit Template A: 0 levels above surface / 1 level below surface  
 Support Unit Template B: 1 level above surface / 1 level below surface  
 Support Unit Template C: 1 level above surface / 2 levels below surface  
 Support Unit Template D: 2 levels above surface / 2 levels below surface  
 Support Unit Template E: 3 levels above surface / 3 levels below surface  
 Large Support Vehicles: 2 levels  
 Grounded Fighters: 1 level  
 Grounded small craft: 2 levels  
 Grounded Aerodyne DropShip: 5 levels  
 Grounded Spheroid DropShip: 10 levels



LEVELS OR ELEVATIONS	DISTANCE (In Hexes)														
	1	2	3	4	5	6	7	8	9	10	11	12	13	14	15
11															
10															
9															
8															
7															
6															
5															
4															
3															
2															
1															
0															
-1															
-2															
-3															
-4															

LEVELS OR ELEVATIONS	DISTANCE (In Hexes)														
	1	2	3	4	5	6	7	8	9	10	11	12	13	14	15
11															
10															
9															
8															
7															
6															
5															
4															
3															
2															
1															
0															
-1															
-2															
-3															
-4															

# HEAVY WEAPONS AND EQUIPMENT COMBAT DATA

Weapon/Item	Type §	Heat Std (Aero)	Damage Std (Aero)	Range Min/Sht/Med/Lng (Aero)	Ammo (per Ton)	To-Hit Modifier	TC Comp	Rules Level	Ref
Active Probes									
Bloodhound AP	E	0 (0)	0 (0)	—/—/—/8 (*)	NA	NA	NA	Exp	278
Watchdog CEWS	E	0 (0)	0 (0)	—/—/—/4 (*)	NA	NA	NA	Exp	278
Actuator Enhancement Sys. (Arm)	T	0	0	NA (NA)	NA	-1*	NA	Exp	279
Actuator Enhancement Sys. (Leg)	PE, T	0	0	NA (NA)	NA	NA	NA	Exp	279
Angel ECM	E	0	0	—/—/—/6 (*)	NA	NA	NA	Exp	279
Armor									
Ferro-Lamellor	Armor	NA	NA	NA	NA	NA	NA	Exp	279
Hardened	Armor	NA	NA	NA	NA	NA	NA	Exp	280
Laser-Reflective (IS)	Armor	NA	NA	NA	NA	NA	NA	Exp	280
Laser-Reflective (Clan)	Armor	NA	NA	NA	NA	NA	NA	Exp	280
Modular	Armor	NA	NA	NA	NA	NA	NA	Exp	281
Reactive (IS)	Armor	NA	NA	NA	NA	NA	NA	Exp	282
Reactive (Clan)	Armor	NA	NA	NA	NA	NA	NA	Exp	282
Vehicular Stealth	E, Armor	10* (10*)	NA	NA	NA	NA	NA	Exp	282
Armored Components									
Armored Motive System (IS)	Armor	NA	NA	NA	NA	NA	NA	Exp	283
Armored Motive System (Clan)	Armor	NA	NA	NA	NA	NA	NA	Exp	283
Artemis V FCS	T	0	0	NA	NA	-1*	N	Exp	283
Artillery									
Arrow IV Missile (IS)	AE, S, F	10 (10*)	20A (NA)*	8 boards (NA)	5	0	N	Adv	284
Arrow IV Missile (Clan)	AE, S, F	10 (10*)	20A (NA)*	9 boards (NA)	5	0	N	Adv	284
Thumper	AE, S, F	6 (6*)	15A (NA)*	21 boards (NA)	20	0	N	Adv	284
Sniper	AE, S, F	10 (10*)	20A (NA)*	18 boards (NA)	10	0	N	Adv	284
Long Tom	AE, S, F	20 (20*)	25A (NA)*	30 boards (NA)	5	0	N	Adv	284
Cruise Missile/50	AE	50	50A (NA)*	50 boards (NA)	1/25	0	N	Exp	285
Cruise Missile/70	AE	70	70A (NA)*	90 boards (NA)	1/35	0	N	Exp	285
Cruise Missile/90	AE	90	90A (NA)*	120 boards (NA)	1/45	0	N	Exp	285
Cruise Missile/120	AE	120	120A (NA)*	150 boards (NA)	1/60	0	N	Exp	285
Artillery Cannons									
Thumper	DB, AE, S	5 (5)	5A (5)	3/4/9/14 (Medium)	20	0	N	Exp	285
Sniper	DB, AE, S	10 (10)	10A (10)	2/4/8/12 (Medium)	10	0	N	Exp	285
Long Tom	DB, AE, S	20 (20)	20A (20)	4/6/13/20 (Long)	5	0	N	Exp	285
Autocannons									
Hyper-Velocity AC/2	DB, S, X*	1 (1)	2 (2)	3/10/20/35 (Extreme)	30	0	Y	Exp	285
Hyper-Velocity AC/5	DB, S, X*	3 (3)	5 (5)	—/8/16/28 (Extreme)	15	0	Y	Exp	285
Hyper-Velocity AC/10	DB, S, X*	7 (7)	10 (10)	—/6/12/20 (Long)	8	0	Y	Exp	285
ProtoMech AC/2	DB, S	1 (1)	2 (2)	—/7/14/20 (Long)	40	0	Y	Adv	286
ProtoMech AC/4	DB, S	1 (1)	4 (4)	—/5/10/15 (Medium)	20	0	Y	Adv	286
ProtoMech AC/8	DB, S	2 (2)	8 (8)	—/3/7/10 (Short)	10	0	Y	Adv	286
Rotary AC/2 (Clan)	DB, R/C	1/sht (2)	2/Sht,R6* (8)	—/8/17/25 (Extreme)	45	0	Y*	Exp	286
Rotary AC/5 (Clan)	DB, R/C	1/sht (2)	5/sht,R6* (20)	—/7/14/21 (Long)	20	0	Y*	Exp	286
BattleMech/Vehicle HarJel	PE	NA	NA	NA (NA)	NA	NA	NA	Exp	288
BattleMech Melee Weapons									
Chain Whip	ME	0 (NA)	3* (NA)	PHYS (NA)	NA	-2*	N	Exp	288
Claws	ME	0 (NA)	1/7T* (NA)	PHYS (NA)	NA	0	N	Adv	289
Flail	ME	0 (NA)	9* (NA)	PHYS (NA)	NA	0	N	Exp	289
Lance	ME	0 (NA)	1/6T* (NA)	PHYS (NA)	NA	+1	N	Exp	290
Mace	ME	0 (NA)	1/4T* (NA)	PHYS (NA)	NA	+1	N	Adv	290
Shield, Small	ME, PD	0 (NA)	* (NA)	PHYS (NA)	NA	-2*	N	Exp	290
Shield, Medium	ME, PD	0 (NA)	* (NA)	PHYS (NA)	NA	-3*	N	Exp	290
Shield, Large	ME, PD	0 (NA)	* (NA)	PHYS (NA)	NA	-4*	N	Exp	290
Spikes	ME, PD	0 (NA)	* (NA)	PHYS (NA)	NA	NA	N	Exp	290
Talons	ME	0 (NA)	* (NA)	PHYS (NA)	NA	NA	N	Exp	290
Vibroblade, Small	ME, V	3* (NA)	7* (NA)	PHYS (NA)	NA	-2	N	Exp	292
Vibroblade, Medium	ME, V	5* (NA)	10* (NA)	PHYS (NA)	NA	-2	N	Exp	292
Vibroblade, Large	ME, V	7* (NA)	14* (NA)	PHYS (NA)	NA	-2	N	Exp	292
BattleMech/ProtoMech Motive Systems									
Jump Pack / Drop Pack	PE	0 (NA)	NA (NA)	NA (NA)	NA	NA	NA	Adv	292
Mechanical Jump Boosters	PE	0 (NA)	NA (NA)	NA (NA)	NA	NA	NA	Exp	292
Partial Wing ('Mech)	PE	* (NA)	NA (NA)	NA (NA)	NA	NA	NA	Exp	292
Partial Wing (ProtoMech)	PE	0 (NA)	NA (NA)	NA (NA)	NA	NA	NA	Exp	292
UMUs ('Mech)	PE	1* (NA)	NA (NA)	NA (NA)	NA	NA	NA	Exp	295
UMUs (ProtoMech)	PE	0 (NA)	NA (NA)	NA (NA)	NA	NA	NA	Exp	295
Blue Shield PFD	PD, X	0 (0)	NA (NA)	NA (NA)	NA	NA	NA	Exp	296
Booby Trap	AE, OS	NA (NA)	* (*)	* (*)	OS	NA	NA	Exp	297
C <sup>3</sup> Systems									
C <sup>3</sup> Boosted Master	E, CE, T	0 (0)	NA (NA)	NA (NA)	NA	NA	NA	Exp	298
C <sup>3</sup> Boosted Slave	E, CE, T	0 (0)	NA (NA)	NA (NA)	NA	NA	NA	Exp	298
C <sup>3</sup> Emergency Master	E, T	0 (0)	NA (NA)	NA (NA)	NA	NA	NA	Exp	298
C <sup>3</sup> Remote Sensor Launcher	M, E	0 (0)	NA (NA)	0/3/6/9 (Short)	4	NA	N	Exp	298
CASE II (IS)	PE	NA (NA)	NA (NA)	NA (NA)	NA	NA	NA	Exp	299

\*See rules for this equipment in the *Advanced Weapons And Equipment* section, starting on p. 274.

# HEAVY WEAPONS AND EQUIPMENT CONSTRUCTION DATA

Weapon/Item	Tech Base	Tech Rating	Latest Intro Date (IS / Clan)	Item / Ammo Cost (C-bills)	Weight (Tons)	Space \$§										
						M	P	CV	SV	F	SC	DS	JS	WS	SS	MS
Active Probes																
Bloodhound AP	IS	E/X-X-F	3058P / NA	500,000	2	3	NA	1	3	1	1	1	NA	NA	NA	1
Watchdog CEWS	Clan	F/X-X-F	NA / 3059P	600,000	1.5	2	1	1	2	1	1	1	NA	NA	NA	1
Actuator Enhancement Sys. (Arm)	IS/Clan	E/X-X-F	3070P / 3070P	500xTT	*	*	NA	NA	NA	NA	NA	NA	NA	NA	NA	NA
Actuator Enhancement Sys. (Leg)	IS/Clan	E/X-X-F	3070P / 3070P	700xTT	*	*	NA	NA	NA	NA	NA	NA	NA	NA	NA	NA
Angel ECM	IS/Clan	F/X-X-F	3057P / 3058P	750,000	2	2	1	1	2	1	1	1	NA	NA	NA	1
Armor																
Ferro-Lamellor	Clan	F/X-X-F	NA / 3070P	35,000xAT	*	12	NA	1	1*	2*	NA	NA	NA	NA	NA	NA
Hardened	IS/Clan	D/X-X-F	3047P / 3061P	15,000xAT	*	0	NA	1*	NA	NA	NA	NA	NA	NA	NA	NA
Laser-Reflective (IS)	IS	E/X-X-F	3058P / NA	30,000xAT	*	10	NA	1	1*	2*	NA	NA	NA	NA	NA	NA
Laser-Reflective (Clan)	Clan	F/X-X-F	NA / 3061P	30,000xAT	*	5	NA	1	1*	1*	NA	NA	NA	NA	NA	NA
Modular	IS/Clan	D/X-X-F	3072P / 3074P	10,000xAT	1*	1*	NA	1	1*	2	NA	NA	NA	NA	NA	NA
Reactive (IS)	IS	E/X-X-F	3063P / NA	30,000xAT	*	14	NA	2	2*	3*	NA	NA	NA	NA	NA	NA
Reactive (Clan)	Clan	F/X-X-F	NA / 3065P	30,000xAT	*	7	NA	1	1*	2*	NA	NA	NA	NA	NA	NA
Vehicular Stealth	IS	E/X-X-F	3067P / NA	50,000xAT	*	NA	NA	2*	2*	2*	NA	NA	NA	NA	NA	NA
Armored Components	IS/Clan	E/X-X-F	3061P / 3061P	150,000xCS	+0.5**	0	NA	NA	NA	NA	NA	NA	NA	NA	NA	NA
Armored Motive System (IS)	IS	E/X-X-F	NA / 3071P	100,000xIT	0.15xTT*	NA	NA	0	0	NA	NA	NA	NA	NA	NA	NA
Armored Motive System (Clan)	Clan	F/X-X-F	3057P / NA	100,000xIT	0.10xTT*	NA	NA	0	0	NA	NA	NA	NA	NA	NA	NA
Artemis V FCS	Clan	F/X-X-F	NA / 3061P	250,000 / x5	+1.5**	+2**	NA	+0	+2**	+0	+0	+0	+0	+0	+0	+0
Artillery																
Arrow IV Missile (IS)	IS	E/E-F-E	3044 / 2600	450,000 / 10,000	15	15	NA	1	15	1	1	1	NA	NA	NA	1
Arrow IV Missile (Clan)	Clan	F/E-F-E	NA / 2850	450,000 / 10,000	12	12	NA	1	12	1	1	1	NA	NA	NA	1
Thumper	IS/Clan	B/C-C-C	PS / PS	187,500 / 4,500	15	15	NA	1	15	1	1	1	NA	NA	NA	1
Sniper	IS/Clan	B/C-C-C	PS / PS	300,000 / 6,000	20	20	NA	1	20	1	1	1	NA	NA	NA	1
Long Tom	IS/Clan	B/C-C-C	PS / PS	450,000 / 10,000	30	NA	NA	1	30	NA	1	1	NA	NA	NA	1
Cruise Missile/50	IS	E/X-X-F	3065P / NA	900,000 / 20,000	55	NA	NA	1	55	NA	1	1	NA	NA	NA	1
Cruise Missile/70	IS	E/X-X-F	3065P / NA	1,250,000 / 50,000	80	NA	NA	1	80	NA	1	1	NA	NA	NA	1
Cruise Missile/90	IS	E/X-X-F	3065P / NA	2,550,000 / 90,000	100	NA	NA	1	100	NA	1	1	NA	NA	NA	1
Cruise Missile/120	IS	E/X-X-F	3065P / NA	3,000,000 / 140,000	135	NA	NA	1	120	NA	1	1	NA	NA	NA	1
Artillery Cannons																
Thumper	IS/Clan	B/X-F-E	3012P / 3032P	200,000 / 10,000	10	7	NA	1	7	1	1	1	NA	NA	NA	1
Sniper	IS/Clan	B/X-F-E	3012P / 3032P	475,000 / 15,000	15	10	NA	1	10	1	1	1	NA	NA	NA	1
Long Tom	IS/Clan	B/X-F-E	3012P / 3032P	650,000 / 20,000	20	15	NA	1	15	1	1	1	NA	NA	NA	1
Autocannons																
Hyper-Velocity AC/2	IS	D/X-X-F	3059P / NA	100,000 / 3,000	8	2	NA	1	2	1	1	1	1	1	1	1
Hyper-Velocity AC/5	IS	D/X-X-F	3059P / NA	160,000 / 10,000	12	4	NA	1	4	1	1	1	1	1	1	1
Hyper-Velocity AC/10	IS	D/X-X-F	3060P / NA	230,000 / 20,000	14	6	NA	1	6	1	1	1	1	1	1	1
ProtoMech AC/2	Clan	F/X-X-F	NA / 3073	95,000 / 1,200	3.5	2	1*	1	2	1	1	1	1	1	1	1
ProtoMech AC/4	Clan	F/X-X-F	NA / 3073	133,000 / 4,800	4.5	3	1*	1	3	1	1	1	1	1	1	1
ProtoMech AC/8	Clan	F/X-X-F	NA / 3073	175,000 / 6,300	5.5	4	1*	1	4	1	1	1	1	1	1	1
Rotary AC/2 (Clan)	Clan	F/X-X-F	NA / 3073P	175,000 / 3,000	8	4	NA	1	4	1	1	1	1	1	1	1
Rotary AC/5 (Clan)	Clan	F/X-X-F	NA / 3073P	275,000 / 12,000	10	8	NA	1	8	1	1	1	1	1	1	1
BattleMech/Vehicle HarJel	IS/Clan	E-X-X-E	3067P / 3059P	120,000xCS	1*	1*	NA	1*	1*	NA	NA	NA	NA	NA	NA	NA
BattleMech Melee Weapons																
Chain Whip	IS	C/X-X-F	3071P / NA	120,000	3	2*	NA	NA	NA	NA	NA	NA	NA	NA	NA	NA
Claws	IS	B/X-F-E	3060 / NA	200xTT	TT÷15*	TT÷15*	NA	NA	NA	NA	NA	NA	NA	NA	NA	NA
Flail	IS	B/X-X-E	3057P / NA	110,000	5	4*	NA	NA	NA	NA	NA	NA	NA	NA	NA	NA
Lance	IS	C/X-X-F	3064P / NA	150xTT	TT÷20*	TT÷20*	NA	NA	NA	NA	NA	NA	NA	NA	NA	NA
Mace	IS	B/X-F-D	3061 / NA	130,000	TT÷10*	TT÷10*	NA	NA	NA	NA	NA	NA	NA	NA	NA	NA
Shield, Small	IS	D/X-X-F	3067P / NA	50,000	2	3	NA	NA	NA	NA	NA	NA	NA	NA	NA	NA
Shield, Medium	IS	D/X-X-F	3067P / NA	100,000	4	5	NA	NA	NA	NA	NA	NA	NA	NA	NA	NA
Shield, Large	IS	D/X-X-F	3067P / NA	300,000	6	7	NA	NA	NA	NA	NA	NA	NA	NA	NA	NA
Spikes	IS	C/X-E-E	3051 / NA	50xTT	0.5	1	NA	NA	NA	NA	NA	NA	NA	NA	NA	NA
Talons	Clan	E/X-X-F	NA / 3072	300xTT	TT÷15*	*	NA	NA	NA	NA	NA	NA	NA	NA	NA	NA
Vibroblade, Small	IS	D/X-X-E	3065P / NA	150,000	3	1	NA	NA	NA	NA	NA	NA	NA	NA	NA	NA
Vibroblade, Medium	IS	D/X-X-E	3065P / NA	400,000	5	2	NA	NA	NA	NA	NA	NA	NA	NA	NA	NA
Vibroblade, Large	IS	D/X-X-E	3066P / NA	750,000	7	4	NA	NA	NA	NA	NA	NA	NA	NA	NA	NA
BattleMech/ProtoMech Motive Systems																
Jump Pack / Drop Pack	IS/Clan	D/C-D-C	2457 / 2457	20,000xIT	Var*	0	0	NA	NA	NA	NA	NA	NA	NA	NA	NA
Mechanical Jump Boosters	IS	E/X-X-F	3060P / NA	†	Var*	*	NA	NA	NA	NA	NA	NA	NA	NA	NA	NA
Partial Wing (Mech)	Clan	F/X-X-E	NA / 3067P	50,000xIT	TT÷20*	6*	NA	NA	NA	NA	NA	NA	NA	NA	NA	NA
Partial Wing (ProtoMech)	Clan	F/X-X-E	NA / 3070P	50,000xIT	TT÷5*	NA	1*	NA	NA	NA	NA	NA	NA	NA	NA	NA
UMUs (Mech)	IS/Clan	E/X-X-E	3066P / 3061P	†	Var*	*	NA	NA	NA	NA	NA	NA	NA	NA	NA	NA
UMUs (ProtoMech)	Clan	E/X-X-E	NA / 3061P	†	Var*	NA	0*	NA	NA	NA	NA	NA	NA	NA	NA	NA
Blue Shield PFD	IS	E/X-X-F	3053P / NA	1,000,000	3	7*	NA	Var*	Var*	4*	NA	NA	NA	NA	NA	NA
Booby Trap	IS	B/D-F-D	PS / NA	100,000	Var*	1*	NA	1*	1*	1*	1*	0*	0*	0*	0*	0*
C³ Systems																
C³ Boosted Master	IS	E/X-X-F	3073P / NA	3,000,000	6	6*	NA	1*	6*	1*	NA	NA	NA	NA	NA	1
C³ Boosted Slave	IS	E/X-X-F	3073P / NA	500,000	3	2*	NA	1*	2*	1*	NA	NA	NA	NA	NA	1
C³ Emergency Master	IS	E/X-X-F	3071P / NA	2,800,000	2	2*	NA	1*	2*	1*	NA	NA	NA	NA	NA	1
C³ Remote Sensor Launcher	IS	E/X-X-F	3072P / NA	400,000 / 100,000	4	3	NA	1	3	1	1	NA	NA	NA	NA	1
CASE II (IS)	IS	E/X-X-F	3064P / NA	175,000	1	1	NA	NA	NA	1	NA	NA	NA	NA	NA	NA

\*See rules for this equipment in the *Advanced Weapons And Equipment* section, starting on p. 274.

Weapon/Item	Type S	Heat Std (Aero)	Damage Std (Aero)	Range (Aero)	Ammo (per Ton)	To-Hit Modifier	TC Comp	Rules Level	Ref
CASE II (Clan)	PE	NA (NA)	NA (NA)	NA (NA)	NA	NA	NA	Exp	299
Chaff Pod	PD, E, OS	0 (0)	NA (NA)	NA (NA)	OS	NA	NA	Exp	299
Chameleon LPS	E	6 (NA)	NA (NA)	NA (NA)	NA	NA	NA	Exp	300
Cockpit Systems									
Cockpit Command Console	PE	NA (NA)	NA (NA)	NA (NA)	NA	NA	NA	Adv	300
Small Aerospace Cockpit	PE	NA (NA)	NA (NA)	NA (NA)	NA	NA	NA	Adv	300
Torso-Mounted Cockpit	PE	NA (NA)	NA (NA)	NA (NA)	NA	NA	NA	Exp	300
Collapsible Command Module	E	NA (NA)	NA (NA)	NA (NA)	NA	NA	NA	Exp	301
Combat Vehicle Chassis Mods									
Flotation Hull	PE	NA (NA)	NA (NA)	NA (NA)	NA	NA	NA	Adv	302
Limited Amphibious	PE	NA (NA)	NA (NA)	NA (NA)	NA	NA	NA	Adv	302
Fully Amphibious	PE	NA (NA)	NA (NA)	NA (NA)	NA	NA	NA	Adv	303
Dune Buggy	PE	NA (NA)	NA (NA)	NA (NA)	NA	NA	NA	Adv	303
Enviro (Vacuum) Sealing	PE	NA (NA)	NA (NA)	NA (NA)	NA	NA	NA	Adv	303
Coolant Pod	PE, OS	* (*)	NA (NA)	NA (NA)	OS	NA	NA	Exp	303
Docking Hardpoint	PE	NA (NA)	NA (NA)	NA (NA)	NA	NA	NA	Adv	304
Docking Thrusters	PE	NA (NA)	NA (NA)	NA (NA)	NA	NA	NA	Adv	305
Drone (Remote) Systems									
Drone Carrier Control System	E	NA (NA)	NA (NA)	* (*)	NA	NA	NA	Adv	305
Drone Operating System	E	NA (NA)	NA (NA)	* (*)	NA	+1*	NA	Adv	306
Energy Storage Battery	PE	NA (NA)	NA (NA)	NA (NA)	NA	NA	NA	Adv	306
Engines									
Combat Vehicle Fission	Engine	NA (NA)	NA (NA)	NA (NA)	NA	NA	NA	Adv	307
Combat Vehicle Fuel Cell	Engine	NA (NA)	NA (NA)	NA (NA)	NA	NA	NA	Adv	307
Large (ICE)	Engine	NA (NA)	NA (NA)	NA (NA)	NA	NA	NA	Exp	307
Large (Fusion)	Engine	NA (NA)	NA (NA)	NA (NA)	NA	NA	NA	Exp	307
Large (Light Fusion)	Engine	NA (NA)	NA (NA)	NA (NA)	NA	NA	NA	Exp	307
Large (XL – Inner Sphere)	Engine	NA (NA)	NA (NA)	NA (NA)	NA	NA	NA	Exp	307
Large (XL – Clan)	Engine	NA (NA)	NA (NA)	NA (NA)	NA	NA	NA	Exp	307
Large (XXL – Inner Sphere)	Engine	NA (NA)	NA (NA)	NA (NA)	NA	NA	NA	Exp	307
Large (XXL – Clan)	Engine	NA (NA)	NA (NA)	NA (NA)	NA	NA	NA	Exp	307
XXL Fusion (Inner Sphere)	Engine	NA (NA)	NA (NA)	NA (NA)	NA	NA	NA	Exp	309
XXL Fusion (Clan)	Engine	NA (NA)	NA (NA)	NA (NA)	NA	NA	NA	Exp	309
Ejection Systems									
Combat Vehicle Escape Pod	PE, OS	NA (NA)	NA (NA)	NA (NA)	OS	NA	NA	Exp	309
Full-Head Ejection System	PE, OS	NA (NA)	NA (NA)	NA (NA)	NA	NA	NA	Adv	310
Electronic Warfare Equipment	E	NA (NA)	NA (NA)	—/—/—/3 (*)	NA	NA	NA	Exp	310
Flamers									
ER Flamer	DE, H, AI	4 (4)	2* (2)	0/3/5/7 (Short)	NA	0	N	Adv	312
Heavy Flamer	DE, H, AI	5 (5)	4* (4)	0/2/3/4 (Short)	10	0	N	Adv	312
Flight Deck / Helipad									
Flight Deck	PE	NA (NA)	NA (NA)	NA (NA)	NA	NA	NA	Adv	312
Helipad	PE	NA (NA)	NA (NA)	NA (NA)	NA	NA	NA	Adv	312
Fluid Gun	DE, S	0 (0)	* (*)	0/1/2/3 (Short)	20	0	N	Adv	313
Gauss Rifles									
Improved Heavy Gauss	DB, X	2 (2)	22 (22)	3/6/12/19 (Long)	4	0	Y	Exp	313
MagShot	DB, X	1 (1)	2 (2)	0/3/6/9 (Short)	50	0	Y	Adv	314
Silver Bullet Gauss	DB, C, F, X	1 (1)	C1/15 (9)	2/7/15/22 (Long)	8	-1	Y	Exp	314
Grav Decks									
(less than 100-meter diameter)	PE	NA (NA)	NA (NA)	NA (NA)	NA	NA	NA	Adv	315
(100- to 250-meter diameter)	PE	NA (NA)	NA (NA)	NA (NA)	NA	NA	NA	Adv	315
(over 250-meter diameter)	PE	NA (NA)	NA (NA)	NA (NA)	NA	NA	NA	Adv	315
Grenade Launcher, Vehicular	AE, OS	1 (1)	* (*)	—/—/—/1 (*)	OS	NA	N	Adv	315
Handheld Weapon	PE	0 (NA)	Var* (NA)	Var* (NA)	Var*	Var*	N	Exp	315
Heat Sinks									
Compact Heat Sinks	PE	-1 (NA)	NA (NA)	NA (NA)	NA	NA	NA	Exp	316
Laser Heat Sinks	PE	-2 (NA)	NA (NA)	NA (NA)	NA	NA	NA	Adv	316
Landing Deck	PE	NA (NA)	NA (NA)	NA (NA)	NA	NA	NA	Adv	319
Lasers									
Binary Laser (Blazer) Cannon	DE	12 (12)	16 (16)	0/5/10/15 (Medium)	NA	0	Y	Exp	319
Bombast Laser	DE, V	* (12)	* (12)	0/5/10/15 (Medium)	NA	Var*	Y	Exp	320
Chemical Laser, Small	DE	1 (1)	3 (3)	0/1/2/3 (Short)	60	0	Y	Exp	320
Chemical Laser, Medium	DE	2 (2)	5 (5)	0/3/6/9 (Short)	30	0	Y	Exp	320
Chemical Laser, Large	DE	6 (6)	8 (8)	0/5/10/15 (Medium)	10	0	Y	Exp	320
ER Pulse Laser, Small	P, AI	3 (3)	5 (5)	0/2/4/6 (Short)	NA	-1	Y*	Exp	320
ER Pulse Laser, Medium	P	6 (6)	7 (7)	0/5/9/14 (Medium)	NA	-1	Y*	Exp	320
ER Pulse Laser, Large	P	13 (13)	10 (10)	0/7/15/23 (Long)	NA	-1	Y*	Exp	320
Improved Heavy Laser, Small	DE	3 (3)	6 (6)	0/1/2/3 (Short)	NA	0	Y	Exp	321
Improved Heavy Laser, Medium	DE	7 (7)	10 (10)	0/3/6/9 (Short)	NA	0	Y	Exp	321
Improved Heavy Laser, Large	DE	18 (18)	16 (16)	0/5/10/15 (Medium)	NA	0	Y	Exp	321
Variable-Speed Laser, Small	P, V, AI	3 (3)	5/4/3* (4)	0/2/4/6 (Short)	NA	Var*	Y*	Adv	321
Variable-Speed Laser, Medium	P, V, AI	7 (7)	9/7/5* (7)	0/2/5/9 (Short)	NA	Var*	Y*	Adv	321
Variable-Speed Laser, Large	P, V, AI	10 (10)	11/9/7* (10/7*)	0/4/8/15 (Medium)	NA	Var*	Y*	Adv	321
X-Pulse Laser, Small	P, AI	3 (3)	3 (3)	0/2/4/5 (Short)	NA	-2	Y*	Exp	321

\*See rules for this equipment in the *Advanced Weapons And Equipment* section, starting on p. 274.

Weapon/Item	Tech Base	Tech Rating	Latest Intro Date (IS / Clan)	Item / Ammo Cost (C-bills)	Weight (Tons)	Space §§											
						M	P	CV	SV	F	SC	DS	JS	WS	SS	MS	
CASE II (Clan)	Clan	F/X-X-F	NA / 3062P	175,000	0.5	1	NA	NA	NA	1	NA	NA	NA	NA	NA	NA	NA
Chaff Pod	IS	C/X-X-E	NA / 3069P	2,000	1	1	NA	1	1	1	1	1	NA	NA	NA	1	
Chameleon LPS	IS	E/F-X-X	2630X / 2630	600,000	0	6*	NA	NA	NA	NA	NA	NA	NA	NA	NA	NA	
Cockpit Systems																	
Cockpit Command Console	IS/Clan	D/C-F-E	3030 / 2631	500,000	3*	1*	NA	1*	1*	1*	NA	NA	NA	NA	NA	NA	
Small Aerospace Cockpit	IS	E/X-X-E	3070 / NA	175,000	2*	NA	NA	NA	NA	0*	NA	NA	NA	NA	NA	NA	
Torso-Mounted Cockpit	IS/Clan	E/X-X-F	3053P / 3055P	750,000	4*	1*	NA	NA	NA	NA	NA	NA	NA	NA	NA	NA	
Collapsible Command Module	IS	D/E-F-E	2710 / 2710	500,000	16	12	NA	NA	NA	NA	NA	NA	NA	NA	NA	NA	
Combat Vehicle Chassis Mods																	
Flotation Hull	IS/Clan	B/B-B-B	PS / PS	1.25xTC	0*	NA	NA	0*	NA	0*	NA	NA	NA	NA	NA	NA	
Limited Amphibious	IS/Clan	B/B-B-B	PS / PS	10,000xIT	TT÷25*	NA	NA	0*	NA	NA	NA	NA	NA	NA	NA	NA	
Fully Amphibious	IS/Clan	B/B-B-B	PS / PS	10,000xIT	TT÷10*	NA	NA	0*	NA	NA	NA	NA	NA	NA	NA	NA	
Dune Buggy	IS/Clan	B/B-B-B	PS / PS	10xTTxTT	0*	NA	NA	0*	NA	NA	NA	NA	NA	NA	NA	NA	
Enviro (Vacuum) Sealing	IS/Clan	B/C-D-C	PS / PS	1.25xTC	TT÷10*	NA	NA	0*	NA	NA	NA	NA	NA	NA	NA	NA	
Coolant Pod	IS/Clan	D/X-X-E	3049P / 3056P	50,000	1	1	NA	NA	NA	1	NA	NA	NA	NA	NA	NA	
Docking Hardpoint	IS/Clan	B/C-C-C	ES / ES	100,000	1,000	NA	NA	NA	NA	NA	NA	0	0	0	0	1	
Docking Thrusters	IS/Clan	B/C-C-C	PS / PS	15,000xIT	TT÷50*	NA	NA	NA	3*	NA	NA	NA	NA	NA	NA	NA	
Drone (Remote) Systems																	
Drone Carrier Control System	IS/Clan	C/E-F-F	ES / ES	10,000xIT	Var*	NA	NA	1	1	NA	0	0	0	0	0	0	
Drone Operating System	IS/Clan	C/E-F-F	ES / ES	5,000+(10,000xIT)	Var*	1*	NA	1*	1*	1*	NA	NA	NA	NA	NA	NA	
Energy Storage Battery	IS/Clan	D/C-E-D	2131 / 2131	1,000,000	100,000	NA	NA	NA	NA	NA	NA	NA	NA	NA	0	NA	
Engines																	
Combat Vehicle Fission	IS	D/E-E-D	2882 / NA	(7,500xERxTT)÷75	*	*	NA	*	NA	*	NA	NA	NA	NA	NA	NA	
Combat Vehicle Fuel Cell	IS/Clan	D/C-D-D	ES / ES	(3,500xERxTT)÷75	*	*	NA	*	NA	NA	NA	NA	NA	NA	NA	NA	
XXL Fusion (Inner Sphere)	IS	F/X-X-F	3055P / 2954X	(100,000xERxTT)÷75	*	+12*	NA	+4*	NA	+4*	NA	NA	NA	NA	NA	NA	
XXL Fusion (Clan)	Clan	F/X-X-F	NA / 3030P	(100,000xERxTT)÷75	*	+8*	NA	+3*	NA	+3*	NA	NA	NA	NA	NA	NA	
Large (ICE)	IS/Clan	C/A-A-A	2630P / 2630P	(2,500xERxTT)÷75	*	+2*	NA	+1*	NA	+1*	NA	NA	NA	NA	NA	NA	
Large (Fusion)	IS/Clan	D/C-E-D	2630P / 2630P	(10,000xERxTT)÷75	*	+2*	NA	+1*	NA	+1*	NA	NA	NA	NA	NA	NA	
Large (Light Fusion)	IS	E/X-X-E	3065P / NA	(30,000xERxTT)÷75	*	+6*	NA	+2*	NA	+2*	NA	NA	NA	NA	NA	NA	
Large (XL – Inner Sphere)	IS	E/D-F-E	3045P / 2635X	(40,000xERxTT)÷75	*	+8*	NA	+3*	NA	+3*	NA	NA	NA	NA	NA	NA	
Large (XL – Clan)	Clan	E/D-F-E	NA / 2840P	(40,000xERxTT)÷75	*	+6*	NA	+2*	NA	+2*	NA	NA	NA	NA	NA	NA	
Large (XXL – Inner Sphere)	IS	F/X-X-F	3057P / NA	(200,000xERxTT)÷75	*	+14*	NA	+5*	NA	+5*	NA	NA	NA	NA	NA	NA	
Large (XXL – Clan)	Clan	F/X-X-F	NA / 2970P	(200,000xERxTT)÷75	*	+10*	NA	+3*	NA	+3*	NA	NA	NA	NA	NA	NA	
Ejection Systems																	
Combat Vehicle Escape Pod	IS	D/X-X-E	3038P / NA	10,000	4	NA	NA	1*	NA	NA	NA	NA	NA	NA	NA	NA	
Full-Head Ejection System	IS/Clan	D/X-X-E	3023 / 3052	1,725,000	0	0*	NA	NA	NA	NA	NA	NA	NA	NA	NA	NA	
Electronic Warfare Equipment	IS	D/X-F-E	3025 / NA	500,000	7.5	4	NA	1	1	1	1	1	NA	NA	NA	1	
Flamers																	
ER Flamer	IS/Clan	D/X-X-E	3070 / 3067	15,000	1	1	1	1	1	1	1	1	1	1	1	1	
Heavy Flamer	IS/Clan	C/X-X-E	3068 / 3067	11,250 / 2,000	1.5	1	1	1	1	1	1	1	NA	NA	NA	1	
Flight Deck / Helipad																	
Flight Deck	IS/Clan	B/A-A-A	PS / PS	1,000,000	25,000	NA	NA	NA	10	NA	NA	NA	NA	NA	NA	1	
Helipad	IS/Clan	B/A-A-A	PS / PS	200,000	500	NA	NA	NA	5	NA	NA	NA	NA	NA	NA	1	
Fluid Gun	IS/Clan	B/B-B-B	PS / PS	35,000 / 500	2	2	NA	1	1	1	1	1	NA	NA	NA	1	
Gauss Rifles																	
Improved Heavy Gauss	IS	E/X-X-F	3065P / NA	700,000 / 20,000	20	11	NA	1	11	1	1	1	1	1	1	1	
MagShot	IS	E/X-X-D	3072P / NA	8,500 / 1,000	0.5	2	NA	1	2	1	1	1	1	1	1	1	
Silver Bullet Gauss	IS	D/X-X-F	3051P / NA	350,000 / 25,000	15	7	NA	1	7	1	1	1	1	1	1	1	
Grav Decks																	
(less than 100-meter diameter)	IS/Clan	B/C-C-C	ES / ES	5,000,000	50	NA	NA	NA	NA	NA	NA	NA	0	0	0	NA	
(100- to 250-meter diameter)	IS/Clan	B/C-C-C	ES / ES	10,000,000	100	NA	NA	NA	NA	NA	NA	NA	0	0	0	NA	
(over 250-meter diameter)	IS/Clan	B/C-C-C	ES / ES	40,000,000	500	NA	NA	NA	NA	NA	NA	NA	NA	NA	0	NA	
Grenade Launcher, Vehicular	IS/Clan	C/D-E-F	PS / PS	10,000	0.5	1	1	1	1	1	1	1	NA	NA	NA	1	
Handheld Weapon	IS/Clan	D/E-E-F	3055P / 2490P	2xIC++	*	*	*	NA	NA	NA	NA	NA	NA	NA	NA	NA	
Heat Sinks																	
Compact Heat Sinks	IS	E/X-X-F	3058P / NA	3,000	1.5	1*	NA	NA	NA	NA	NA	NA	NA	NA	NA	NA	
Laser Heat Sinks	Clan	F/X-X-E	NA / 3051	6,000	1	3*	NA	NA	NA	NA	NA	NA	NA	NA	NA	NA	
Landing Deck	IS/Clan	B/C-C-C	ES / ES	500,000xHX	500xHX*	1xHX*	NA	NA	NA	NA	NA	NA	NA	NA	NA	1*	
Lasers																	
Binary Laser (Blazer) Cannon	IS	D/X-E-E	2812P / NA	200,000	9	4	NA	1	4	1	1	1	1	1	1	1	
Bombast Laser	IS	E/X-X-E	3064P / NA	200,000	7	3	NA	1	3	1	1	1	1	1	1	1	
Chemical Laser, Small	Clan	E/X-X-E	NA / 3059P	10,000 / 30,000	0.5	1	1	1	1	1	1	1	1	1	1	1	
Chemical Laser, Medium	Clan	E/X-X-E	NA / 3059P	30,000 / 30,000	1	1	1	1	1	1	1	1	1	1	1	1	
Chemical Laser, Large	Clan	E/X-X-E	NA / 3059P	75,000 / 30,000	5	2	NA	1	2	1	1	1	1	1	1	1	
ER Pulse Laser, Small	Clan	F/X-X-E	NA / 3057P	30,000	1.5	1	1	1	1	1	1	1	1	1	1	1	
ER Pulse Laser, Medium	Clan	F/X-X-E	NA / 3057P	150,000	2	2	1	1	2	1	1	1	1	1	1	1	
ER Pulse Laser, Large	Clan	F/X-X-E	NA / 3057P	400,000	6	3	1	1	3	1	1	1	1	1	1	1	
Improved Heavy Laser, Small	Clan	F/X-X-F	NA / 3069P	30,000	0.5	1	1	1	1	1	1	1	1	1	1	1	
Improved Heavy Laser, Medium	Clan	F/X-X-F	NA / 3069P	150,000	1	2	1	1	2	1	1	1	1	1	1	1	
Improved Heavy Laser, Large	Clan	F/X-X-F	NA / 3069P	350,000	4	3	1	1	3	1	1	1	1	1	1	1	
Variable-Speed Laser, Small	IS	E/X-X-E	3070P / NA	60,000	2	1	NA	1	1	1	1	1	1	1	1	1	
Variable-Speed Laser, Medium	IS	E/X-X-E	3070P / NA	200,000	4	2	NA	1	2	1	1	1	1	1	1	1	
Variable-Speed Laser, Large	IS	E/X-X-E	3070P / NA	465,000	9	4	NA	1	4	1	1	1	1	1	1	1	
X-Pulse Laser, Small	IS	E/X-X-E	3057P / NA	31,000	1	1	NA	1	1	1	1	1	1	1	1	1	

\*See rules for this equipment in the *Advanced Weapons And Equipment* section, starting on p. 274.

Weapon/Item	Type S	Heat Std	Damage Std	Range	Ammo (per Ton)	To-Hit Modifier	TC Comp	Rules	Ref
		(Aero)	(Aero)	Min/Sht/Med/Lng (Aero)				Level	
X-Pulse Laser, Medium	P	6 (6)	6 (6)	0/3/6/9 (Short)	NA	-2	Y*	Exp	321
X-Pulse Laser, Large	P	14 (14)	9 (9)	0/5/10/15 (Medium)	NA	-2	Y*	Exp	321
Laser Anti-Missile System (IS)	PD	7 (7)	NA (NA)	NA (NA)	NA	NA	N	Exp	322
Laser Anti-Missile System (Clan)	PD	5 (5)	NA (NA)	NA (NA)	NA	NA	N	Exp	322
Laser Insulator	PE	-1** (-1**)	NA (NA)	NA (NA)	NA	NA	NA	Exp	322
Light Sail	PE	NA (NA)	NA (NA)	NA (NA)	NA	NA	NA	Adv	323
Lithium-Fusion Battery	PE	NA (NA)	NA (NA)	NA (NA)	NA	NA	NA	Adv	323
Mass Drivers									
Light Mass Driver	CAP, AE	NA (30)	NA (60-C)	NA (Long-C)	1/30	+2*	N	Exp	323
Medium Mass Driver	CAP, AE	NA (60)	NA (100-C)	NA (Long-C)	1/60	+2*	N	Exp	323
Heavy Mass Driver	CAP, AE	NA (90)	NA (140-C)	NA (Long-C)	1/90	+2*	N	Exp	323
'Mech Mortar/1 (IS)	M, C, S	1 (NA)	* (NA)	6/7/14/21 (NA)	24	+3*	N	Adv	324
'Mech Mortar/1 (Clan)	M, C, S	1 (NA)	* (NA)	6/7/14/21 (NA)	24	+3*	N	Adv	324
'Mech Mortar/2 (IS)	M, C, S	2 (NA)	* (NA)	6/7/14/21 (NA)	12	+3*	N	Adv	324
'Mech Mortar/2 (Clan)	M, C, S	2 (NA)	* (NA)	6/7/14/21 (NA)	12	+3*	N	Adv	324
'Mech Mortar/4 (IS)	M, C, S	5 (NA)	* (NA)	6/7/14/21 (NA)	6	+3*	N	Adv	324
'Mech Mortar/4 (Clan)	M, C, S	5 (NA)	* (NA)	6/7/14/21 (NA)	6	+3*	N	Adv	324
'Mech Mortar/8 (IS)	M, C, S	10 (NA)	* (NA)	6/7/14/21 (NA)	4	+3*	N	Adv	324
'Mech Mortar/8 (Clan)	M, C, S	10 (NA)	* (NA)	6/7/14/21 (NA)	4	+3*	N	Adv	324
MechWarrior Aquatic Survival System	PE	0 (NA)	NA (NA)	NA (NA)	NA	NA	NA	Exp	325
Mine Dispensers									
Vehicular (Land or Maritime)	PE	0 (0)	* (*)	—/—/—/0 (*)	2*	NA	NA	Adv	325
Space	PE	NA (0)	* (*)	NA (0)	2*	NA	NA	Adv	325
Minesweeper	PE	0 (NA)	* (NA)	NA (NA)	NA	NA	NA	Adv	326
Missile Launchers									
Enhanced LRM 5	M, C, S	2 (2)	1/Msl, C5/5 (3)	3/7/14/21 (Long)	24	0	N	Exp	326
Enhanced LRM 10	M, C, S	4 (4)	1/Msl, C5/10 (6)	3/7/14/21 (Long)	12	0	N	Exp	326
Enhanced LRM 15	M, C, S	5 (5)	1/Msl, C5/15 (9)	3/7/14/21 (Long)	8	0	N	Exp	326
Enhanced LRM 20	M, C, S	6 (6)	1/Msl, C5/20 (12)	3/7/14/21 (Long)	6	0	N	Exp	326
Extended LRM 5	M, C, S	3 (3)	1/Msl, C5/5 (3)	10/12/22/38 (Ext.)	18	0	N	Exp	327
Extended LRM 10	M, C, S	6 (6)	1/Msl, C5/10 (6)	10/12/22/38 (Ext.)	9	0	N	Exp	327
Extended LRM 15	M, C, S	8 (8)	1/Msl, C5/15 (9)	10/12/22/38 (Ext.)	6	0	N	Exp	327
Extended LRM 20	M, C, S	12 (12)	1/Msl, C5/20 (12)	10/12/22/38 (Ext.)	4	0	N	Exp	327
Improved One-Shot Launcher	PE	* (*)	* (*)	* (*)	OS	NA	NA	Adv	327
Streak LRM 5	M, C*	2 (2)	5 (5)	0/7/14/21 (Long)	24	0	N	Exp	327
Streak LRM 10	M, C*	4 (4)	10* (10)	0/7/14/21 (Long)	12	0	N	Exp	327
Streak LRM 15	M, C*	5 (5)	15* (15)	0/7/14/21 (Long)	8	0	N	Exp	327
Streak LRM 20	M, C*	6 (6)	20* (20)	0/7/14/21 (Long)	6	0	N	Exp	327
Streak LRM (ProtoMech, per tube)	M, C*	1 (NA)	1 (NA)	0/7/14/21 (NA)	120	0	N	Exp	327
Mobile Field Base	PE	NA (NA)	NA (NA)	NA (NA)	NA	NA	NA	Adv	330
Mobile Hyperpulse Generators									
Mobile HPG	PE	NA (NA)	NA (NA)	NA (NA)	NA	NA	NA	Adv	330
Ground-Mobile HPG	PE	NA (NA)	NA (NA)	NA (NA)	NA	NA	NA	Adv	330
M-Pod	PD, C, V, X	0 (NA)	15/10/5* (NA)	0/1/2/3 (NA)	OS	-1*	N	Adv	330
MRM "Apollo" FCS	E	0 (0)	* (*)	NA (NA)	NA	-1*	N	Adv	330
Naval (Capital) Autocannons									
NAC/10	CAP, AE	NA (30)	NA (10-C)	NA (Long-C)	5/1	0*	N	Adv	331
NAC/20	CAP, AE	NA (60)	NA (20-C)	NA (Long-C)	5/2	0*	N	Adv	331
NAC/25	CAP, AE	NA (85)	NA (25-C)	NA (Long-C)	5/3	0*	N	Adv	331
NAC/30	CAP, AE	NA (100)	NA (30-C)	NA (Long-C)	5/4	0*	N	Adv	331
NAC/35	CAP, AE	NA (120)	NA (35-C)	NA (Medium-C)	1	0*	N	Adv	331
NAC/40	CAP, AE	NA (135)	NA (40-C)	NA (Medium-C)	5/6	0*	N	Adv	331
Naval C <sup>3</sup>	CAP, E	NA (NA)	NA (NA)	NA (*)	NA	NA	NA	Exp	332
Naval Comm-Scanner Suites									
Small NCSS	CAP, E	NA (NA)	NA (NA)	NA (*)	NA	NA	NA	Adv	332
Large NCSS	CAP, E	NA (NA)	NA (NA)	NA (*)	NA	NA	NA	Adv	332
Naval (Capital) Gauss									
Light N-Gauss	CAP, AE	NA (9)	NA (15-C)	NA (Extreme-C)	5	0*	N	Adv	333
Medium N-Gauss	CAP, AE	NA (15)	NA (25-C)	NA (Extreme-C)	5/2	0*	N	Adv	333
Heavy N-Gauss	CAP, AE	NA (18)	NA (30-C)	NA (Extreme-C)	2	0*	N	Adv	333
Naval (Capital) Lasers									
NL35	CAP, AE	NA (52)	NA (3.5-C)	NA (Long-C)	NA	0*	N	Adv	333
NL45	CAP, AE	NA (70)	NA (4.5-C)	NA (Extreme-C)	NA	0*	N	Adv	333
NL55	CAP, AE	NA (85)	NA (5.5-C)	NA (Extreme-C)	NA	0*	N	Adv	333
Naval (Capital) PPCs									
Light N-PPC	CAP, AE	NA (105)	NA (7-C)	NA (Long-C)	NA	0*	N	Adv	333
Medium N-PPC	CAP, AE	NA (135)	NA (9-C)	NA (Extreme-C)	NA	0*	N	Adv	333
Heavy N-PPC	CAP, AE	NA (225)	NA (15-C)	NA (Extreme-C)	NA	0*	N	Adv	333
Naval Repair Facilities									
Unpressurized	PE	NA (NA)	NA (NA)	NA (NA)	NA	NA	NA	Adv	334
Pressurized	PE	NA (NA)	NA (NA)	NA (NA)	NA	NA	NA	Adv	334
Reinforced (Unpressurized)	PE	NA (NA)	NA (NA)	NA (NA)	NA	NA	NA	Exp	334
Naval Tug Adaptor	PE	NA (NA)	NA (NA)	NA (NA)	NA	NA	NA	Adv	334
Null-Signature System	E	10 (NA)	NA (NA)	NA (NA)	NA	NA	NA	Exp	336

\*See rules for this equipment in the *Advanced Weapons And Equipment* section, starting on p. 274.

Weapon/Item	Tech Base	Tech Rating	Latest Intro Date (IS / Clan)	Item / Ammo Cost (C-bills)	Weight (Tons)	Space §§											
						M	P	CV	SV	F	SC	DS	JS	WS	SS	MS	
X-Pulse Laser, Medium	IS	E/X-X-E	3057P / NA	110,000	2	1	NA	1	1	1	1	1	1	1	1	1	1
X-Pulse Laser, Large	IS	E/X-X-E	3057P / NA	275,000	7	2	NA	1	2	1	1	1	1	1	1	1	1
Laser Anti-Missile System (IS)	IS	E/X-X-E	3059P / NA	225,000	1.5	2	NA	1	2	1	1	1	1	1	1	1	1
Laser Anti-Missile System (Clan)	Clan	F/X-X-E	NA / 3048P	225,000	1	1	NA	1	1	1	1	1	1	1	1	1	1
Laser Insulator	IS/Clan	*	2575X / 2575X	3,000	+0.5**	+1**	NA	+1**	+1**	+1**	+1**	NA	NA	NA	NA	NA	NA
Light Sail	IS/Clan	C/C-E-D	2165 / 2165	100,000xIT	TT÷10*	NA	NA	NA	1*	NA	NA	NA	NA	NA	NA	NA	NA
Lithium-Fusion Battery	IS/Clan	*	3043 / 2531	3xKF	TT÷100*	NA	NA	NA	NA	NA	NA	NA	1	1	NA	NA	NA
Mass Drivers																	
Light Mass Driver	IS	D/X-X-F	2715P / NA	150M / 150,000	30,000	NA	NA	NA	NA	NA	NA	NA	NA	NA	1*	1*	NA
Medium Mass Driver	IS	D/X-X-F	2715P / NA	280M / 300,000	50,000	NA	NA	NA	NA	NA	NA	NA	NA	NA	1*	1*	NA
Heavy Mass Driver	IS	D/X-X-F	2715P / NA	500M / 600,000	100,000	NA	NA	NA	NA	NA	NA	NA	NA	NA	1*	1*	NA
'Mech Mortar/1 (IS)	IS	B/D-F-E	3043 / 2531X	7,000 / 10,000	2	1	NA	1	1	NA	NA	NA	NA	NA	NA	NA	1
'Mech Mortar/1 (Clan)	Clan	B/D-F-E	NA / 2840	7,000 / 10,000	1	1	NA	1	1	NA	NA	NA	NA	NA	NA	NA	1
'Mech Mortar/2 (IS)	IS	B/D-F-E	3043 / 2531X	15,000 / 10,000	5	2	NA	1	2	NA	NA	NA	NA	NA	NA	NA	1
'Mech Mortar/2 (Clan)	Clan	B/D-F-E	NA / 2840	15,000 / 10,000	2.5	1	NA	1	1	NA	NA	NA	NA	NA	NA	NA	1
'Mech Mortar/4 (IS)	IS	B/D-F-E	3043 / 2531X	32,000 / 10,000	7	3	NA	1	3	NA	NA	NA	NA	NA	NA	NA	1
'Mech Mortar/4 (Clan)	Clan	B/D-F-E	NA / 2840	32,000 / 10,000	3.5	2	NA	1	2	NA	NA	NA	NA	NA	NA	NA	1
'Mech Mortar/8 (IS)	IS	B/D-F-E	3043 / 2531X	70,000 / 10,000	10	5	NA	1	5	NA	NA	NA	NA	NA	NA	NA	1
'Mech Mortar/8 (Clan)	Clan	B/D-F-E	NA / 2840	70,000 / 10,000	5	3	NA	1	3	NA	NA	NA	NA	NA	NA	NA	1
MechWarrior Aquatic Survival System	IS/Clan	D/X-X-D	3048P / 3062P	4,000	1.5	1*	NA	NA	NA	NA	NA	NA	NA	NA	NA	NA	NA
Mine Dispensers																	
Vehicular (Land or Maritime)	IS/Clan	B/E-E-E	PS / PS	20,000 / 20,000	0.5	1	NA	1	1	1	1	1	1	NA	NA	NA	1
Space	IS/Clan	D/E-F-E	ES / ES	15,000 / 15,000	10	NA	NA	NA	1*	1*	1	1	1	1	1	1	NA
Minesweeper	IS/Clan	C/D-D-D	PS / PS	40,000	3	NA	NA	1*	1*	NA	NA	NA	NA	NA	NA	NA	1
Missile Launchers																	
Enhanced LRM-5 (NLRM 5)	IS	E/X-X-F	3058P / NA	37,500 / 31,000	3	2	NA	1	2	1	1	1	1	1	1	1	1
Enhanced LRM-10 (NLRM 10)	IS	E/X-X-F	3058P / NA	125,000 / 31,000	6	4	NA	1	4	1	1	1	1	1	1	1	1
Enhanced LRM-15 (NLRM 15)	IS	E/X-X-F	3058P / NA	157,000 / 31,000	9	6	NA	1	6	1	1	1	1	1	1	1	1
Enhanced LRM-20 (NLRM 20)	IS	E/X-X-F	3058P / NA	312,500 / 31,000	12	9	NA	1	9	1	1	1	1	1	1	1	1
Extended LRM-5 (ELRM 5)	IS	E/X-X-F	3054P / NA	60,000 / 35,000	6	1	NA	1	1	1	1	1	1	1	1	1	1
Extended LRM-10 (ELRM 10)	IS	E/X-X-F	3054P / NA	200,000 / 35,000	8	4	NA	1	4	1	1	1	1	1	1	1	1
Extended LRM-15 (ELRM 15)	IS	E/X-X-F	3054P / NA	350,000 / 35,000	12	6	NA	1	12	1	1	1	1	1	1	1	1
Extended LRM-20 (ELRM 20)	IS	E/X-X-F	3054P / NA	500,000 / 35,000	18	8	NA	1	18	1	1	1	1	1	1	1	1
Improved One-Shot Launcher	IS/Clan	B/X-X-F	3056 / 3058	0.8xIC	-0.5**	+0	+0	+0	+0	+0	+0	+0	+0	+0	+0	+0	+0
Streak LRM-5	Clan	F/X-X-F	NA / 3057P	75,000 / 60,000	2	1	NA	1	1	1	1	1	1	1	1	1	1
Streak LRM-10	Clan	F/X-X-F	NA / 3057P	225,000 / 60,000	5	2	NA	1	2	1	1	1	1	1	1	1	1
Streak LRM-15	Clan	F/X-X-F	NA / 3057P	400,000 / 60,000	7	3	NA	1	3	1	1	1	1	1	1	1	1
Streak LRM-20	Clan	F/X-X-F	NA / 3057P	600,000 / 60,000	10	5	NA	1	5	1	1	1	1	1	1	1	1
Streak LRM (ProtoMech, per tube)	Clan	F/X-X-F	NA / 3065P	15,000 / 60,000	0.4	NA	1*	NA	NA	NA	NA	NA	NA	NA	NA	NA	NA
Mobile Field Base	IS/Clan	D/X-X-E	3059 / 3060	150,000	20	NA	NA	1	1	NA	NA	NA	NA	NA	NA	NA	1
Mobile Hyperpulse Generators																	
Mobile HPG	IS/Clan	E/E-X-F	2655 / 2655	1,000,000,000	50	NA	NA	NA	50	NA	1	1	1	1	1	1	1
Ground-Mobile HPG	IS/Clan	F/F-X-F	2751 / 2751	4,000,000,000	12	12	NA	1	12	1	1	1	1	1	1	1	1
M-Pod	IS	C/X-X-E	3064 / NA	6,000	1	1	NA	1	1	NA	NA	NA	NA	NA	NA	NA	1
MRM "Apollo" FCS	IS	D/X-X-E	3071 / NA	125,000	+1**	+1**	NA	+0**	+1**	+0**	+0**	+0**	+0**	+0**	+0**	+0**	+0**
Naval (Capital) Autocannons																	
NAC/10	IS/Clan	D/E-X-E	2195 / 2195	2M / 30,000	2,000	NA	NA	NA	NA	NA	NA	NA	1-C*	1-C*	1-C*	1*	1*
NAC/20	IS/Clan	D/E-X-E	2197 / 2197	5M / 60,000	2,500	NA	NA	NA	NA	NA	NA	NA	1-C*	1-C*	1-C*	1*	1*
NAC/25	IS/Clan	D/E-X-E	2200 / 2200	7.5M / 75,000	3,000	NA	NA	NA	NA	NA	NA	NA	1-C*	1-C*	1-C*	1*	1*
NAC/30	IS/Clan	D/E-X-E	2200 / 2200	10.5M / 90,000	3,500	NA	NA	NA	NA	NA	NA	NA	1-C*	1-C*	1-C*	1*	1*
NAC/35	IS/Clan	D/E-X-E	2201 / 2201	14M / 105,000	4,000	NA	NA	NA	NA	NA	NA	NA	1-C*	1-C*	1-C*	1*	1*
NAC/40	IS/Clan	D/E-X-E	2202 / 2202	18M / 120,000	4,500	NA	NA	NA	NA	NA	NA	NA	1-C*	1-C*	1-C*	1*	1*
Naval C <sup>3</sup>	IS	F/X-X-F	3065P / NA	100,000xIT	*	NA	NA	NA	NA	NA	NA	0*	0*	0*	0*	0*	NA
Naval Comm-Scanner Suites																	
Small NCSS	IS/Clan	D/D-E-E	2200 / 2200	50,000,000	100	NA	NA	NA	NA	NA	0*	0*	0*	0*	0*	0*	NA
Large NCSS	IS/Clan	D/D-E-E	2200 / 2200	250,000,000	500	NA	NA	NA	NA	NA	0*	0*	0*	0*	0*	0*	NA
Naval (Capital) Gauss																	
Light N-Gauss	IS/Clan	*	2448 / 2448	20.3M / 45,000	4,500	NA	NA	NA	NA	NA	NA	NA	1-C*	1-C*	1-C*	1*	1*
Medium N-Gauss	IS/Clan	*	2448 / 2448	30.35M / 75,000	5,500	NA	NA	NA	NA	NA	NA	NA	1-C*	1-C*	1-C*	1*	1*
Heavy N-Gauss	IS/Clan	*	2449 / 2449	50.05M / 90,000	7,000	NA	NA	NA	NA	NA	NA	NA	1-C*	1-C*	1-C*	1*	1*
Naval (Capital) Lasers																	
NL35	IS/Clan	*	2305 / 2305	500,000	700	NA	NA	NA	NA	NA	NA	NA	1-C*	1-C*	1-C*	1*	1*
NL45	IS/Clan	*	2305 / 2305	850,000	900	NA	NA	NA	NA	NA	NA	NA	1-C*	1-C*	1-C*	1*	1*
NL55	IS/Clan	*	2307 / 2307	1,250,000	1,100	NA	NA	NA	NA	NA	NA	NA	1-C*	1-C*	1-C*	1*	1*
Naval (Capital) PPCs																	
Light N-PPC	IS/Clan	*	2358 / 2358	2,000,000	1,400	NA	NA	NA	NA	NA	NA	NA	1-C*	1-C*	1-C*	1*	1*
Medium N-PPC	IS/Clan	*	2358 / 2358	3,250,000	1,800	NA	NA	NA	NA	NA	NA	NA	1-C*	1-C*	1-C*	1*	1*
Heavy N-PPC	IS/Clan	*	2356 / 2356	9,050,000	3,000	NA	NA	NA	NA	NA	NA	NA	1-C*	1-C*	1-C*	1*	1*
Naval Repair Facilities																	
Unpressurized	IS/Clan	C/C-E-D	ES / ES	5,000xC	0.025xC	NA	NA	NA	NA	NA	NA	NA	0*	0*	0*	0*	NA
Pressurized	IS/Clan	C/C-E-D	ES / ES	10,000xC	0.075xC	NA	NA	NA	NA	NA	NA	NA	0*	0*	0*	0*	NA
Reinforced (Unpressurized)	IS	C/F-X-F	3065P / NA	30,000xC	0.010xC	NA	NA	NA	NA	NA	NA	NA	0*	0*	0*	0*	NA
Naval Tug Adaptor	IS/Clan	C/C-C-C	ES / ES	100,000	100*	NA	NA	NA	NA	NA	0*	0*	NA	0*	0*	NA	NA
Null-Signature System	IS	E/E-X-X	2630X / 2630X	1,400,000	0**	7*	NA	NA	NA	NA	NA	NA	NA	NA	NA	NA	NA

\*See rules for this equipment in the *Advanced Weapons And Equipment* section, starting on p. 274.

Weapon/Item	Type S	Heat Std	Damage Std	Range	Ammo	To-Hit	TC Comp	Rules	Ref
		(Aero)	(Aero)	Min/Sht/Med/Lng (Aero)	(per Ton)	Modifier		Level	
PCMT Equipment, Low-Density	PE	NA (NA)	NA (NA)	NA (NA)	NA	NA	NA	Adv	336
PPC Capacitor	PE	+5** (+5**)	+5** (+5**)	NA (NA)	NA	0	Y	Exp	337
ProtoMech Melee Weapon	ME	0 (NA)	Var** (NA)	Melee (NA)	NA	0	N	Exp	337
Recon Camera	E	NA (NA)	NA (NA)	* (*)	NA	NA	NA	Adv	337
Rifle (Cannon)									
Light Rifle	DB*	1 (1)	3 (3)*	0/4/8/12 (Medium)	18	NA	Y	Exp	338
Medium Rifle	DB*	2 (2)	6 (6)*	1/5/10/15 (Medium)	9	NA	Y	Exp	338
Heavy Rifle	DB*	4 (4)	9 (9)*	2/6/12/18 (Medium)	6	NA	Y	Exp	338
Satellite Imagers									
Hi-Res Imager	E	NA (NA)	NA (NA)	* (*)	NA	NA	NA	Adv	338
Hyperspectral Imager	E	NA (NA)	NA (NA)	* (*)	NA	NA	NA	Adv	338
Infrared Imager	E	NA (NA)	NA (NA)	* (*)	NA	NA	NA	Adv	339
Look-Down Radar	E	NA (NA)	NA (NA)	* (*)	NA	NA	NA	Adv	340
Structure									
Composite	Structure	NA (NA)	NA (NA)	NA (NA)	NA	NA	NA	Exp	342
Endo-Composite (Inner Sphere)	Structure	NA (NA)	NA (NA)	NA (NA)	NA	NA	NA	Exp	342
Endo-Composite (Clan)	Structure	NA (NA)	NA (NA)	NA (NA)	NA	NA	NA	Exp	342
Reinforced	Structure	NA (NA)	NA (NA)	NA (NA)	NA	NA	NA	Exp	342
Sub-Capital Cannons									
Light SCC	CAP, AE	12 (12)	20 (2-C)	* (Long-C)	2	0*	N	Adv	343
Medium SCC	CAP, AE	30 (30)	50 (5-C)	* (Medium-C)	1	0*	N	Adv	343
Heavy SCC	CAP, AE	42 (42)	70 (7-C)	* (Medium-C)	1/2	0*	N	Adv	343
Sub-Capital Lasers									
SCL/1	CAP, AE	24 (24)	10 (1-C)	* (Long-C)	NA	0*	N	Adv	343
SCL/2	CAP, AE	28 (28)	20 (2-C)	* (Medium-C)	NA	0*	N	Adv	343
SCL/3	CAP, AE	32 (32)	30 (3-C)	* (Medium-C)	NA	0*	N	Adv	343
Sub-Capital Missiles									
Piranha	CAP, AE	9 (9)	30 (3-C)	* (Long-C)	1/10	-1*	N	Adv	344
Stingray	CAP, AE	12 (12)	35 (3.5-C)	* (Medium-C)	3/50	0*	N	Adv	344
Swordfish	CAP, AE	15 (15)	40 (4-C)	* (Short-C)	1/120	0*	N	Adv	344
Manta Ray	CAP, AE	21 (21)	50 (5-C)	* (Short-C)	3/100	0*	N	Adv	344
Sub-Compact K-F Drive	CAP, PE	NA (NA)	NA (NA)	NA (NA)	NA	NA	NA	Exp	344
Supercharger	PE	NA (NA)	NA (NA)	NA (NA)	NA	NA	NA	Exp	345
Taser (BattleMech)	DB, X	6 (6)	1* (1*)	0/1/2/4 (NA)	5	+1	N	Exp	345
Thunderbolt Launcher									
Thunderbolt-5	M	3 (3)	5 (5)	5/6/12/18 (Medium)	12	NA	N	Adv	347
Thunderbolt-10	M	5 (5)	10 (10)	5/6/12/18 (Medium)	6	NA	N	Adv	347
Thunderbolt-15	M	7 (7)	15 (15)	5/6/12/18 (Medium)	4	NA	N	Adv	347
Thunderbolt-20	M	8 (8)	20 (20)	5/6/12/18 (Medium)	3	NA	N	Adv	347
Turrets									
BattleMech Turret (Shoulder)	PE	NA (NA)	NA (NA)	NA (NA)	NA	NA	NA	Exp	347
BattleMech Turret (Head)	PE	NA (NA)	NA (NA)	NA (NA)	NA	NA	NA	Exp	347
BattleMech Turret (Quad)	PE	NA (NA)	NA (NA)	NA (NA)	NA	NA	NA	Exp	347
Dual Turret (Vehicular)	PE	NA (NA)	NA (NA)	NA (NA)	NA	NA	NA	Exp	347
Sponson Turret (Vehicular)	PE	NA (NA)	NA (NA)	NA (NA)	NA	NA	NA	Exp	348
VTOL Chin Turret	PE	NA (NA)	NA (NA)	NA (NA)	NA	NA	NA	Exp	348
Vehicular DropChute (VDC)									
Standard VDC	PE	NA (NA)	NA (NA)	NA (NA)	NA	NA	NA	Adv	348
Camouflage VDC	PE	NA (NA)	NA (NA)	NA (NA)	NA	NA	NA	Adv	348
Stealth VDC	PE	NA (NA)	NA (NA)	NA (NA)	NA	NA	NA	Adv	348
Reusable VDC	PE	NA (NA)	NA (NA)	NA (NA)	NA	NA	NA	Adv	348
Vehicular Jump Jets	PE	NA (NA)	NA (NA)	NA (NA)	NA	NA	NA	Exp	349
Void-Signature System	E	10 (NA)	NA (NA)	NA (NA)	NA	NA	NA	Exp	349
VTOL Jet Booster	PE	NA (NA)	NA (NA)	NA (NA)	NA	NA	NA	Exp	350
VTOL Mast Mount	PE	NA (NA)	NA (NA)	NA (NA)	NA	NA	NA	Adv	350

\*See rules for this equipment in the *Advanced Weapons And Equipment* section, starting on p. 274.

NOTES

Damage and Range values noted with a “-C” reflect capital-scale damage and range brackets. Equivalent values without this notation reflect standard-scale damage and ranges. Damage values noted with an “A” reflect artillery weapon damage (see *Artillery*, p. 179).

To-hit modifiers reflect base to-hit from warrior/crew’s skill, not from “similar” attacks (such as the Chain Whip’s similarity to a Hatchet).

TC Comp reflects item’s compatibility with the Targeting Computer. If Y, item benefits from use of a Targeting Computer; if N, item cannot benefit from a Targeting Computer; if NA, Targeting Computer has no effect on item use.

§ WEAPON AND EQUIPMENT TYPES TABLE (EXPANDED)

- |                                    |   |
|------------------------------------|---|
| AE: Area-Effect Weapon             | M: Missile Weapon                             |
| AI: Anti-Infantry                  | ME: Melee-Enhancement Weapon                  |
| Armor: Armor System                | OS: One-Shot Weapon                           |
| C: Cluster Weapon                  | P: Pulse (Energy) Weapon                      |
| CAP: Capital-scale Weapon          | PD: Point-Blank System                        |
| CE: Counter-Electronics System     | PE: Physical Enhancement                      |
| DB: Direct-Fire (Ballistic) Weapon | R/C: Rapid-Fire (Multi-Firing)/Cluster Weapon |
| DE: Direct Fire (Energy) Weapon    | S: Switchable Ammo Supply                     |
| E: Electronics System              | Structure: Internal Structure System          |
| Engine: Engine System              | T: Targeting Enhancement System               |
| F: Flak                            | V: Variable-Damage                            |
| H: Heat-Causing Weapon             | X: Explosive Weapon/Component                 |

§§SPACE COLUMN ABBREVIATIONS TABLE

- |                                |                       |
|--------------------------------|-----------------------|
| M: BattleMechs/IndustrialMechs | SC: Small Craft       |
| P: ProtoMechs                  | DS: DropShips         |
| CV: Combat Vehicles            | JS: JumpShips         |
| SV: Support Vehicles           | WS: WarShips          |
| F: Fighters                    | SS: Space Stations    |
| (Conventional and Aerospace)   | MS: Mobile Structures |

Weapon/Item	Tech Base	Tech Rating	Latest Intro Date (IS / Clan)	Item / Ammo Cost (C-bills)	Weight (Tons)	Space §§											
						M	P	CV	SV	F	SC	DS	JS	WS	SS	MS	
PCMT Equipment, Low-Density	IS/Clan	C/C-C-C	2200 / 2200	200,000xIT	Var*	NA	NA	NA	1*	NA	NA	NA	NA	NA	NA	1*	NA
PPC Capacitor	IS	E/X-X-E	3060P / NA	150,000	+1**	+1**	NA	+0**	+1**	+0**	+0**	+0**	+0**	+0**	+0**	+0**	+0**
ProtoMech Melee Weapon	Clan	C/X-X-E	NA / 3067P	50,000	0.5*	NA	1*	NA	NA	NA	NA	NA	NA	NA	NA	NA	NA
Recon Camera	IS/Clan	C/B-B-B	PS / PS	10,000	0.5	1	1	1	1	1	1	1	NA	NA	NA	NA	NA
Rifle (Cannon)																	
Light Rifle	IS	B/C-F-X	PS / PS X	37,750 / 800	3	1	NA	1	1	1	1	1	NA	NA	NA	NA	1
Medium Rifle	IS	B/C-F-X	PS / PS X	75,500 / 1,000	5	2	NA	1	2	1	1	1	NA	NA	NA	NA	1
Heavy Rifle	IS	B/C-F-X	PS / PS X	90,000 / 3,000	8	3	NA	1	3	1	1	1	NA	NA	NA	NA	1
Satellite Imagers																	
Hi-Res Imager	IS/Clan	C/D-E-D	ES / ES	150,000	2.5	NA	NA	1*	1*	1	1	1	1	1	1	1	1*
Hyperspectral Imager	IS	D/X-X-F	3055 / NA	550,000	7.5	NA	NA	1*	2*	1	1	1	1	1	1	1	1*
Infrared Imager	IS/Clan	C/D-E-D	ES / ES	250,000	5	NA	NA	1*	1*	1	1	1	1	1	1	1	1*
Look-Down Radar	IS/Clan	B/D-E-D	ES / ES	400,000	5	NA	NA	1*	1*	1	1	1	1	1	1	1	1*
Structure																	
Composite	IS	E/X-X-E	3061P / NA	1,600xTT	TT±20	0	NA	NA	NA	NA	NA	NA	NA	NA	NA	NA	NA
Endo-Composite (Inner Sphere)	IS	E/X-X-F	3067P / NA	3,200xTT	TT±13.33	7	NA	NA	NA	NA	NA	NA	NA	NA	NA	NA	NA
Endo-Composite (Clan)	Clan	E/X-X-F	NA / 3073P	3,200xTT	TT±13.33	4	NA	NA	NA	NA	NA	NA	NA	NA	NA	NA	NA
Reinforced	IS/Clan	E/X-X-E	3057P / 3065P	6,400xTT	TT±5	0	NA	NA	NA	NA	NA	NA	NA	NA	NA	NA	NA
Sub-Capital Cannons																	
Light SCC	IS	E/X-X-F	3073 / NA	330,000 / 10,000	200	NA	NA	NA	30	NA	NA	1-C*	1-C*	1-C*	1-C*	1	
Medium SCC	IS	E/X-X-F	3073 / NA	780,000 / 18,000	500	NA	NA	NA	50	NA	NA	1-C*	1-C*	1-C*	1-C*	1	
Heavy SCC	IS	E/X-X-F	3073 / NA	1,300,000 / 25,000	700	NA	NA	NA	60	NA	NA	1-C*	1-C*	1-C*	1-C*	1	
Sub-Capital Lasers																	
SCL/1	IS	E/X-X-F	3073 / NA	220,000	150	NA	NA	NA	20	NA	NA	1-C*	1-C*	1-C*	1-C*	1	
SCL/2	IS	E/X-X-F	3073 / NA	335,000	200	NA	NA	NA	26	NA	NA	1-C*	1-C*	1-C*	1-C*	1	
SCL/3	IS	E/X-X-F	3073 / NA	450,000	250	NA	NA	NA	32	NA	NA	1-C*	1-C*	1-C*	1-C*	1	
Sub-Capital Missiles																	
Piranha	IS/Clan	E/X-X-F	3072 / 3073	75,000 / 15,000	100	NA	NA	NA	18	NA	NA	1-C*	1-C*	1-C*	1-C*	1	
Stingray	IS/Clan	E/X-X-F	3072 / 3073	85,000 / 19,000	125	NA	NA	NA	25	NA	NA	1-C*	1-C*	1-C*	1-C*	1	
Swordfish	IS/Clan	E/X-X-F	3072 / 3073	110,000 / 25,000	150	NA	NA	NA	30	NA	NA	1-C*	1-C*	1-C*	1-C*	1	
Manta Ray	IS/Clan	E/X-X-F	3072 / 3073	150,000 / 30,000	200	NA	NA	NA	38	NA	NA	1-C*	1-C*	1-C*	1-C*	1	
Sub-Compact K-F Drive	IS/Clan	F/F-X-F	2320 / 2320	16xKF	TT±2*	NA	NA	NA	NA	NA	NA	0*	NA	0*	NA	NA	
Supercharger	IS	C/F-F-F	ES / ES	10,000xER	ET±10	1	NA	1	1	NA	NA	NA	NA	NA	NA	NA	
Taser (BattleMech)	IS	E/X-X-F	3067P / NA	200,000 / 2,000	4	3	NA	1	3	NA	NA	NA	NA	NA	NA	1	
Thunderbolt Launcher																	
Thunderbolt-5	IS	E/X-X-F	3072 / NA	50,000 / 50,000	3	1	NA	1	1	1	1	1	1	1	1	1	
Thunderbolt-10	IS	E/X-X-F	3072 / NA	175,000 / 50,000	7	2	NA	1	2	1	1	1	1	1	1	1	
Thunderbolt-15	IS	E/X-X-F	3072 / NA	325,000 / 50,000	11	3	NA	1	3	1	1	1	1	1	1	1	
Thunderbolt-20	IS	E/X-X-F	3072 / NA	450,000 / 50,000	15	5	NA	1	5	1	1	1	1	1	1	1	
Turrets																	
BattleMech Turret (Shoulder)	IS/Clan	C/F-X-F	2450P / 2450P	10,000xIT	TE±10	1*	NA	NA	NA	NA	NA	NA	NA	NA	NA	NA	
BattleMech Turret (Head)	IS/Clan	C/F-X-F	2450P / 2450P	10,000xIT	TE±10	1*	NA	NA	NA	NA	NA	NA	NA	NA	NA	NA	
BattleMech Turret (Quad)	IS/Clan	C/F-X-F	2320P / 2320P	10,000xIT	TE±10	1*	NA	NA	NA	NA	NA	NA	NA	NA	NA	NA	
Dual Turret (Vehicular)	IS/Clan	B/F-X-F	PS P / PS P	5,000xIT	TE±10	NA	NA	0*	0*	NA	NA	NA	NA	NA	NA	NA	
Sponson Turret (Vehicular)	IS/Clan	B/F-X-F	PS P / PS P	4,000xIT##	TE±10##	NA	NA	0*	0*	NA	NA	NA	NA	NA	NA	NA	
VTOL Chin Turret	IS/Clan	B/F-F-F	PS P / PS P	5,000xIT	TE±10	NA	NA	0*	0*	NA	NA	NA	NA	NA	NA	NA	
Vehicular DropChute (VDC)																	
Standard VDC	IS/Clan	D/D-E-B	2351 / 2351	1,000	2*	0	0	0	0	NA	NA	NA	NA	NA	NA	NA	
Camouflage VDC	IS/Clan	D/D-E-C	2351 / 2351	3,000	2*	0	0	0	0	NA	NA	NA	NA	NA	NA	NA	
Stealth VDC	IS/Clan	D/E-F-D	2355 / 2355	5,000	2.2*	0	0	0	0	NA	NA	NA	NA	NA	NA	NA	
Reusable VDC	IS/Clan	E/F-F-E	2353 / 2353	2xIC	+0.5**	2**	1**	1**	2**	NA	NA	NA	NA	NA	NA	NA	
Vehicular Jump Jets	IS/Clan	E/E-X-F	2650X / 2650X	†	Var*	*	NA	NA	1*	1*	NA	NA	NA	NA	NA	NA	
Void-Signature System	IS	E/X-X-E	3070P / NA	2,000,000	0*	7*	NA	NA	NA	NA	NA	NA	NA	NA	NA	NA	
VTOL Jet Booster	IS/Clan	D/X-F-E	3009 / ES	10,000xER	ET±10	NA	NA	1*	1*	NA	NA	NA	NA	NA	NA	NA	
VTOL Mast Mount	IS/Clan	C/F-F-F	PS / PS	50,000	0.5	NA	NA	0*	0*	NA	NA	NA	NA	NA	NA	NA	

\*See rules for this equipment in the *Advanced Weapons And Equipment* section, starting on p. 274.

\*\*Adds to existing weapon (see Special Rules)

†Jump Booster Cost = 150 x (Unit Tonnage) x (Jump MP x Jump MP); UMU costs = 200 x (Unit Tonnage) x (Number of UMUs x Number of UMUs); Vehicle Jump Jet costs = 200 x (Unit Tonnage) x (Jump MP x Jump MP)

‡An additional 5,000 C-bills must be applied to reflect the drone's sensors

‡‡Includes costs for all weapons and items placed in the mount

##Sponson Turret costs and weights are for two sponsons together. See special rules for this equipment.

NOTES

Introduction Dates marked with a "P" indicate Prototype Production only. Introduction Dates marked with an "X" indicate items that have since become extinct and not recovered. Clan dates prior to 2820 indicate Star League-era equipment

If a single value or formula appears for cost, the item has no ammunition cost; otherwise, the value left of the slash is the item cost and the value right of the slash equals the cost per ton of the weapon's standard ammunition

WEIGHT AND COST FORMULA CODES

"AT" = Armor Tonnage; "C" = Desired Capacity (in tons); "CS" = Critical Slots; "ER" = Engine Rating; "ET" = Engine Tonnage; "HX" = Number of Hexes item occupies; "IC" = Component Cost (based on item being modified); "IT" = Item Tonnage (weight of component itself); "KF" = Cost of all K-F Drive components together; "TC" = Total Unit Cost (in C-bills, applied to final calculations); "TE" = Turret Equipment Tonnage; "TT" = Total Unit Tonnage

## BATTLE ARMOR COMBAT DATA

Weapon/Item	Type	Damage Value	Range Min/Sht/Med/Lng	Modifier	To-Hit Level	Rules Ref
BA Mechanical Jump Boosters	PE	NA	NA	NA	Exp	286
BA Myomer Booster	PE	+2*	NA	NA	Exp	287
BA Detachable Weapon Pack	PE	As Weapon*	As Weapon*	0	Adv	287
BA C <sup>3</sup> System (per Trooper)	E	NA	NA	NA	Exp	297
BA C <sup>3</sup> i System (per Trooper)	E	NA	NA	NA	Exp	297
Disposable Weapon	PE	As Weapon*	As Weapon*	0	Adv	304
Lasers						
ER Pulse Laser, Small	P	3	0/1/2/4	-1	Exp	320
ER Pulse Laser, Medium	P	6	0/5/9/14	-1	Exp	320
Variable-Speed Laser, Small	P, AI	5/4/3*	0/2/4/6	Var*	Adv	321
Variable-Speed Laser, Medium	P, AI	9/7/5*	0/2/5/9	Var*	Adv	321
Mine Dispenser	PE	*	*	NA	Adv	325
Taser (Battle Armor)	DB	1*	0/1/2/3	+1	Adv	346
Vehicular DropChute (VDC)						
Standard VDC	PE	NA	NA	NA	Adv	348
Camouflage VDC	PE	NA	NA	NA	Adv	348
Stealth VDC	PE	NA	NA	NA	Adv	348
Reusable VDC	PE	NA	NA	NA	Adv	348

\*See rules for this equipment in the *Advanced Weapons And Equipment* section, starting on p. 274.

## CONVENTIONAL INFANTRY COMBAT DATA

Weapon/Item	Type	Damage Value	Range Min/Sht/Med/Lng	Modifier	To-Hit Level	Rules Ref
Beast-Mounted Infantry	PE	Var*	Var*	NA	Adv	295
Disposable Weapons	As Weapon*	As Weapon*	As Weapon*	As Weapon*	Adv	304
Field Guns	As Weapon*	As Weapon*	As Weapon*	As Weapon*	Adv	311
Field Artillery	As Weapon*	As Weapon*	As Weapon*	As Weapon*	Adv	311
Infantry Armor	Armor	NA	NA	NA	Adv	317
Mechanized VTOL Infantry						
Microlite VTOLs	PE	NA	NA	NA	Adv	324
Micro-copter VTOLs	PE	NA	NA	NA	Adv	324
Specialized Infantry						
Combat Engineers	PE	NA	NA	NA	Adv	340
Marines	PE	NA	NA	NA	Adv	341
Mountain Troops	PE	NA	NA	NA	Adv	341
Paramedics	PE	NA	NA	NA	Adv	341
Paratroops	PE	NA	NA	NA	Adv	341
SCUBA (Standard)	PE	NA	NA	NA	Adv	341
SCUBA (Motorized)	PE	NA	NA	NA	Adv	341
Xenoplanetary Condition-Trained Troops	PE	NA	NA	NA	Adv	351

\*See rules for this equipment in the *Advanced Weapons And Equipment* section, starting on p. 274.

## HEAVY WEAPONS AMMUNITION COMBAT DATA

Ammunition Type	Used By (Weapon)§	Damage Type	Damage Std (Aero)	Range Min/Sht/Med/Lng (Aero)	Ammo (per Ton)	To-Hit Modifier	Rules Level	Ref
Autocannons								
Caseless	SAC, LAC	DB	* (*)	* (*)	x2	+0	Exp	352
Flak	SAC, LAC	DB, F	** (**)	* (*)	x1	+0	Adv	352
Tracer	SAC, LAC	DB	** (**)	* (*)	x1	+0	Adv	353
Artillery								
Air-Defense Arrow (ADA)	AIV	F	20 (NA)	** (NA)	x1	+0	Exp	353
Arrow IV (Homing)	AIV	AE	20 (NA)	* (NA)	x1	+0**	Adv	353
Arrow IV (Non-Homing)	AIV	AE, F	20A (NA)	* (NA)	x1	+0	Adv	354
Arrow IV (Cluster)	AIV	AE, F	20A** (NA)	* (NA)	x1	+0	Adv	354
Cluster (Long Tom)	LAW	AE, F	20A** (NA)	* (NA)	x1	+0	Adv	354
Cluster (Sniper)	SAW	AE, F	15A** (NA)	* (NA)	x1	+0	Adv	354
Cluster (Thumper)	TAW	AE, F	10A** (NA)	* (NA)	x1	+0	Adv	354
Copperhead (Long Tom)	LAW	AE	15** (NA)	* (NA)	x1	+0**	Adv	355
Copperhead (Sniper)	SAW	AE	10** (NA)	* (NA)	x1	+0**	Adv	355

\*See rules for this equipment in the *Advanced Weapons And Equipment* section, starting on p. 274.

## BATTLE ARMOR CONSTRUCTION DATA

Weapon/Item	Tech Base	Tech Rating	Latest Intro Date (IS / Clan)	Item / Ammo Cost (C-bills)	WT (kg)	Space
BA Mechanical Jump Boosters	IS	E/X-X-F	3070P / NA	As Jump Jet*	2 x Jump Jet**	0
BA Myomer Booster	Clan	F/X-X-F	NA / 3072P	75,000xGround MP	250	3
BA Detachable Weapon Pack	IS / Clan	E/X-X-F	3073 / 3072	+18,000†	0.75 x Weapon/Ammo**	1
BA C <sup>3</sup> System (per Trooper)	IS	E/X-X-E	3073P / NA	62,500	250	1
BA C <sup>3</sup> i System (per Trooper)	IS	E/X-X-E	3063P / NA	125,000	350	1
Disposable Weapon	As Weapon**	As Weapon**	As Weapon**	As Weapon**	As Weapon**	**
Lasers						
ER Pulse Laser, Small	Clan	F/X-X-E	NA / 3059P	30,000 / 200	550	2
ER Pulse Laser, Medium	Clan	F/X-X-E	NA / 3059P	150,000 / 200	800	4
Variable-Speed Laser, Small	IS	E/X-X-E	3071 / NA	60,000 / 200	500	2
Variable-Speed Laser, Medium	IS	E/X-X-E	3072 / NA	200,000 / 200	900	4
Mine Dispenser	IS / Clan	D/X-X-E	3050 / 3058	20,000 / 5,000	50	2
Taser (Battle Armor)	IS	E/X-X-E	3067 / NA	10,000 / 500	300	3
Vehicular DropChute (VDC)						
Standard VDC	IS / Clan	D/D-E-B	3051 / 2875	1,000	200	0**
Camouflage VDC	IS / Clan	D/D-E-C	3051 / 2875	3,000	200	0*
Stealth VDC	IS / Clan	D/E-F-D	3054 / 2880	5,000	225	0*
Reusable VDC	IS / Clan	E/F-F-E	3053 / 2876	2xVDC Cost	+50†	1

\*Battle Armor Mechanical Jump Boosters cost the same amount as jump jets on a battlesuit of the same weight class. Adds to existing weapon (see Special Rules)

\*\*See rules for this equipment in the *Advanced Weapons And Equipment* section, starting on p. 274. † In addition to the weapon.

## INFANTRY CONSTRUCTION DATA

Weapon/Item	Tech Base	Tech Rating	Latest Intro Date (IS / Clan)	Cost (C-bills)	WT (kg)	Space
Beast-Mounted Infantry	IS / Clan	Var*	ES / ES	5,000xTT	Var*	NA
Disposable Weapons	IS / Clan	As Weapon*	As Weapon*	As Weapon*	As Weapon*	NA
Field Guns	IS / Clan	As Weapon*	As Weapon*	As Weapon*	As Weapon*	NA
Field Artillery	IS / Clan	As Weapon*	As Weapon*	As Weapon*	As Weapon*	NA
Infantry Armor	Var*	Var*	Var* / Var*	Var*	NA	NA
Mechanized VTOL Infantry						
Microlite VTOLs	IS / Clan	Var*	ES / ES	TCx4	+1.4/trooper	NA
Micro-copter VTOLs	IS / Clan	Var*	ES / ES	TCx4.5	+1.9/trooper	NA
Specialized Infantry						
Combat Engineers	IS / Clan	Var*	PS / PS	TCx5	+0.1/trooper	NA
Marines	IS / Clan	Var*	ES / ES	TCx3	+0/trooper	NA
Mountain Troops	IS / Clan	Var*	PS / PS	TCx2	+0/trooper	NA
Paramedics	IS / Clan	Var*	PS / PS	TCx0.375**	+0.05/trooper	NA
Paratroops	IS / Clan	Var*	PS / PS	TCx3	+0.05/trooper	NA
SCUBA (Standard)	IS / Clan	Var*	PS / PS	TCx2	+0.05/trooper	NA
SCUBA (Motorized)	IS / Clan	Var*	PS / PS	TCx2.5	+0.1/trooper	NA
Xenoplanetary Condition-Trained Troops	IS / Clan	Var*	Var* / Var*	TCx1.5	NA	NA

\*See rules for this equipment in the *Advanced Weapons And Equipment* section, starting on p. 274.

NOTE: "TT" = Total Unit Tonnage; "TC" Total Unit Cost (in C-bills, applied to final calculations)

\*\*Cost is per medic, added to the total platoon cost after finalizing calculations

## HEAVY WEAPONS AMMUNITION CONSTRUCTION DATA

Weapon/Item	Tech Base	Tech Rating	Latest Intro Date (IS / Clan)	Cost (C-bills)	Ammo (per Ton)	WT (Tons)
Autocannons						
Caseless	IS	D/X-X-E	3056P / NA	x1.5	x2	x1
Flak	IS / Clan	B/E-F-F	2310 / 2310	x1.5	x1	x1
Tracer	IS / Clan	B/D-E-F	2300 / 2300	x1.5	x1	x1
Artillery						
Air-Defense Arrow (ADA)	IS	E/X-X-F	3068P / NA	45,000	x1	x1
Arrow IV (Homing)	IS / Clan	E/E-F-E	3045 / 2600	15,000	x1	x1
Arrow IV (Non-Homing)	IS / Clan	E/E-F-E	3044 / 2600	10,000	x1	x1
Arrow IV (Cluster)	IS / Clan	E/E-F-E	3047 / 2620	x1.5	x1	x1
Cluster (Long Tom)	IS / Clan	E/E-F-E	PS / PS	x1.5	x1	x1
Cluster (Sniper)	IS / Clan	E/E-F-E	PS / PS	x1.5	x1	x1
Cluster (Thumper)	IS / Clan	E/E-F-E	PS / PS	x1.5	x1	x1
Copperhead (Long Tom)	IS / Clan	E/E-F-F	3051 / 2645	x1.5	x1	x1
Copperhead (Sniper)	IS / Clan	E/E-F-F	3051 / 2645	x1.5	x1	x1

\*See rules for this equipment in the *Advanced Weapons And Equipment* section, starting on p. 274.

Ammunition Type	Used By	Damage Type	Damage Std	Range	Ammo (per Ton)	To-Hit Modifier	Rules Level	Ref
	(Weapon)s		(Aero)	Min/Sht/Med/Lng (Aero)				
Copperhead (Thumper)	TAW	AE	5** (NA)	* (NA)	x1	+0**	Adv	355
Flechette	SAT	AE, AI	** (NA)	* (NA)	x1	+0	Adv	355
Arrow IV (Illumination)	AIV	*	** (NA)	* (NA)	x1	+0	Adv	355
Illumination	SAT	*	** (NA)	* (NA)	x1	+0	Adv	355
Arrow IV (Laser-Inhibiting)	AIV	*	0** (NA)	* (NA)	x0.5	+0	Exp	356
Inferno-IV	AIV	AE, H, AI	** (NA)	* (NA)	x1	+0	Adv	356
Arrow IV (Smoke)	AIV, SAT	AE	0** (NA)	* (NA)	x1	+0	Adv	356
Smoke	AIV, SAT	AE	0** (NA)	* (NA)	x1	+0	Adv	356
Thunder (FASCAM) (IS)	AIV, SAT	AE	0** (NA)	* (NA)	x1	+0	Adv	357
Thunder (FASCAM) (Clan)	AIV, SAT	AE	0** (NA)	* (NA)	x1	+0	Adv	357
Thunder Active-IV	AIV	AE	0** (NA)	* (NA)	x1	+0	Adv	357
Thunder Vibrabomb-IV	AIV	AE	0** (NA)	* (NA)	x1	+0	Adv	357
<b>Bombs</b>								
Air-to-Air (AAA) Arrow	EO (5)	M	NA (20)	NA (Medium)	1	+0**	Adv	357
Anti-Ship (AS) Missile	EO (6)	M	NA (30)	NA (Long)	0.5	+0**	Exp	358
Anti-Ship EW (ASEW) Missile	EO (6)	M, E	NA (**)	NA (Medium)	0.5	+0**	Adv	358
Arrow IV Homing Missile (Air Launch)	EO (5)	AE	NA (**)	NA (**)	1	+0**	Adv	358
Arrow IV Non-Homing Missile (Air Launch)	EO (5)	AE	NA (**)	NA (**)	1	+0	Adv	359
Inferno	EO (1)	AE, H	NA (**)	NA (**)	1	+0	Adv	359
Light Air-to-Air (LAA) Missile	EO (2)	M	NA (6)	NA (Medium)	2	+0**	Adv	359
Thunder (FASCAM) (IS)	EO (1)	AE	0** (NA)	* (NA)	1	+0	Adv	360
Thunder (FASCAM) (Clan)	EO (1)	AE	0** (NA)	* (NA)	1	+0	Adv	360
Thunder Active	EO (1)	AE	0** (NA)	* (NA)	1	+0	Adv	360
Thunder Vibrabomb	EO (1)	AE	0** (NA)	* (NA)	1	+0	Adv	360
Torpedo	EO (1)	DB	0** (10)	* (NA)	1	+0	Adv	360
<b>Flamer/Fluid Gun</b>								
Coolant	VFL, FLG, SPR	DB	** (**)	* (*)	x1	+0	Adv	361
Corrosive	FLG, SPR	DE, AI	** (**)	* (*)	x1	+0	Adv	361
Flame-Retardant Foam	FLG, SPR	DE	** (**)	* (*)	x1	+0	Adv	361
Inferno Fuel	VFL, FLG	DE, H, AI	** (**)	* (*)	x1	+0	Adv	361
Oil Slick	FLG, SPR	DE	** (**)	* (*)	x1	+0	Adv	362
Paint/Obscurant	FLG, SPR	DE, E	** (**)	* (*)	x1	+0	Adv	362
Water	VFL, FLG, SPR	DE, AI	** (**)	* (*)	x1	+0	Adv	362
<b>Grenade Launcher (Vehicular)</b>								
Chaff	VGL	AE, E	** (**)	* (*)	x1	NA	Adv	363
Fragmentation	VGL	AE, AI	** (**)	* (*)	x1	NA	Adv	363
Incendiary	VGL	AE, H, AI	** (**)	* (*)	x1	NA	Adv	364
Smoke	VGL	AE	** (**)	* (*)	x1	NA	Adv	364
<b>Mines</b>								
Active	LMN**	C	** (**)	** (**)	**	NA	Adv	364
Command-Detonated	LMN, MMN**	C	** (**)	** (**)	**	NA	Adv	365
EMP (Command-Detonated)	LMN**	E, AI	** (**)	** (**)	**	NA	Exp	365
EMP (Vibrabomb)	LMN**	E, AI	** (**)	** (**)	**	NA	Exp	365
Inferno	LMN, MMN**	C, H	** (**)	** (**)	**	NA	Adv	366
Space	SMN**	C	** (**)	** (**)	**	NA	Adv	366
Standard	LMN, MMN**	C	** (**)	** (**)	**	NA	Adv	367
Vibrabomb	LMN, MMN**	C	** (**)	** (**)	**	NA	Adv	367
<b>Missiles</b>								
Acid (AX) SRMs	SRM, MML	M, C	** (**)	0/3/6/9 (Short)	x0.5	+0**	Exp	367
Anti-Radiation (ARAD) SRMs	SRM, MML	M, C, E	** (**)	0/3/6/9 (Short)	x1	Var**	Exp	368
Anti-Radiation (ARAD) LRMs (IS)	LRM, MML	M, C, E	** (**)	6/7/14/21 (Long)	x1	Var**	Exp	368
Anti-Radiation (ARAD) LRMs (Clan)	LRM	M, C, E	** (**)	0/7/14/21 (Long)	x1	Var**	Exp	368
Artemis V Capable	LRM, SRM	M, C	** (**)	* (*)	x1	**	Exp	283
Bola Pods	NMB	* (*)	** (**)	0/3/6/9 (Short)	x1	+1	Exp	368
Follow-the-Leader (FTL) LRMs	LRM, MML	* (*)	** (**)	6/7/14/21 (Long)	x0.5	+2**	Exp	368
Harpoon SRMs	SRM, MML	* (*)	** (**)	0/3/6/9 (Short)	x1	+0	Adv	369
Heat-Seeking (HS) SRMs	SRM, MML	* (*)	** (**)	0/3/6/9 (Short)	x0.5	Var**	Adv	369
Heat-Seeking (HS) LRMs (IS)	LRM, MML	* (*)	** (**)	6/7/14/21 (Long)	x0.5	Var**	Adv	369
Heat-Seeking (HS) LRMs (Clan)	LRM	* (*)	** (**)	0/7/14/21 (Long)	x0.5	Var**	Adv	369
Incendiary LRMs (IS)	LRM, MML	* (*)	** (**)	6/7/14/21 (Long)	x1	+0	Adv	369
Incendiary LRMs (Clan)	LRM	* (*)	** (**)	0/7/14/21 (Long)	x1	+0	Adv	369
Magnetic-Pulse SRMs	SRM, MML	* (*)	** (**)	0/3/6/9 (Short)	x1	+0	Exp	370
Magnetic-Pulse LRMs	LRM, MML	* (*)	** (**)	6/7/14/21 (Long)	x1	+0	Exp	370
Mine-Clearance SRMs	SRM, MML	* (*)	** (**)	0/3/6/9 (Short)	x1	+0	Adv	370

\*See rules for this equipment in the *Advanced Weapons And Equipment* section, starting on p. 274.

Weapon/Item	Tech Base	Tech Rating	Latest Intro Date (IS / Clan)	Cost (C-bills)	Ammo (per Ton)	WT (Tons)
Copperhead (Thumper)	IS / Clan	E/E-F-F	3051 / 2645	x1.5	x1	x1
Flechette	IS / Clan	E/F-F-E	PS / PS	x1.5	x1	x1
Arrow IV (Illumination)	IS / Clan	C/D-D-D	3047 / 2621	x0.5	x1	x1
Illumination	IS / Clan	C/D-D-D	PS / PS	x0.5	x1	x1
Arrow IV (Laser-Inhibiting)	IS	E/X-X-F	3053P / NA	x4	x0.5	x1
Inferno-IV	IS	C/X-X-D	3055 / NA	x1	x1	x1
Arrow IV (Smoke)	IS / Clan	B/E-F-E	3044 / 2600	x0.5	x1	x1
Smoke	IS / Clan	B/A-A-A	PS / PS	x0.5	x1	x1
Thunder (FASCAM) (IS)	IS	C/E-X-E	3051 / 2621X	x1.5	x1	x1
Thunder (FASCAM) (Clan)	Clan	C/X-D-D	NA / 2621	x1.5	x1	x1
Thunder Active-IV	IS	D/X-X-E	3065 / NA	x3	x1	x1
Thunder Vibrabomb-IV	IS	D/X-X-E	3065 / NA	x2	x1	x1
<b>Bombs</b>						
Air-to-Air (AAA)Arrow	IS / Clan	E/X-X-F	3072 / 3072	9,000†	NA	1
Anti-Ship (AS) Missile	IS	D/X-X-F	3071P / NA	15,000†	NA	2
Anti-Ship EW (ASEW) Missile	IS	E/X-X-E	3067P / NA	20,000†	NA	2
Arrow IV Homing Missile (Air Launch)	IS / Clan	E/E-F-E	3047 / 2600	3,000†	NA	1
Arrow IV Non-Homing Missile (Air Launch)	IS / Clan	E/E-F-E	3046 / 2623	2,000†	NA	1
Inferno	IS / Clan	B/D-D-D	PS / PS	6,000†	NA	1
Light Air-to-Air (LAA) Missile	IS / Clan	E/X-X-F	3072 / 3074	6,000†	NA	0.5
Thunder (FASCAM) (IS)	IS	C/E-X-E	3052 / NA	12,000†	NA	1
Thunder (FASCAM) (Clan)	Clan	C/X-D-D	NA / 2623	12,000†	NA	1
Thunder Active	IS	D/X-X-E	3065 / NA	36,000†	NA	1
Thunder Vibrabomb	IS	D/X-X-E	3065 / NA	24,000†	NA	1
Torpedo	IS / Clan	B/C-C-C	PS / PS	7,000†	NA	1
<b>Flamer/Fluid Gun</b>						
Coolant	IS / Clan	C/B-B-B	ES / ES	3,000	x1	x1
Corrosive	IS / Clan	C/C-D-D	PS / PS	5,000	x1	x1
Flame-Retardant Foam	IS / Clan	B/B-B-B	PS / PS	1,000	x1	x1
Inferno Fuel	IS / Clan	D/D-E-D	2400 / 2400	2,000	x1	x1
Oil Slick	IS / Clan	B/B-B-B	PS / PS	2,000	x1	x1
Paint/Obscurant	IS / Clan	B/B-B-B	ES / ES	1,000	x1	x1
Water	IS / Clan	A/A-A-A	PS / PS	500	x1	x1
<b>Grenade Launcher (Vehicular)</b>						
Chaff	IS / Clan	B/X-X-E	3052 / 3065	—	x1	x1
Fragmentation	IS / Clan	B/B-B-B	PS / PS	—	x1	x1
Incendiary	IS / Clan	B/B-B-B	PS / PS	—	x1	x1
Smoke	IS / Clan	A/B-B-B	PS / PS	—	x1	x1
<b>Mines</b>						
Active	IS / Clan	D/X-X-E	ES / ES	20,000	**	**
Command-Detonated	IS / Clan	B/C-D-C	PS / PS	7,500	**	**
EMP (Command-Detonated)	IS / Clan	E/X-X-F	3065 / 3074	90,000	**	**
EMP (Vibrabomb)	IS / Clan	E/F-X-F	3058 / 2680	100,000	**	**
Inferno	IS / Clan	C/X-X-D	3055 / 3065	5,000	**	**
Space	IS / Clan	C/E-F-E	ES / ES	1,500	0.1	10
Standard	IS / Clan	B/C-C-C	PS / PS	5,000	**	**
Vibrabomb	IS / Clan	C/E-E-D	2445 / 2445	10,000	**	**
<b>Missiles</b>						
Acid (AX) SRMs	IS	E/X-X-F	3053P / NA	x2	x0.5	x1
Anti-Radiation (ARAD) SRMs	IS / Clan	E/X-X-E	3066P / 3057P	x3	x1	x1
Anti-Radiation LRMs (ARAD) (IS)	IS	E/X-X-E	3066P / NA	x3	x1	x1
Anti-Radiation LRMs (ARAD) (Clan)	Clan	E/X-X-E	NA / 3057P	x3	x1	x1
Artemis V Capable	Clan	F/X-X-F	NA / 3061P	x5	x1	x1
Bola Pods	IS	D/X-X-E	3056P / NA	2,000	x1	x1
Follow-the-Leader (FTL) LRMs	IS / Clan	E/F-X-E	3053P / 2755P	x2	x0.5	x1
Harpoon SRMs	IS / Clan	C/C-C-C	2400 / 2400	x2	x1	x1
Heat-Seeking (HS) SRMs	IS / Clan	C/E-E-E	2340 / 2340	x2	x0.5	x1
Heat-Seeking (HS) LRMs (IS)	IS	C/E-E-E	2340 / 2340	x2	x0.5	x1
Heat-Seeking (HS) LRMs (Clan)	Clan	C/E-E-E	2340 / 2340	x2	x0.5	x1
Incendiary LRMs (IS)	IS / Clan	C/E-X-E	2342 / 2341X	x1.5	x1	x1
Incendiary LRMs (Clan)	Clan	D/X-E-E	NA / 2825	x1.5	x1	x1
Magnetic-Pulse SRMs	IS	E/X-X-F	3057X / NA	x5	x1	x1
Magnetic-Pulse LRMs	IS	E/X-X-F	3057X / NA	x5	x1	x1
Mine-Clearance SRMs	IS	C/X-X-E	3069 / NA	x4	x1	x1

\*See rules for this equipment in the *Advanced Weapons And Equipment* section, starting on p. 274.

Ammunition Type	Used By	Damage Type	Damage Std (Aero)	Range	Ammo (per Ton)	To-Hit Modifier	Rules Level	Ref
	(Weapon)§			(Min/Sht/Med/Lng (Aero))				
Mine-Clearance LRMs	LRM, MML	* (*)	** (**)	6/7/14/21 (Long)	x1	+0	Adv	370
Smoke SRMs	SRM, MML	* (*)	** (**)	0/3/6/9 (Short)	x1	+0	Adv	371
Smoke LRMs (IS)	LRM, MML	* (*)	** (**)	6/7/14/21 (Long)	x1	+0	Adv	371
Smoke LRMs (Clan)	LRM	* (*)	** (**)	0/7/14/21 (Long)	x1	+0	Adv	371
Swarm LRMs (IS)	LRM, MML	* (*)	** (**)	6/7/14/21 (Long)	x1	+0**	Adv	371
Swarm LRMs (Clan)	LRM	* (*)	** (**)	0/7/14/21 (Long)	x1	+0**	Adv	371
Swarm-I LRMs	LRM, MML	* (*)	** (**)	6/7/14/21 (Long)	x1	+0**	Adv	371
Tandem-Charge SRMs	SRM, MML	* (*)	** (**)	0/3/6/9 (Short)	x0.5	+0	Exp	372
Tear Gas SRMs	SRM, MML	* (*)	** (**)	0/3/6/9 (Short)	x1	+0	Adv	372
Thunder LRMs (IS)	LRM, MML	* (*)	** (**)	6/7/14/21 (Long)	x1	+0	Adv	373
Thunder LRMs (Clan)	LRM	* (*)	** (**)	0/7/14/21 (Long)	x1	+0	Adv	373
Thunder-Active LRMs	LRM, MML	* (*)	** (**)	6/7/14/21 (Long)	x1	+0	Adv	373
Thunder-Augmented LRMs	LRM, MML	* (*)	** (**)	6/7/14/21 (Long)	x1	+0	Adv	373
Thunder-Inferno LRMs	LRM, MML	* (*)	** (**)	6/7/14/21 (Long)	x1	+0	Adv	373
Thunder-Vibrobomb LRMs	LRM, MML	* (*)	** (**)	6/7/14/21 (Long)	x1	+0	Adv	373
<b>'Mech Mortars</b>								
Airburst	MMR	M, C, AE, AI	** (**)	6/7/14/21 (Long)	x1	+0	Adv	373
Anti-Personnel	MMR	M, C, AI	** (**)	6/7/14/21 (Long)	x1	+0	Adv	373
Armor Piercing (Shaped Charge)	MMR	M, C	** (**)	6/7/14/21 (Long)	x1	+0	Adv	374
Flare	MMR	M, AE	** (**)	6/7/14/21 (Long)	x1	+0	Adv	374
Semi-Guided	MMR	M, C	** (**)	6/7/14/21 (Long)	x1	+0**	Adv	374
Smoke	MMR	M, AE	** (**)	6/7/14/21 (Long)	x1	+0	Adv	375
Remote Sensors	**	E	** (**)	** (**)	x1	NA	Adv	375

\*Values as per standard weapon.

\*\*See rules for this equipment in the *Advanced Weapons And Equipment* section, starting on p. 274.

## ADVANCED AEROSPACE WEAPON CLASSES

Autocannon	
Inner Sphere	Clan
Standard ACs (All); Light ACs (All); Rotary ACs (All); Ultra ACs (All);	Ultra ACs (All); Gauss Rifles (Standard, HAG, and Rotary); Light Machine Gun;
Hyper-Velocity ACs (All); Gauss (Standard, Heavy, Improved Heavy,	Artillery Cannon (All)
Light, MagShot); Light Machine Gun; Rifle (All); Artillery Cannon (All)	

Lasers	
Inner Sphere	Clan
ER Lasers (All); Standard Lasers (Medium, Large); TAG; Blazer; Bombast	ER Lasers (All); Heavy Lasers (Small, Medium, Large)*; TAG; Improved Heavy Lasers
Laser*	(Small, Medium, Large)

LB-X Autocannon	
Inner Sphere	Clan
LB-X ACs (All); Gauss (Silver Bullet)	LB-X ACs (All)

Pulse Lasers	
Inner Sphere	Clan
Pulse Lasers (Medium, Large); Variable-Speed (All); X-Pulse (All)	Pulse Lasers (Small, Medium, Large); ER Pulse Lasers (Small, Medium, Large)*

Point Defense Weapons	
Inner Sphere	Clan
Anti-Missile System (Standard and Laser); Standard Laser (Small);	Anti-Missile System (Standard and Laser); Pulse Laser (Micro); Flamer (Standard and ER);
Pulse Laser (Small); Machine Gun (Standard and Heavy); Flamer (Standard and ER)	Machine Gun (Standard and Heavy); Gauss (AP)

PPCs	
Inner Sphere	Clan
PPCs; ER PPCs; Light PPCs; Heavy PPCs; Snub-Nose PPCs;	ER PPCs
PPC Capacitor**	

Plasma Weapons	
Inner Sphere	Clan
Plasma Rifle	Plasma Cannon

ATMs	
Inner Sphere	Clan
None	ATMs (All)

LRMs	
Inner Sphere	Clan
LRMs (All); LRMs + Artemis (All); NLRMs (All); ELRMs (All);	LRMs (All); LRMs + Artemis (All); Streak LRMs (All)
Thunderbolts (All)	

MMLs	
Inner Sphere	Clan
MMLs (All); MMLs + Artemis (All)	None

MRMs	
Inner Sphere	Clan
MRMs (All); MRMs + MRM FCS (All)	None

Rocket Launchers	
Inner Sphere	Clan
Rocket Launchers (All)	None

SRMs	
Inner Sphere	Clan
SRMs (All); SRMs + Artemis (All); Streak SRMs (All); Narc/iNarc Lauchner;	SRMs (All); SRMs + Artemis (All); Streak SRMs

Capital Missiles	
Inner Sphere	Clan
Killer Whales, White Sharks, and Barracudas (All); AR-10s (All);	Killer Whales, White Sharks, and Barracudas (Standard only); AR-10s (Standard only);

Kraken-T; Screen Launcher; Piranhas; Stingrays; Swordfishes; Manta Rays	Piranhas; Stingrays; Swordfishes; Manta Rays
---	--

Capital Lasers	
Inner Sphere	Clan
NL35; NL45; NL55; SCL/1; SCL/2; SCL/3	NL35; NL45; NL55

Capital PPCs	
Inner Sphere	Clan
N-PPCs (All)	N-PPCs (All)

Capital Autocannon	
Inner Sphere	Clan
NACs (All); SCCs (All); Mass Drivers (All)	NACs (All)

Capital Gauss	
Inner Sphere	Clan
N-Gauss (All)	N-Gauss (All)

Artillery	
Inner Sphere	Clan
Thumper; Sniper; Long Tom; Arrow IV; Cruise Missiles (All)	Thumper; Sniper; Long Tom; Arrow IV

\*Laser Weapon Bays that include these weapons suffer an additional to-hit modifier as follows: Bombast Lasers (+3); Heavy Lasers (but not Improved Heavy Lasers) +1; ER Pulse Lasers (-1). These modifiers replace the bay's standard attack modifier, using the highest modifier if multiple weapon types are present.

\*\*PPC Capacitors require one of the applicable PPC types

Weapon/Item	Tech Base	Tech Rating	Latest Intro Date (IS / Clan)	Cost (C-bills)	Ammo (per Ton)	WT (Tons)
Mine-Clearance LRMs	IS	C/X-X-E	3069 / NA	x4	x1	x1
Smoke SRMs	IS / Clan	C/D-D-D	2333 / 2333	x1.5	x1	x1
Smoke LRMs (IS)	IS / Clan	C/D-D-D	2333 / 2333X	x1.5	x1	x1
Smoke LRMs (Clan)	Clan	D/D-D-D	NA / 2825	x1.5	x1	x1
Swarm LRMs (IS)	IS / Clan	E/E-X-D	3053 / 2621X	x2	x1	x1
Swarm LRMs (Clan)	Clan	F/E-X-D	NA / 2825	x2	x1	x1
Swarm-I LRMs	IS	E/X-X-D	3057 / NA	x3	x1	x1
Tandem-Charge SRMs	IS	E/X-X-E	2757 / 2757X	x5	x0.5	x1
Tear Gas SRMs	IS	C/B-B-B	2375 / 2375	x2	x1	x1
Thunder LRMs (IS)	IS / Clan	E/D-X-D	3052 / 2620X	x2	x1	x1
Thunder LRMs (Clan)	Clan	F/D-X-D	NA / 2830	x2	x1	x1
Thunder-Active LRMs	IS	E/X-X-E	3058 / NA	x3	x1	x1
Thunder-Augmented LRMs	IS	E/X-X-E	3057 / NA	x4	x1	x1
Thunder-Inferno LRMs	IS	E/X-X-D	3056 / NA	x1	x1	x1
Thunder-Vibrobomb LRMs	IS	E/X-X-E	3057 / NA	x2.5	x1	x1
<b>'Mech Mortars</b>						
Airburst	IS / Clan	C/B-D-C	2544 / 2544	48,000	x1	x1
Anti-Personnel	IS / Clan	B/B-B-B	2531 / 2531	24,000	x1	x1
Armor Piercing (Shaped Charge)	IS / Clan	C/B-B-B	2531 / 2531	28,000	x1	x1
Flare	IS / Clan	B/A-A-A	2536 / 2536	14,000	x1	x1
Semi-Guided	IS	C/X-X-E	3064 / NA	60,000	x1	x1
Smoke	IS / Clan	B/A-A-A	2531 / 2531	12,000	x1	x1
Remote Sensors	IS / Clan	E/E-F-E	2590 / 2590	25,000	x1	x1

\*Values as per standard weapon

NOTE: Ammo costs are per ton unless otherwise specified. Ammo costs, shots per ton, and weight multipliers apply to the weapon's standard munition type.

\*\*See special rules for this equipment

†Bomb costs are per bomb, not per ton

## § USED BY (WEAPON) COLUMN ABBREVIATION TABLE

SAC: Standard Autocannon

LAC: Light Autocannon

AIV: Arrow IV Missile System

SAT: Standard Artillery (includes Sniper, Thumper, and Long Tom)

SAW: Sniper Artillery Weapon

TAW: Thumper Artillery Weapon

LAW: Long Tom Artillery Weapon

EO(#): External Ordnance Weapon (Number indicates how many bomb points occupied)

VFL: Vehicular Flamer

FLG: Fluid Gun

SPR: Sprayer

VGL: Vehicular Grenade Launcher

LMN: Land Mine

MMN: Sea (Maritime) Mine

SMN: Space Mine

SRM: Standard SRM Launchers

LRM: Standard LRM Launchers

MML: Multi-Missile Launchers

SSRM: Streak SRMs

NMB: Standard Narc Missile Beacon

MMR: 'Mech Mortar Launchers

## ADVANCED UNIT COSTS TABLES

### ADVANCED SUPPORT VEHICLE COSTS

$$\text{Base Unit Cost} = (\text{Chassis Cost} + \text{Engine Cost} + \text{Armor Cost} + \text{Weapons and Equipment Cost}) \times \text{OmniVehicle Multiplier} \times \text{Vehicle Type Multiplier}$$

Support Vehicle Base Structural Costs	
Chassis	2,500 x Chassis Cost Multiplier* x Chassis Weight (in tons)
Engine	5,000 x Engine Cost Multiplier** x Engine Weight (in tons)
Armor	Armor Points x Cost per Point†
Weapons and Equipment	See appropriate Equipment Cost Tables
OmniVehicle	x 1.25

\*Apply all Chassis Cost Multipliers that apply (see Chassis Cost Multipliers)

\*\*See Engine Cost Multipliers

†See Armor Costs (per Point)

Support Vehicle Type Multipliers		Chassis Cost Multipliers		Engine Cost Multipliers		Armor Costs	
Vehicle Type	Total Cost Multiplier	Chassis Modifier Type	Multiplier	Engine Type	Multiplier	Armor Type	Cost (per Point)
Large Airship	1 + (Vehicle Tonnage ÷ 10,000)	Amphibious	x1.25	Steam	x0.8	BAR 2	50
Satellite	1 + (Vehicle Tonnage ÷ 75)	Armored	x2	ICE	x1	BAR 3	100
Rail	1 + (Vehicle Tonnage ÷ 250)	Environmental Sealing	x1.75	External	x1	BAR 4	150
Large Naval Vessel	1 + (Vehicle Tonnage ÷ 100,000)	External Power Pickup	x1.1	Batteries	x1.2	BAR 5	200
		OmniVehicle	x1	Fuel Cell	x1.4	BAR 6	250
		Submersible	x3.5	Solar	x1.6	BAR 7	300
		Tractor	x1.1	MagLev	x2.5	BAR 8	400
		Trailer	x0.75	Fission	x3	BAR 9	500
		Ultra-Light*	x1.5	Fusion	x2	BAR 10	625

## BUILDING AND MOBILE STRUCTURE COSTS

$$\text{Base Unit Cost} = (\text{Structure Cost} + \text{Engine/Generator Cost} + \text{Motive System Cost} + \text{Armor Cost} + \text{Weapon and Equipment Cost}) \times (1 + \text{CF} \div 100)^*$$

\*In the case of structures using Capital-scale CF, multiply the CF value by 10 to find the "standard" CF

Structure Costs (per hex)	
Structure Type	Structure Cost (per Level)
Tent	1,000 x Structure Cost Multiplier x CF
Hangar	8,000 x Structure Cost Multiplier x CF
Standard Building	10,000 x Structure Cost Multiplier x CF
Gun Emplacement	20,000 x Structure Cost Multiplier x CF
Fortress	20,000 x Structure Cost Multiplier x CF
Castle Brian	100,000 x Structure Cost Multiplier x CF
Wall*	5,000 x Structure Cost Multiplier x CF
Fence*	800 x CF
Road/Pavement†	7,500
Bridge	12,000 x CF
Standard Rail†	7,000
MagLev Rail†	14,000

\*Wall and Fence costs are per hexside, rather than per hex

†These structures have a fixed Level of 1 for structure cost purposes

Engine/Generator Costs	
E/G Type	E/G Cost*
Steam	4,000
Internal Combustion	5,000
Fuel Cell	7,000
Solar	8,000
Fission	15,000
Fusion	10,000
External-Source	5,000

\*All Engine/Generator Costs are per ton of engine/generator (not including fuel)

Motive System Costs (Mobile Structures Only)	
Motive Type	Motive System Cost*
Ground	10,000 x CF x MP
Air	40,000 x CF x MP
Water (Surface)	20,000 x CF x MP
Water (Submersible)	35,000 x CF x MP

\*All Motive System Costs are per hex of Mobile Structure; non-mobile Structures receive a Motive System Cost of 0

Structure Armor	
Tech Base	Cost (C-bills)
Inner Sphere	10,000 x Armor Tonnage
Clan	15,000 x Armor Tonnage

Structure Cost Multipliers	
Structural Modifications	Final Cost Multiplier
Environmental Sealing	x1.5
Heavy-Metal Superstructure	x1.25
High/Low Ceilings	x1.1
Open-Space Construction	x2.5
Subsurface (Underwater or Underground)	x5
Tunnel	x1.875

Miscellaneous Structure Equipment Costs	
Item	Item Cost
Fuel Storage	100 x Total Storage Tonnage
Large Door	10,000 x Door Height (in Levels)
Industrial Elevators	15,000 x Total Elevator Tonnage
Unspecified Equipment	5,000 x CF (per Hex)
Weapon Automation	1,000 x Total Automated Weapon Tonnage*

\*Do not count ammunition, heat sinks, power amplifiers or turret mechanisms

## UNDERWATER RANGE TABLE (ADVANCED WEAPONS)

Weapon	Underwater Range
Binary Laser (Blazer) Cannon	0/3/6/9
Bombast Laser	0/3/6/9
Chemical Laser, Small	0/1/2/—
Chemical Laser, Medium	0/2/4/6
Chemical Laser, Large	0/3/6/9
ER Pulse Laser, Small	0/1/2/4
ER Pulse Laser, Medium	0/3/6/9
ER Pulse Laser, Large	0/4/10/16
Improved Heavy Laser, Small	0/1/2/—
Improved Heavy Laser, Medium	0/2/4/6
Improved Heavy Laser, Large	0/3/6/9
Variable-Speed Laser, Small	0/1/2/3
Variable-Speed Laser, Medium	0/1/3/6
Variable-Speed Laser, Large	0/2/5/9
X-Pulse Laser, Small	0/1/2/3
X-Pulse Laser, Medium	0/2/4/6
X-Pulse Laser, Large	0/3/6/9
Laser Anti-Missile System (IS)	*
Laser Anti-Missile System (Clan)	*
Naval (Capital) Lasers	**
Naval (Capital) PPCs	**
Sub-Capital Lasers	**

\*Laser Anti-Missile Systems used underwater affect torpedoes in the same manner as they do missiles

\*\*Capital-scale energy weapons suffer no range effects when fired while submerged, but do receive a +1 to-hit modifier for every 12 depths below the surface that they are fired from

## SKILLED EVADING

PAGE 19

Piloting Skill	To-Hit Modifier for Evading
6 or greater	+0
4-5	+1
2-3	+2
0-1	+3

## SHIELDING

PAGE 19

Unit Type	Modifier
Vehicle	+1
*Mech, ProtoMech or Mechanized Infantry*	+2
Large Vehicle**	+3

\*See below.

\*\*Combat or Support Vehicle. Rail and Large Naval Vessel Support Vehicles cannot use the Shielding movement mode.

## TAKING DAMAGE WEIGHT CLASS PSR MODIFIERS

PAGE 23

Weight Class	Modifier
Light (Ultra-Light)	+1
Medium	+0
Heavy	-1
Assault	-2

## PILOTING SKILL RATING MOF FALLING

PAGE 24

Piloting Skill Rating	Margin of Failure
6-7	0
2-5	1
0-1	2

## TURN MODE

PAGE 25

MP Expended	Turn Mode
1-4	0
5-9	1
10-14	2
15-19	3
Every 5 above 19	+1
Light Vehicle	-1
Medium/Heavy Vehicles	+0
Assault Vehicle	+1
Mud, Sleet, Heavy Fog or Heavy Rainfall	+1*†
Ice, Heavy Snowfall	+2*‡

\*Does not apply to Hover, VTOL or WiGE Vehicles.

†Does not apply to tracked vehicles

‡Only apply a +1 to tracked vehicles

## FIRE/SMOKE RESOLUTION SEQUENCE

PAGE 46

- Follow these steps, in order, during every End Phase:
1. Drift existing smoke clouds
  2. Check for dissipation of existing smoke clouds
  3. Check for spread of existing fires
  4. Place new smoke clouds from existing fires (including any new fires started)
  5. Check for weather conditions extinguishing existing fires (including any new fires started)

Terrain	Modifiers*
Planted Fields	-1
Woods	+0
Jungle	+1
Deep Snow	+2
Buildings	
Hangar	
Light	-2
Medium	-1

Terrain	Modifiers*
Hangers (Cont.)	
Heavy	+0
Hardened	+1
Standard/Wall	
Light	0
Medium	+1
Heavy	+2
Hardened	+3

Terrain	Modifiers*
Fortress	
Medium	+2
Heavy	+3
Hardened	+4
Castles Brian	
Heavy	+5
Hardened	+6

## FAILED MANEUVER

PAGE 26

2D6 Roll	Effect
2-7	<b>Minor fishtail.</b> The attempted turn fails, and the MP are expended for the attempt. The vehicle can continue moving normally; it cannot attempt to make the turn in that hex, however, and must enter another hex before making another turn attempt.
8-9	<b>Moderate fishtail.</b> The vehicle immediately makes an additional 1-hexside facing change (at no MP cost) in the same direction as the controlling player originally intended. Ground vehicles roll once on the Motive System Damage Table (see p. 193, TW), with a -1 modifier.
10-11	<b>Serious fishtail.</b> The vehicle immediately makes an additional 1-hexside facing change (at no MP cost) in the same direction as the controlling player originally intended. Ground vehicles roll once on the Motive System Damage Table (see p. 193, TW). The vehicle's movement ends immediately.
12-13	<b>Skid.</b> The turn fails completely, ending the vehicle's movement. Apply Skidding rules (see <i>Ground Vehicles</i> , p. 62, TW).
14+	<b>Major Skid.</b> The driver loses control of the vehicle. Wheeled vehicles begin to flip over, taking damage to their side armor and turret(s) (see <i>Flipping Over</i> , p. 26). Tracked vehicles, VTOLs and hovercraft do not flip over; for them, treat this result as a normal skid (see <i>Ground Vehicles</i> , p. 62, TW). Naval vessels and hydrofoils capsize and sink, and are effectively destroyed.

Vehicle Type	Modifiers	Vehicle Weight Class	Modifiers
Tracked, Naval	+0	Light	+1
Wheeled*, VTOL	+2	Medium	+0
Hovercraft, WiGE, Hydrofoil	+4	Heavy	-1
		Assault	-2

\*Apply a -2 modifier if the wheeled vehicle occupies a paved hex when it failed the Driving Skill Roll.

## SPREADING FIRES

PAGE 44

Situation	Success Number*
Crossing non-burning hex	+3
No Wind**	
Hex is downwind	9+
Hex is 60° from downwind	11+
Light and Moderate Gale	
Hex is downwind	7+
Hex is 60° from downwind	10+
Heavy Gale and Storm	
Hex is downwind	6+
Hex is 60° from downwind	9+

\*All modifiers are cumulative

\*\*For every 10 degrees above 30 degrees Celsius, apply a -1 modifier. For every 10 degrees below -30 degrees Celsius, apply a +1 modifier

†May not use small laser or ER small laser, or any kind of micro laser.

‡Includes missile infernos, inferno fuel ammo, inferno-IV artillery, inferno bombs, and incendiary grenades.

§May not use any type of Gauss rifle, SRM-2 or conventional SRM infantry.

¶Roll 1D6 to randomly determine the "down wind" direction each time.

§Except under the following conditions: in Vacuum and Trace Atmospheric Pressures and in Tornado F1-F3 and Tornado F4+, no fire is possible. For Castles Brian hexes, fire is not automatic; instead, divide the standard Heavy and Hardened modifiers in half (round down) and apply a +2 modifier when making the roll to start a fire.

## STARTING FIRES

Weapon Type	Success Number*
Flamer	4+
Incendiary LRMs	5+
Direct-Fire Energy or Pulse Weapon†	7+
Missile or Direct-Fire Ballistic†	9+
Plasma Weapon and Inferno††	Automatic§

## ADVANCED DETERMINING CRITICAL HITS PAGE 74

Damage Value Grouping	Modifier
1-5	+0
6-10	+1
11-15	+2
16-20	+3
21+	+4

2D6 Roll	Effect
2-8	No Critical Hit
9-10	Roll 1 Critical Hit Location
11-12	Roll 2 Critical Hit Locations
13-14	Roll 3 Critical Hit Locations
15+	Head/Limb Blown Off; Roll 3 Critical Hit Locations*

\*Only roll 3 critical hit locations if the attack strikes the torso

## MISSILE WEAPONS CRITICAL DAMAGE PAGE 76

2D6* Roll	Effect
2-3	Minor damage; no effect
4-5	Moderate damage; attacks with weapon add +1 to-hit modifier
6-7	Damage to ranging system; shots at medium and long range suffer an additional +1 to-hit modifier (as well as at extreme and LOS range, if those rules are in use; see p. 85)
8-9	Ammo feed damage; weapons that can fire various types of ammo may no longer switch between them, must fire last ammo type used. To-Hit Roll result of 2 for attacks with weapon causes an ammo explosion in the ammo bin that fed that shot (the controlling player decides which ammo slot explodes; if there is an ammo bin with shots remaining, the player must select that slot, meaning he cannot select an ammo slot that is empty if another slot of the same ammo type is not empty).
10-11	Weapon severely damaged (mark off another critical slot on the weapon, the topmost slot available); cannot fire
12+	Weapon destroyed (mark off all critical slots on the weapon)

\*Add number of critical slots damaged to this result

## COCKPIT CRITICAL DAMAGE PAGE 76

2D6 Roll	Effect
2-5	Minor Wound; apply one hit against MechWarrior
6-7	Moderate Wound; apply two hits against MechWarrior
8-9	Severe Wound; apply three hits against MechWarrior
10-11	Critical Wound; apply four hits against MechWarrior
12+	MechWarrior Killed/Cockpit destroyed (mark off slot)

## WEIGHT CLASS PHYSICAL ATTACK MODIFIERS

Weight Class	Modifier
Light (Ultra-Light)	-2
Medium	-1
Heavy/Assault	+0

## MAXIMUM ADDITIONAL BATTLE ARMOR PAGE 97

'Mech Weight Class	Total Number of Battle Armor	'Mech Weight Class	Total Number of Battle Armor
Light	2	Heavy	4
Medium	3	Assault	6

## DIRECT-FIRE ENERGY/PULSE WEAPONS CRITICAL DAMAGE PAGE 75

2D6* Roll	Effect
2-3	Minor damage; no effect
4-5	Moderate damage; attacks with weapon add +1 to-hit modifier
6-7	Focus misaligned; weapon inflicts -1 damage, additional +1 to-hit modifier applies to shots at medium and long range (as well as at extreme and LOS range, if those rules are in use; see p. 85).
8-9	Emitter damage; weapon generates +1 Heat Point. To-Hit Roll result of 2 for an attack with the weapon causes overload with effects identical to an ammo explosion, inflicting damage equal to the damage inflicted by the weapon; for Variable Damage weapons, use the Damage Value at short range.
10-11	Weapon severely damaged (mark off another critical slot on the weapon, the top most slot available); cannot fire
12+	Weapon destroyed (mark off all critical slots on the weapon)

\*Add number of critical slots damaged to this result

## DIRECT-FIRE BALLISTIC AND ARTILLERY WEAPONS CRITICAL DAMAGE PAGE 76

2D6* Roll	Effect
2-3	Minor damage; no effect
4-5	Moderate damage; attacks with weapon add +1 to-hit modifier
6-7	Barrel damage; To-Hit Roll result of 2 for attack with weapon causes it to jam
8-9	Ammo feed damage; weapons that can fire various types of ammo may no longer switch between them, must fire last ammo type used. To-Hit Roll result of 2 for attack with weapon causes an ammo explosion in an ammo bin that feeds that shot (the controlling player decides which ammo slot explodes; if there is an ammo bin with shots remaining, the player must select that slot, meaning he cannot select an ammo slot that is empty if another slot of the same ammo type is not empty).
10-11	Weapon severely damaged (mark off another critical slot on the weapon, the topmost slot available); cannot fire
12+	Weapon destroyed (mark off all critical slots on the weapon)

\*Add number of critical slots damaged to this result

## EQUIPMENT CRITICAL DAMAGE PAGE 76

2D6* Roll	Effect
2-7	Minor damage; no effect
8-9	Moderate damage; player must roll 7+ before each use for damaged item to work
10-11	Severe damage; player must roll 10+ before each use for damaged item to work
12+	Item destroyed

\*Add number of critical slots damaged to this result

## SUPPRESSING FIRE PAGE 87

Weapon Type	Modifier
Direct Fire (Ballistic or Energy), Cluster (Ballistic), Pulse	+0
Cluster (Missile)	+1
Burst Fire Weapon: 1D6 or 2D6	+2
Burst fire Weapon: 3D6 or 4D6+	+3
Area-Effect	+4
Additional Weapons Beyond First	+1

## WIND STRENGTH PAGE 47

1D6 Roll	Wind Strength*
1-2	No Wind
3	Light Gale**
4	Moderate Gale**
5	Strong Gale**
6	Storm**

\*Tornado F1-F3 and Tornado F4+ Weather Conditions are not on this table, as smoke does not exist under such conditions.

\*\*See *Weather Conditions* (p. 57) for additional game effects from such wind conditions.

## ADVANCED FOUR-LEGGED/PRONE 'MECH HIT LOCATION

PAGE 77

2D6 Rolls	Left Side	Front	Rear	Right Side
2*	Left Torso [critical]	Center Torso [critical]	Center Torso (R) [critical]	Right Torso [critical]
3	Left Leg	Right Leg	Right Arm	Right Leg
4	Left Rear Leg/Left Arm	Right Rear Leg/Right Arm	Right Front Leg/Right Leg	Right Rear Leg/Right Arm
5	Left Front Leg/Left Arm	Right Front Leg/Right Arm	Right Rear Leg/Right Leg	Right Front Leg/Right Arm
6	Left Front Leg/Left Leg	Right Front Leg/Right Torso	Right Rear Leg/Right Torso (R)	Right Front Leg/Right Leg
7	Left Rear Leg/Left Torso	Center Torso	Center Torso (R)	Right Rear Leg/Right Torso
8	Center Torso	Left Torso	Left Torso (R)	Center Torso
9	Right Torso	Left Arm	Left Leg	Left Torso
10	Right Arm	Left Front Leg/Left Arm	Left Rear Leg/Left Leg	Left Arm
11	Right Front Leg/Right Leg	Left Front Leg/Left Leg	Left Rear Leg/Left Arm	Left Front Leg/Left Leg
12	Right Rear Leg/Head	Left Rear Leg/Head	Left Front Leg/Head	Left Rear Leg/Head

\*A result of 2 may inflict a critical hit. Apply damage to the armor in that section in the normal manner, but the attacking player also rolls once on the Determining Critical Hits Table, p. 124, TW.

## HEAT SINK COOLANT FAILURE MODIFIER

PAGE 105

Heat Level	Modifier
5-10	+0
11-15	+1
16-20	+2
21-25	+3
26-30	+4
31-35	+5
36-40	+6
41-45	+7
46-50	+8

## PHYSICAL WEAPON ATTACKS ADDENDUM

PAGE 89

Weapon Type	To-Hit Modifier	Damage Value	To-Hit Location Table	Firing Arc**	Affected by TSM	To-Hit/Damage Value Affected by Actuator Damage
Chain Whip	-2	1/per 10 tons +1‡	Standard	Arm	No	Yes/No
Claws	+1	1/per 7 tons‡‡	Punch	Arm	Yes	Yes/Yes
Flail	+1	9	Standard	Arm	No	Yes/No
Lance	+1	1/per 5 tons††	Standard	Arm	Yes	Yes/Yes
Mace	+2	1/per 4 tons***	Standard*	Arm	Yes	Yes/Yes
Shields	†	†	Standard	Arm	No	Yes/No
Vibroblade						
Deactivated	-2	1/per 10 tons + 1‡	Standard*	Arm	Yes	Yes/Yes
Activated	-2	§	Standard*	Arm	No	Yes/No

\*Roll normally on the 'Mech Hit Location Table. Alternatively, when the controlling player announces the physical weapon attack, he may also announce that he will use the Punch or Kick Hit Location Table to resolve damage if the attack succeeds, in which case apply a +4 modifier in addition to all the standard modifiers, including the standard to-hit modifier for the weapon (this modifier does not apply when attacking on the Punch/Kick Location Table due to attacks from different levels; see p. 150, TW).

\*\*The target of the physical weapon attack can be in the 'Mech's forward arc or in the side arc corresponding to the arm in which the equipment is mounted.

\*\*\*A successful attack does 1 point of damage for every 4 tons that the attacking 'Mech weighs (round up).

†See *Shield*, p. 290

††A successful attack does 1 point of damage for every 5 tons that the attacking 'Mech weighs and may damage the internal structure of the target.

‡A successful attack does 1 point of damage for every 10 tons that the attacking 'Mech weighs (round up), + 1.

‡‡A successful attack does 1 point of damage for every 7 tons that the attacking 'Mech weighs (round up).

§See *Vibroblade*, p. 292

## ADVANCED 'MECH HIT LOCATION

PAGE 76

2D6 Rolls	Left Side	Front/Rear	Right Side
2*	Left Torso [critical]	Center Torso [critical]	Right Torso [critical]
3	Left Leg	Right Arm	Right Leg
4	Left Arm	Right Arm	Right Arm
5	Left Arm	Right Leg	Right Arm
6	Left Leg	Right Torso	Right Leg
7	Left Torso	Center Torso	Right Torso
8	Center Torso (R)	Left Torso	Center Torso (R)
9	Right Torso (R)	Left Leg	Left Torso (R)
10	Right Arm	Left Arm	Left Arm
11	Right Leg	Left Arm	Left Leg
12	Head	Head	Head

\*A result of 2 may inflict a critical hit. Apply damage to the armor in that section in the normal manner, but the attacking player also rolls once on the Determining Critical Hits Table, p. 124, TW.

## THROWING DISTANCE

PAGE 92

Percentage of Throwing 'Mech's Weight*	Total Distance
10%	1 Hex
7.5%	2 Hexes
5%	3 Hexes
2.5%	6 Hexes
1% (or less)	9 Hexes

\*If TSM is active, divide the weight of the thrown object/unit by 2 (rounding down) before consulting this table.

## 'MECH THROWING

PAGE 95

Unit Picking Up Is A:	Modifier	Unit Being Picked Up Is A:	Modifier
ProtoMech	+0	ProtoMech	+2
Light 'Mech	+0	'Mech	+0
Medium 'Mech:	+1		
Heavy 'Mech	+2		
Assault 'Mech:	+3		

## PPC FEEDBACK

PAGE 103

Target Distance	Avoid Feedback On
1 hex	10+
2 hexes	6+
3 or more hexes	3+

## OVERCHARGING PPC

PAGE 103

Weapon Type	Dice Rolled
Light PPC	1D6
PPC, ER PPC, Snub-nose	2D6
Heavy PPC	3D6

## AVOID SHUTDOWN PILOT SKILL RATING MODIFIERS

PAGE 104

Pilot Skill Rating	Modifier	Pilot Skill Rating	Modifier
6-7	+1	2-3	-1
4-5	+0	0-1	-2

## BUILDING CLASSIFICATION AND TYPE

Classification/Type	Construction Factor (CF)*	Max Armor (per hex)	Max Size (Hexes/Levels)	MP Cost Per Hex†	Piloting/Driving Skill Modifier	Damage Scaling: Damage to Building/Damage to Units‡
<i>Cost to Enter Any Hex</i> 1						
Tent	1–2	—	1/1	+0	—	x1/x0
Hangar		—				
Light	1–8		10/7	+0	+0†	x1/x0.5
Medium	9–16		14/10	+1	+0†	x1/x0.5
Heavy	17–45		18/13	+2	+1†	x1/x0.5
Hardened	46–75		20/14	+3	+3†	x1/x0.5
Standard§		—				
Light	1–15		6/5	+1	+0	x1/x1
Medium	16–40		8/8	+2	+1	x1/x1
Heavy	41–90		10/10	+3	+2	x1/x1
Fence	1	—	—/3	+1††	—	x1/x0
Wall		CF x 1				
Light	1–15		—/4	+1	+0	x1/x0.5
Medium	16–40		—/6	+2	+0	x1/x0.5
Heavy	41–90		—/8	+3	+1	x1/x0.5
Hardened	91–150		—/10	+4	+3	x1/x0.5
Bridge		—				
Light	1–15		—	NA‡‡	NA‡‡	x1/x1
Medium	16–40		—	NA‡‡	NA‡‡	x1/x1
Heavy	41–90		—	NA‡‡	NA‡‡	x1/x1
Hardened	91–150		—	NA‡‡	NA‡‡	x1/x1
Rail	151–650		—	NA‡‡	NA‡‡	x1/x1
Gun Emplacement		CF x 1				
Light	1–15		1/1	NA	NA	x0.5/x2
Medium	16–40		1/1	NA	NA	x0.5/x2
Heavy	41–90		1/1	NA	NA	x0.5/x2
Hardened	91–150		1/1	NA	NA	x0.5/x2
Fortress		CF x 1				
Medium	16–40		12/15	+3	+2	x0.5/x2
Heavy	41–90		15/20	+4	+3	x0.5/x2
Hardened	91–150		20/30	+5	+4	x0.5/x2
Castles Brian§§		CF x 2**				
Heavy	35–90		20/10	+4	+4	Capital/Capital**
Hardened	91–150		30/15	+5	+5	Capital/Capital**

\*See pp. 166-167, *TW*. The listed CFs show the range applicable to each building type. If a scenario does not specify a building's CF, assume that all its hexes have the maximum CF possible for that building type and classification.

†Infantry (except mechanized infantry) pay only 1 MP to enter a building hex regardless of building type; ProtoMechs and mechanized infantry pay only 2 MP to enter any building hex except for tents and fences (which cost only 1 MP). Hangars apply MP and Piloting Skill modifiers only when entering from outside, unless other factors apply (see *Hangars*, p. 116).

‡Round all damage down; if the damage is reduced to 0 or less, no damage is applied.

§As detailed in *TW*, except there is no Hardened type.

††Only applies to conventional infantry using Ground MP.

‡‡Units move over bridges (never through them) as though traveling on a road.

§§Area-effect weapons do not double their damage against Castles Brian hexes.

\*\*Castles Brian use capital-scale damage, as noted under *Scale* (see p. 238, *TW*). See *Scaled Damage* (p. 126) for more information.

### ARTILLERY RANGES

Type	Maximum Range (in mapsheets)	Type	Maximum Range (in mapsheets)
Arrow IV Missile (IS)	8	Cruise Missile/50	50
Arrow IV Missile (Clan)	9	Cruise Missile/70	90
Thumper	21	Cruise Missile/90	120
Sniper	18	Cruise Missile/120	150
Long Tom	30		

### INDIRECT ARTILLERY FLIGHT TIMES

Distance from Battlefield (in mapsheets)	Artillery† Flight Time (in turns)
Less than 1*	0
1–8	1
9–15	2
16–21	3
22–26	4
27–30	5
Cruise Missile‡ Flight Time (in turns)	
1 + (Number of mapsheets ÷ 5, round down)	

\*See *Direct-Fire Artillery*, p. 185.

†Arrow IV, Thumper, Sniper and Long Tom

‡Cruise Missile/50, Cruise Missile/70, Cruise Missile/90 and Cruise Missile/120

## ADVANCED BUILDING MOVEMENT

PAGE 120

Building Features	MP Cost/Hex*	Piloting Modifier**	Notes
Empty Hangar/Tunnel/Open-Space Hex	1	NA	Treat as Paved Terrain†
Hangar/Tunnel/Empty Cargo Hex	-1	-3	To a Minimum MP cost per hex of 1††
Non-Liquid Cargo Hex	+0	-2	
Liquid Cargo Hex	+1	+2	See <i>Liquid Fuel/Chemical Storage Tanks</i> (p. 134)
High Ceilings	+0	-1	Half all damage from movement (round down)‡
Low Ceilings	+1	+1	Double all damage from movement (round up)‡
Unspecified Equipment Hex‡‡	+0	+0	+1 to-hit modifier for weapon attacks (per hex)
Specified Equipment Hex‡‡	+1	+1	+2 to-hit modifier for weapon attacks (per hex)
Generator/Weapon Hex‡‡	+2	+2	+2 to-hit modifier for weapon attacks (per hex)
Heavy Metal Superstructure	+1	+2	Double damage to unit from failed Piloting Skill

\*In addition to all other applicable MP costs for the building type (see *Building Classification and Type Table*, p. 115)

\*\*In addition to all other applicable modifiers for the building type (see *Building Classification and Type Table*, p. 115)

†See *Open-Space Construction*, p. 138. Hangars and tunnels apply these rules only if they are as high as or taller than the moving unit, feature no equipment, and the unit is not moving through the building's outer walls (otherwise, apply the standard hangar MP and Piloting modifiers).

††Hangars and tunnels apply these costs and modifiers only if they are as high as or taller than the moving unit and feature interior equipment of any kind. (Do not apply normal hangar MP and Piloting costs if already inside.)

‡Applies to damage done both to the building and to the unit moving through it.

‡‡Do not count turreted or rooftop-based equipment.

## ADVANCED BUILDING CRITICAL HITS

PAGE 121

2D6 Roll	Effect
2-5	No Critical Hit
6	Weapon Malfunction
7	Gunners Stunned
8	Weapon Destroyed
9	Gunners Killed
10	Turret Jammed/Turret Locked*
11	Ammunition
12	Other

\*When rolling these critical hit results, roll 1D6. On a result of 1-3, the effect to the left of the slash occurs; on a 4-6 result, the effect to the right of the slash occurs.

## ARTILLERY ORDNANCE

PAGE 184

Ordnance Type	Damage Type	Weapon Type Damage Values (Radius)				
		Long Tom	Sniper	Thumper	Arrow IV	Cruise Missile
Air-Defense Arrow (ADA)*	F	—	—	—	20	—
Arrow IV Homing Missile*	AE	—	—	—	20	—
Arrow IV Non-Homing Missile*	AE, F	—	—	—	20/10 (R1)	—
Cluster*	AE, F	20/10 (R1)	15/5 (R1)	10/1 (R1)	20/10 (R1)	—
Copperhead*	AE	15 (R0)	10 (R0)	5 (R0)	—	—
Flechette*	AE, AI	*	*	*	—	—
High-Explosive (standard)	AE, F	25/15/5 (R2)	20/10 (R1)	15/5 (R1)	—	—
Minefield Rounds						
Thunder Active-IV*	AE	—	—	—	20 (R0)	—
Thunder FASCAM (Inner Sphere)*	AE	25 (R0)	20 (R0)	—	20 (R0)	—
Thunder FASCAM (Clan)*	AE	25 (R0)	20 (R0)	15 (R0)	30 (R0)	—
Thunder Vibrabomb-IV*	AE	—	—	—	20 (R0)	—
Non-Explosive Rounds**						
Illumination*	—	(Radius 3)	(Radius 2)	(Radius 1)	(Radius 4)	—
Inferno IV-Missiles*	AE, H, AI	—	—	—	(Radius 1)	—
Laser-Inhibiting Arrow Missile*	—	—	—	—	(Radius 0)	—
Smoke*	—	(Radius 1)	(Radius 1)	(Radius 1)	(Radius 1)	—
Cruise Missiles						
Cruise Missile/50	AE	—	—	—	—	50/25 (R1)
Cruise Missile/70	AE	—	—	—	—	70/45/20 (R2)
Cruise Missile/90	AE	—	—	—	—	90/65/40/15 (R3)
Cruise Missile/120	AE	—	—	—	—	120/95/70/45/20 (R4)

\*See additional rules for the specific ordnance in the *Advanced Weapons and Equipment* section.

\*\*The effect radius describes the area affected by a non-explosive shell. For example, an illumination round fired by a Long Tom has an effect radius of 3, so it affects the target hex, as well as any unit within 3 hexes of the target hex. Ordnance with an effect radius of 0 affects only the target hex.

## MINEFIELD DENSITY

PAGE 208

Minefield Density*	Target Number
5- or 10-point	9+
15- or 20-point	8+
25- or 30-point	7+

\*The EMP mine (see p. 365) cannot be weapon-delivered.

## ARTILLERY MODIFIERS

PAGE 180

Condition	Modifier
For every 2 points of Gunnery Skill less than 4 possessed by the spotting unit*	-1
For every 2 points of Gunnery Skill greater than 4 possessed by the spotting unit*	+1
Adjusting fire: for each previous shot fired at the target hex by the artillery unit*	-1

\*See *Artillery Spotters*, p. 181; Round any fractions down.

## ADVANCED BATTLE ARMOR WEIGHTS

PAGE 187

Weight Class	Tons of Cargo Space Occupied	Battle Armor Units (total occupied cargo space)		
		4 troopers	5 troopers	6 troopers
PA(L)/Exoskeleton	.25 tons	1 ton	1.25 tons	1.5 tons
Light	.5 tons	2 tons	2.5 tons	3 tons
Medium	1 ton	4 tons	5 tons	6 tons
Heavy	1.5 tons	6 tons	7.5 tons	9 tons
Assault	2 tons	8 tons	10 tons	12 tons

## EJECTION MODIFIERS

PAGE 197

Landing Terrain	Modifier
Clear	-2
Water	-1
Snow	-1
Deep Snow	-2
Rough	0
Rubble	0
Light Jungle/Woods/Ultra Rough	+2
Heavy Jungle/Woods/Ultra Rubble	+3
Ultra Jungle/Woods	+4
Per Level of Building	+1

Planetary Conditions	Modifier
Zero-G	+3
Low-G (more than .2 off Terran standard)	+2
High-G (more than .2 off Terran standard)	+3
Vacuum or Tainted Atmosphere*	+3
Trace or Very High Pressure Atmosphere	+2
Heavy Snow Fall/Ice Storm/Lightning Storm/Strong Gale/Torrential Downpour	+2
Blizzard/Storm/Tornado	+3

Situation	Modifier
BattleMech Prone	+5
Pilot Unconscious	+3
Per Point of Head Internal Structure Damage	+1
Automatic Ejection	+1

\*Assumes the pilot is wearing a suit to protect against vacuum or a tainted atmosphere; the pilot is killed immediately if in vacuum with no protection (see p. 56 for rules governing a tainted atmosphere and no protection).

## MORALE

PAGE 212

Experience Level	BattleMechs Morale Target	Combat Vehicles Morale Target	Infantry Morale Target	Support Vehicles Morale Target
Green	4	6	9	10
Regular	2	4	6	7
Veteran	—\$\$	2	4	5
Elite	—\$\$	—\$\$	2	2

\*Includes ProtoMechs and aerospace fighters.

†Includes military conventional fighters, Small Craft, DropShips and WarShips.

‡Includes military Support Vehicles, JumpShips and Space Stations.

§Includes IndustrialMechs (unless piloted by a military MechWarrior, in which case treat as a Combat Vehicle) and all civilian aerospace units.

\$\$See *Infernos* and *Cruise Missile Attack* (see p. 211).

Special Source Modifier (All)	Target Modifier
Inferno	+1/+3*
Cruise Missile	+2

\*The modifier to the left of the slash is for all non-infantry units, the modifier to the right of the slash for infantry.

Attack Source Modifier (Infantry Only)	Target Modifier
BattleMech in LOS	+1
Artillery	+2
Flamer or Fire	+3
Elite	—\$\$

Other Modifiers Modifier (Infantry Only)	Target Modifier
Broken Morale	+1
<i>Cumulative Modifiers</i>	
Light or Medium Battle Armor Unit	-1
Heavy or Assault Battle Armor Unit	-2
Anti-Mech Skill of 5 or less	-1
Conventional Infantry with Armor (see p. 317)	-1
Unit in Building	-2
Unit Dug In	-2

## BATTLEFIELD WRECKAGE

PAGE 187

**Tonnage:** In all instances, a unit must be 40 tons or greater to modify terrain upon destruction.

Unit Type	Terrain Type
'Mech	Rough
ProtoMech/Infantry	—
Combat Vehicles	Rough
Medium Support Vehicles	Rough
Large Support Vehicles/ Super-Heavy Vehicles	Ultra Rough
Rail	Ultra Rough
Fighters/Small Craft	Rough
DropShips/Mobile Structure	Ultra Rubble

## TRANSPORT BAYS STATUS

PAGE 218

1D6 Roll	Status	Turns To Activation**
1-2	Shutdown	4
3-4	Stand By/Empty	3
5	Stand By/Occupied	2
6	Operational*	1

\*Conventional Infantry are always considered "operational."

\*\*This is in ground turns; if using space turns, all units are considered "activated" after a single space turn, regardless of the units' status or the availability of technicians (though the lack of a technician still applies the +2 modifier to the Piloting Skill Roll to determine if a shut-down unit activated properly [see *Bay Personnel*, p. 202]).

## FATIGUE

PAGE 198

Piloting Skill Rating	Turn When Modifier Starts
6-7	Starting on Turn 10
4-5	Starting on Turn 14
2-3	Starting on Turn 17
0-1	Starting on Turn 20

## RECOVERING NERVE

PAGE 213

**NOTE:** These modifiers only apply if a friendly unit/commander is within seventeen hexes of the unit attempting to recover its nerve.

Commanders*	Target Modifier
Sub-force Commander in LOS	-1
Force Commander in LOS	-2

Infantry Only	Target Modifier
Friendly non-'Mech, non-infantry unit in LOS	-1
Friendly 'Mech in LOS	-2
Another Routed Infantry Unit in LOS	+1
Another Routed Non-Infantry Unit in LOS	+2
Routed Unit	+3

\*Only applies if Commanders (see p. 191) are in use.